

# VCCI Test Report

Product Name : Network Camera  
Model No. : IB9387-EH, IB9387-H

Applicant : VIVOTEK INC.

Address : 6F, No.192, Lien-Cheng Rd., Chung-Ho , New Taipei City,  
235, Taiwan, R.O.C.

Date of Receipt : 2018/10/24  
Issued Date : 2018/11/14  
Report No. : 18A0322R-ITJPP01V00  
Report Version : V1.0



The test results relate only to the samples tested.

The test results shown in the test report are traceable to the national/international standard through the calibration of the equipment and evaluated measurement uncertainty herein.

This report must not be used to claim product endorsement by TAF or any agency of the government.

The test report shall not be reproduced without the written approval of DEKRA Testing and Certification Co., Ltd.

# Test Report

Issued Date : 2018/11/14

Report No. : 18A0322R-ITJPP01V00

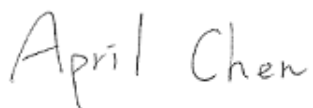

Product Name : Network Camera  
Applicant : VIVOTEK INC.  
Address : 6F, No.192, Lien-Cheng Rd., Chung-Ho , New Taipei City, 235,  
Taiwan, R.O.C.  
Manufacturer : VIVOTEK INC.  
Model No. : IB9387-EH, IB9387-H  
EUT Rated Voltage : DC 12V, By PoE  
EUT Test Voltage : AC 100V / 50Hz, By PoE  
Trade Name : VIVOTEK  
Applicable Standard : VCCI CISPR 32: 2016-11, Class A  
Test Result : Complied  
Performed Location : DEKRA Testing and Certification Co., Ltd.  
Linkou Laboratory  
No. 5-22, Ruishukeng  
Linkou District, New Taipei City, 24451, Taiwan  
TEL:+866-2-8601-3788 / FAX:+886-2-8601-3789

Documented By :   
\_\_\_\_\_  
(Senior Adm. Specialist / April Chen)

Reviewed By :   
\_\_\_\_\_  
( Engineer / Chifan Chen )

Approved By :   
\_\_\_\_\_  
( Director / Vincent Lin )

## Laboratory Information

We, **DEKRA Testing and Certification Co., Ltd.**, are an independent EMC and safety consultancy that was established the whole facility in our laboratories. The test facility has been accredited/accepted (audited or listed) by the following related bodies in compliance with ISO 17025, EN 45001 and specified testing scopes:

|                      |          |                       |
|----------------------|----------|-----------------------|
| <b>Taiwan R.O.C.</b> | <b>:</b> | <b>BSMI, NCC, TAF</b> |
| <b>Norway</b>        | <b>:</b> | <b>DNV</b>            |
| <b>USA</b>           | <b>:</b> | <b>FCC</b>            |
| <b>Japan</b>         | <b>:</b> | <b>VCCI</b>           |

The related certificate for our laboratories about the test site and management system can be downloaded from DEKRA Testing and Certification Co., Ltd. Web Site :

<http://www.dekra.com.tw/english/about/certificates.aspx?bval=5>

The address and introduction of DEKRA Testing and Certification Co., Ltd. laboratories can be founded in our Web site : [http://www.dekra.com.tw/index\\_en.aspx](http://www.dekra.com.tw/index_en.aspx)

If you have any comments, Please don't hesitate to contact us. Our contact information is as below:

### **Hsin Chu Laboratory:**

No.75-2, 3rd Lin, WangYe Keng, Yonghxing Tsuen, Qionglin Shiang, Hsinchu County 307, Taiwan (R.O.C.)

No.372, Sec. 4, Zhongxing Rd., Zhudong Township, Hsinchu County 310, Taiwan

No.372-2, Sec. 4, Zhongxing Rd., Zhudong Township, Hsinchu County 310, Taiwan

TEL:+886-3-592-8858 / FAX:+886-3-592-8859

TEL:+886-3-582-8001 / FAX:+886-3-5828-958 E-Mail : [info.tw@dekra.com](mailto:info.tw@dekra.com)

### **Lin Kou Laboratory**

No. 5-22, Ruishukeng, Linkou Dist., New Taipei City 24451, Taiwan (R.O.C.)

TEL : +886-2-8601-3788 / FAX : +886-2-8601-3789 E-Mail : [info.tw@dekra.com](mailto:info.tw@dekra.com)

### **Suzhou (China) Testing Laboratory :**

No.99 Hongye Rd., Suzhou Industrial Park, Suzhou,215006, Jiangsu,China

TEL : +86-512-6251-5088 / FAX : +86-512-6251-5098 E-Mail : [info.tw@dekra.com](mailto:info.tw@dekra.com)

## TABLE OF CONTENTS

| Description   | Page |
|---|------|
| 1. General Information .....                          | 5    |
| 1.1. EUT Description.....                             | 5    |
| 1.2. Mode of Operation .....                          | 6    |
| 1.3. Tested System Details .....                      | 7    |
| 1.4. Configuration of Tested System .....             | 8    |
| 1.5. EUT Exercise Software.....                       | 10   |
| 2. Technical Test .....                               | 11   |
| 2.1. Summary of Test Result.....                      | 11   |
| 2.2. List of Test Equipment .....                     | 12   |
| 2.3. Measurement Uncertainty.....                     | 13   |
| 2.4. Test Environment.....                            | 14   |
| 3. Conducted Emission .....                           | 15   |
| 3.1. Test Specification .....                         | 15   |
| 3.2. Test Setup.....                                  | 15   |
| 3.3. Limit.....                                       | 15   |
| 3.4. Test Procedure .....                             | 16   |
| 3.5. Deviation from Test Standard.....                | 16   |
| 3.6. Test Result.....                                 | 17   |
| 3.7. Test Photograph .....                            | 23   |
| 4. Conducted Emissions (Telecommunication Ports)..... | 25   |
| 4.1. Test Specification .....                         | 25   |
| 4.2. Test Setup.....                                  | 25   |
| 4.3. Limit.....                                       | 26   |
| 4.4. Test Procedure .....                             | 27   |
| 4.5. Deviation from Test Standard.....                | 27   |
| 4.6. Test Result.....                                 | 28   |
| 4.7. Test Photograph .....                            | 40   |
| 5. Radiated Emission.....                             | 43   |
| 5.1. Test Specification .....                         | 43   |
| 5.2. Test Setup.....                                  | 43   |
| 5.3. Limit.....                                       | 44   |
| 5.4. Test Procedure .....                             | 45   |
| 5.5. Deviation from Test Standard.....                | 45   |
| 5.6. Test Result.....                                 | 46   |
| 5.7. Test Photograph .....                            | 54   |
| 6. Attachment.....                                    | 57   |
| EUT Photograph.....                                   | 57   |

## 1. General Information

### 1.1. EUT Description

|              |                     |
|--------------|---------------------|
| Product Name | Network Camera      |
| Trade Name   | VIVOTEK             |
| Model No.    | IB9387-EH, IB9387-H |

Note: The EUT is including series models for different is marketing requirement.

## 1.2. Mode of Operation

DEKRA has verified the construction and function in typical operation. All the test modes were carried out with the EUT in normal operation, which was shown in this test report and defined as:

|                         |   |
|-------------------------|---|
| Pre-Test Mode           |   |
| Mode 1: IB9387-EH , DC  |   |
| Mode 2: IB9387-EH , PoE |   |
| Mode 3: IB9387-H , DC   |   |
| Mode 4: IB9387-H , PoE  |   |
| Final Test Mode         |   |
| Emission                | Mode 1: IB9387-EH , DC<br>Mode 2: IB9387-EH , PoE |

Note: According to pre-test data, we choose the worst case mode 1, 2 as the final and full testing.

### 1.3. Tested System Details

The types for all equipments, plus descriptions of all cables used in the tested system (including inserted cards) are:

| Test Mode |                       | Mode 1       |           |            |                    |
|-----------|-----------------------|--------------|-----------|------------|--------------------|
| Product   |                       | Manufacturer | Model No. | Serial No. | Power Cord         |
| 1         | Notebook PC           | DELL         | E5530     | 24QPXW1    | Non-shielded, 0.8m |
| 2         | Microphone & Earphone | RONEVER      | MOE240    | N/A        | N/A                |

| Test Mode |                       | Mode 2       |           |            |                    |
|-----------|-----------------------|--------------|-----------|------------|--------------------|
| Product   |                       | Manufacturer | Model No. | Serial No. | Power Cord         |
| 1         | Notebook PC           | DELL         | E5530     | 24QPXW1    | Non-shielded, 0.8m |
| 2         | Microphone & Earphone | RONEVER      | MOE240    | N/A        | N/A                |
| 3         | PoE                   | N/A          | N/A       | N/A        | Non-shielded, 1.8m |

### 1.4. Configuration of Tested System

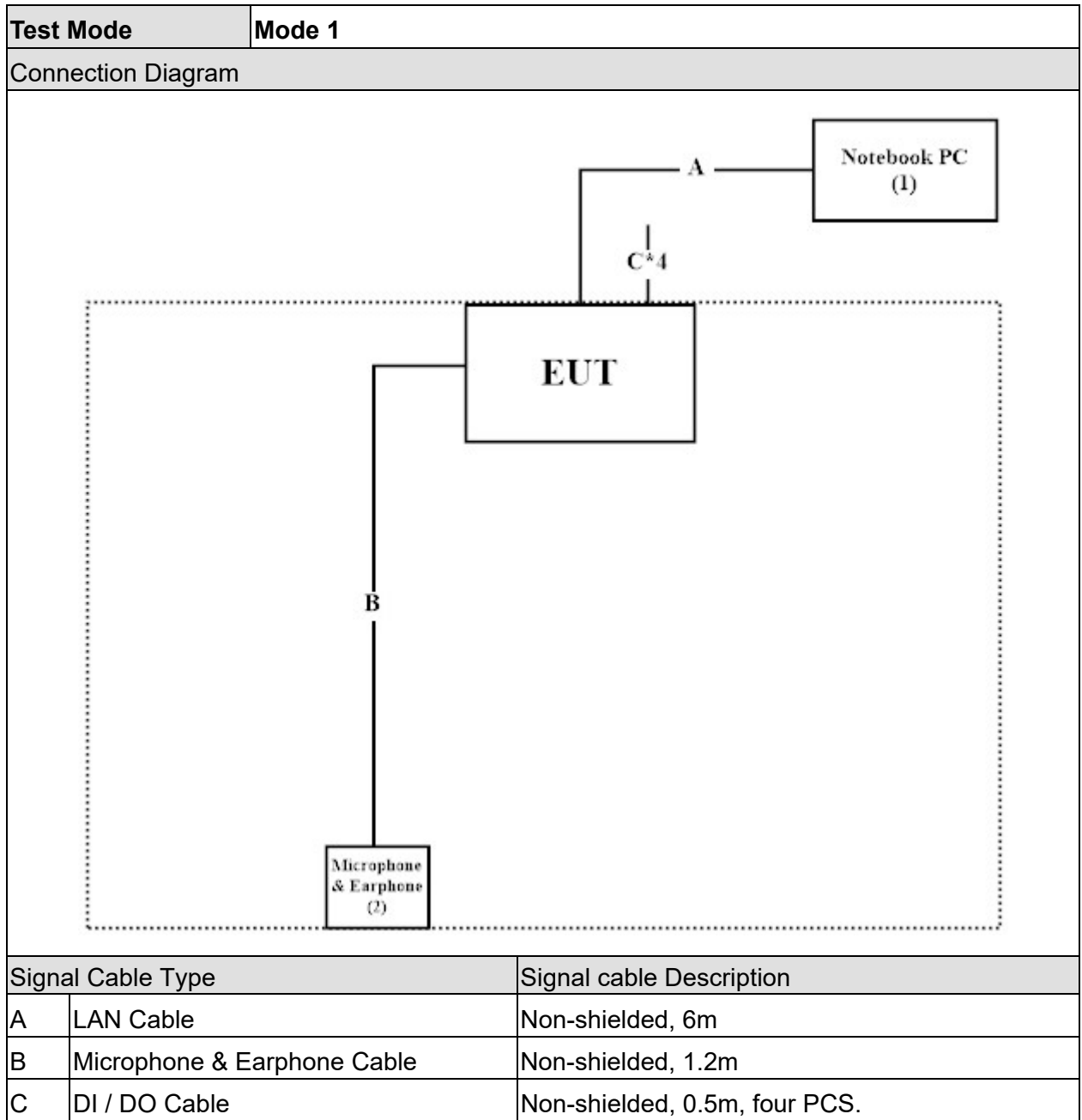

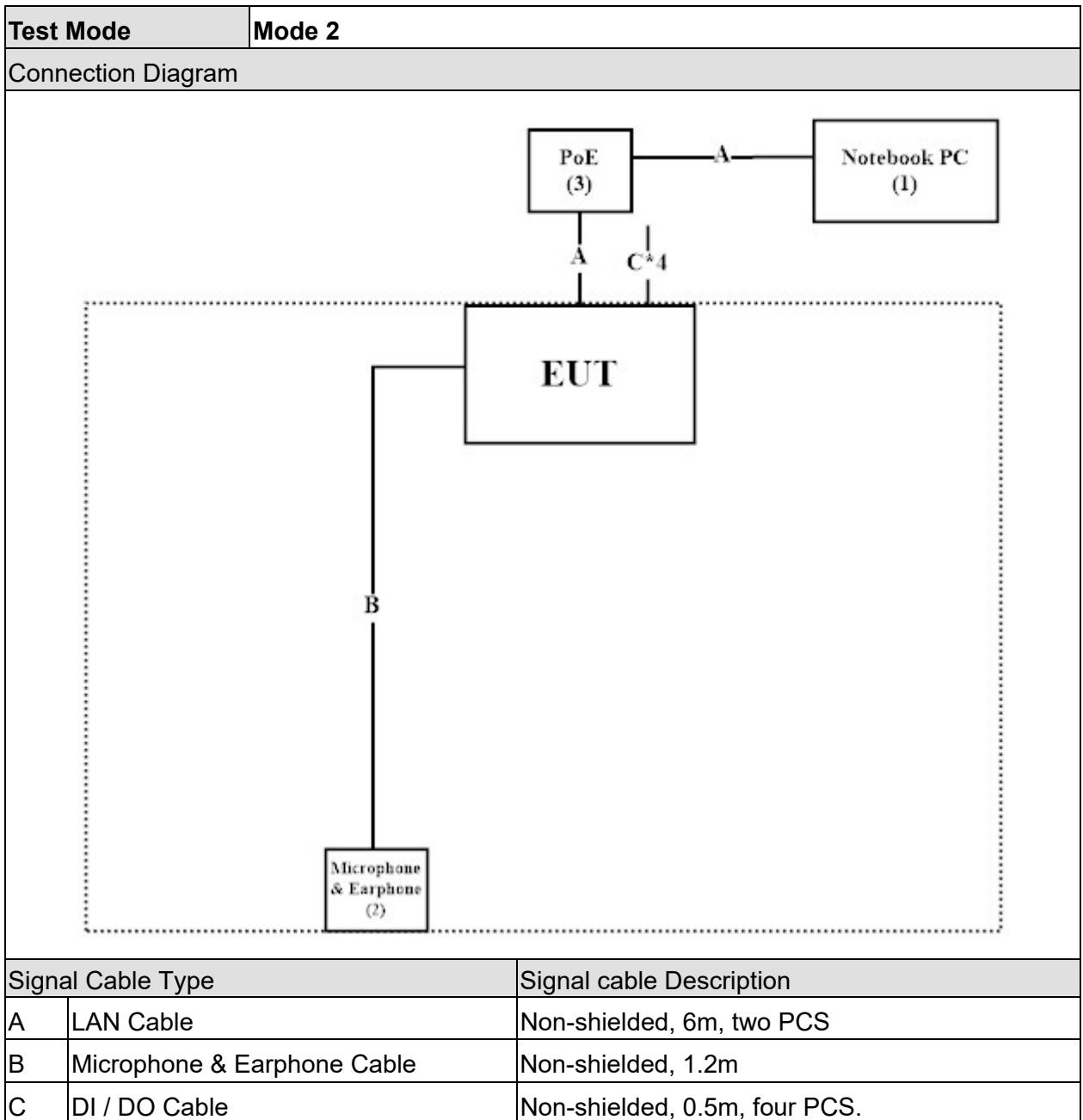

### 1.5. EUT Exercise Software

|   |  |
|---|--|
| 1 | Setup the EUT and simulators as shown on 1.4.                                      |
| 2 | Turn on the power of all equipment.  |
| 3 | The EUT will start to operate and display the video figure from the signal source. |
| 4 | The EUT will display "video figure" on monitor.                                    |
| 5 | SD card works while the EUT is recording.  |
| 6 | Repeat the above procedure (3) to (5).   |

## 2. Technical Test

### 2.1. Summary of Test Result

- No deviations from the test standards  
 Deviations from the test standards as below description:

| Emission                        |                                |                |           |
|---------------------------------|--------------------------------|----------------|-----------|
| Performed Item                  | Normative References           | Test Performed | Deviation |
| Conducted Emission              | VCCI CISPR 32: 2016-11 Class A | Yes            | No        |
| Impedance Stabilization Network | VCCI CISPR 32: 2016-11 Class A | Yes            | No        |
| Radiated Emission               | VCCI CISPR 32: 2016-11 Class A | Yes            | No        |

## 2.2. List of Test Equipment

### Conducted Emission / SR1

| Instrument        | Manufacturer | Type No. | Serial No  | Cal. Date  |
|-------------------|--------------|----------|------------|------------|
| EMI Test Receiver | R&S          | ESCS 30  | 100367     | 2018/01/23 |
| LISN              | R&S          | ENV216   | 100085     | 2018/03/09 |
| LISN              | R&S          | ESH2-Z5  | 836679/023 | 2018/08/06 |
| Coaxial Cable     | DEKRA        | RG 400   | LC016-RG   | 2018/06/21 |

### Impedance Stabilization Network / SR1

| Instrument                  | Manufacturer | Type No.        | Serial No  | Cal. Date  |
|-----------------------------|--------------|-----------------|------------|------------|
| EMI Test Receiver           | R&S          | ESCS 30         | 100367     | 2018/01/23 |
| LISN                        | R&S          | ENV216          | 100085     | 2018/03/09 |
| LISN                        | R&S          | ESH2-Z5         | 836679/023 | 2018/08/06 |
| Coaxial Cable               | DEKRA        | RG 400          | LC016-RG   | 2018/06/21 |
| Capacitive Voltage Probe    | Schaffner    | CVP2200A        | 18331      | 2017/11/17 |
| RF Current Probe            | FCC          | F-65            | 198        | 2017/11/21 |
| BALANCED TELECOM ISN        | FCC          | FCC-TLISN-T2-02 | 20316      | 2018/09/14 |
| Coupling Decoupling Network | Teseq        | CDN T800        | 30303      | 2018/05/16 |
| Coupling Decoupling Network | Teseq        | CDN ST08A       | 33998      | 2018/10/26 |
| Coupling Decoupling Network | Teseq        | CDN T8-Cat6     | 29669      | 2018/10/26 |

### Radiated Emission / Site 7

| Instrument        | Manufacturer | Type No.  | Serial No   | Cal. Date  |
|-------------------|--------------|-----------|-------------|------------|
| Broadband Antenna | Schwarzbeck  | VULB 9168 | 0853        | 2018/04/11 |
| EMI Test Receiver | R&S          | ESCI      | 100649      | 2018/07/20 |
| Coaxial Cable     | DEKRA        | RG 214    | LC007-RG    | 2018/06/18 |
| Pre-Amplifier     | DEKRA        | AP/0100A  | CHM/1009094 | 2018/06/18 |
| Site7 NSA         | DEKRA        | N/A       | N/A         | 2018/06/18 |

### Radiated Emission / CB7

| Instrument        | Manufacturer | Type No.    | Serial No | Cal. Date  |
|-------------------|--------------|-------------|-----------|------------|
| EMI Test Receiver | R&S          | ESU26       | 100433    | 2018/11/02 |
| Horn Antenna      | ETS-Lindgren | 3117        | 00202723  | 2018/08/08 |
| Horn Antenna      | SCHWARZBECK  | 9120D       | 576       | 2017/12/07 |
| Pre-Amplifier     | EMCI         | EMC051845SE | 980359    | 2018/10/12 |
| CB7 VSWR          | DEKRA        | N/A         | N/A       | 2018/06/25 |

### VCCI Test Site:

| Test Item                                   | Test Site          | VCCI No. |
|---|--------------------|----------|
| Conducted Emission                          | SR1                | C-2428   |
| Conducted Emission (Telecommunication Port) | SR1                | T-1473   |
| Radiated Emission                           | Site 7             | R-3748   |
| Radiated Emission                           | CB7                | R-3107   |
| Radiated Emission (Above 1GHz)              | CB7(9x6x6_Chamber) | G-35     |

### **2.3. Measurement Uncertainty**

#### Conducted Emission

The measurement uncertainty is evaluated as  $\pm 3.44$  dB.

#### Impedance Stabilization Network

The measurement uncertainty is evaluated as  $\pm 3.88$  dB.

#### Radiated Emission(Under 1GHz)

The measurement uncertainty is evaluated as  $\pm 4.22$  dB.

#### Radiated Emission(Above 1GHz)

The measurement uncertainty is evaluated as  $\pm 5.08$  dB.

## 2.4. Test Environment

| Performed Item                  | Items                      | Required | Actual   |
|---------------------------------|----------------------------|----------|----------|
| Conducted Emission              | Temperature (°C)           | 15-35    | 27       |
|                                 | Humidity (%RH)             | 25-75    | 57       |
|                                 | Barometric pressure (mbar) | 860-1060 | 950-1000 |
| Impedance Stabilization Network | Temperature (°C)           | 15-35    | 27       |
|                                 | Humidity (%RH)             | 25-75    | 57       |
|                                 | Barometric pressure (mbar) | 860-1060 | 950-1000 |
| Radiated Emission               | Temperature (°C)           | 15-35    | 25.9     |
|                                 | Humidity (%RH)             | 25-75    | 59       |
|                                 | Barometric pressure (mbar) | 860-1060 | 950-1000 |

### 3. Conducted Emission

#### 3.1. Test Specification

According to EMC Standard: VCCI CISPR 32

#### 3.2. Test Setup

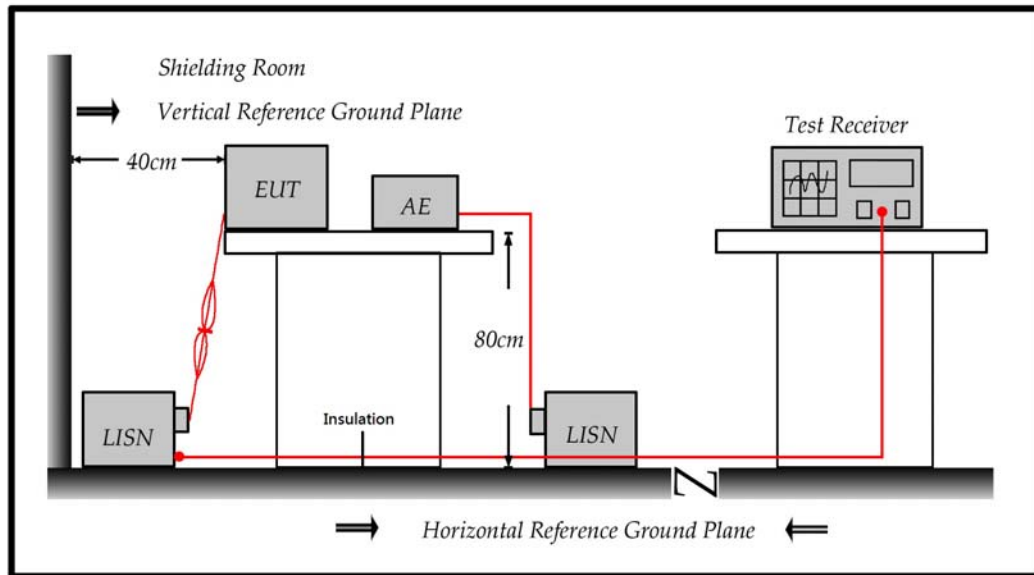

#### 3.3. Limit

| Applicable to<br>AC mains power ports |                 |                             |                          |
|---------------------------------------|-----------------|-----------------------------|--------------------------|
| Frequency range<br>MHz                | Coupling device | Detector type/<br>Bandwidth | Class A limits<br>dB(μV) |
| 0.15 – 0.5                            | AMN             | Quasi Peak / 9 KHz          | 79                       |
| 0.5 – 30                              |                 |                             | 73                       |
| 0.15 – 0.5                            | AMN             | Average / 9 KHz             | 66                       |
| 0.5 – 30                              |                 |                             | 60                       |

Both apply across the entire frequency range.

Remarks:

If the limits for the average detector are met when using the quasi-peak detector, then the limits for the measurement with the average detector are considered to be met.

### **3.4. Test Procedure**

The EUT and simulators are connected to the main power through a line impedance stabilization network (L.I.S.N.). This provides a 50 ohm /50uH coupling impedance for the measuring equipment. The peripheral devices are also connected to the main power through a LISN that provides a 50ohm/50uH coupling impedance with 50ohm termination.

(Please refers to the block diagram of the test setup and photographs.)

Both sides of A.C. line are checked for maximum conducted interference. In order to find the maximum emission, the relative positions of equipment and all of the interface cables must be changed according to VCCI on conducted measurement.

Conducted emissions were invested over the frequency range from 0.15MHz to 30MHz using a receiver bandwidth of 9kHz.

### **3.5. Deviation from Test Standard**

No deviation.

### 3.6. Test Result

|                        |                                |
|------------------------|--------------------------------|
| Site : SR1             | Time : 2018/10/29 - 13:05      |
| Limit : CISPR_A_00M_QP | Margin : 13                    |
| EUT : Network Camera   | Probe : ENV216_L1_1044 - Line1 |
| Power : AC 100V/50Hz   | Note: Mode 1                   |

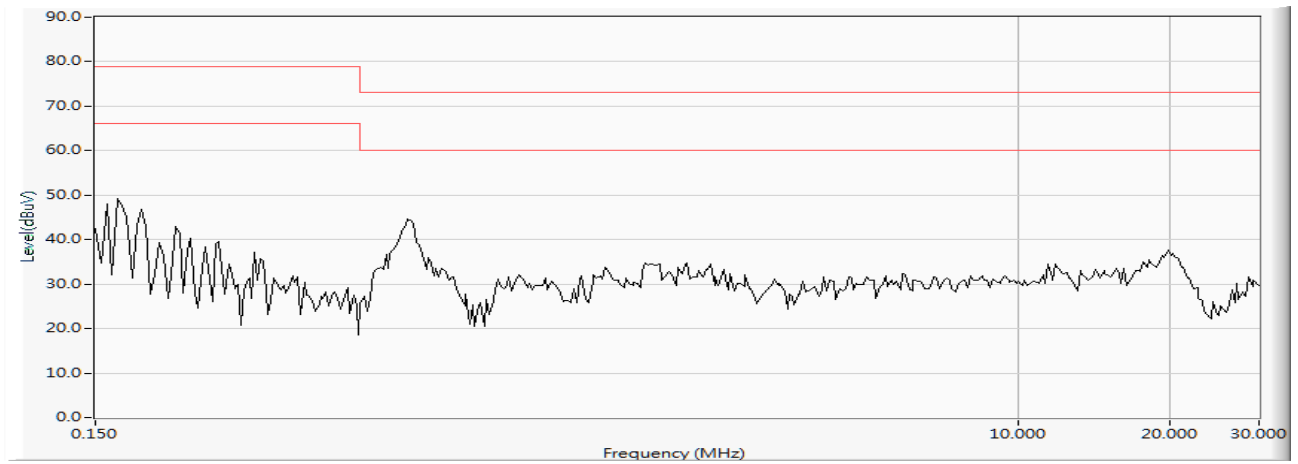

|                        |                                |
|------------------------|--------------------------------|
| Site : SR1             | Time : 2018/10/29 - 13:06      |
| Limit : CISPR_A_00M_QP | Margin : 0                     |
| EUT : Network Camera   | Probe : ENV216_L1_1044 - Line1 |
| Power : AC 100V/50Hz   | Note: Mode 1                   |

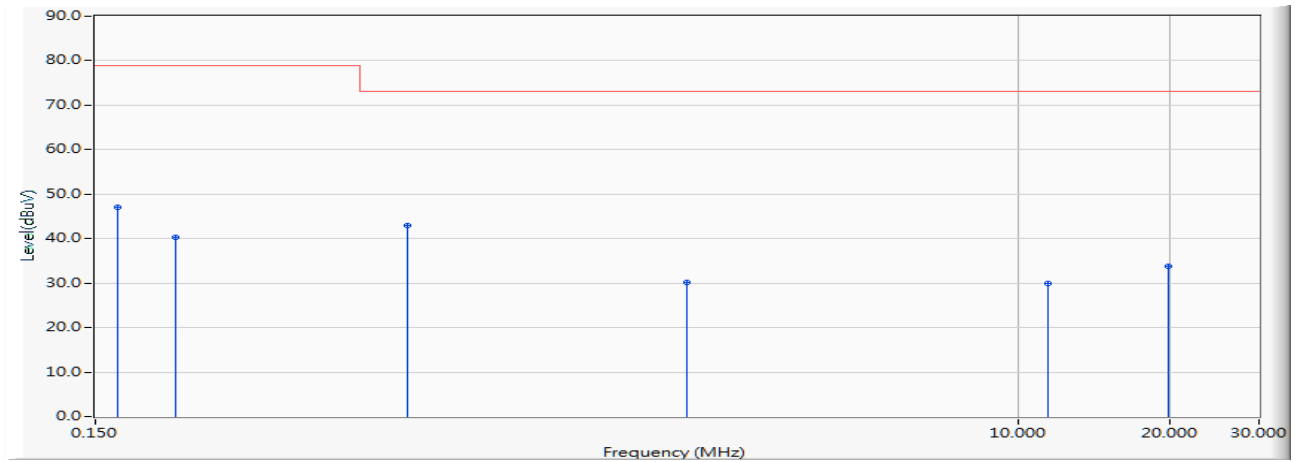

|   |   | Frequency (MHz) | Correct Factor (dB) | Reading Level (dBuV) | Measure Level (dBuV) | Margin (dB) | Limit (dBuV) | Detector Type |
|---|---|-----------------|---------------------|----------------------|----------------------|-------------|--------------|---------------|
| 1 |   | 0.166           | 9.705               | 37.410               | 47.115               | -31.885     | 79.000       | QUASIPeAK     |
| 2 |   | 0.216           | 9.707               | 30.520               | 40.227               | -38.773     | 79.000       | QUASIPeAK     |
| 3 | * | 0.623           | 9.710               | 33.320               | 43.030               | -29.970     | 73.000       | QUASIPeAK     |
| 4 |   | 2.220           | 9.780               | 20.410               | 30.190               | -42.810     | 73.000       | QUASIPeAK     |
| 5 |   | 11.466          | 10.056              | 19.920               | 29.976               | -43.024     | 73.000       | QUASIPeAK     |
| 6 |   | 19.892          | 10.211              | 23.640               | 33.851               | -39.149     | 73.000       | QUASIPeAK     |

Note:

1. All Reading Levels are Quasi-Peak and average value.
2. " \* ", means this data is the worst emission level.
3. Measurement Level = Reading Level + Correct Factor

|                        |                                |
|------------------------|--------------------------------|
| Site : SR1             | Time : 2018/10/29 - 13:06      |
| Limit : CISPR_A_00M_AV | Margin : 0                     |
| EUT : Network Camera   | Probe : ENV216_L1_1044 - Line1 |
| Power : AC 100V/50Hz   | Note: Mode 1                   |

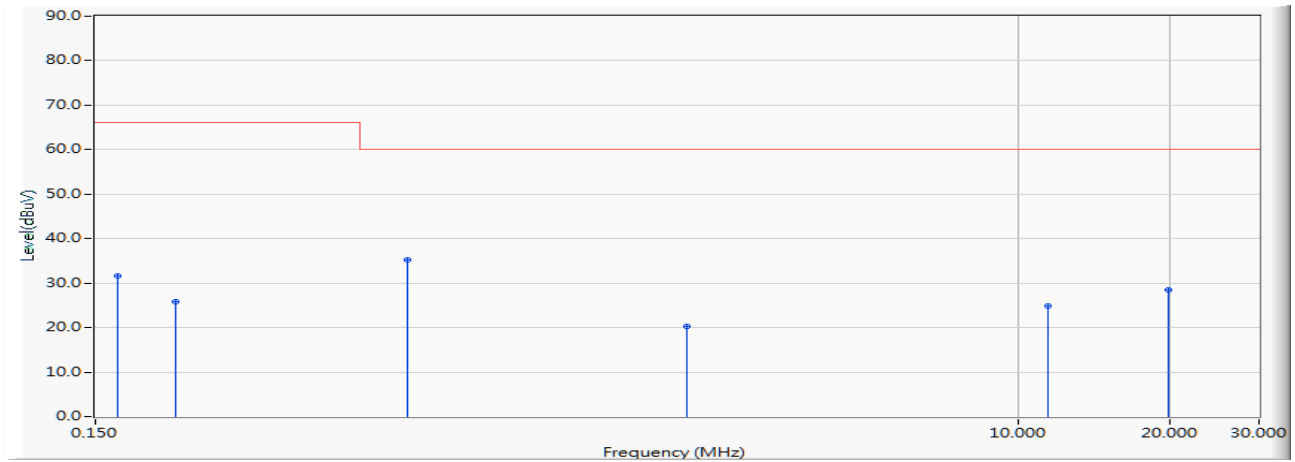

|   |   | Frequency (MHz) | Correct Factor (dB) | Reading Level (dBuV) | Measure Level (dBuV) | Margin (dB) | Limit (dBuV) | Detector Type |
|---|---|-----------------|---------------------|----------------------|----------------------|-------------|--------------|---------------|
| 1 |   | 0.166           | 9.705               | 21.930               | 31.635               | -34.365     | 66.000       | AVERAGE       |
| 2 |   | 0.216           | 9.707               | 16.080               | 25.787               | -40.213     | 66.000       | AVERAGE       |
| 3 | * | 0.623           | 9.710               | 25.400               | 35.110               | -24.890     | 60.000       | AVERAGE       |
| 4 |   | 2.220           | 9.780               | 10.480               | 20.260               | -39.740     | 60.000       | AVERAGE       |
| 5 |   | 11.466          | 10.056              | 14.770               | 24.826               | -35.174     | 60.000       | AVERAGE       |
| 6 |   | 19.892          | 10.211              | 18.370               | 28.581               | -31.419     | 60.000       | AVERAGE       |

Note:

1. All Reading Levels are Quasi-Peak and average value.
2. " \* ", means this data is the worst emission level.
3. Measurement Level = Reading Level + Correct Factor

|                               |                                      |
|-------------------------------|--------------------------------------|
| <b>Site : SR1</b>             | <b>Time : 2018/10/29 - 13:07</b>     |
| <b>Limit : CISPR_A_00M_QP</b> | <b>Margin : 13</b>                   |
| <b>EUT : Network Camera</b>   | <b>Probe : ENV216_N_1044 - Line2</b> |
| <b>Power : AC 100V/50Hz</b>   | <b>Note: Mode 1</b>                  |

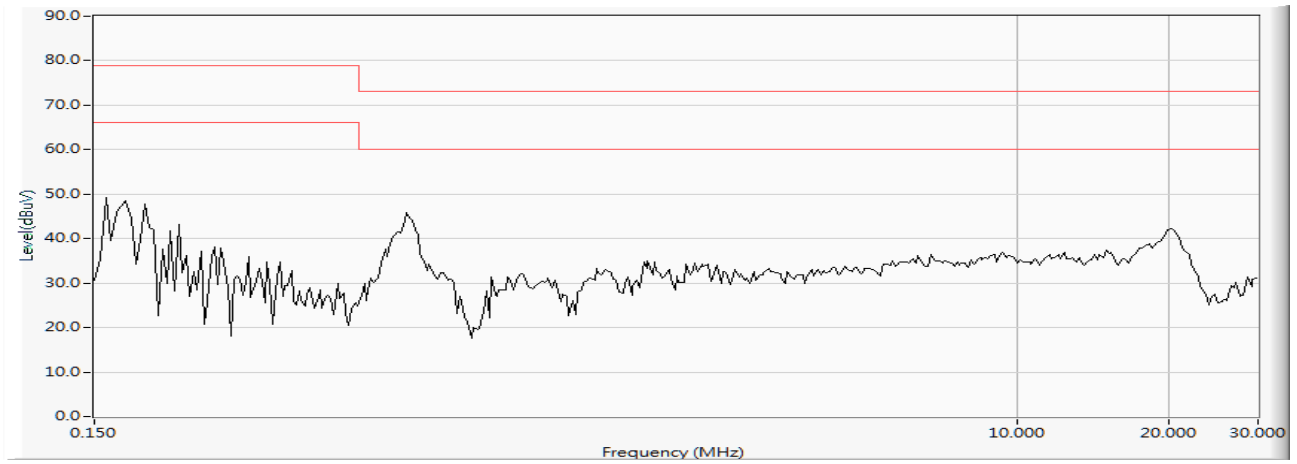

|                        |                               |
|------------------------|-------------------------------|
| Site : SR1             | Time : 2018/10/29 - 13:09     |
| Limit : CISPR_A_00M_QP | Margin : 0                    |
| EUT : Network Camera   | Probe : ENV216_N_1044 - Line2 |
| Power : AC 100V/50Hz   | Note: Mode 1                  |

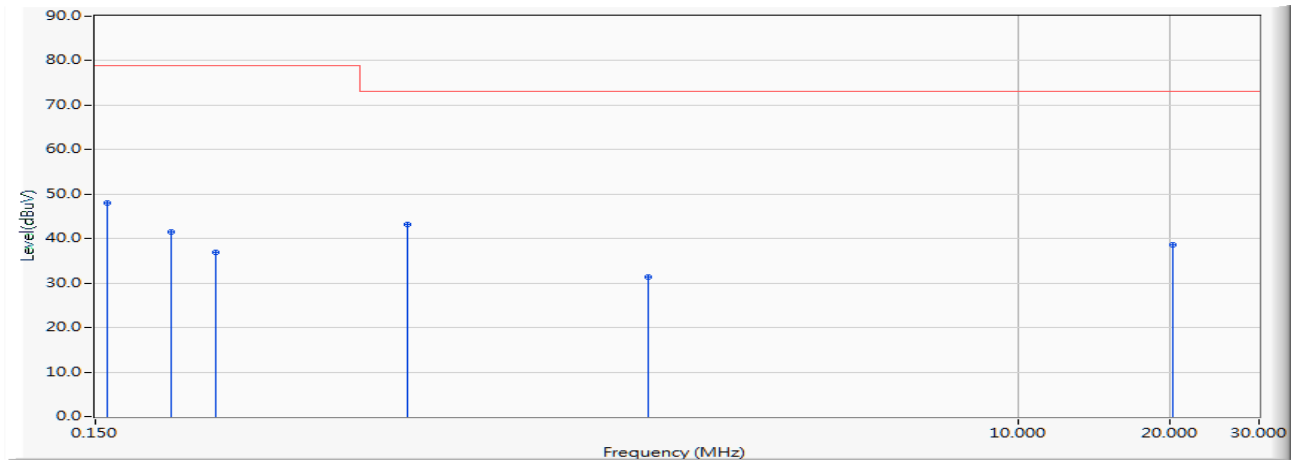

|   |   | Frequency (MHz) | Correct Factor (dB) | Reading Level (dBuV) | Measure Level (dBuV) | Margin (dB) | Limit (dBuV) | Detector Type |
|---|---|-----------------|---------------------|----------------------|----------------------|-------------|--------------|---------------|
| 1 |   | 0.158           | 9.685               | 38.320               | 48.005               | -30.995     | 79.000       | QUASPEAK      |
| 2 |   | 0.212           | 9.686               | 31.800               | 41.486               | -37.514     | 79.000       | QUASPEAK      |
| 3 |   | 0.259           | 9.688               | 27.130               | 36.818               | -42.182     | 79.000       | QUASPEAK      |
| 4 | * | 0.623           | 9.690               | 33.600               | 43.290               | -29.710     | 73.000       | QUASPEAK      |
| 5 |   | 1.865           | 9.749               | 21.510               | 31.259               | -41.741     | 73.000       | QUASPEAK      |
| 6 |   | 20.310          | 10.345              | 28.340               | 38.685               | -34.315     | 73.000       | QUASPEAK      |

Note:

1. All Reading Levels are Quasi-Peak and average value.
2. " \* ", means this data is the worst emission level.
3. Measurement Level = Reading Level + Correct Factor

|                        |                               |
|------------------------|-------------------------------|
| Site : SR1             | Time : 2018/10/29 - 13:09     |
| Limit : CISPR_A_00M_AV | Margin : 0                    |
| EUT : Network Camera   | Probe : ENV216_N_1044 - Line2 |
| Power : AC 100V/50Hz   | Note: Mode 1                  |

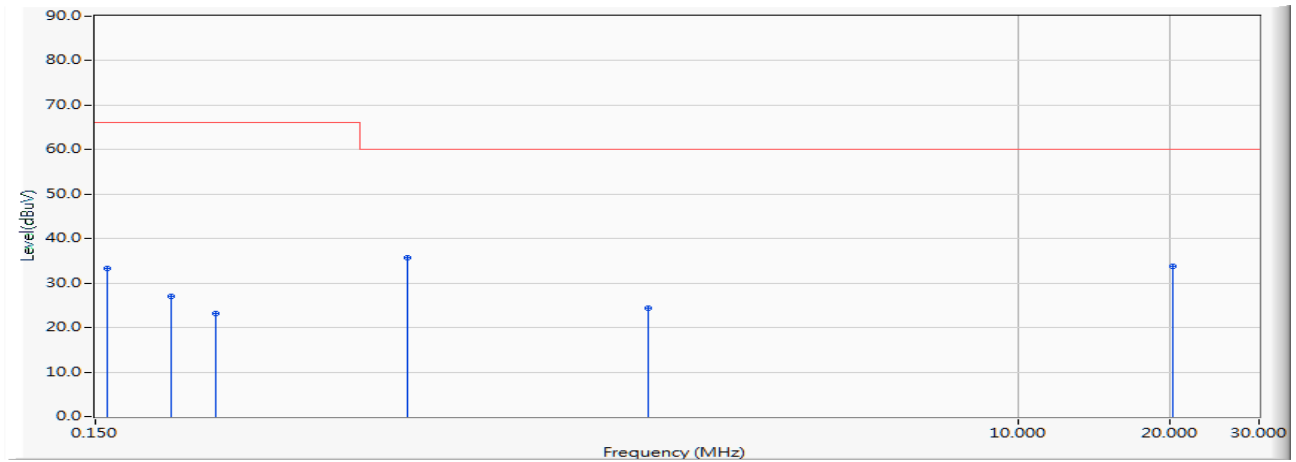

|   |   | Frequency (MHz) | Correct Factor (dB) | Reading Level (dBuV) | Measure Level (dBuV) | Margin (dB) | Limit (dBuV) | Detector Type |
|---|---|-----------------|---------------------|----------------------|----------------------|-------------|--------------|---------------|
| 1 |   | 0.158           | 9.685               | 23.510               | 33.195               | -32.805     | 66.000       | AVERAGE       |
| 2 |   | 0.212           | 9.686               | 17.270               | 26.956               | -39.044     | 66.000       | AVERAGE       |
| 3 |   | 0.259           | 9.688               | 13.530               | 23.218               | -42.782     | 66.000       | AVERAGE       |
| 4 | * | 0.623           | 9.690               | 25.920               | 35.610               | -24.390     | 60.000       | AVERAGE       |
| 5 |   | 1.865           | 9.749               | 14.530               | 24.279               | -35.721     | 60.000       | AVERAGE       |
| 6 |   | 20.310          | 10.345              | 23.500               | 33.845               | -26.155     | 60.000       | AVERAGE       |

Note:

1. All Reading Levels are Quasi-Peak and average value.
2. " \* ", means this data is the worst emission level.
3. Measurement Level = Reading Level + Correct Factor

### 3.7. Test Photograph

Test Mode : Mode 1: IB9387-EH , DC

Description : Front View of Conducted Test



Test Mode : Mode 1: IB9387-EH , DC

Description : Back View of Conducted Test



Test Mode : Mode 1: IB9387-EH , DC

Description : Back View of Conducted Test

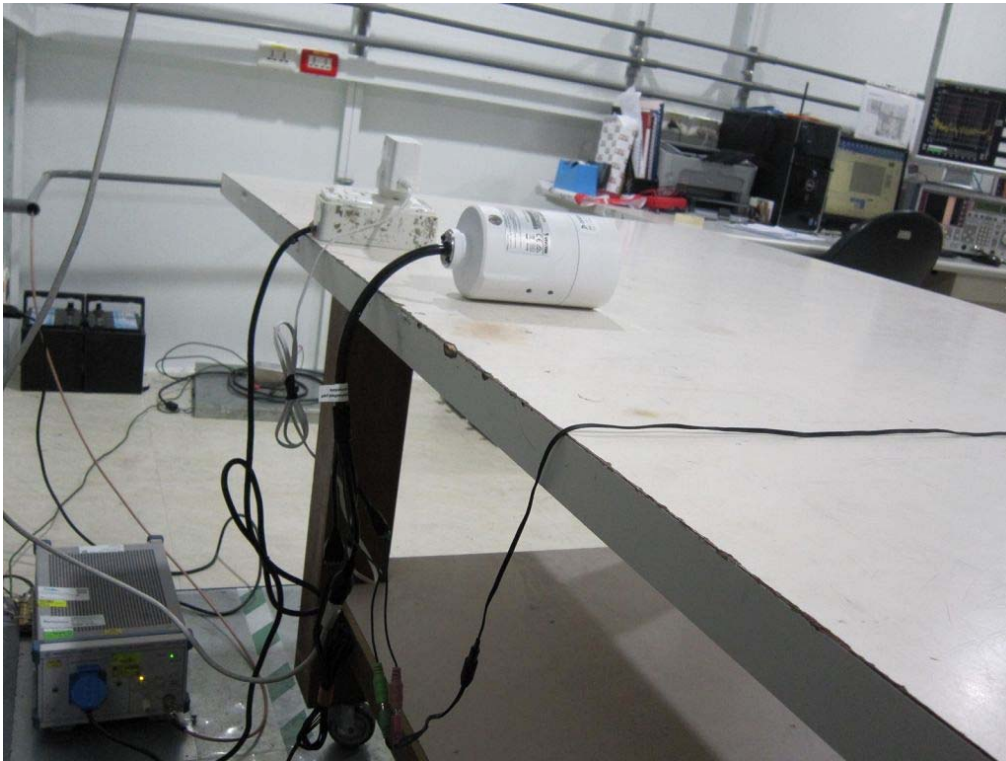

## 4. Conducted Emissions (Telecommunication Ports)

### 4.1. Test Specification

According to EMC Standard: VCCI CISPR 32

### 4.2. Test Setup

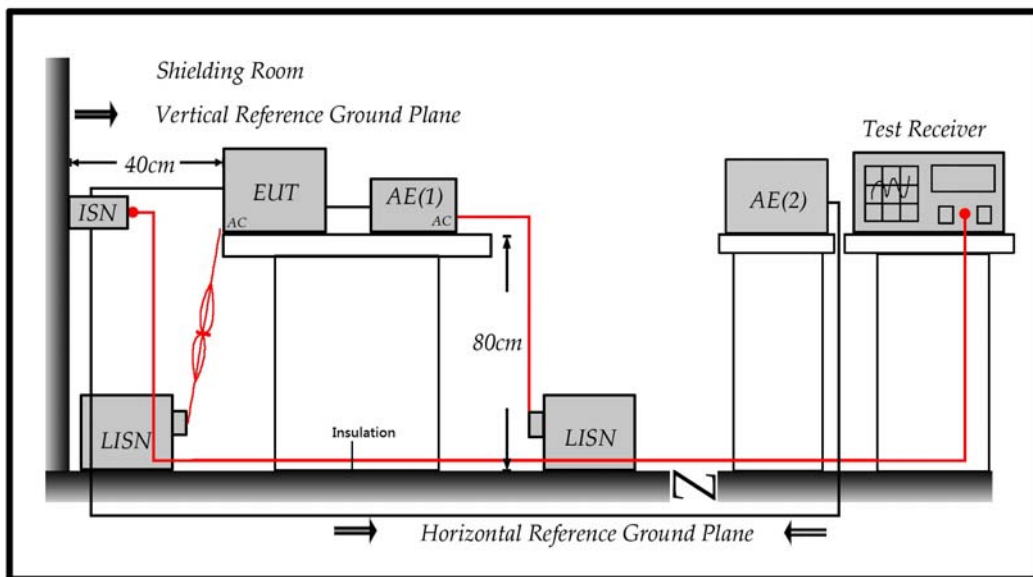

### 4.3. Limit

| Applicable to   |                          |                           |                               |                               |
|---|--------------------------|---------------------------|-------------------------------|-------------------------------|
| 1. wired network ports  |                          |                           |                               |                               |
| 2. optical fibre port with metallic shield or tension members |                          |                           |                               |                               |
| 3. antenna ports  |                          |                           |                               |                               |
| Frequency range MHz   | Coupling device          | Detector type / Bandwidth | Class A voltage limits dB(µV) | Class A current limits dB(µA) |
| 0.15 – 0.5  | AAN                      | Quasi Peak / 9 KHz        | 97 – 87                       | N / A                         |
| 0.5 – 30  |                          |                           | 87                            |                               |
| 0.15 – 0.5  | AAN                      | Average / 9 KHz           | 84 – 74                       |                               |
| 0.5 – 30  |                          |                           | 74                            |                               |
| 0.15 – 0.5  | CVP<br>And current probe | Quasi Peak / 9 KHz        | 97 – 87                       | 53 – 43                       |
| 0.5 – 30  |                          |                           | 87                            | 43                            |
| 0.15 – 0.5  | CVP<br>And current probe | Average / 9 KHz           | 84 – 74                       | 40 – 30                       |
| 0.5 – 30  |                          |                           | 74                            | 30                            |
| 0.15 – 0.5  | Current Probe            | Quasi Peak / 9 KHz        | N / A                         | 53 – 43                       |
| 0.5 – 30  |                          |                           |                               | 43                            |
| 0.15 – 0.5  | Current Probe            | Average / 9 KHz           |                               | 40 – 30                       |
| 0.5 – 30  |                          |                           |                               | 30                            |

The choice of coupling device and measurement procedure is defined in Annex C.

AC mains ports that also have the function of a wired network port shall meet the limits given in Table A.9.

The measurement shall cover the entire frequency range.

The application of the voltage and/or current limits is dependent on the measurement procedure used. Refer to Table C.1 of CISPR 32 for applicability.

Testing is required at only one EUT supply voltage and frequency.

Applicable to ports listed above and intended to connect to cables longer than 3 m.

#### **4.4. Test Procedure**

##### **Telecommunication Port:**

The mains voltage shall be supplied to the EUT via the LISN when the measurement of telecommunication port is performed. The common mode disturbances at the telecommunication port shall be connected to the ISN, which is 150 ohm impedance.

Both alternative cables are tested related to the LCL requested. The measurement range is from 150kHz to 30MHz. The bandwidth of measurement is set to 9kHz.

The 75dB LCL ISN is used for cat. 6 cable, the 65dB LCL ISN is used for cat. 5 cable, 55dB LCL ISN is used for cat. 3.

#### **4.5. Deviation from Test Standard**

No deviation.

### 4.6. Test Result

|                              |                                |
|------------------------------|--------------------------------|
| Site : SR1                   | Time : 2018/10/29 - 13:12      |
| Limit : ISN_Voltage_A_00M_QP | Margin : 13                    |
| EUT : Network Camera         | Probe : TESEQ_T8_30303 - Line1 |
| Power : AC 100V/50Hz         | Note: Mode 1, ISN 10M          |

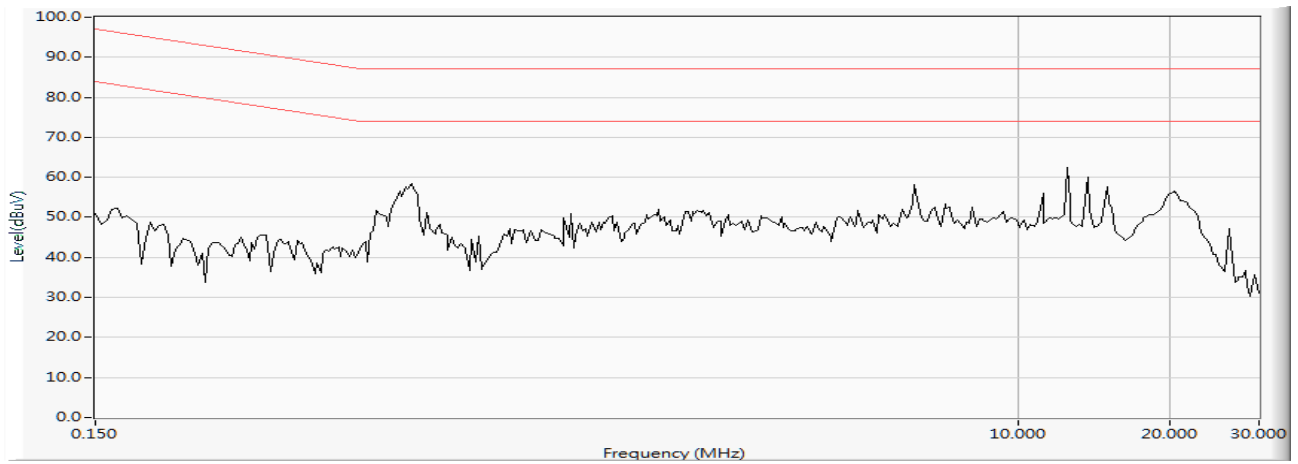

|                              |                                |
|------------------------------|--------------------------------|
| Site : SR1                   | Time : 2018/10/29 - 13:13      |
| Limit : ISN_Voltage_A_00M_QP | Margin : 0                     |
| EUT : Network Camera         | Probe : TESEQ_T8_30303 - Line1 |
| Power : AC 100V/50Hz         | Note: Mode 1, ISN 10M          |

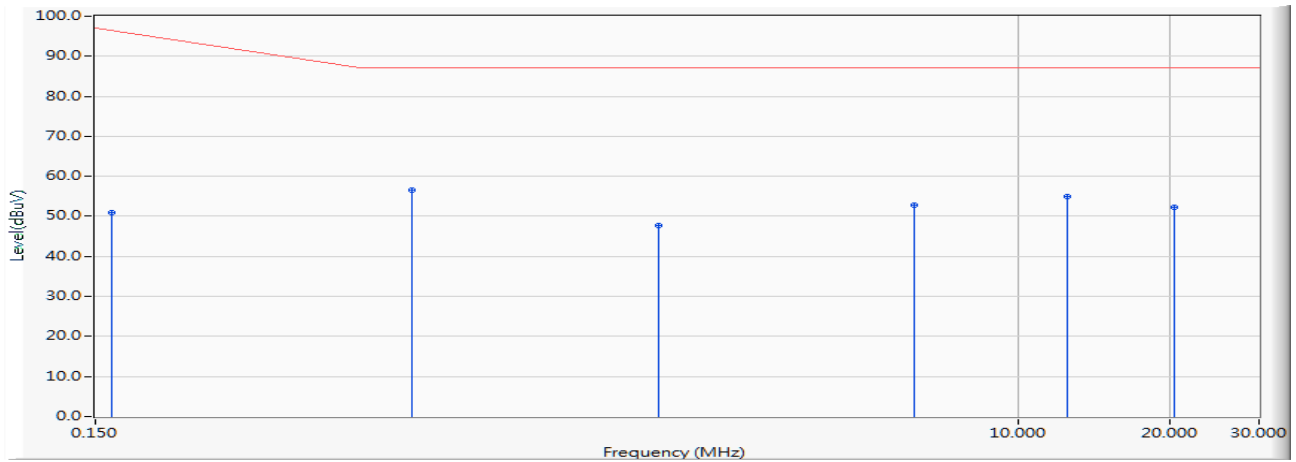

|   |   | Frequency (MHz) | Correct Factor (dB) | Reading Level (dBuV) | Measure Level (dBuV) | Margin (dB) | Limit (dBuV) | Detector Type |
|---|---|-----------------|---------------------|----------------------|----------------------|-------------|--------------|---------------|
| 1 |   | 0.162           | 10.096              | 40.960               | 51.056               | -45.601     | 96.657       | QUASIPeAK     |
| 2 | * | 0.634           | 9.688               | 46.990               | 56.678               | -30.322     | 87.000       | QUASIPeAK     |
| 3 |   | 1.947           | 9.602               | 38.000               | 47.602               | -39.398     | 87.000       | QUASIPeAK     |
| 4 |   | 6.248           | 9.653               | 43.180               | 52.833               | -34.167     | 87.000       | QUASIPeAK     |
| 5 |   | 12.502          | 9.780               | 45.210               | 54.990               | -32.010     | 87.000       | QUASIPeAK     |
| 6 |   | 20.435          | 9.976               | 42.320               | 52.296               | -34.704     | 87.000       | QUASIPeAK     |

Note:

1. All Reading Levels are Quasi-Peak and average value.
2. " \* ", means this data is the worst emission level.
3. Measurement Level = Reading Level + Correct Factor

|                              |                                |
|------------------------------|--------------------------------|
| Site : SR1                   | Time : 2018/10/29 - 13:13      |
| Limit : ISN_Voltage_A_00M_AV | Margin : 0                     |
| EUT : Network Camera         | Probe : TESEQ_T8_30303 - Line1 |
| Power : AC 100V/50Hz         | Note: Mode 1, ISN 10M          |

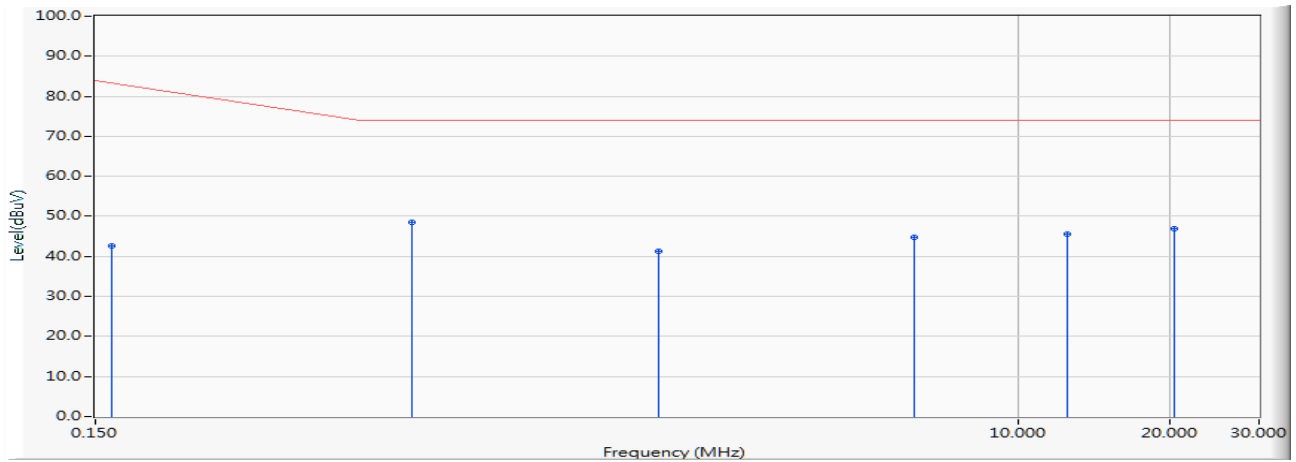

|   |   | Frequency (MHz) | Correct Factor (dB) | Reading Level (dBuV) | Measure Level (dBuV) | Margin (dB) | Limit (dBuV) | Detector Type |
|---|---|-----------------|---------------------|----------------------|----------------------|-------------|--------------|---------------|
| 1 |   | 0.162           | 10.096              | 32.650               | 42.746               | -40.911     | 83.657       | AVERAGE       |
| 2 | * | 0.634           | 9.688               | 38.730               | 48.418               | -25.582     | 74.000       | AVERAGE       |
| 3 |   | 1.947           | 9.602               | 31.580               | 41.182               | -32.818     | 74.000       | AVERAGE       |
| 4 |   | 6.248           | 9.653               | 35.180               | 44.833               | -29.167     | 74.000       | AVERAGE       |
| 5 |   | 12.502          | 9.780               | 35.810               | 45.590               | -28.410     | 74.000       | AVERAGE       |
| 6 |   | 20.435          | 9.976               | 37.000               | 46.976               | -27.024     | 74.000       | AVERAGE       |

Note:

1. All Reading Levels are Quasi-Peak and average value.
2. " \* ", means this data is the worst emission level.
3. Measurement Level = Reading Level + Correct Factor

|                              |                                |
|------------------------------|--------------------------------|
| Site : SR1                   | Time : 2018/10/29 - 13:14      |
| Limit : ISN_Voltage_A_00M_QP | Margin : 13                    |
| EUT : Network Camera         | Probe : TESEQ_T8_30303 - Line1 |
| Power : AC 100V/50Hz         | Note: Mode 1, ISN 100M         |

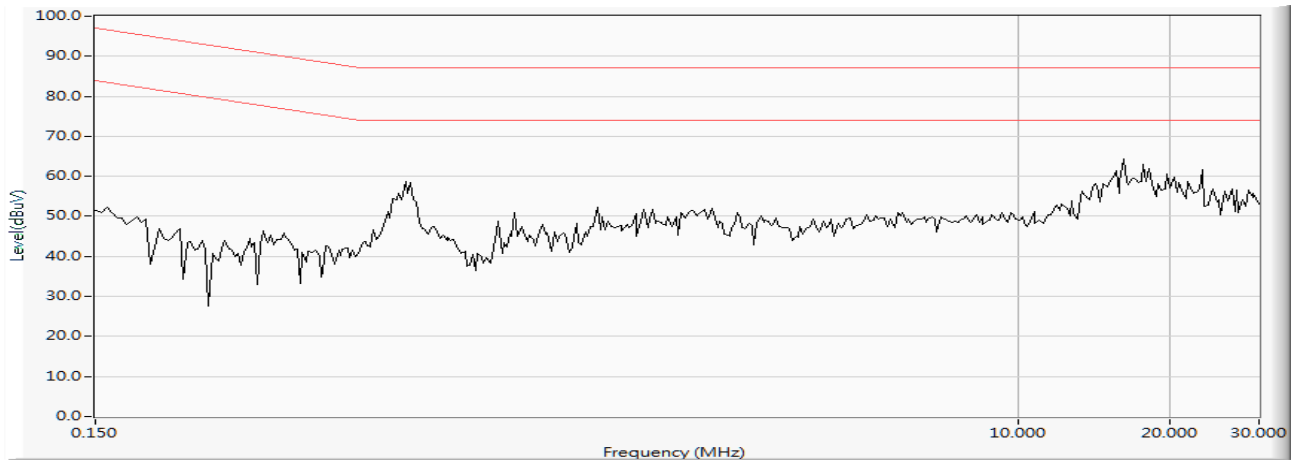

|                              |                                |
|------------------------------|--------------------------------|
| Site : SR1                   | Time : 2018/10/29 - 13:17      |
| Limit : ISN_Voltage_A_00M_QP | Margin : 0                     |
| EUT : Network Camera         | Probe : TESEQ_T8_30303 - Line1 |
| Power : AC 100V/50Hz         | Note: Mode 1,, ISN 100M        |

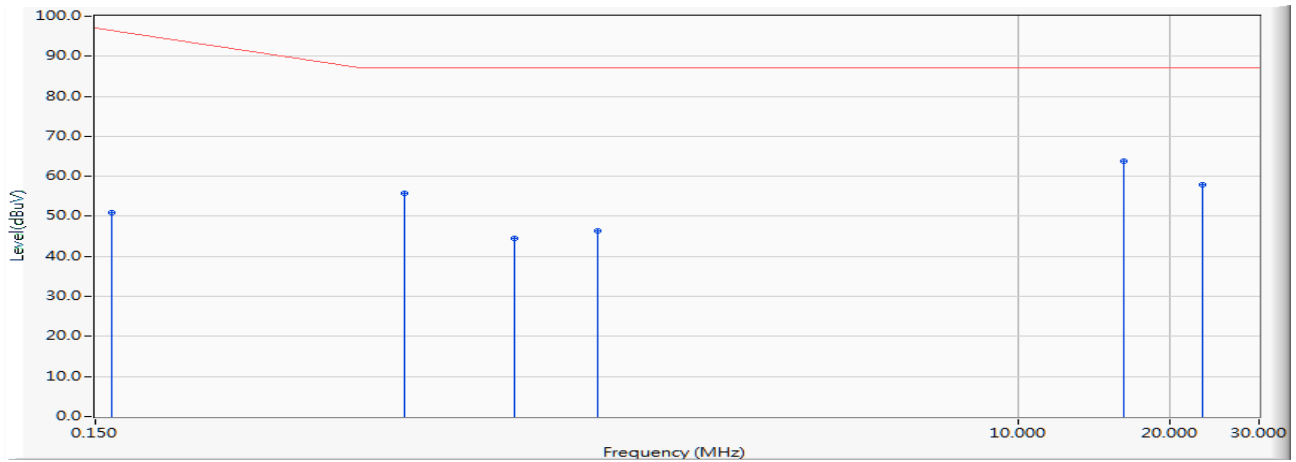

|   |   | Frequency (MHz) | Correct Factor (dB) | Reading Level (dBuV) | Measure Level (dBuV) | Margin (dB) | Limit (dBuV) | Detector Type |
|---|---|-----------------|---------------------|----------------------|----------------------|-------------|--------------|---------------|
| 1 |   | 0.162           | 10.096              | 40.880               | 50.976               | -45.681     | 96.657       | QUASIPeAK     |
| 2 |   | 0.611           | 9.695               | 46.040               | 55.735               | -31.265     | 87.000       | QUASIPeAK     |
| 3 |   | 1.009           | 9.642               | 34.930               | 44.572               | -42.428     | 87.000       | QUASIPeAK     |
| 4 |   | 1.478           | 9.627               | 36.710               | 46.337               | -40.663     | 87.000       | QUASIPeAK     |
| 5 | * | 16.228          | 9.881               | 54.010               | 63.891               | -23.109     | 87.000       | QUASIPeAK     |
| 6 |   | 23.130          | 10.060              | 47.810               | 57.870               | -29.130     | 87.000       | QUASIPeAK     |

Note:

1. All Reading Levels are Quasi-Peak and average value.
2. " \* ", means this data is the worst emission level.
3. Measurement Level = Reading Level + Correct Factor

|                              |                                |
|------------------------------|--------------------------------|
| Site : SR1                   | Time : 2018/10/29 - 13:17      |
| Limit : ISN_Voltage_A_00M_AV | Margin : 0                     |
| EUT : Network Camera         | Probe : TESEQ_T8_30303 - Line1 |
| Power : AC 100V/50Hz         | Note: Mode 1, ISN 100M         |

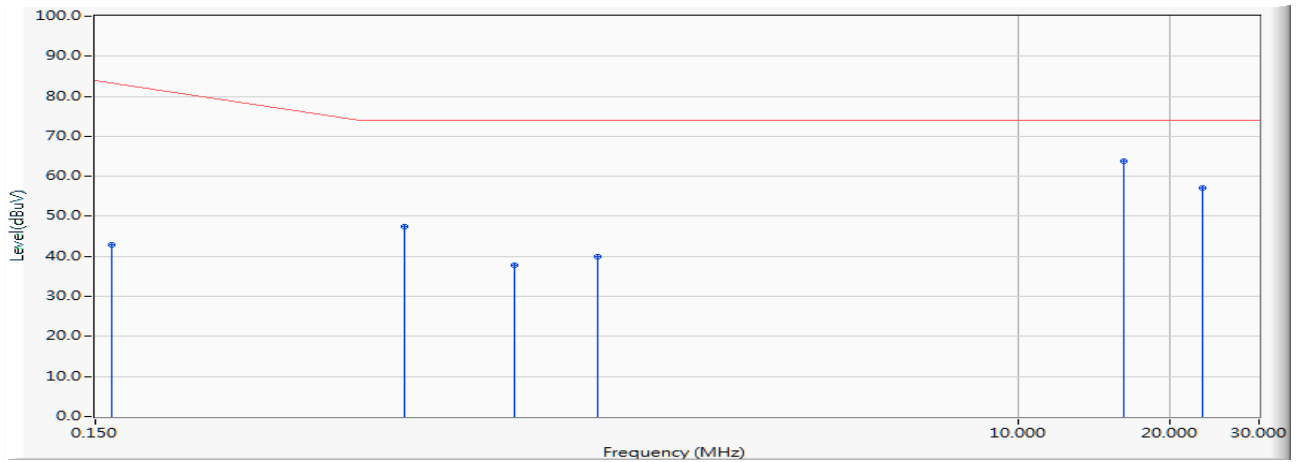

|   |   | Frequency (MHz) | Correct Factor (dB) | Reading Level (dBuV) | Measure Level (dBuV) | Margin (dB) | Limit (dBuV) | Detector Type |
|---|---|-----------------|---------------------|----------------------|----------------------|-------------|--------------|---------------|
| 1 |   | 0.162           | 10.096              | 32.800               | 42.896               | -40.761     | 83.657       | AVERAGE       |
| 2 |   | 0.611           | 9.695               | 37.700               | 47.395               | -26.605     | 74.000       | AVERAGE       |
| 3 |   | 1.009           | 9.642               | 28.240               | 37.882               | -36.118     | 74.000       | AVERAGE       |
| 4 |   | 1.478           | 9.627               | 30.330               | 39.957               | -34.043     | 74.000       | AVERAGE       |
| 5 | * | 16.228          | 9.881               | 53.970               | 63.851               | -10.149     | 74.000       | AVERAGE       |
| 6 |   | 23.130          | 10.060              | 47.120               | 57.180               | -16.820     | 74.000       | AVERAGE       |

Note:

1. All Reading Levels are Quasi-Peak and average value.
2. " \* ", means this data is the worst emission level.
3. Measurement Level = Reading Level + Correct Factor

|                                     |                                       |
|-------------------------------------|---------------------------------------|
| <b>Site : SR1</b>                   | <b>Time : 2018/10/29 - 14:08</b>      |
| <b>Limit : ISN_Voltage_A_00M_QP</b> | <b>Margin : 13</b>                    |
| <b>EUT : Network Camera</b>         | <b>Probe : TESEQ_T8_30303 - Line1</b> |
| <b>Power : By PoE</b>               | <b>Note: Mode 2, ISN 10M</b>          |

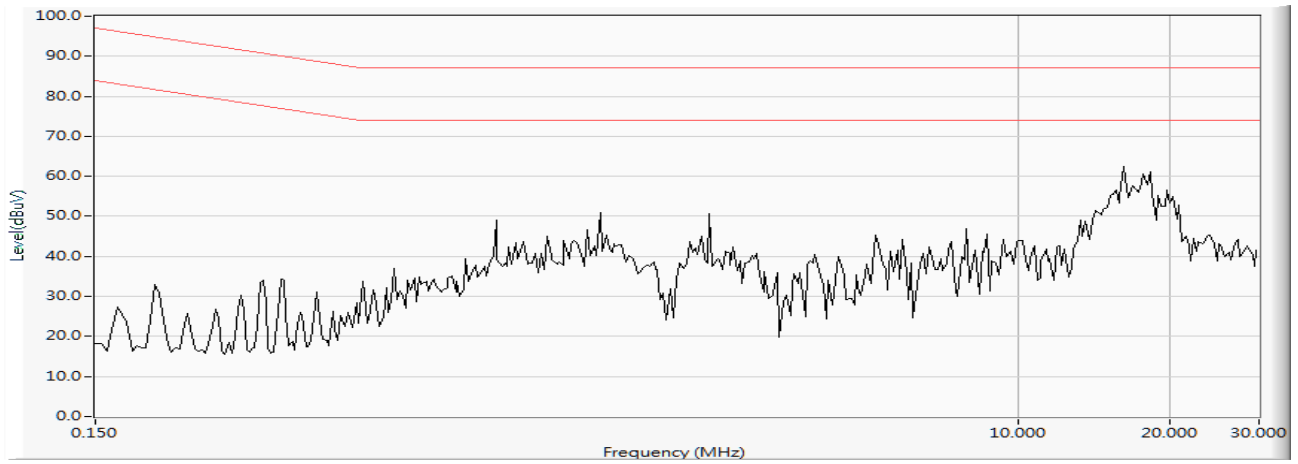

|                              |                                |
|------------------------------|--------------------------------|
| Site : SR1                   | Time : 2018/10/29 - 14:09      |
| Limit : ISN_Voltage_A_00M_QP | Margin : 0                     |
| EUT : Network Camera         | Probe : TESEQ_T8_30303 - Line1 |
| Power : By PoE               | Note: Mode 2, ISN 10M          |

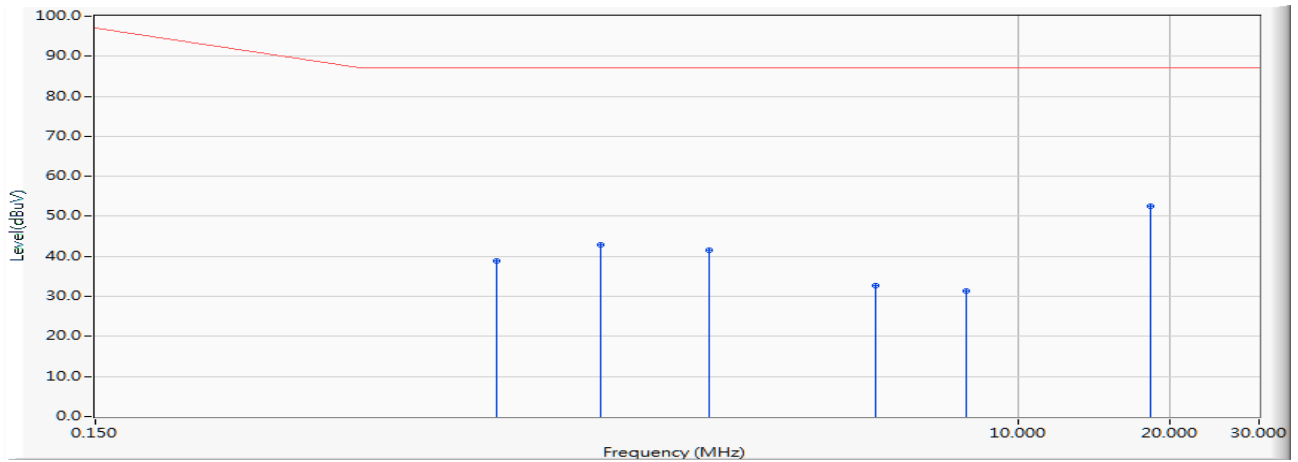

|   |   | Frequency (MHz) | Correct Factor (dB) | Reading Level (dBuV) | Measure Level (dBuV) | Margin (dB) | Limit (dBuV) | Detector Type |
|---|---|-----------------|---------------------|----------------------|----------------------|-------------|--------------|---------------|
| 1 |   | 0.931           | 9.647               | 29.360               | 39.008               | -47.992     | 87.000       | QUASIPeAK     |
| 2 |   | 1.498           | 9.626               | 33.310               | 42.936               | -44.064     | 87.000       | QUASIPeAK     |
| 3 |   | 2.455           | 9.607               | 31.910               | 41.517               | -45.483     | 87.000       | QUASIPeAK     |
| 4 |   | 5.236           | 9.635               | 23.060               | 32.695               | -54.305     | 87.000       | QUASIPeAK     |
| 5 |   | 7.923           | 9.680               | 21.780               | 31.460               | -55.540     | 87.000       | QUASIPeAK     |
| 6 | * | 18.306          | 9.920               | 42.510               | 52.430               | -34.570     | 87.000       | QUASIPeAK     |

Note:

1. All Reading Levels are Quasi-Peak and average value.
2. " \* ", means this data is the worst emission level.
3. Measurement Level = Reading Level + Correct Factor

|                              |                                |
|------------------------------|--------------------------------|
| Site : SR1                   | Time : 2018/10/29 - 14:09      |
| Limit : ISN_Voltage_A_00M_AV | Margin : 0                     |
| EUT : Network Camera         | Probe : TESEQ_T8_30303 - Line1 |
| Power : By PoE               | Note: Mode 2, ISN 10M          |

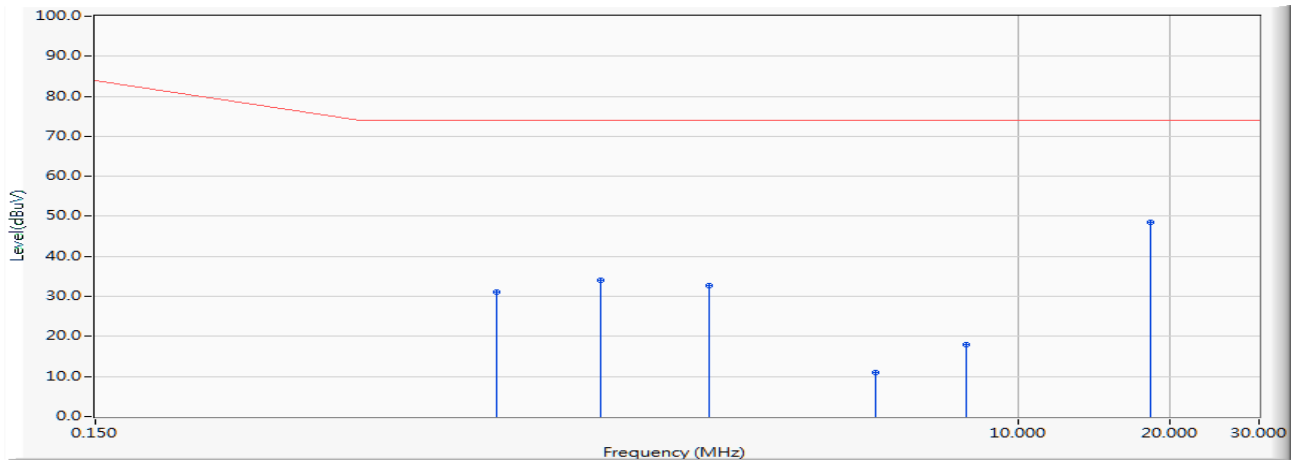

|   |   | Frequency (MHz) | Correct Factor (dB) | Reading Level (dBuV) | Measure Level (dBuV) | Margin (dB) | Limit (dBuV) | Detector Type |
|---|---|-----------------|---------------------|----------------------|----------------------|-------------|--------------|---------------|
| 1 |   | 0.931           | 9.647               | 21.470               | 31.118               | -42.882     | 74.000       | AVERAGE       |
| 2 |   | 1.498           | 9.626               | 24.300               | 33.926               | -40.074     | 74.000       | AVERAGE       |
| 3 |   | 2.455           | 9.607               | 23.040               | 32.647               | -41.353     | 74.000       | AVERAGE       |
| 4 |   | 5.236           | 9.635               | 1.300                | 10.935               | -63.065     | 74.000       | AVERAGE       |
| 5 |   | 7.923           | 9.680               | 8.230                | 17.910               | -56.090     | 74.000       | AVERAGE       |
| 6 | * | 18.306          | 9.920               | 38.660               | 48.580               | -25.420     | 74.000       | AVERAGE       |

Note:

1. All Reading Levels are Quasi-Peak and average value.
2. " \* ", means this data is the worst emission level.
3. Measurement Level = Reading Level + Correct Factor

|                              |                                |
|------------------------------|--------------------------------|
| Site : SR1                   | Time : 2018/10/29 - 14:11      |
| Limit : ISN_Voltage_A_00M_QP | Margin : 13                    |
| EUT : Network Camera         | Probe : TESEQ_T8_30303 - Line1 |
| Power : By PoE               | Note: Mode 2, ISN 100M         |

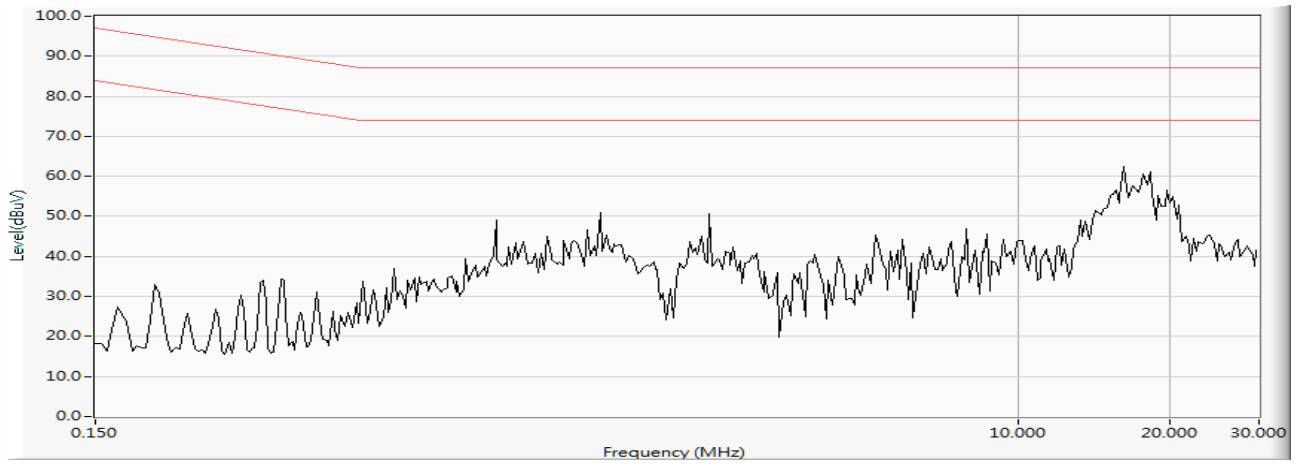

|                              |                                |
|------------------------------|--------------------------------|
| Site : SR1                   | Time : 2018/10/29 - 14:13      |
| Limit : ISN_Voltage_A_00M_QP | Margin : 0                     |
| EUT : Network Camera         | Probe : TESEQ_T8_30303 - Line1 |
| Power : By PoE               | Note: Mode 2, ISN 100M         |

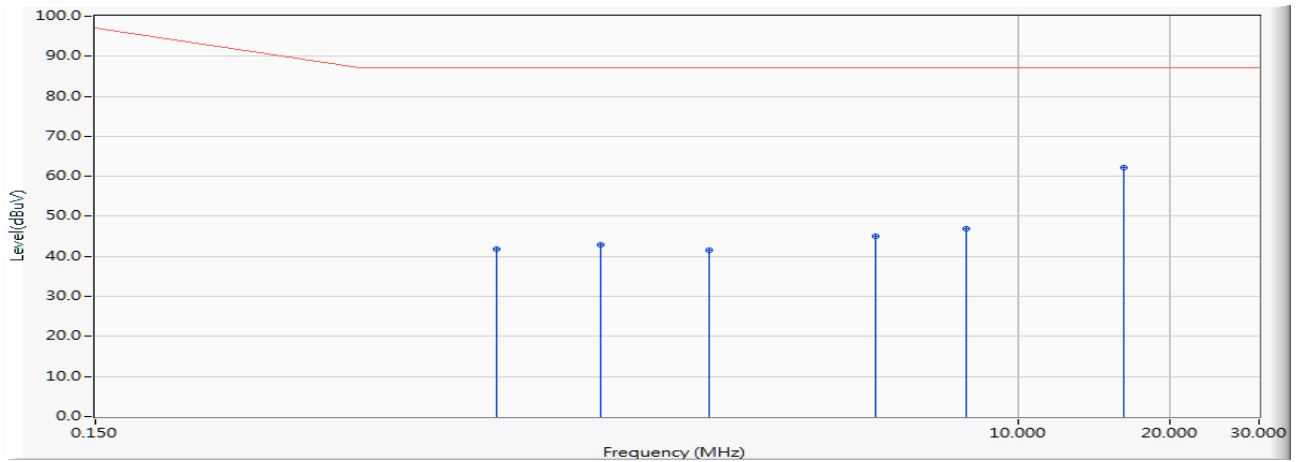

|   |   | Frequency (MHz) | Correct Factor (dB) | Reading Level (dBuV) | Measure Level (dBuV) | Margin (dB) | Limit (dBuV) | Detector Type |
|---|---|-----------------|---------------------|----------------------|----------------------|-------------|--------------|---------------|
| 1 |   | 0.931           | 9.647               | 32.290               | 41.938               | -45.062     | 87.000       | QUASIPeAK     |
| 2 |   | 1.498           | 9.626               | 33.330               | 42.956               | -44.044     | 87.000       | QUASIPeAK     |
| 3 |   | 2.455           | 9.607               | 31.850               | 41.457               | -45.543     | 87.000       | QUASIPeAK     |
| 4 |   | 5.236           | 9.635               | 35.520               | 45.155               | -41.845     | 87.000       | QUASIPeAK     |
| 5 |   | 7.923           | 9.680               | 37.370               | 47.050               | -39.950     | 87.000       | QUASIPeAK     |
| 6 | * | 16.228          | 9.881               | 52.430               | 62.311               | -24.689     | 87.000       | QUASIPeAK     |

Note:

1. All Reading Levels are Quasi-Peak and average value.
2. " \* ", means this data is the worst emission level.
3. Measurement Level = Reading Level + Correct Factor

|                              |                                |
|------------------------------|--------------------------------|
| Site : SR1                   | Time : 2018/10/29 - 14:13      |
| Limit : ISN_Voltage_A_00M_AV | Margin : 0                     |
| EUT : Network Camera         | Probe : TESEQ_T8_30303 - Line1 |
| Power : By PoE               | Note: Mode 2, ISN 100M         |

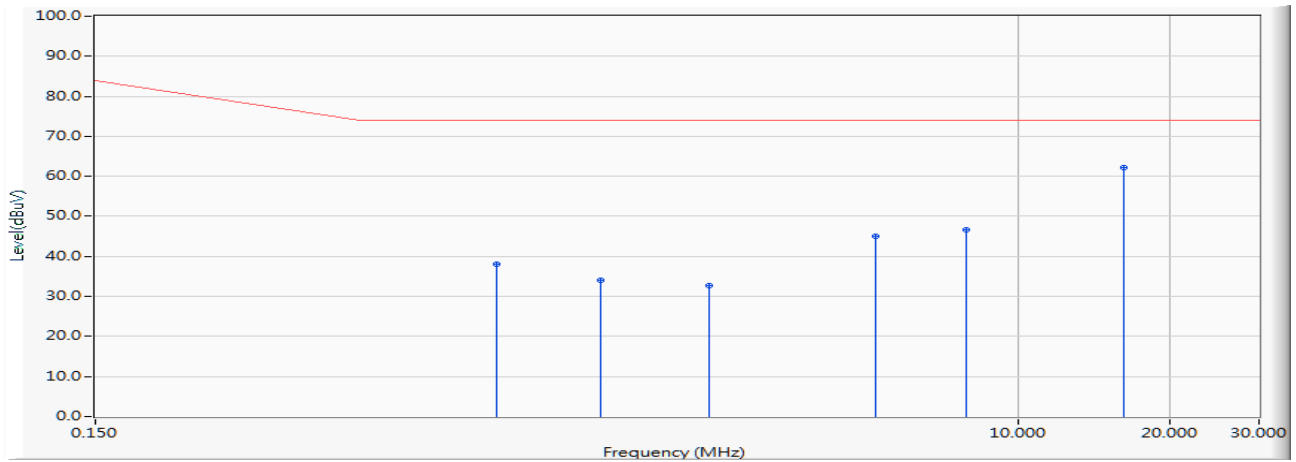

|   |   | Frequency (MHz) | Correct Factor (dB) | Reading Level (dBuV) | Measure Level (dBuV) | Margin (dB) | Limit (dBuV) | Detector Type |
|---|---|-----------------|---------------------|----------------------|----------------------|-------------|--------------|---------------|
| 1 |   | 0.931           | 9.647               | 28.520               | 38.168               | -35.832     | 74.000       | AVERAGE       |
| 2 |   | 1.498           | 9.626               | 24.340               | 33.966               | -40.034     | 74.000       | AVERAGE       |
| 3 |   | 2.455           | 9.607               | 23.140               | 32.747               | -41.253     | 74.000       | AVERAGE       |
| 4 |   | 5.236           | 9.635               | 35.500               | 45.135               | -28.865     | 74.000       | AVERAGE       |
| 5 |   | 7.923           | 9.680               | 37.090               | 46.770               | -27.230     | 74.000       | AVERAGE       |
| 6 | * | 16.228          | 9.881               | 52.420               | 62.301               | -11.699     | 74.000       | AVERAGE       |

Note:

1. All Reading Levels are Quasi-Peak and average value.
2. " \* ", means this data is the worst emission level.
3. Measurement Level = Reading Level + Correct Factor

#### 4.7. Test Photograph

Test Mode : Mode 1: IB9387-EH , DC

Description : Front View of ISN Test



Test Mode : Mode 1: IB9387-EH , DC

Description : Back View of ISN Test



Test Mode : Mode 1: IB9387-EH , DC

Description : Back View of ISN Test



Test Mode : Mode 2: IB9387-EH , PoE

Description : Front View of ISN Test



Test Mode : Mode 2: IB9387-EH , PoE

Description : Back View of ISN Test



Test Mode : Mode 2: IB9387-EH , PoE

Description : Back View of ISN Test



## 5. Radiated Emission

### 5.1. Test Specification

According to EMC Standard: VCCI CISPR 32

### 5.2. Test Setup

Under 1GHz Test Setup:

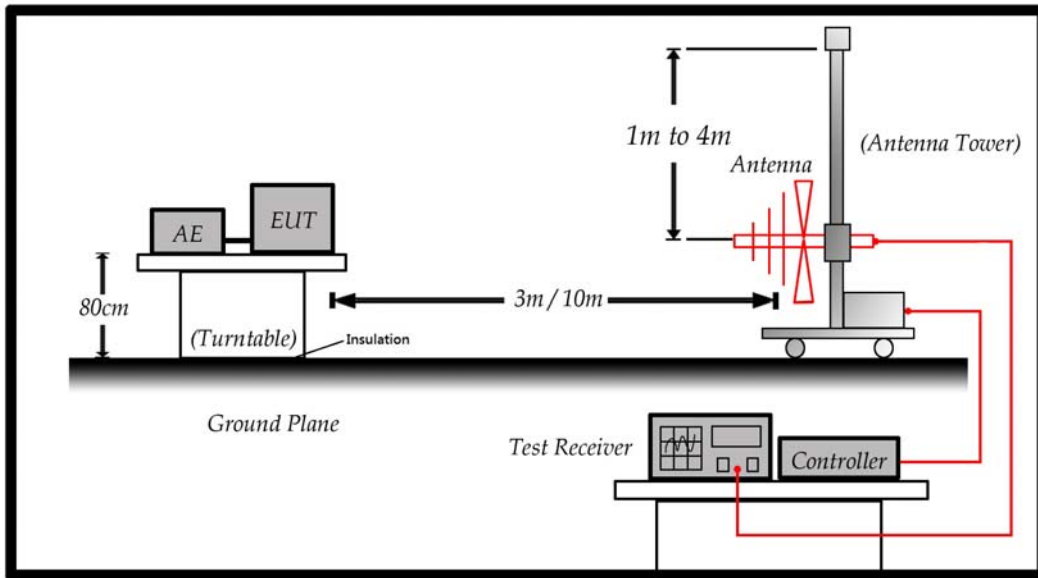

Above 1GHz Test Setup:

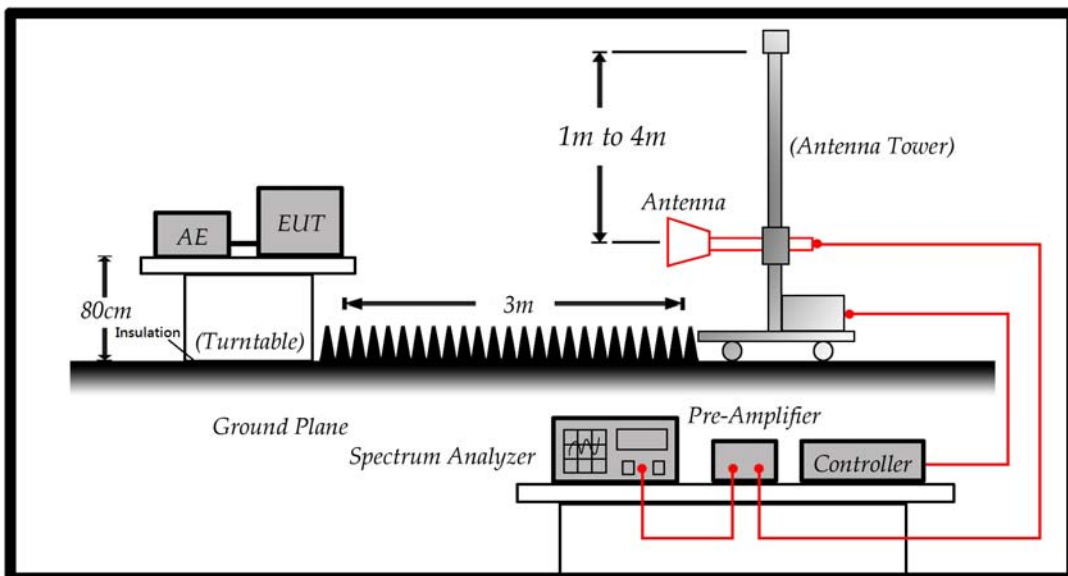

### 5.3. Limit

Radiated emissions at frequencies up to 1 GHz

for Class A equipment

| Frequency range<br>MHz                                 | Measurement   |                             | Class A limits dB( $\mu$ V/m) |
|--|---------------|-----------------------------|-------------------------------|
|  | Distance<br>m | Detector type/<br>Bandwidth | OATS / SAC                    |
| 30-230   | 10            | Quasi Peak /<br>120 KHz     | 40                            |
| 230-1000   |               |                             | 47                            |
| 30-230   | 3             |                             | 50                            |
| 230-1000   |               |                             | 57                            |
| Apply only 3m or 10m across the entire frequency range |               |                             |                               |

Radiated emissions at frequencies above 1 GHz

for Class A equipment

| Frequency range<br>MHz  | Measurement   |                             | Class A limits dB( $\mu$ V/m) |
|---|---------------|-----------------------------|-------------------------------|
|   | Distance<br>m | Detector type/<br>Bandwidth | OATS / SAC                    |
| 1000-3000   | 3             | Average /<br>1 MHz          | 56                            |
| 3000-6000   |               |                             | 60                            |
| 1000-3000   |               | Peak /<br>1 MHz             | 76                            |
| 3000-6000   |               |                             | 80                            |
| Both apply across the frequency range from 1000 MHz to the highest required frequency of measurement derived from |               |                             |                               |

Required highest frequency for radiated measurement

| Highest internal frequency<br>( $F_x$ )  | Highest measured frequency              |
|--|---|
| $F_x \leq 108$ MHz   | 1 GHz                                   |
| 108 MHz < $F_x \leq 500$ MHz   | 2 GHz                                   |
| 500 MHz < $F_x \leq 1$ GHz   | 5 GHz                                   |
| $F_x > 1$ GHz  | $5 \times F_x$ up to a maximum of 6 GHz |
| NOTE 1 For FM and TV broadcast receivers, $F_x$ is determined from the highest frequency generated or used excluding the local oscillator and tuned frequencies. |   |
| NOTE 2 $F_x$ is defined in 3.1.19.   |   |

#### **5.4. Test Procedure**

The EUT and its simulators are placed on a turn table which is 0.8 meter above ground. The turn table can rotate 360 degrees to determine the position of the maximum emission level. The EUT was positioned such that the distance from antenna to the EUT was 10 meters. The antenna can move up and down between 1 meter and 4 meters to find out the maximum emission level.

All cable leaving the table-top EUT for a connection outside the test site (for example, mains cable, telephone lines, connections to auxiliary equipment located outside the test area) shall be fitted with ferrite clamps placed on the floor at the point where the cable reached the floor. Both horizontal and vertical polarization of the antenna are set on measurement. In order to find the maximum emission, all of the interface cables must be manipulated according to VCCI on radiated measurement.

Radiated emissions were investigated over the frequency range from 30MHz to 1GHz using a receiver bandwidth of 120kHz. Radiated was performed at an antenna to EUT distance of 10 meters.

#### **5.5. Deviation from Test Standard**

No deviation.

### 5.6. Test Result

|                        |  |
|------------------------|--|
| Site : SITE7           | Time : 2018/10/29 - 19:37                    |
| Limit : CISPR_A_10M_QP | Margin : 6                                   |
| EUT : Network Camera   | Probe : Site7_VULB9168_10m_1804 - HORIZONTAL |
| Power : AC 100V/50Hz   | Note: Mode 1                                 |

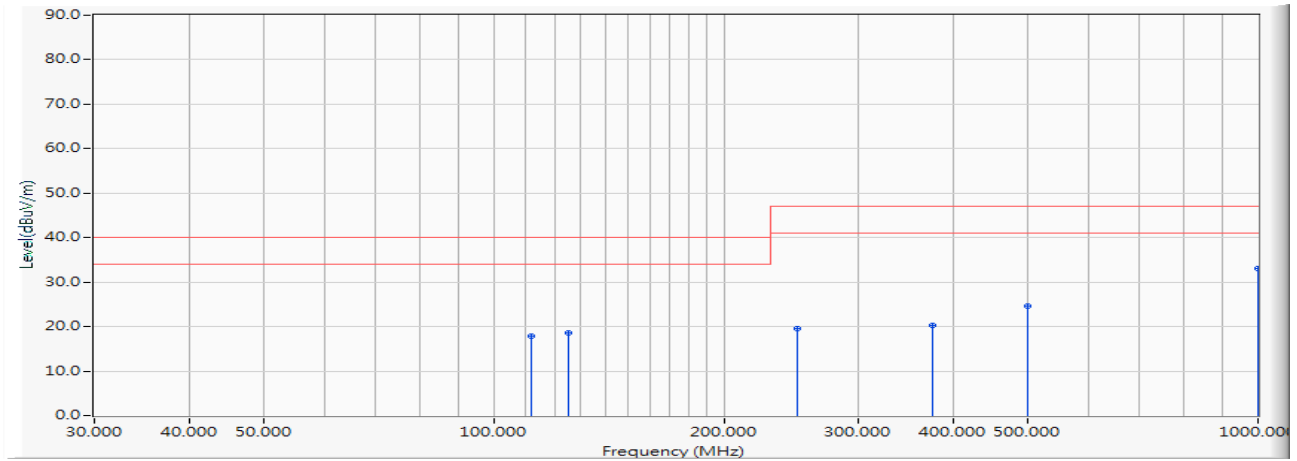

|   | Frequency (MHz) | Correct Factor (dB) | Reading Level (dBuV) | Measure Level (dBuV/m) | Margin (dB) | Limit (dBuV/m) | Detector Type | Ant Pos (cm) | Table Pos (deg) |
|---|-----------------|---------------------|----------------------|------------------------|-------------|----------------|---------------|--------------|-----------------|
| 1 | 112.100         | -13.746             | 31.600               | 17.854                 | -22.146     | 40.000         | QUASPEAK      | 400.000      | 54.000          |
| 2 | 125.000         | -12.407             | 31.000               | 18.594                 | -21.406     | 40.000         | QUASPEAK      | 390.000      | -4.000          |
| 3 | 250.000         | -10.388             | 30.000               | 19.612                 | -27.388     | 47.000         | QUASPEAK      | 375.000      | -19.000         |
| 4 | 375.000         | -5.843              | 26.000               | 20.157                 | -26.843     | 47.000         | QUASPEAK      | 320.000      | -21.000         |
| 5 | 500.000         | -1.909              | 26.400               | 24.491                 | -22.509     | 47.000         | QUASPEAK      | 200.000      | 68.000          |
| 6 | * 1000.000      | 7.730               | 25.400               | 33.130                 | -13.870     | 47.000         | QUASPEAK      | 100.000      | 34.000          |

**Note:**

1. All Readings below 1GHz are Quasi-Peak, above are performed with peak and/or average measurements as necessary.
2. " \* ", means this data is the worst emission level.
3. Measurement Level = Reading Level + Correct Factor

|                               |   |
|-------------------------------|---|
| <b>Site : SITE7</b>           | <b>Time : 2018/10/29 - 19:38</b>                  |
| <b>Limit : CISPR_A_10M_QP</b> | <b>Margin : 6</b>                                 |
| <b>EUT : Network Camera</b>   | <b>Probe : Site7_VULB9168_10m_1804 - VERTICAL</b> |
| <b>Power : AC 100V/50Hz</b>   | <b>Note: Mode 1</b>                               |

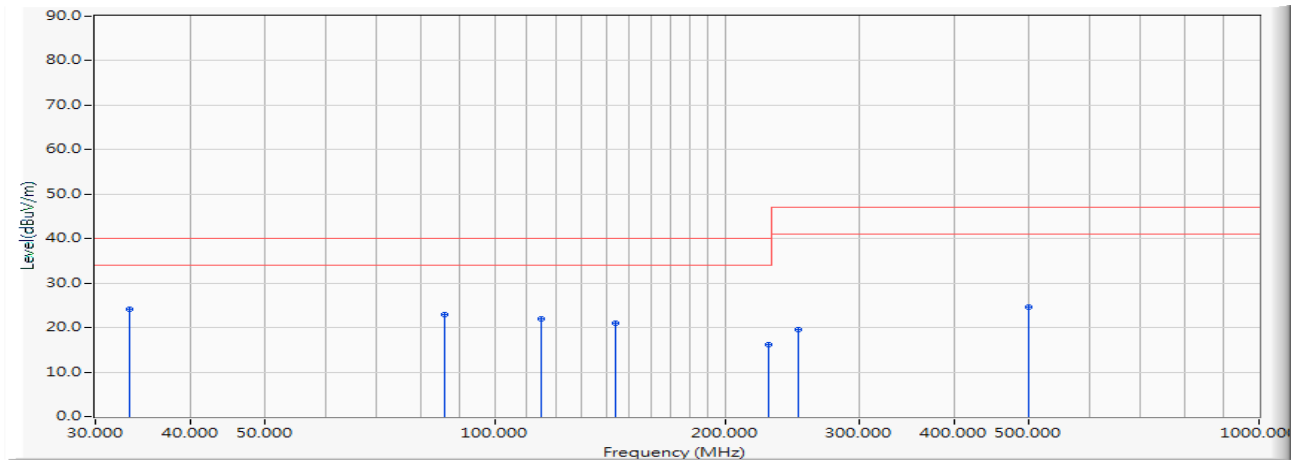

|   |   | Frequency (MHz) | Correct Factor (dB) | Reading Level (dBuV) | Measure Level (dBuV/m) | Margin (dB) | Limit (dBuV/m) | Detector Type | Ant Pos (cm) | Table Pos (deg) |
|---|---|-----------------|---------------------|----------------------|------------------------|-------------|----------------|---------------|--------------|-----------------|
| 1 | * | 33.300          | -12.872             | 37.000               | 24.128                 | -15.872     | 40.000         | QUASPEAK      | 100.000      | 62.000          |
| 2 |   | 86.060          | -16.389             | 39.400               | 23.011                 | -16.989     | 40.000         | QUASPEAK      | 100.000      | 52.000          |
| 3 |   | 115.100         | -13.434             | 35.300               | 21.866                 | -18.134     | 40.000         | QUASPEAK      | 100.000      | -48.000         |
| 4 |   | 144.000         | -10.654             | 31.600               | 20.946                 | -19.054     | 40.000         | QUASPEAK      | 100.000      | -47.000         |
| 5 |   | 227.800         | -12.183             | 28.300               | 16.118                 | -23.882     | 40.000         | QUASPEAK      | 100.000      | -27.000         |
| 6 |   | 250.000         | -10.388             | 30.000               | 19.612                 | -27.388     | 47.000         | QUASPEAK      | 100.000      | -47.000         |
| 7 |   | 500.000         | -1.909              | 26.400               | 24.491                 | -22.509     | 47.000         | QUASPEAK      | 290.000      | -12.000         |

**Note:**

1. All Readings below 1GHz are Quasi-Peak, above are performed with peak and/or average measurements as necessary.
2. " \* ", means this data is the worst emission level.
3. Measurement Level = Reading Level + Correct Factor

|                        |  |
|------------------------|--|
| Site : SITE7           | Time : 2018/10/29 - 17:09                    |
| Limit : CISPR_A_10M_QP | Margin : 6                                   |
| EUT : Network Camera   | Probe : Site7_VULB9168_10m_1804 - HORIZONTAL |
| Power : By PoE         | Note: Mode 2                                 |

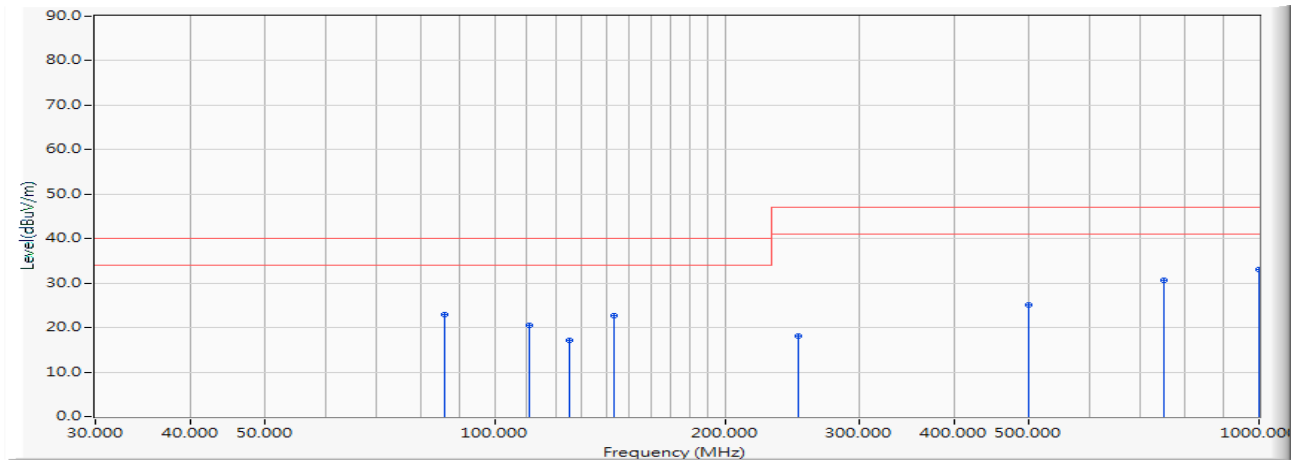

|   | Frequency (MHz) | Correct Factor (dB) | Reading Level (dBuV) | Measure Level (dBuV/m) | Margin (dB) | Limit (dBuV/m) | Detector Type | Ant Pos (cm) | Table Pos (deg) |
|---|-----------------|---------------------|----------------------|------------------------|-------------|----------------|---------------|--------------|-----------------|
| 1 | 86.040          | -16.387             | 39.300               | 22.913                 | -17.087     | 40.000         | QUASIPeAK     | 400.000      | 67.000          |
| 2 | 110.700         | -13.890             | 34.300               | 20.410                 | -19.590     | 40.000         | QUASIPeAK     | 400.000      | -47.000         |
| 3 | 125.000         | -12.407             | 29.600               | 17.194                 | -22.806     | 40.000         | QUASIPeAK     | 400.000      | -4.000          |
| 4 | 143.300         | -10.692             | 33.300               | 22.608                 | -17.392     | 40.000         | QUASIPeAK     | 400.000      | 62.000          |
| 5 | 250.000         | -10.388             | 28.500               | 18.112                 | -28.888     | 47.000         | QUASIPeAK     | 360.000      | 67.000          |
| 6 | 500.000         | -1.909              | 27.000               | 25.091                 | -21.909     | 47.000         | QUASIPeAK     | 200.000      | -134.000        |
| 7 | 750.000         | 4.566               | 26.000               | 30.565                 | -16.435     | 47.000         | QUASIPeAK     | 130.000      | -23.000         |
| 8 | * 1000.000      | 7.730               | 25.400               | 33.130                 | -13.870     | 47.000         | QUASIPeAK     | 100.000      | 114.000         |

**Note:**

1. All Readings below 1GHz are Quasi-Peak, above are performed with peak and/or average measurements as necessary.
2. " \* ", means this data is the worst emission level.
3. Measurement Level = Reading Level + Correct Factor

|                        |  |
|------------------------|--|
| Site : SITE7           | Time : 2018/10/29 - 17:09                  |
| Limit : CISPR_A_10M_QP | Margin : 6                                 |
| EUT : Network Camera   | Probe : Site7_VULB9168_10m_1804 - VERTICAL |
| Power : By PoE         | Note: Mode 2                               |

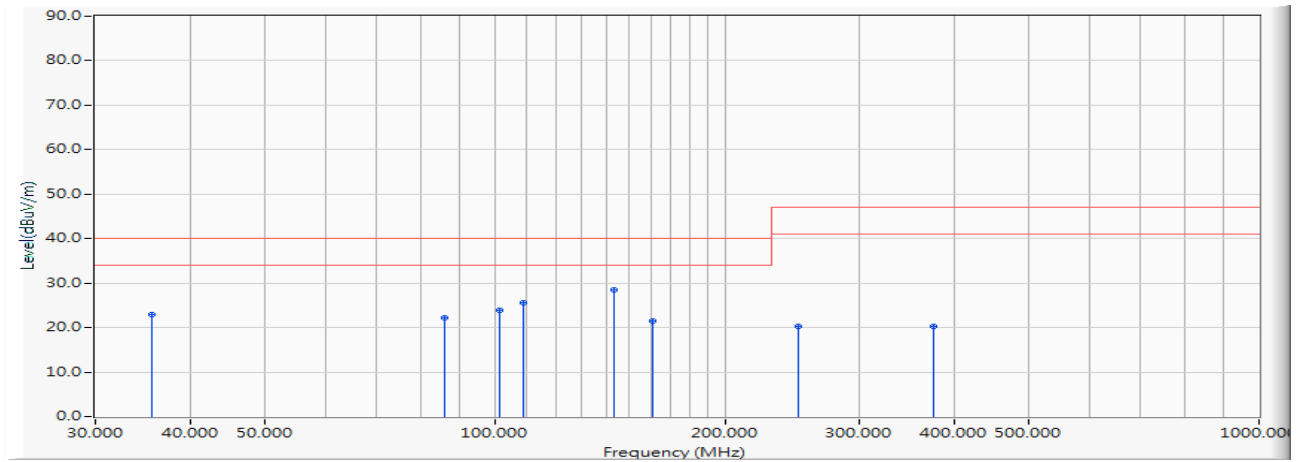

|   | Frequency (MHz) | Correct Factor (dB) | Reading Level (dBuV) | Measure Level (dBuV/m) | Margin (dB) | Limit (dBuV/m) | Detector Type | Ant Pos (cm) | Table Pos (deg) |
|---|-----------------|---------------------|----------------------|------------------------|-------------|----------------|---------------|--------------|-----------------|
| 1 | 35.600          | -12.663             | 35.600               | 22.937                 | -17.063     | 40.000         | QUASPEAK      | 100.000      | 96.000          |
| 2 | 86.080          | -16.392             | 38.600               | 22.209                 | -17.791     | 40.000         | QUASPEAK      | 100.000      | -4.000          |
| 3 | 101.200         | -15.326             | 39.200               | 23.874                 | -16.126     | 40.000         | QUASPEAK      | 100.000      | 108.000         |
| 4 | 108.800         | -14.152             | 39.800               | 25.648                 | -14.352     | 40.000         | QUASPEAK      | 100.000      | 62.000          |
| 5 | * 143.200       | -10.698             | 39.100               | 28.402                 | -11.598     | 40.000         | QUASPEAK      | 100.000      | 63.000          |
| 6 | 161.100         | -10.132             | 31.600               | 21.467                 | -18.533     | 40.000         | QUASPEAK      | 100.000      | -58.000         |
| 7 | 250.000         | -10.388             | 30.600               | 20.212                 | -26.788     | 47.000         | QUASPEAK      | 100.000      | -47.000         |
| 8 | 375.000         | -5.843              | 26.000               | 20.157                 | -26.843     | 47.000         | QUASPEAK      | 100.000      | 64.000          |

Note:

1. All Readings below 1GHz are Quasi-Peak, above are performed with peak and/or average measurements as necessary.
2. " \* ", means this data is the worst emission level.
3. Measurement Level = Reading Level + Correct Factor

|                           |                          |
|---------------------------|--------------------------|
| Site: CB7                 | Time: 2018/10/30 - 19:57 |
| Limit: VCCI_B_(Above_1G)  | Margin: 0                |
| Probe: CB7_Horn_3117_1808 | Polarity: Horizontal     |
| EUT : Network Camera      | Power: AC 100V/50Hz      |
| Note: Mode 1              |                          |

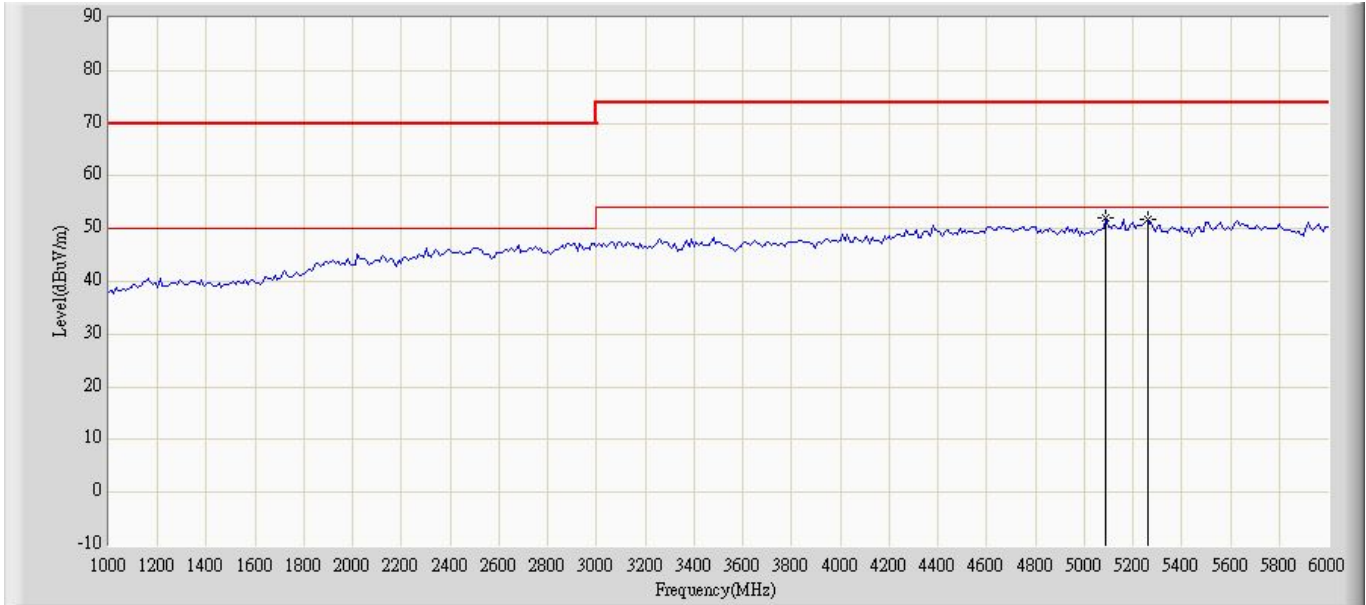

| No | Flag | Mark | Frequency (MHz) | Measure Level (dBuV/m) | Reading Level (dBuV) | Over Limit (dB) | Limit (dBuV/m) | Factor | Ant Pos (cm) | Table Pos (deg) | Type |
|----|------|------|-----------------|------------------------|----------------------|-----------------|----------------|--------|--------------|-----------------|------|
| 1  |      | *    | 5090.000        | 51.989                 | 35.814               | -22.011         | 74.000         | 16.175 | 100          | 99              | PK   |
| 2  |      |      | 5260.000        | 51.767                 | 35.317               | -22.233         | 74.000         | 16.450 | 100          | 51              | PK   |

Note:

1. All Readings below 1GHz are Quasi-Peak, above are performed with peak and/or average measurements as necessary.
2. " \* ", means this data is the worst emission level.
3. Measurement Level = Reading Level + Factor(Probe+Cable-Amp).

|                           |                          |
|---------------------------|--------------------------|
| Site: CB7                 | Time: 2018/10/30 - 20:00 |
| Limit: VCCI_B_(Above_1G)  | Margin: 0                |
| Probe: CB7_Horn_3117_1808 | Polarity: Vertical       |
| EUT : Network Camera      | Power: AC 100V/50Hz      |
| Note: Mode 1              |                          |

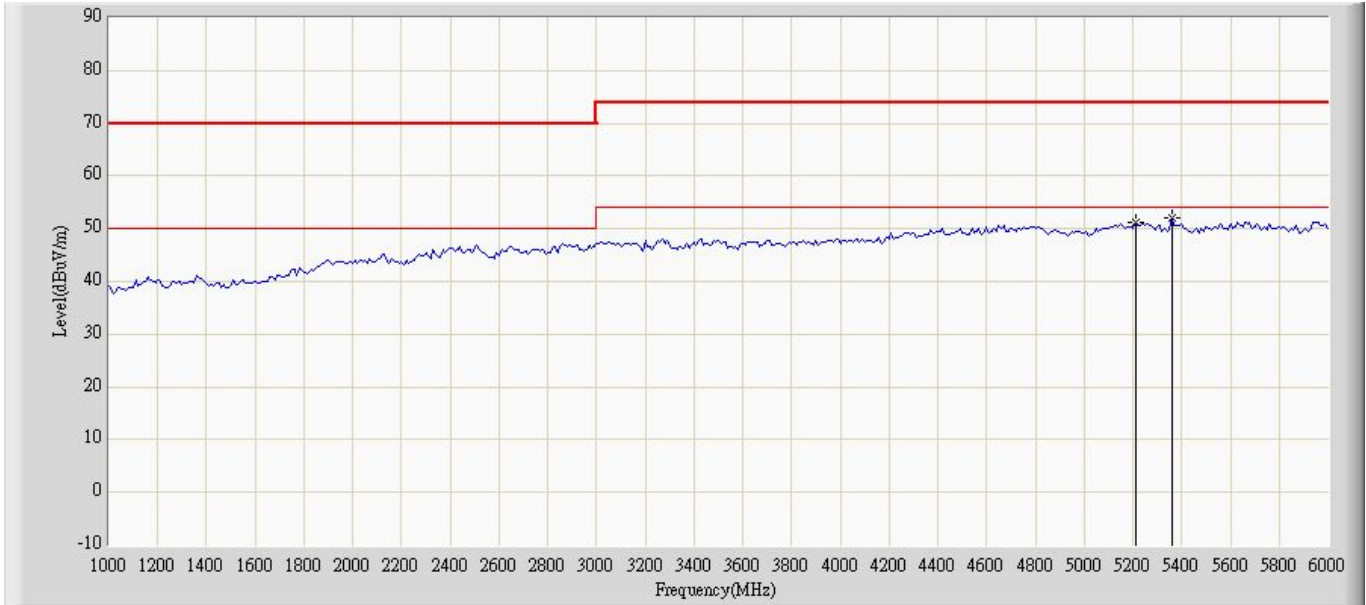

| No | Flag | Mark | Frequency (MHz) | Measure Level (dBuV/m) | Reading Level (dBuV) | Over Limit (dB) | Limit (dBuV/m) | Factor | Ant Pos (cm) | Table Pos (deg) | Type |
|----|------|------|-----------------|------------------------|----------------------|-----------------|----------------|--------|--------------|-----------------|------|
| 1  |      |      | 5210.000        | 51.276                 | 34.934               | -22.724         | 74.000         | 16.342 | 100          | 136             | PK   |
| 2  |      | *    | 5360.000        | 52.066                 | 35.364               | -21.934         | 74.000         | 16.702 | 100          | -56             | PK   |

Note:

1. All Readings below 1GHz are Quasi-Peak, above are performed with peak and/or average measurements as necessary.
2. " \* ", means this data is the worst emission level.
3. Measurement Level = Reading Level + Factor(Probe+Cable-Amp).

|                           |                          |
|---------------------------|--------------------------|
| Site: CB7                 | Time: 2018/10/30 - 20:29 |
| Limit: VCCI_B_(Above_1G)  | Margin: 0                |
| Probe: CB7_Horn_3117_1808 | Polarity: Horizontal     |
| EUT : Network Camera      | Power : By PoE           |
| Note: Mode 2              |                          |

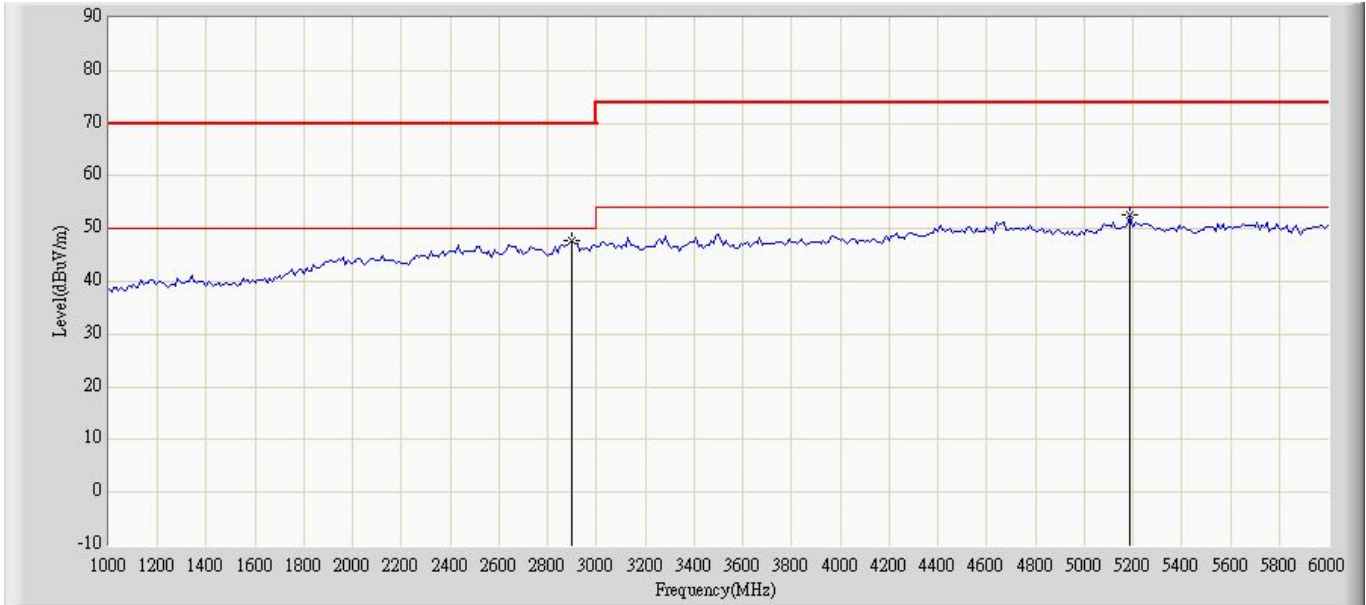

| No | Flag | Mark | Frequency (MHz) | Measure Level (dBuV/m) | Reading Level (dBuV) | Over Limit (dB) | Limit (dBuV/m) | Factor | Ant Pos (cm) | Table Pos (deg) | Type |
|----|------|------|-----------------|------------------------|----------------------|-----------------|----------------|--------|--------------|-----------------|------|
| 1  |      |      | 2900.000        | 47.849                 | 35.671               | -22.151         | 70.000         | 12.178 | 100          | -105            | PK   |
| 2  |      | *    | 5190.000        | 52.696                 | 36.407               | -21.304         | 74.000         | 16.289 | 100          | -155            | PK   |

Note:

1. All Readings below 1GHz are Quasi-Peak, above are performed with peak and/or average measurements as necessary.
2. " \* ", means this data is the worst emission level.
3. Measurement Level = Reading Level + Factor(Probe+Cable-Amp).

|                           |                          |
|---------------------------|--------------------------|
| Site: CB7                 | Time: 2018/10/30 - 20:25 |
| Limit: VCCI_B_(Above_1G)  | Margin: 0                |
| Probe: CB7_Horn_3117_1808 | Polarity: Vertical       |
| EUT : Network Camera      | Power : By PoE           |
| Note: Mode 2              |                          |

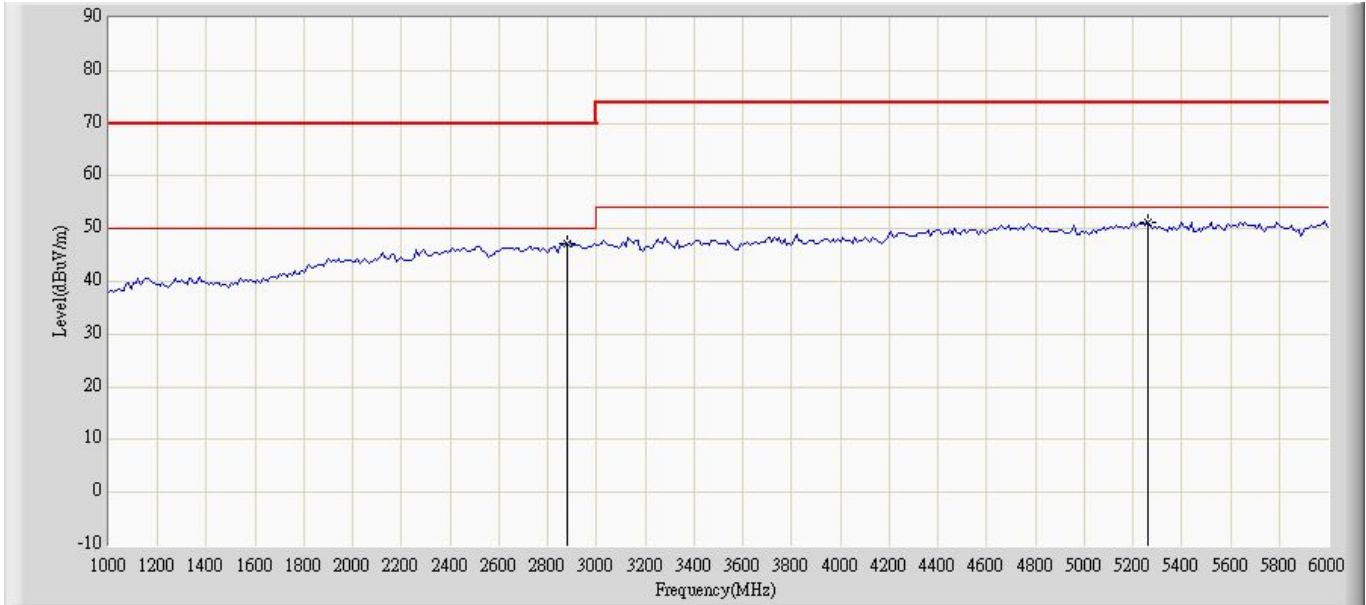

| No | Flag | Mark | Frequency (MHz) | Measure Level (dBuV/m) | Reading Level (dBuV) | Over Limit (dB) | Limit (dBuV/m) | Factor | Ant Pos (cm) | Table Pos (deg) | Type |
|----|------|------|-----------------|------------------------|----------------------|-----------------|----------------|--------|--------------|-----------------|------|
| 1  |      | *    | 2880.000        | 47.318                 | 35.194               | -22.682         | 70.000         | 12.124 | 100          | 74              | PK   |
| 2  |      |      | 5260.000        | 51.105                 | 34.655               | -22.895         | 74.000         | 16.450 | 100          | -84             | PK   |

Note:

1. All Readings below 1GHz are Quasi-Peak, above are performed with peak and/or average measurements as necessary.
2. " \* ", means this data is the worst emission level.
3. Measurement Level = Reading Level + Factor(Probe+Cable-Amp).

### 5.7. Test Photograph

Test Mode : Mode 1: IB9387-EH , DC

Description : Front View of Radiated Test



Test Mode : Mode 1: IB9387-EH , DC

Description : Back View of Radiated Test



Test Mode : Mode 1: IB9387-EH , DC

Description : Front View of High Frequency Radiated Test



Test Mode : Mode 2: IB9387-EH , PoE

Description : Front View of Radiated Test



Test Mode : Mode 2: IB9387-EH , PoE

Description : Back View of Radiated Test



Test Mode : Mode 2: IB9387-EH , PoE

Description : Back View of Radiated Test



**6. Attachment**

➤ **EUT Photograph**

(1) EUT Photo \_M/N: IB9387-EH



(2) EUT Photo \_M/N: IB9387-EH



(3) EUT Photo \_M/N: IB9387-EH

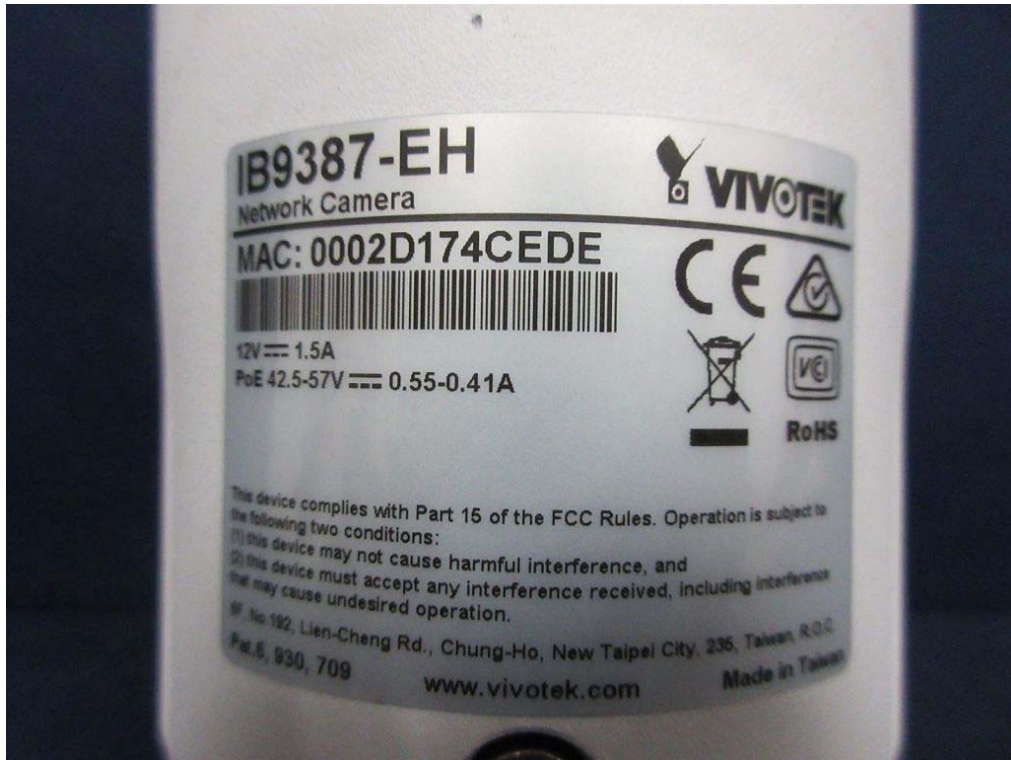

(4) EUT Photo \_M/N: IB9387-H



(5) EUT Photo \_M/N: IB9387-H



(6) EUT Photo \_M/N: IB9387-H

