



CE EMC Test Report

Issued date: Jan. 26, 2016

Project No.: 15Q120703

Product : Network Camera

Model : IP9181-HP

Applicant : VIVOTEK INC.

Address : 6F, No. 192, Lien-Cheng Rd., Chung-Ho, New Taipei City, 235,
Taiwan, R.O.C.

Report No: WD-EE-R-150163-00

According to

EN55022: 2010 +AC:2011, Class B

AS/NZS CISPR 22:2009 +A1:2010, Class B

CISPR 22: 2008 (Ed 6.0)

EN 61000-3-2: 2014

EN 61000-3-3: 2013

EN55024: 2010 (Ed 2.0)

IEC 61000-4-2: 2008 (Ed 2.0)

IEC 61000-4-3: 2010 (Ed 3.2)

IEC 61000-4-4: 2012 (Ed 3.0)

IEC 61000-4-5: 2014 (Ed 3.0)

IEC 61000-4-6: 2013 (Ed 4.0)

IEC 61000-4-8: 2009 (Ed 2.0)

IEC 61000-4-11: 2004 (Ed 2.0)

Technical Engineer : Toby Chung / Toby Chung

Authorized Signatory : Ken Huang / Ken Huang



Wendell Industrial Co., Ltd

Wendell Electronic Test Laboratory

Add: 6F/6F-1, No.188, Baoqiao Rd., Xindian Dist., New Taipei City 23145, Taiwan R.O.C.



Table of Contents

| | | |
|----------|---|-----------|
| 1 | Certification | 7 |
| 1.1 | Summary of Test Result..... | 8 |
| 2 | Test Configuration of Equipment Under Test | 9 |
| 2.1 | Test Facility..... | 9 |
| 2.2 | Measurement Uncertainty | 10 |
| 2.2.1 | Conducted Emission test..... | 10 |
| 2.2.2 | Conducted emission at telecom port test | 10 |
| 2.2.3 | Radiated Emission test..... | 10 |
| 2.2.4 | Harmonics Current Measurement..... | 10 |
| 2.2.5 | Voltage Fluctuation and Flicker Measurement..... | 11 |
| 2.2.6 | Immunity Test..... | 11 |
| 3 | Generation Information | 12 |
| 3.1 | Description of EUT..... | 12 |
| 3.2 | Description of Test Modes..... | 13 |
| 3.3 | EUT Operating Condition | 14 |
| 3.4 | Description of Support Unit | 15 |
| 3.5 | Configuration of System Under Test..... | 16 |
| 4 | Emission Test..... | 18 |
| 4.1 | Conducted Emission Measurement (Frequency Range 150 KHz-30MHz)..... | 18 |
| 4.1.1 | Limit of Conducted Emission Measurement | 18 |
| 4.1.2 | Test Instrument | 18 |
| 4.1.3 | Test Procedure..... | 19 |
| 4.1.4 | Deviation from Test Standard | 19 |
| 4.1.5 | Test Setup..... | 20 |
| 4.1.6 | Test Result | 21 |
| 4.1.7 | Photographs of Test Configuration | 25 |
| 4.2 | Conducted Emission at Telecommunication Ports Test | 27 |
| 4.2.1 | Limit of Conducted Emission at Telecommunication Ports Test..... | 27 |
| 4.2.2 | Test Instrument | 27 |
| 4.2.3 | Test Procedure..... | 28 |
| 4.2.4 | Deviation from Test Standard | 28 |
| 4.2.5 | Test Setup..... | 29 |
| 4.2.6 | Test Result | 30 |
| 4.2.7 | Photographs of Test Configuration | 39 |
| 4.3 | Radiated Emission Measurement | 42 |
| 4.3.1 | Limits of Radiated Emission Measurement..... | 42 |
| 4.3.2 | Test Instrument | 43 |
| 4.3.3 | Test Procedure..... | 44 |
| 4.3.4 | Deviation from Test Standard | 44 |
| 4.3.5 | Test Setup..... | 45 |
| 4.3.6 | Test Result | 46 |
| 4.3.7 | Photographs of Test Configuration | 58 |
| 4.4 | Harmonics Current Measurement..... | 64 |
| 4.4.1 | Limits of Harmonics Current Measurement | 64 |
| 4.4.2 | Test Instrument | 64 |
| 4.4.3 | Test Procedure..... | 65 |



4.4.4 Deviation from Test Standard 66

4.4.5 Test Setup..... 66

4.4.6 Test Result 67

4.4.7 Photographs of Test Configuration 68

4.5 Voltage Fluctuation and Flicker Measurement 69

4.5.1 Limit for Voltage Function and Flicker Measurement 69

4.5.2 Test Instrument 69

4.5.3 Test Procedure..... 69

4.5.4 Deviation from Test Standard 69

4.5.5 Test Setup..... 70

4.5.6 Test Result 71

4.5.7 Photographs of Test Configuration 72

5 Immunity Test 73

5.1 Standard Description 73

5.2 Performance Criteria 74

5.3 Electrostatic Discharge (ESD) 75

5.3.1 Test Specification..... 75

5.3.2 Test Instrument 75

5.3.3 Test Procedure..... 76

5.3.4 Deviation from Test Standard 77

5.3.5 Test Setup..... 77

5.3.6 Test Result 78

5.3.7 Photographs of Test Configuration 82

5.4 Radiated, Radio-frequency, Electromagnetic Field Immunity Test (RS) 84

5.4.1 Test Specification..... 84

5.4.2 Test Instrument 84

5.4.3 Test Procedure..... 85

5.4.4 Deviation from Test Standard 85

5.4.5 Test Setup..... 86

5.4.6 Test Result 87

5.4.7 Photographs of Test Configuration 88

5.5 Electrical Fast Transient /Burst Immunity Test (EFT) 97

5.5.1 Test Specification..... 97

5.5.2 Test Instrument 97

5.5.3 Test Procedure..... 98

5.5.4 Deviation from Test Standard 98

5.5.5 Test Setup..... 99

5.5.6 Test Result 100

5.5.7 Photographs of Test Configuration 101

5.6 Surge Immunity Test 104

5.6.1 Test Specification..... 104

5.6.2 Test Instrument 104

5.6.3 Test Procedure..... 105

5.6.4 Deviation from Test Standard 105

5.6.5 Test Setup..... 105

5.6.6 Test Result 106

5.6.7 Photographs of Test Configuration 107

5.7 Continuous Conducted Disturbances (CS) 108

5.7.1 Test Specification..... 108



| | | |
|------------|---|------------|
| 5.7.2 | Test Instrument | 108 |
| 5.7.3 | Test Procedure..... | 108 |
| 5.7.4 | Deviation from Test Standard | 109 |
| 5.7.5 | Test Setup..... | 109 |
| 5.7.6 | Test Result | 110 |
| 5.7.7 | Photographs of Test Configuration | 111 |
| 5.8 | Power Frequency Magnetic Field Immunity Test | 114 |
| 5.8.1 | Test Specification..... | 114 |
| 5.8.2 | Test Instrument | 114 |
| 5.8.3 | Test Setup..... | 115 |
| 5.8.4 | Test Procedure..... | 114 |
| 5.8.5 | Deviation from Test Standard | 114 |
| 5.8.6 | Test Result | 116 |
| 5.8.7 | Photographs of Test Configuration | 117 |
| 5.9 | Voltage Dips & Short Interruptions | 119 |
| 5.9.1 | Test Specification..... | 119 |
| 5.9.2 | Test Instrument | 119 |
| 5.9.3 | Test Procedure..... | 120 |
| 5.9.4 | Deviation from Test Standard | 120 |
| 5.9.5 | Test Setup..... | 120 |
| 5.9.6 | Test Result | 121 |
| 5.9.7 | Photographs of Test Configuration | 122 |



History of this test report

| Report No. | Issue date | Description |
|-------------------|---------------|---------------|
| WD-EE-R-150163-00 | Jan. 26, 2016 | Initial Issue |

Declaration

This report is for your exclusive use. Any copying or replication of this report to or for any other person or entity, or use of our name or trademark, is permitted only with our prior written permission. This report sets forth our findings solely with respect to the test samples identified herein. The results set forth in this report are not indicative or representative of the quality or characteristics of the lot from which a test sample was taken or any similar or identical product unless specifically and expressly noted. Our report includes all of the tests requested by you and the results thereof based upon the information that you provided to us.



History of supplementary report

| Report No. | Issue date | Description |
|-------------------|---------------|-----------------|
| WD-EE-R-150163-00 | Jan. 26, 2016 | Original report |

Declaration

This report is for your exclusive use. Any copying or replication of this report to or for any other person or entity, or use of our name or trademark, is permitted only with our prior written permission. This report sets forth our findings solely with respect to the test samples identified herein. The results set forth in this report are not indicative or representative of the quality or characteristics of the lot from which a test sample was taken or any similar or identical product unless specifically and expressly noted. Our report includes all of the tests requested by you and the results thereof based upon the information that you provided to us.



1 Certification

Product: Network Camera
Brand Name: VIVOTEK
Model No: IP9181-HP
Applicant: VIVOTEK INC.
Tested: Dec. 18 ~ Dec. 24, 2015
Standard: **EN 55022: 2010 +AC: 2011, Class B**
AS/NZS CISPR 22:2009 +A1:2010, Class B
CISPR 22: 2008 (Ed 6.0)
EN 61000-3-2: 2014
EN 61000-3-3: 2013
EN 55024: 2010
IEC 61000-4-2: 2008
IEC 61000-4-3: 2010
IEC 61000-4-4: 2012
IEC 61000-4-5: 2014
IEC 61000-4-6: 2013
IEC 61000-4-8: 2009
IEC 61000-4-11: 2004

The above equipment (Model: IP9181-HP) has been tested by **Wendell Electrical Test Laboratory**, and found compliance with the requirement of the above standards. The test record, data evaluation and Equipment Under Test (EUT) configurations represented herein are true and accurate accounts of the measurements of the sample's EMC characteristics under the conditions specified in this report.



1.1 Summary of Test Result

The EUT has been tested according to the following specifications:

| Emission | | | | |
|--------------|---|---------|--------|---|
| Standard | Test Item | Limit | Result | Remark |
| EN 55022 | Conducted disturbance at mains terminals | Class B | Pass | Meets the requirements |
| CISPR 22 | Conducted disturbance at telecommunication ports test | Class B | Pass | Meets the requirements |
| | Radiated disturbance | Class B | Pass | Meets the requirements |
| EN 61000-3-2 | Harmonic current emissions | Class A | Pass | The power consumption of EUT is less than 75W and no limits apply |
| EN 61000-3-3 | Voltage fluctuations and flicker | - | Pass | Meets the requirements |

| Immunity | | | |
|----------------|--|--------|--|
| Standard | Test Item | Result | Remark |
| IEC 61000-4-2 | Electrostatic discharges (ESD) | Pass | Meets the requirements of Performance Criterion B |
| IEC 61000-4-3 | Continuous radiated disturbances (RS) | Pass | Meets the requirements of Performance Criterion A |
| IEC 61000-4-4 | Electrical fast transients (EFT) | Pass | Meets the requirements of Performance Criterion A |
| IEC 61000-4-5 | Surges | Pass | Meets the requirements of Performance Criterion A |
| IEC 61000-4-6 | Continuous conducted disturbances (CS) | Pass | Meets the requirements of Performance Criterion A |
| IEC 61000-4-8 | Power-frequency magnetic fields (PFMF) | Pass | Meets the requirements of Performance Criterion A |
| IEC 61000-4-11 | Voltage dips and interruptions | Pass | Meets the requirements of Voltage Dips: ✧ >95% reduction – Performance Criterion A ✧ 30% reduction - Performance Criterion A Voltage Interruptions: ✧ >95% reduction - Performance Criterion B |

Note: Test record contained in the referenced test report relate only to the EUT sample and test item.

2 Test Configuration of Equipment Under Test

2.1 Test Facility

Conducted disturbance at mains terminals, Conducted disturbance at telecommunication ports, Harmonics, Flicker and Immunity Tests

W01: Add: 6F/6F-1, No.188, Baoqiao Rd., Xindian Dist., New Taipei City 23145, Taiwan
R.O.C.

Radiated emission Test (OATS)

W03: Land No. 0295-0006, Dakeng Small Section, New Small Keelung Section, Sanzhi Dist.,
New Taipei City 252, Taiwan (R.O.C.)

ACCREDITATIONS

The laboratories are accredited and approved by the TAF according to ISO/IEC 17025.

2.2 Measurement Uncertainty

The measurement instrumentation uncertainty consideration contained in CISPR 16-4-2.

This uncertainty represents an expanded uncertainty expressed at approximately the 95% confidence level using a coverage factor of $k=2$.

2.2.1 Conducted Emission test

| Test Site | Measurement Freq. Range | dB (U_{cispr}) | Note |
|-----------|-------------------------|--------------------|------|
| W01 | 150 kHz ~ 30 MHz | 3.19 | N/A |

2.2.2 Conducted emission at telecom port test

| Test Site | Measurement Freq. Range | dB (U_{cispr}) | Note |
|-----------|-------------------------|--------------------|------|
| W01 | 150 kHz ~ 30 MHz | 3.16 | N/A |

2.2.3 Radiated Emission test

| Test Site | Measurement Freq. Range | Ant | dB (U_{cispr}) | Note |
|-----------|-------------------------|-----|--------------------|------|
| W03 | 30 MHz ~ 200 MHz | V | 4.29 | N/A |
| | 30 MHz ~ 200 MHz | H | 3.35 | N/A |
| | 200 MHz ~ 1000 MHz | V | 3.87 | N/A |
| | 200 MHz ~ 1000 MHz | H | 3.48 | N/A |
| | 1 GHz ~ 3 GHz | V | 4.47 | N/A |
| | 1 GHz ~ 3 GHz | H | 4.44 | N/A |
| | 3 GHz ~ 6 GHz | V | 4.86 | N/A |
| | 3 GHz ~ 6 GHz | H | 4.47 | N/A |

2.2.4 Harmonics Current Measurement

| Test Site | Expanded Uncertainty | |
|-----------|----------------------|---------|
| W01 | Voltage | 3.96 V |
| | Current | 1.18 mA |
| | Power | 0.15 Hz |

2.2.5 Voltage Fluctuation and Flicker Measurement

| Test Site | Expanded Uncertainty | |
|-----------|----------------------|---------|
| W01 | d_c, d_{max} | 11.56 % |
| | P_{st}, P_{lt} | 5.77 % |

2.2.6 Immunity Test

| Test Site | Item | Expanded Uncertainty | | Note |
|-----------|--|-------------------------|--------|---------------------|
| W01 | Electrostatic Discharge (ESD) | Voltage | 0.05% | N/A |
| | | Timing | 5.6% | |
| | Continuous radiated disturbances (RS) | 80MHz – 2.5GHz | 3.0dB | 80MHz - 1GHz, k=2 |
| | Electrical fast transients (EFT) | Voltage | 8.5% | N/A |
| | | Timing | 4.4% | |
| | Surges | Voltage | 3.9% | N/A |
| | | Current | 2.9% | |
| | | Time | 3.7% | |
| | Continuous conducted disturbances (CS) | CDN | 1.80dB | 150KHz – 80MHz, k=2 |
| | | EM Clamp | 3.75dB | |
| | Power-frequency magnetic fields (PFMF) | Magnetic Field Strength | 1.0% | N/A |
| | Voltage dips and interruptions | Voltage | 3.8% | N/A |
| | | Current | 2.4% | |
| | | Time | 2.0% | |

3 Generation Information

3.1 Description of EUT

| | |
|----------------------------|--|
| Product | Network Camera |
| Brand | VIVOTEK |
| Model No. | IP9181-HP |
| Applicant | VIVOTEK INC. |
| EUT Power Rating | 12Vdc (from adapter) or 24Vdc (from adapter) or 48Vdc (from POE) |
| Model Differences | N/A |
| Operating System | N/A |
| Data Cable Supplied | N/A |
| Accessory Device | N/A |
| I/O Port | Please refer to the User's Manual |

Note:

1. The EUT's highest operating frequency is 1600MHz. Therefore the radiated emission is tested up to 6Hz.

3.2 Description of Test Modes

Test results are presented in the report as below.

| Test Result | Test Condition |
|---|--|
| Conducted emission test | |
| A | DC Adapter mode, Adapter 1 |
| B | AC Adapter mode, Adapter 2 |
| Conducted emission test at telecom port test | |
| A | LAN (10Mbps/100Mbps/1Gbps), DC Adapter mode, Adapter 1 |
| B | LAN (10Mbps/100Mbps/1Gbps), AC Adapter mode, Adapter 2 |
| C | LAN (10Mbps/100Mbps/1Gbps), POE mode |
| Radiated emission 30MHz ~ 1GHz test | |
| A | DC Adapter mode, Adapter 1 |
| B | AC Adapter mode, Adapter 2 |
| C | POE mode |
| Radiated emission above 1GHZ test | |
| A | DC Adapter mode, Adapter 1 |
| B | AC Adapter mode, Adapter 2 |
| C | POE mode |
| Harmonics, Flicker and Immunity tests | |
| A | DC Adapter mode, Adapter 1 |
| B | AC Adapter mode, Adapter 2 |
| C | POE mode |

3.3 EUT Operating Condition

Adapter mode

- a. Placed the EUT on the test table.
- b. Prepared server PC to act as a communication partner and placed it outside of testing area.
- c. The EUT was connected to the server PC with LAN cable.
- d. The EUT write data with micro SD card.
- e. The microphone sent voice signal to EUT
- f. The EUT sent voice signal to earphone.
- g. The server PC show EUT's image on browser.
- h. The communication partner sent data to EUT by command "PING" via LAN.

POE mode

- a. Placed the EUT on the test table.
- b. Prepared POE injector and server PC to act as a communication partner and placed it outside of testing area.
- c. The EUT was connected to the POE injector and server PC with LAN cables.
- d. The EUT write data with micro SD card.
- e. The microphone sent voice signal to EUT
- f. The EUT sent voice signal to earphone.
- g. The server PC show EUT's image on browser.
- h. The communication partner sent data to EUT by command "PING" via LAN.



3.4 Description of Support Unit

The EUT has been conducted testing with other necessary accessories or support units.

| Item | Equipment | Brand | Model No. | Serial No. | FCC ID | Data Cable | Power Cord | Remark |
|------|-----------------------|------------|-----------------|------------|------------------|--|---|--------------------|
| 1 | Earphone & Microphone | E-books | E-EPA038 | N/A | N/A | 1.9m non-shielded cable | N/A | - |
| 2 | Micro SD Card (16GB) | SanDisk | N/A | N/A | N/A | N/A | N/A | - |
| 3 | Adapter | OEM | ADS18B-B 120150 | N/A | N/A | N/A | 1.5m non-shielded cable | Supplied by client |
| 4 | Adapter | AQUALITIES | MTA572415 | N/A | N/A | N/A | Input: 2.1m non-shielded cable Output 1.75m non-shielded cable | Supplied by client |
| 5 | POE Injector | GeoVision | GV-481 | N/A | N/A | 20m non-shielded RJ45 cable | - | - |
| 6 | Server PC | DELL | OPTIPLEX 380 | 2C6742S | FCC DoC Approved | 20m non-shielded RJ45 cable (for adapter mode), 1m non-shielded RJ45 cable (for POE mode) | 1.8m non-shielded cable | - |

- Note:**
1. The core(s) is(are) originally attached to the cable(s).
 2. Item 6 acted as communication partners to transfer data.
 3. Item 2 was inserted into EUT during the test.
 4. The EUT uses the follow adapters and POE:

| Adapter 1 (Support Unit) | |
|--------------------------|-------------------------|
| Brand | OEM |
| Model | ADS18B-B 120150 |
| Input Power | 100-240Vac, 0.5A |
| Output Power | 12Vdc, 1.5A |
| Power line | 1.5m non-shielded cable |

| Adapter 2 (Support Unit) | |
|--------------------------|---|
| Brand | AQUALITIES |
| Model | MTA572415 |
| Input Power | 230Vac |
| Output Power | 24Vac, 1.5A |
| Power line | Input: 2.1m non-shielded cable Output 1.75m non-shielded cable |

| POE Injector (Support Unit) | |
|-----------------------------|----------------|
| Brand | GeoVision |
| Model | GV-481 |
| Input Power | 100-240Vac, 2A |
| Output Power | 48Vdc, 1A |

3.5 Configuration of System Under Test

AC Adapter mode and DC Adapter mode

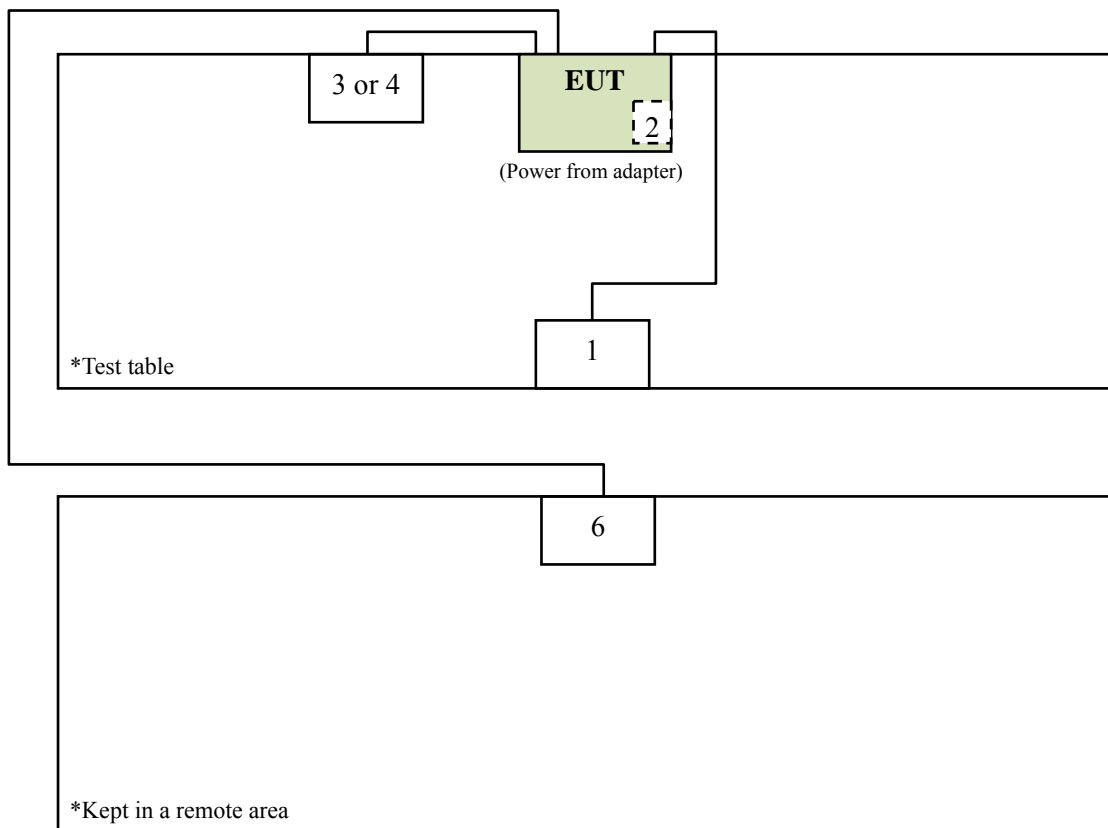

POE mode

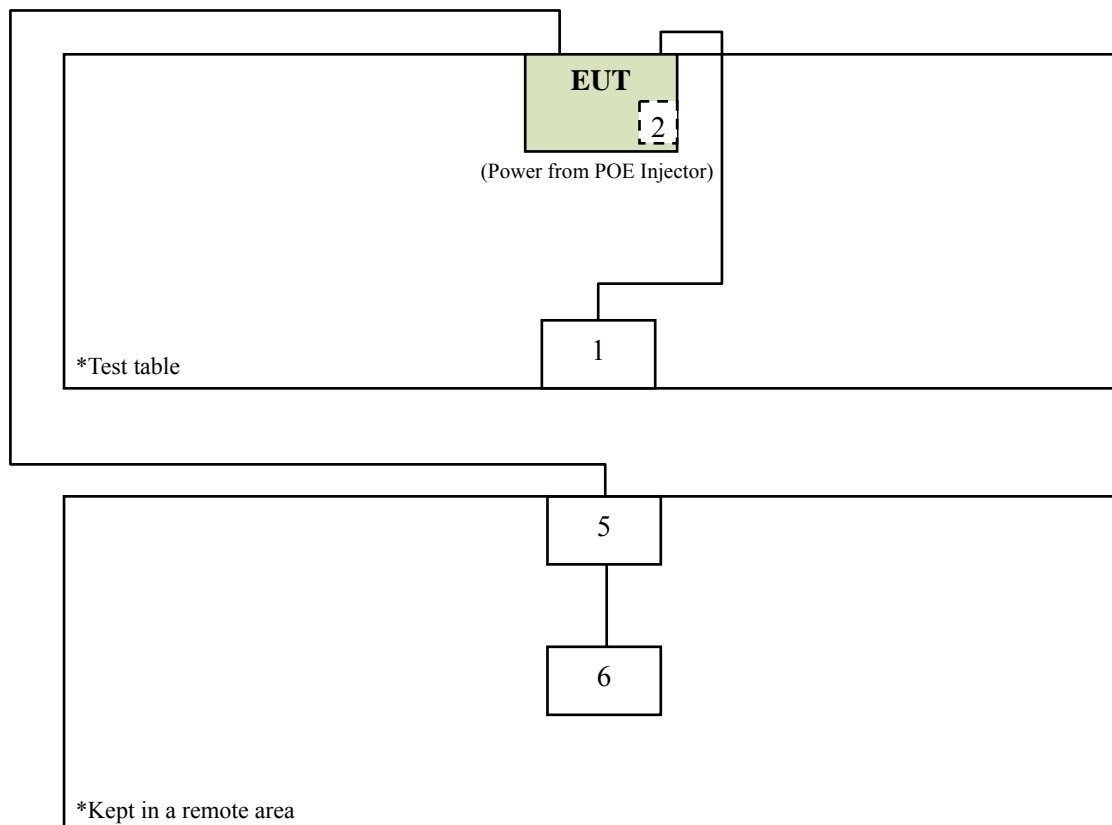

4 Emission Test

4.1 Conducted Emission Measurement (Frequency Range 150 KHz-30MHz)

4.1.1 Limit of Conducted Emission Measurement

| Frequency (MHz) | Class A (dBuV) | | Class B (dBuV) | |
|-----------------|----------------|---------|----------------|----------|
| | Quasi-peak | Average | Quasi-peak | Average |
| 0.15 to 0.5 | 79 | 66 | 66 to 56 | 56 to 46 |
| 0.50 to 5.0 | 73 | 60 | 56 | 46 |
| 5.0 to 30.0 | 73 | 60 | 60 | 50 |

- Note:**
1. The lower limit shall apply at the transition frequencies.
 2. The limit decreases in line with the logarithm of the frequency in the range of 0.15 to 0.50 MHz.
 3. Detector function in the form: PK = Peak, QP = Quasi Peak, AV = Average
 4. The test result calculated as following:
 Measurement Value = Reading Level + Correct Factor
 Correction Factor = Insertion loss of LISN + Cable loss
 Margin Level = Measurement Value – Limit Value

4.1.2 Test Instrument

| Item | Equipment | Manufacturer | Model | Meter No. | Calibration Date |
|------|----------------------|--------------|-------------|------------|------------------------|
| 1 | TWO-LINE V-NETWORK | R&S | ENV216 | CT-1-025-1 | Mar. 27, 2015 |
| 2 | EMI Test Receiver | R&S | ESCI | CT-01-024 | Apr. 01, 2015 |
| 3 | TWO-LINE V-NETWORK | R&S | ENV216 | CT-1-025-2 | Mar. 27, 2015 |
| 4 | Test Cable | HANRUIN | 5D-FB | CT-1-069-2 | Aug. 05, 2015 |
| 5 | 50ohm Termination | N/A | N/A | CT-1-065-1 | Mar. 30, 2015 |
| 6 | Measurement Software | EZ-EMC | Ver: FA-03A | CT-3-012 | No calibration request |

- Note:** 1. The calibration interval of the above test instruments is 12 months.

4.1.3 Test Procedure

- a. The EUT was placed 0.8 meter height wooden table from the horizontal ground plane with EUT being connected to power source through a line impedance stabilization network (LISN). The LISN at least be 80 cm from nearest chassis of EUT.
- b. The line impedance stabilization network (LISN) provides 50 ohm/50uH of coupling impedance for the measuring instrument. All other support equipments powered from additional LISN(s).
- c. Interrelating cables that hang closer than 40 cm to the ground plane shall be folded back and forth in the center forming a bundle. All I/O cables were positioned to simulate typical usage.
- d. All I/O cables that are not connected to a peripheral shall be bundle in the center. The end of the cable may be terminated, if required, using the correct terminating impedance. The overall length shall not exceed 1 m.
- e. The EMI test receiver connected to LISN powering the EUT. The actual test configuration, please refer to EUT test photos.
- f. The receiver scanned from 150kHz to 30MHz for emissions in each of test modes. A scan was taken on both power lines, Line and Neutral, recording at least six highest emissions.
- g. The EUT and cable configuration of the above highest emission levels were recorded. The test data of the worst case was recorded.

4.1.4 Deviation from Test Standard

No deviation

4.1.5 Test Setup

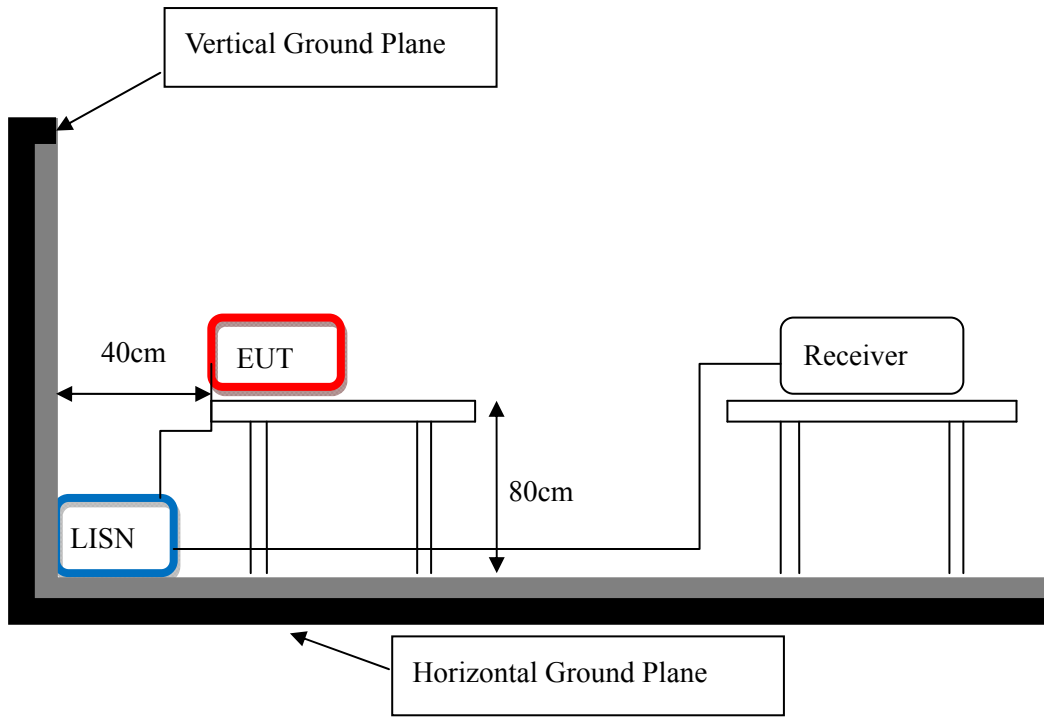

Note: Please refer to 4.1.7 for the actual test configuration.



4.1.6 Test Result

| | | | |
|---------------------------------|----------------|------------------------|-------------|
| Test Voltage | 230Vac, 50Hz | Frequency Range | 0.15-30 MHz |
| Environmental Conditions | 24.5°C, 56% RH | 6dB Bandwidth | 9 kHz |
| Test Date | 2015/12/18 | Phase | L |
| Tested by | Guanwei Liao | Test Mode | A |

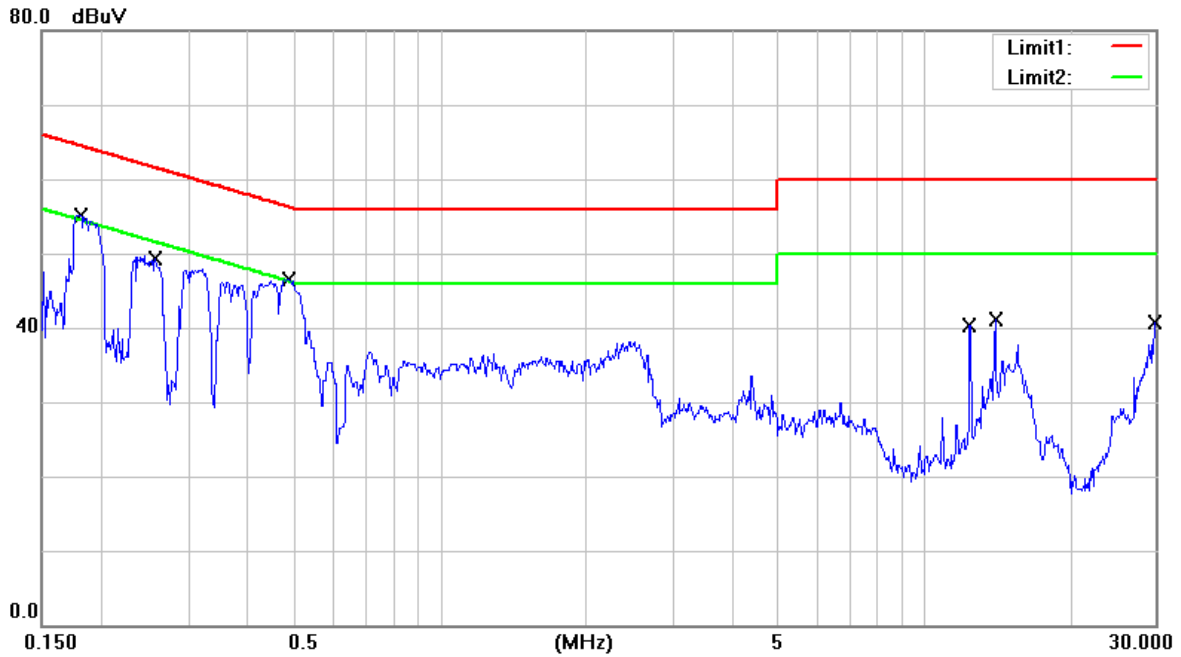

| No. | Frequency (MHz) | Reading Level (dBuV) | Correct Factor (dB) | Measurement (dBuV) | Limit (dBuV) | Margin (dB) | Detector |
|-----|-----------------|----------------------|---------------------|--------------------|--------------|-------------|----------|
| 1 | 0.1804 | 41.24 | 9.66 | 50.90 | 64.46 | -13.56 | QP |
| 2 | 0.1804 | 28.71 | 9.66 | 38.37 | 54.46 | -16.09 | AVG |
| 3 | 0.2567 | 33.76 | 9.66 | 43.42 | 61.53 | -18.11 | QP |
| 4 | 0.2567 | 22.78 | 9.66 | 32.44 | 51.53 | -19.09 | AVG |
| 5 | 0.4843 | 34.33 | 9.67 | 44.00 | 56.26 | -12.26 | QP |
| 6 | 0.4843 | 22.56 | 9.67 | 32.23 | 46.26 | -14.03 | AVG |
| 7 | 12.4000 | 20.52 | 9.85 | 30.37 | 60.00 | -29.63 | QP |
| 8 | 12.4000 | 15.08 | 9.85 | 24.93 | 50.00 | -25.07 | AVG |
| 9 | 13.9500 | 23.66 | 9.87 | 33.53 | 60.00 | -26.47 | QP |
| 10 | 13.9500 | 19.26 | 9.87 | 29.13 | 50.00 | -20.87 | AVG |
| 11 | 29.8500 | 15.00 | 9.83 | 24.83 | 60.00 | -35.17 | QP |
| 12 | 29.8500 | 9.16 | 9.83 | 18.99 | 50.00 | -31.01 | AVG |

Remark: 1. QP = Quasi Peak, AVG = Average
 2. Correction Factor = Insertion loss of LISN + Cable loss
 3. Measurement Value = Reading Level + Correct Factor
 4. Margin Level = Measurement Value - Limit Value



| | | | |
|---------------------------------|----------------|------------------------|-------------|
| Test Voltage | 230Vac, 50Hz | Frequency Range | 0.15-30 MHz |
| Environmental Conditions | 24.5°C, 56% RH | 6dB Bandwidth | 9 kHz |
| Test Date | 2015/12/18 | Phase | N |
| Tested by | Guanwei Liao | Test Mode | A |



| No. | Frequency (MHz) | Reading Level (dBuV) | Correct Factor (dB) | Measurement (dBuV) | Limit (dBuV) | Margin (dB) | Detector |
|-----|-----------------|----------------------|---------------------|--------------------|--------------|-------------|----------|
| 1 | 0.1759 | 38.60 | 9.64 | 48.24 | 64.67 | -16.43 | QP |
| 2 | 0.1759 | 22.33 | 9.64 | 31.97 | 54.67 | -22.70 | AVG |
| 3 | 0.2424 | 32.26 | 9.64 | 41.90 | 62.01 | -20.11 | QP |
| 4 | 0.2424 | 19.54 | 9.64 | 29.18 | 52.01 | -22.83 | AVG |
| 5 | 0.4787 | 32.44 | 9.65 | 42.09 | 56.36 | -14.27 | QP |
| 6 | 0.4787 | 20.64 | 9.65 | 30.29 | 46.36 | -16.07 | AVG |
| 7 | 2.6105 | 23.19 | 9.69 | 32.88 | 56.00 | -23.12 | QP |
| 8 | 2.6105 | 15.82 | 9.69 | 25.51 | 46.00 | -20.49 | AVG |
| 9 | 12.4000 | 27.65 | 9.86 | 37.51 | 60.00 | -22.49 | QP |
| 10 | 12.4000 | 23.27 | 9.86 | 33.13 | 50.00 | -16.87 | AVG |
| 11 | 13.9500 | 31.20 | 9.88 | 41.08 | 60.00 | -18.92 | QP |
| 12 | 13.9500 | 28.78 | 9.88 | 38.66 | 50.00 | -11.34 | AVG |

Remark:

1. QP = Quasi Peak, AVG = Average
2. Correction Factor = Insertion loss of LISN + Cable loss
3. Measurement Value = Reading Level + Correct Factor
4. Margin Level = Measurement Value - Limit Value



| | | | |
|---------------------------------|----------------|------------------------|-------------|
| Test Voltage | 230Vac, 50Hz | Frequency Range | 0.15-30 MHz |
| Environmental Conditions | 24.5°C, 56% RH | 6dB Bandwidth | 9 kHz |
| Test Date | 2015/12/18 | Phase | L |
| Tested by | Guanwei Liao | Test Mode | B |

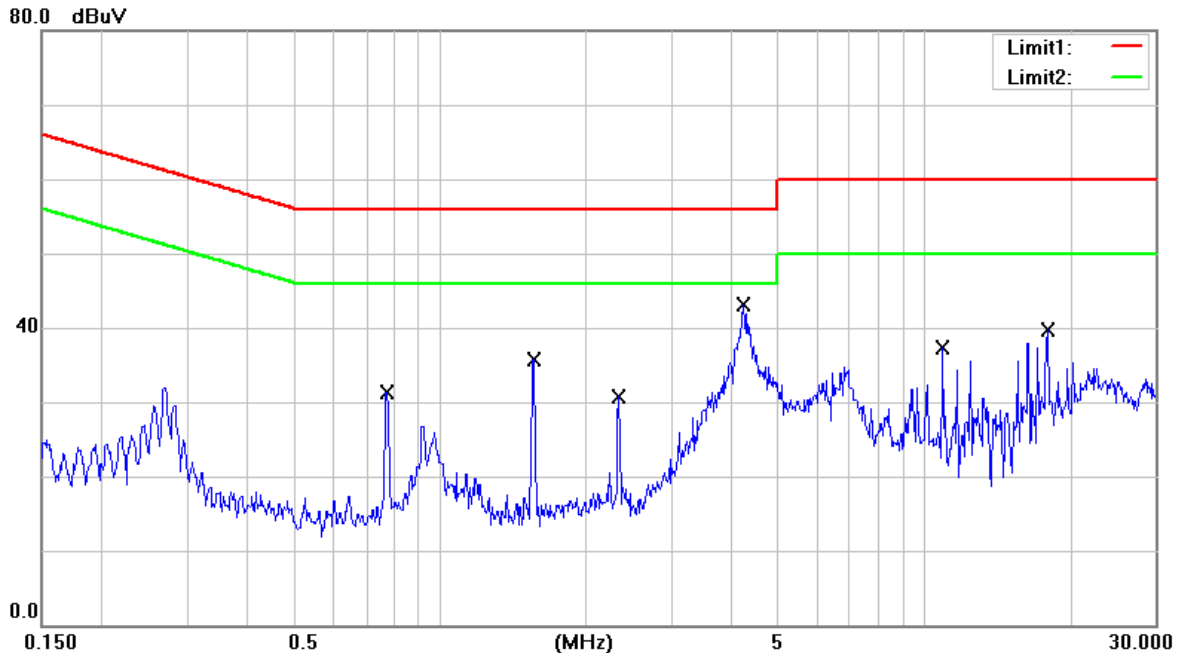

| No. | Frequency (MHz) | Reading Level (dBuV) | Correct Factor (dB) | Measurement (dBuV) | Limit (dBuV) | Margin (dB) | Detector |
|-----|-----------------|----------------------|---------------------|--------------------|--------------|-------------|----------|
| 1 | 0.7745 | 18.57 | 9.68 | 28.25 | 56.00 | -27.75 | QP |
| 2 | 0.7745 | 9.26 | 9.68 | 18.94 | 46.00 | -27.06 | AVG |
| 3 | 1.5530 | 26.65 | 9.70 | 36.35 | 56.00 | -19.65 | QP |
| 4 | 1.5530 | 15.74 | 9.70 | 25.44 | 46.00 | -20.56 | AVG |
| 5 | 2.3270 | 17.85 | 9.71 | 27.56 | 56.00 | -28.44 | QP |
| 6 | 2.3270 | 9.34 | 9.71 | 19.05 | 46.00 | -26.95 | AVG |
| 7 | 4.2215 | 26.88 | 9.73 | 36.61 | 56.00 | -19.39 | QP |
| 8 | 4.2215 | 14.81 | 9.73 | 24.54 | 46.00 | -21.46 | AVG |
| 9 | 10.8750 | 27.98 | 9.84 | 37.82 | 60.00 | -22.18 | QP |
| 10 | 10.8750 | 17.87 | 9.84 | 27.71 | 50.00 | -22.29 | AVG |
| 11 | 17.8750 | 19.27 | 9.90 | 29.17 | 60.00 | -30.83 | QP |
| 12 | 17.8750 | 9.49 | 9.90 | 19.39 | 50.00 | -30.61 | AVG |

Remark: 1. QP = Quasi Peak, AVG = Average
 2. Correction Factor = Insertion loss of LISN + Cable loss
 3. Measurement Value = Reading Level + Correct Factor
 4. Margin Level = Measurement Value - Limit Value



| | | | |
|---------------------------------|----------------|------------------------|-------------|
| Test Voltage | 230Vac, 50Hz | Frequency Range | 0.15-30 MHz |
| Environmental Conditions | 24.5°C, 56% RH | 6dB Bandwidth | 9 kHz |
| Test Date | 2015/12/18 | Phase | N |
| Tested by | Guanwei Liao | Test Mode | B |

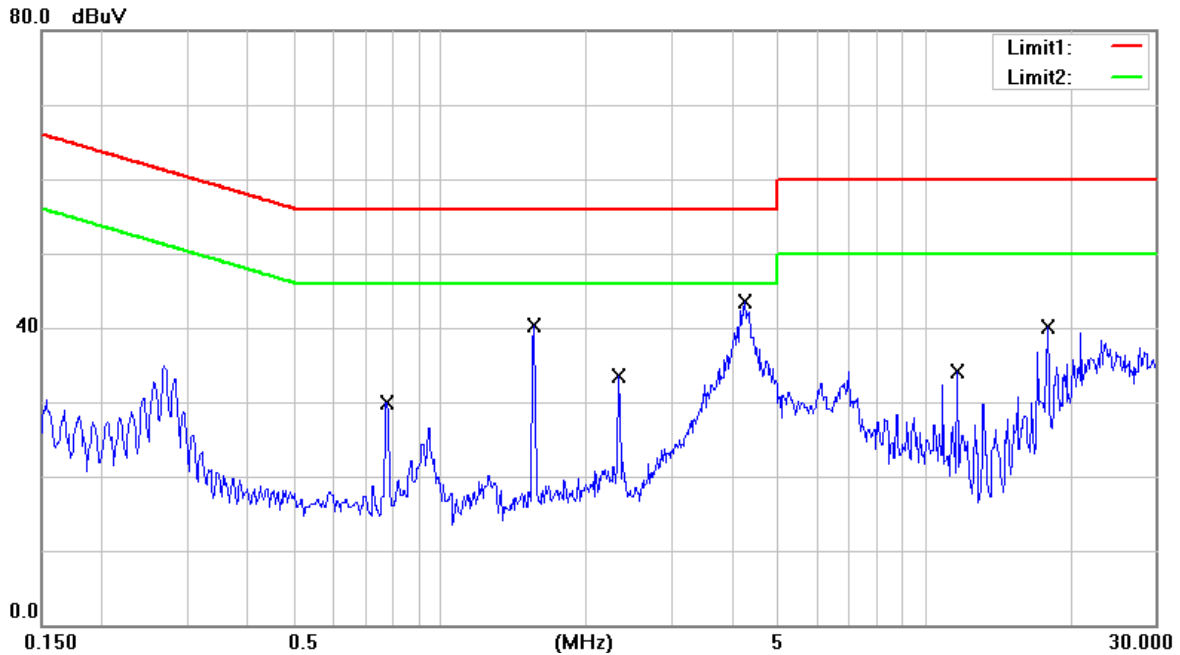

| No. | Frequency (MHz) | Reading Level (dBuV) | Correct Factor (dB) | Measurement (dBuV) | Limit (dBuV) | Margin (dB) | Detector |
|-----|-----------------|----------------------|---------------------|--------------------|--------------|-------------|----------|
| 1 | 0.7745 | 16.02 | 9.66 | 25.68 | 56.00 | -30.32 | QP |
| 2 | 0.7745 | 6.51 | 9.66 | 16.17 | 46.00 | -29.83 | AVG |
| 3 | 1.5575 | 26.38 | 9.68 | 36.06 | 56.00 | -19.94 | QP |
| 4 | 1.5575 | 12.08 | 9.68 | 21.76 | 46.00 | -24.24 | AVG |
| 5 | 2.3315 | 21.37 | 9.69 | 31.06 | 56.00 | -24.94 | QP |
| 6 | 2.3315 | 11.24 | 9.69 | 20.93 | 46.00 | -25.07 | AVG |
| 7 | 4.2395 | 27.31 | 9.71 | 37.02 | 56.00 | -18.98 | QP |
| 8 | 4.2395 | 15.73 | 9.71 | 25.44 | 46.00 | -20.56 | AVG |
| 9 | 11.6500 | 20.68 | 9.85 | 30.53 | 60.00 | -29.47 | QP |
| 10 | 11.6500 | 11.79 | 9.85 | 21.64 | 50.00 | -28.36 | AVG |
| 11 | 17.8750 | 30.29 | 9.92 | 40.21 | 60.00 | -19.79 | QP |
| 12 | 17.8750 | 17.10 | 9.92 | 27.02 | 50.00 | -22.98 | AVG |

Remark: 1. QP = Quasi Peak, AVG = Average
2. Correction Factor = Insertion loss of LISN + Cable loss
3. Measurement Value = Reading Level + Correct Factor
4. Margin Level = Measurement Value - Limit Value

4.1.7 Photographs of Test Configuration

Test mode A



Test mode B



4.2 Conducted Emission at Telecommunication Ports Test

4.2.1 Limit of Conducted Emission at Telecommunication Ports Test

Class A equipment

| Frequency (MHz) | Voltage limits dB (uV) | |
|-----------------|------------------------|----------|
| | Quasi-peak | Average |
| 0.15 to 0.5 | 97 to 87 | 84 to 74 |
| 0.5 to 30 | 87 | 74 |

Note: The limits decrease linearly with the logarithm of the frequency in the range 0.15 MHz to 0.5 MHz.

Class B equipment

| Frequency (MHz) | Voltage limits dB (uV) | |
|-----------------|------------------------|----------|
| | Quasi-peak | Average |
| 0.15 to 0.5 | 84 to 74 | 74 to 64 |
| 0.5 to 30 | 74 | 64 |

- Note:**
- The lower limit shall apply at the transition frequencies.
 - The limit decreases in line with the logarithm of the frequency in the range of 0.15 to 0.50 MHz.
 - Detector function in the form: PK = Peak, QP = Quasi Peak, AV = Average
 - The test result calculated as following:
 Measurement Value = Reading Level + Correct Factor
 Correction Factor = Insertion loss of ISN + Cable loss
 Margin Level = Measurement Value – Limit Value

4.2.2 Test Instrument

| Item | Equipment | Manufacturer | Model | Meter No. | Calibration Date |
|------|---------------------------------|--------------|------------------------|------------|------------------------|
| 1 | TWO-LINE V-NETWORK | R&S | ENV216 | CT-1-025-1 | Mar. 27, 2015 |
| 2 | EMI Test Receiver | R&S | ESCI | CT-01-024 | Apr. 01, 2015 |
| 3 | Impedance Stabilization Network | FCC | F-071115-10 57-1-09 | CT-01-027 | Mar. 30, 2015 |
| 4 | TWO-LINE V-NETWORK | R&S | ENV216 | CT-1-025-2 | Mar. 27, 2015 |
| 5 | Test Cable | HANRUIN | 5D-FB | CT-1-069-1 | Aug. 05, 2015 |
| 6 | 50ohm Termination | N/A | N/A | CT-1-065-2 | Mar. 30, 2015 |
| 7 | Measurement Software | EZ-EMC | Ver: FA-03A | CT-3-012 | No calibration request |

Note: 1. The calibration interval of the above test instruments is 12 months.

4.2.3 Test Procedure

- a. The EUT was placed 0.4 meter from the horizontal ground plane with EUT being connected to power source through a line impedance stabilization network (LISN). The LISN at least be 80 cm from nearest chassis of EUT.
- b. The line impedance stabilization network (LISN) provides 50 ohm/50uH of coupling impedance for the measuring instrument. All other support equipments powered from additional LISN(s).
- c. Interrelating cables that hang closer than 40 cm to the ground plane shall be folded back and forth in the center forming a bundle. All I/O cables were positioned to simulate typical usage.
- d. All I/O cables that are not connected to a peripheral shall be bundle in the center. The end of the cable may be terminated, if required, using the correct terminating impedance. The overall length shall not exceed 1 m.
- e. ISN at least 80 cm from nearest chassis of EUT. The communication function of EUT was executed in normal condition. ISN was connected between EUT and associated equipment and ISN was connected directly to reference ground plane. The actual test configuration, please refer to EUT test photos.
- f. The receiver scanned from 150kHz to 30MHz for emissions in each of test modes. The test mode included 10Mbps, 100Mbps, 1Gbps and POE mode. Emission frequency and amplitude were recorded, recording at least six highest emissions.
- g. The EUT and cable configuration of the above highest emission levels were recorded. The test data of the worst case was recorded.

4.2.4 Deviation from Test Standard

No deviation

4.2.5 Test Setup

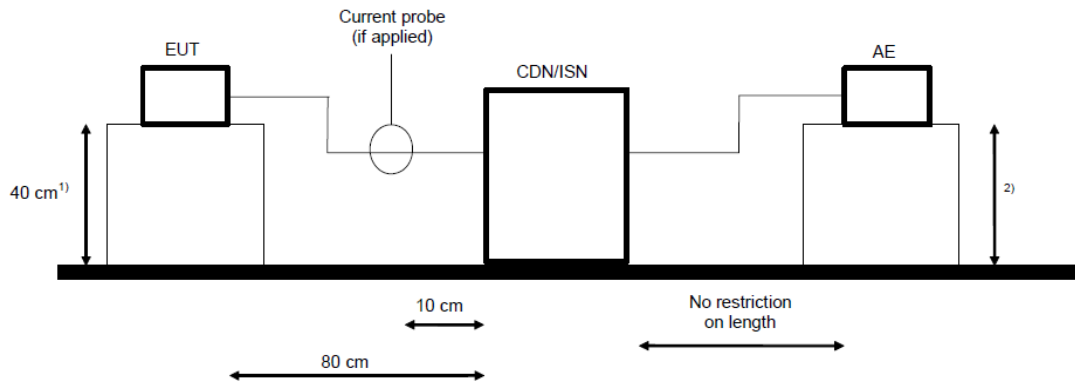

AE = Associated equipment
 EUT = Equipment under test

- 1) Distance to the reference groundplane (vertical or horizontal).
- 2) Distance to the reference groundplane is not critical.

Note: Please refer to the 4.2.7 for the actual test configuration.



4.2.6 Test Result

| | | | |
|---------------------------------|----------------------------|------------------------|--------------|
| Test Voltage | 230Vac, 50Hz | Frequency Range | 0.15-30 MHz |
| Environmental Conditions | 24.5°C, 56% RH | 6dB Bandwidth | 9 kHz |
| Test Date | 2015/12/18 | Tested by | Guanwei Liao |
| Test Condition | LAN port with ISN (10Mbps) | Test Mode | A |

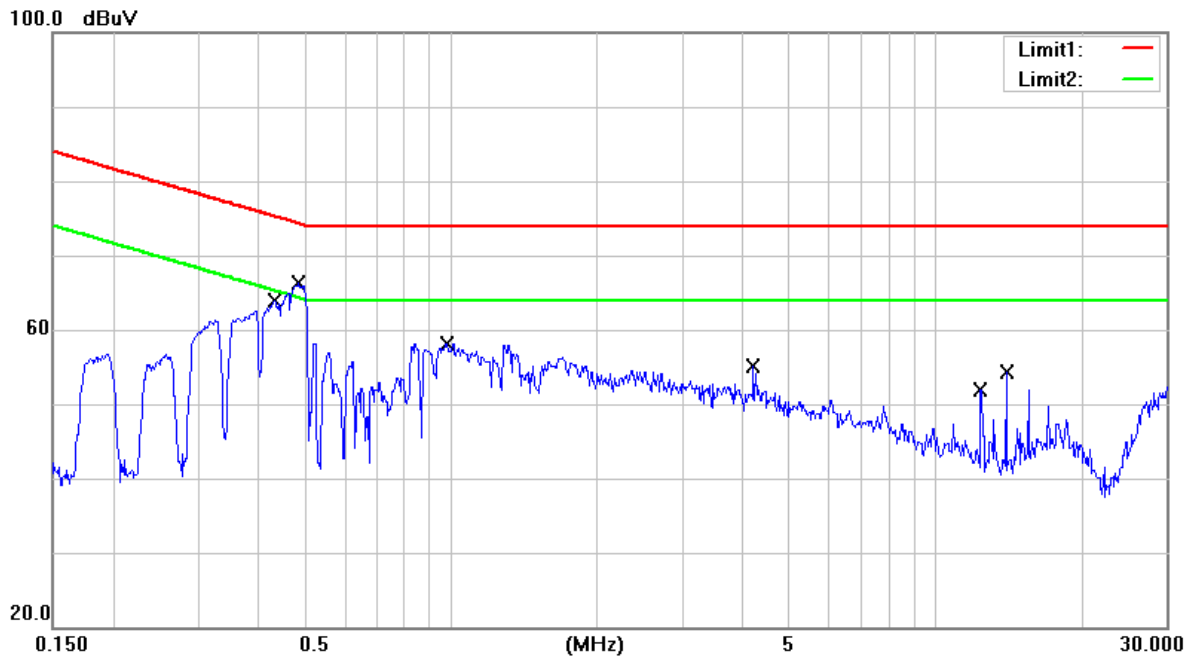

| No. | Frequency (MHz) | Reading Level (dBuV) | Correct Factor (dB) | Measurement (dBuV) | Limit (dBuV) | Margin (dB) | Detector |
|-----|-----------------|----------------------|---------------------|--------------------|--------------|-------------|----------|
| 1 | 0.4290 | 49.13 | 9.52 | 58.65 | 75.27 | -16.62 | QP |
| 2 | 0.4290 | 36.10 | 9.52 | 45.62 | 65.27 | -19.65 | AVG |
| 3 | 0.4815 | 55.07 | 9.48 | 64.55 | 74.31 | -9.76 | QP |
| 4 | 0.4815 | 42.55 | 9.48 | 52.03 | 64.31 | -12.28 | AVG |
| 5 | 0.9770 | 46.51 | 9.37 | 55.88 | 74.00 | -18.12 | QP |
| 6 | 0.9770 | 35.11 | 9.37 | 44.48 | 64.00 | -19.52 | AVG |
| 7 | 4.1855 | 38.40 | 9.27 | 47.67 | 74.00 | -26.33 | QP |
| 8 | 4.1855 | 32.06 | 9.27 | 41.33 | 64.00 | -22.67 | AVG |
| 9 | 12.4000 | 35.73 | 9.35 | 45.08 | 74.00 | -28.92 | QP |
| 10 | 12.4000 | 32.64 | 9.35 | 41.99 | 64.00 | -22.01 | AVG |
| 11 | 13.9500 | 36.75 | 9.38 | 46.13 | 74.00 | -27.87 | QP |
| 12 | 13.9500 | 33.24 | 9.38 | 42.62 | 64.00 | -21.38 | AVG |

Remark: 1. QP = Quasi Peak, AVG = Average
 2. Correction Factor = Insertion loss of ISN + Cable loss
 3. Measurement Value = Reading Level + Correct Factor
 4. Margin Level = Measurement Value - Limit Value



| | | | |
|---------------------------------|-----------------------------|------------------------|--------------|
| Test Voltage | 230Vac, 50Hz | Frequency Range | 0.15-30 MHz |
| Environmental Conditions | 24.5°C, 56% RH | 6dB Bandwidth | 9 kHz |
| Test Date | 2015/12/18 | Tested by | Guanwei Liao |
| Test Condition | LAN port with ISN (100Mbps) | Test Mode | A |

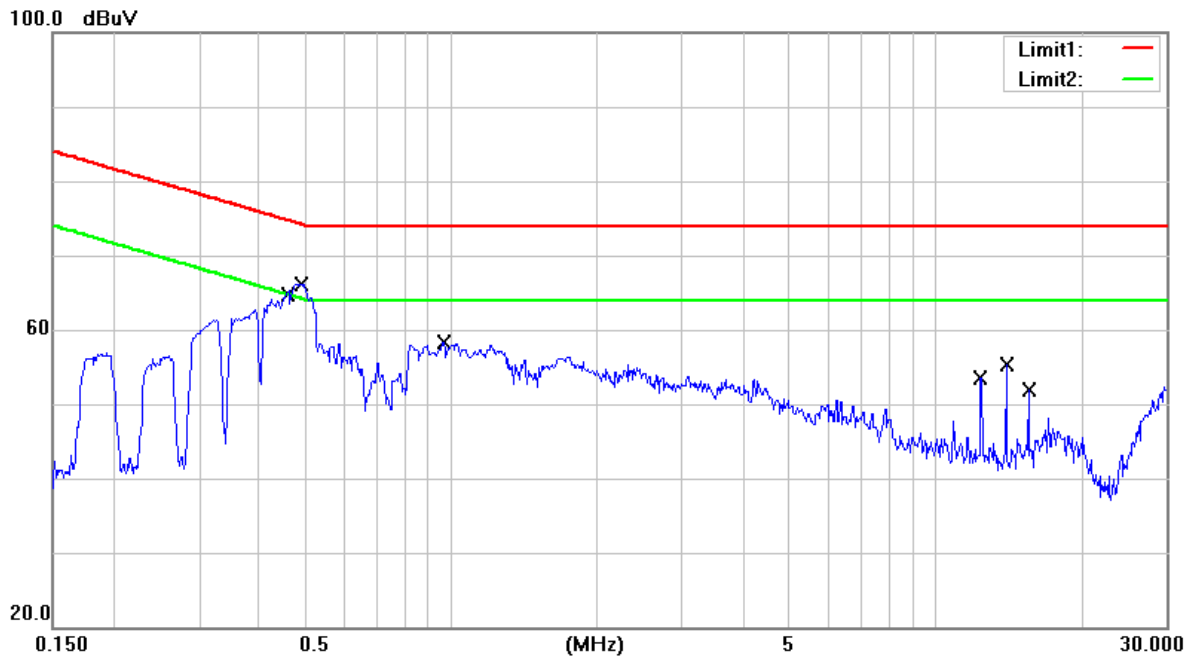

| No. | Frequency (MHz) | Reading Level (dBuV) | Correct Factor (dB) | Measurement (dBuV) | Limit (dBuV) | Margin (dB) | Detector |
|-----|-----------------|----------------------|---------------------|--------------------|--------------|-------------|----------|
| 1 | 0.4510 | 53.53 | 9.50 | 63.03 | 74.86 | -11.83 | QP |
| 2 | 0.4510 | 39.16 | 9.50 | 48.66 | 64.86 | -16.20 | AVG |
| 3 | 0.4881 | 54.78 | 9.48 | 64.26 | 74.20 | -9.94 | QP |
| 4 | 0.4881 | 42.05 | 9.48 | 51.53 | 64.20 | -12.67 | AVG |
| 5 | 0.9590 | 45.35 | 9.37 | 54.72 | 74.00 | -19.28 | QP |
| 6 | 0.9590 | 35.48 | 9.37 | 44.85 | 64.00 | -19.15 | AVG |
| 7 | 12.4000 | 34.67 | 9.35 | 44.02 | 74.00 | -29.98 | QP |
| 8 | 12.4000 | 31.39 | 9.35 | 40.74 | 64.00 | -23.26 | AVG |
| 9 | 13.9500 | 34.32 | 9.38 | 43.70 | 74.00 | -30.30 | QP |
| 10 | 13.9500 | 30.72 | 9.38 | 40.10 | 64.00 | -23.90 | AVG |
| 11 | 15.5000 | 32.00 | 9.40 | 41.40 | 74.00 | -32.60 | QP |
| 12 | 15.5000 | 27.45 | 9.40 | 36.85 | 64.00 | -27.15 | AVG |

Remark: 1. QP = Quasi Peak, AVG = Average
2. Correction Factor = Insertion loss of ISN + Cable loss
3. Measurement Value = Reading Level + Correct Factor
4. Margin Level = Measurement Value - Limit Value



| | | | |
|---------------------------------|---------------------------|------------------------|--------------|
| Test Voltage | 230Vac, 50Hz | Frequency Range | 0.15-30 MHz |
| Environmental Conditions | 24.5°C, 56% RH | 6dB Bandwidth | 9 kHz |
| Test Date | 2015/12/18 | Tested by | Guanwei Liao |
| Test Condition | LAN port with ISN (1Gbps) | Test Mode | A |

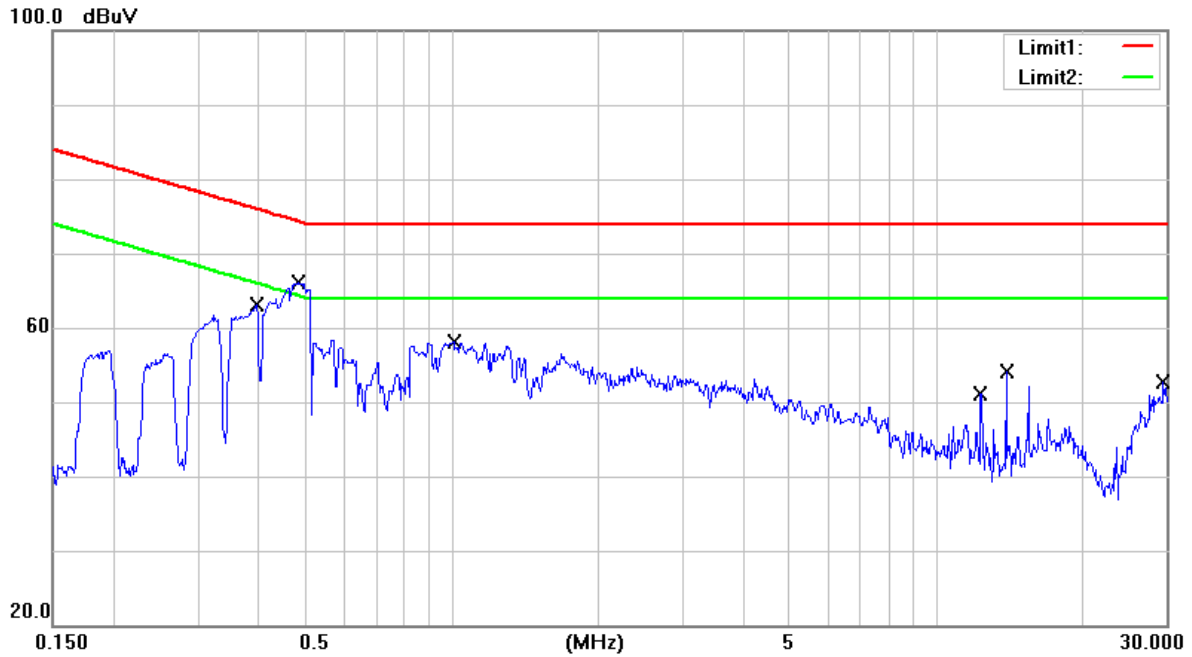

| No. | Frequency (MHz) | Reading Level (dBuV) | Correct Factor (dB) | Measurement (dBuV) | Limit (dBuV) | Margin (dB) | Detector |
|-----|-----------------|----------------------|---------------------|--------------------|--------------|-------------|----------|
| 1 | 0.3936 | 49.18 | 9.54 | 58.72 | 75.99 | -17.27 | QP |
| 2 | 0.3936 | 31.31 | 9.54 | 40.85 | 65.99 | -25.14 | AVG |
| 3 | 0.4815 | 55.05 | 9.48 | 64.53 | 74.31 | -9.78 | QP |
| 4 | 0.4815 | 42.54 | 9.48 | 52.02 | 64.31 | -12.29 | AVG |
| 5 | 1.0085 | 46.72 | 9.36 | 56.08 | 74.00 | -17.92 | QP |
| 6 | 1.0085 | 36.11 | 9.36 | 45.47 | 64.00 | -18.53 | AVG |
| 7 | 12.4000 | 32.32 | 9.35 | 41.67 | 74.00 | -32.33 | QP |
| 8 | 12.4000 | 28.42 | 9.35 | 37.77 | 64.00 | -26.23 | AVG |
| 9 | 13.9500 | 33.16 | 9.38 | 42.54 | 74.00 | -31.46 | QP |
| 10 | 13.9500 | 29.36 | 9.38 | 38.74 | 64.00 | -25.26 | AVG |
| 11 | 29.4500 | 37.83 | 9.75 | 47.58 | 74.00 | -26.42 | QP |
| 12 | 29.4500 | 32.51 | 9.75 | 42.26 | 64.00 | -21.74 | AVG |

Remark: 1. QP = Quasi Peak, AVG = Average
 2. Correction Factor = Insertion loss of ISN + Cable loss
 3. Measurement Value = Reading Level + Correct Factor
 4. Margin Level = Measurement Value - Limit Value



| | | | |
|---------------------------------|----------------------------|------------------------|--------------|
| Test Voltage | 230Vac, 50Hz | Frequency Range | 0.15-30 MHz |
| Environmental Conditions | 24.5°C, 56% RH | 6dB Bandwidth | 9 kHz |
| Test Date | 2015/12/18 | Tested by | Guanwei Liao |
| Test Condition | LAN port with ISN (10Mbps) | Test Mode | B |

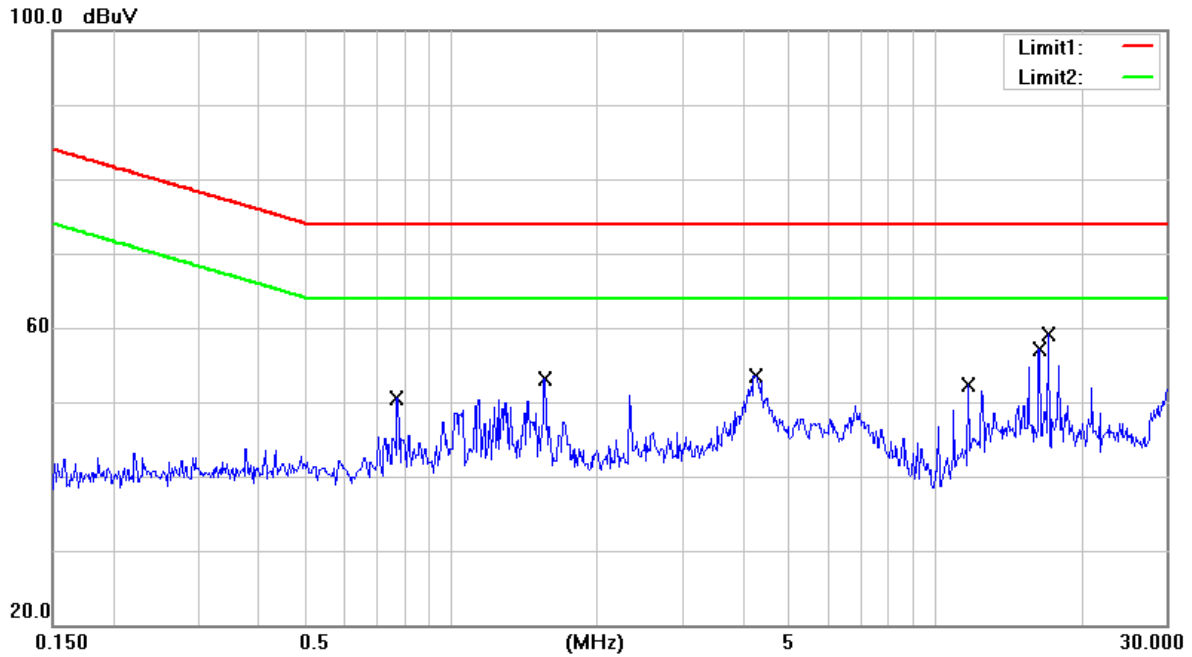

| No. | Frequency (MHz) | Reading Level (dBuV) | Correct Factor (dB) | Measurement (dBuV) | Limit (dBuV) | Margin (dB) | Detector |
|-----|-----------------|----------------------|---------------------|--------------------|--------------|-------------|----------|
| 1 | 0.7743 | 34.12 | 9.41 | 43.53 | 74.00 | -30.47 | QP |
| 2 | 0.7743 | 27.66 | 9.41 | 37.07 | 64.00 | -26.93 | AVG |
| 3 | 1.5529 | 41.56 | 9.33 | 50.89 | 74.00 | -23.11 | QP |
| 4 | 1.5529 | 33.85 | 9.33 | 43.18 | 64.00 | -20.82 | AVG |
| 5 | 4.2260 | 39.30 | 9.27 | 48.57 | 74.00 | -25.43 | QP |
| 6 | 4.2260 | 29.58 | 9.27 | 38.85 | 64.00 | -25.15 | AVG |
| 7 | 11.6500 | 31.45 | 9.34 | 40.79 | 74.00 | -33.21 | QP |
| 8 | 11.6500 | 25.71 | 9.34 | 35.05 | 64.00 | -28.95 | AVG |
| 9 | 16.3250 | 48.86 | 9.42 | 58.28 | 74.00 | -15.72 | QP |
| 10 | 16.3250 | 38.36 | 9.42 | 47.78 | 64.00 | -16.22 | AVG |
| 11 | 17.1000 | 49.68 | 9.43 | 59.11 | 74.00 | -14.89 | QP |
| 12 | 17.1000 | 38.45 | 9.43 | 47.88 | 64.00 | -16.12 | AVG |

Remark: 1. QP = Quasi Peak, AVG = Average
 2. Correction Factor = Insertion loss of ISN + Cable loss
 3. Measurement Value = Reading Level + Correct Factor
 4. Margin Level = Measurement Value - Limit Value



| | | | |
|---------------------------------|-----------------------------|------------------------|--------------|
| Test Voltage | 230Vac, 50Hz | Frequency Range | 0.15-30 MHz |
| Environmental Conditions | 24.5°C, 56% RH | 6dB Bandwidth | 9 kHz |
| Test Date | 2015/12/18 | Tested by | Guanwei Liao |
| Test Condition | LAN port with ISN (100Mbps) | Test Mode | B |

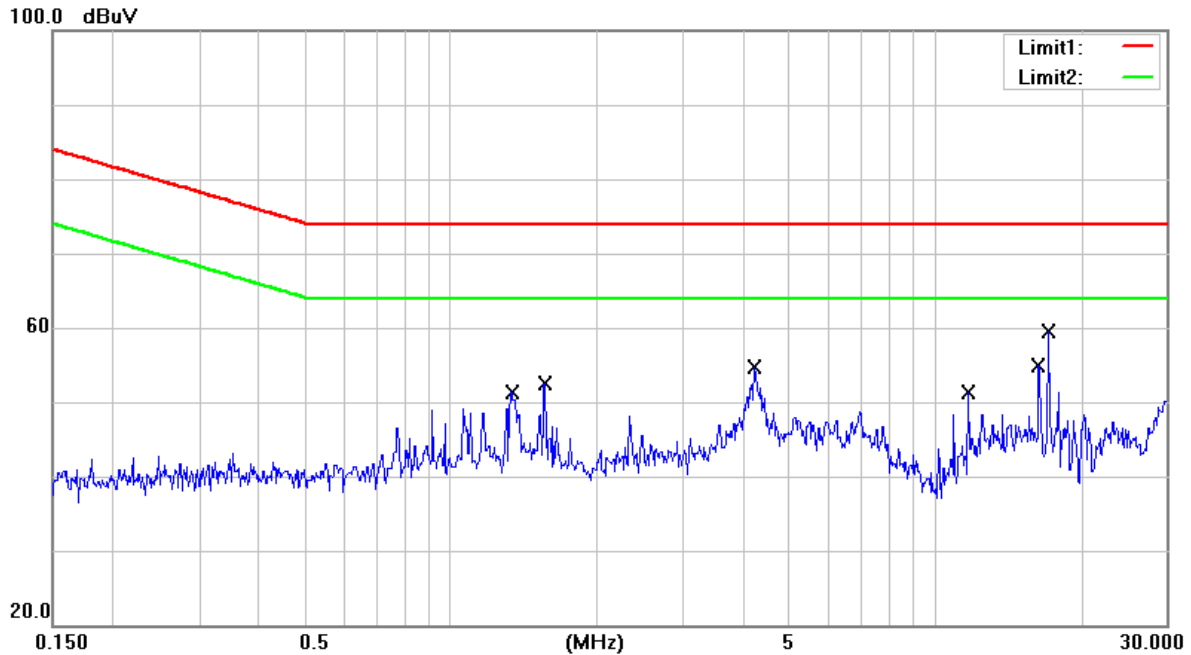

| No. | Frequency (MHz) | Reading Level (dBuV) | Correct Factor (dB) | Measurement (dBuV) | Limit (dBuV) | Margin (dB) | Detector |
|-----|-----------------|----------------------|---------------------|--------------------|--------------|-------------|----------|
| 1 | 1.3280 | 32.32 | 9.34 | 41.66 | 74.00 | -32.34 | QP |
| 2 | 1.3280 | 25.23 | 9.34 | 34.57 | 64.00 | -29.43 | AVG |
| 3 | 1.5530 | 41.58 | 9.33 | 50.91 | 74.00 | -23.09 | QP |
| 4 | 1.5530 | 33.78 | 9.33 | 43.11 | 64.00 | -20.89 | AVG |
| 5 | 4.2125 | 40.02 | 9.27 | 49.29 | 74.00 | -24.71 | QP |
| 6 | 4.2125 | 29.87 | 9.27 | 39.14 | 64.00 | -24.86 | AVG |
| 7 | 11.6500 | 31.46 | 9.34 | 40.80 | 74.00 | -33.20 | QP |
| 8 | 11.6500 | 25.50 | 9.34 | 34.84 | 64.00 | -29.16 | AVG |
| 9 | 16.3250 | 48.81 | 9.42 | 58.23 | 74.00 | -15.77 | QP |
| 10 | 16.3250 | 38.46 | 9.42 | 47.88 | 64.00 | -16.12 | AVG |
| 11 | 17.1000 | 48.86 | 9.43 | 58.29 | 74.00 | -15.71 | QP |
| 12 | 17.1000 | 38.01 | 9.43 | 47.44 | 64.00 | -16.56 | AVG |

Remark: 1. QP = Quasi Peak, AVG = Average
2. Correction Factor = Insertion loss of ISN + Cable loss
3. Measurement Value = Reading Level + Correct Factor
4. Margin Level = Measurement Value - Limit Value



| | | | |
|---------------------------------|---------------------------|------------------------|--------------|
| Test Voltage | 230Vac, 50Hz | Frequency Range | 0.15-30 MHz |
| Environmental Conditions | 24.5°C, 56% RH | 6dB Bandwidth | 9 kHz |
| Test Date | 2015/12/18 | Tested by | Guanwei Liao |
| Test Condition | LAN port with ISN (1Gbps) | Test Mode | B |

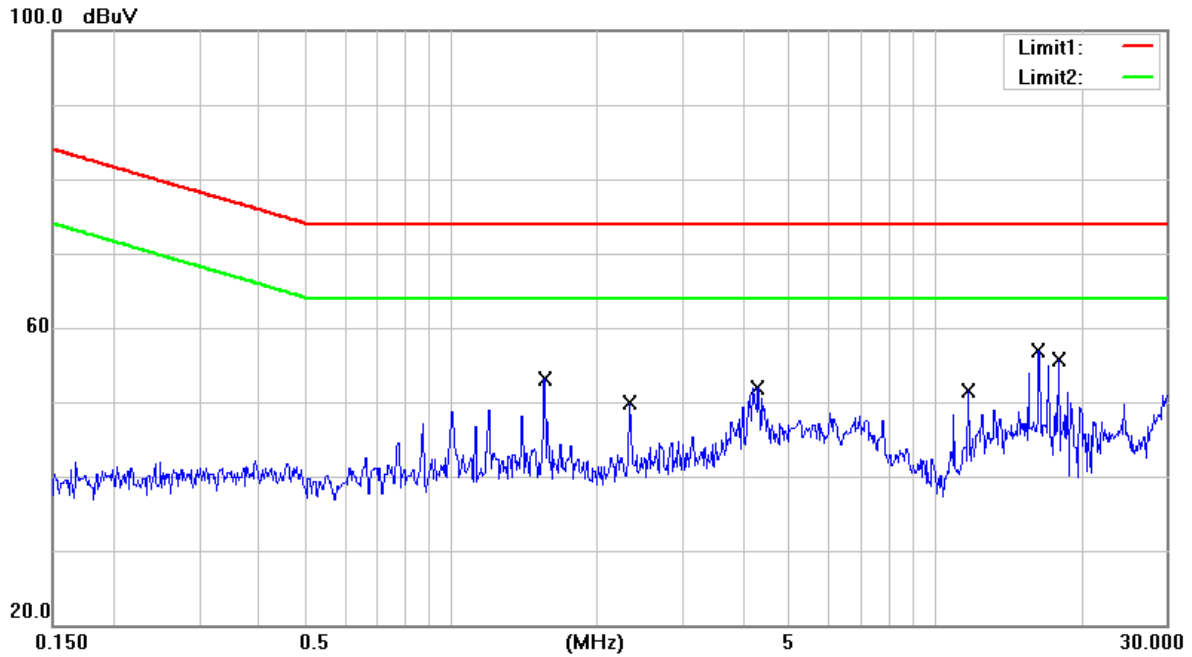

| No. | Frequency (MHz) | Reading Level (dBuV) | Correct Factor (dB) | Measurement (dBuV) | Limit (dBuV) | Margin (dB) | Detector |
|-----|-----------------|----------------------|---------------------|--------------------|--------------|-------------|----------|
| 1 | 1.5530 | 41.52 | 9.33 | 50.85 | 74.00 | -23.15 | QP |
| 2 | 1.5530 | 33.80 | 9.33 | 43.13 | 64.00 | -20.87 | AVG |
| 3 | 2.3315 | 38.83 | 9.29 | 48.12 | 74.00 | -25.88 | QP |
| 4 | 2.3315 | 33.32 | 9.29 | 42.61 | 64.00 | -21.39 | AVG |
| 5 | 4.2890 | 39.50 | 9.27 | 48.77 | 74.00 | -25.23 | QP |
| 6 | 4.2890 | 29.58 | 9.27 | 38.85 | 64.00 | -25.15 | AVG |
| 7 | 11.6750 | 31.39 | 9.34 | 40.73 | 74.00 | -33.27 | QP |
| 8 | 11.6750 | 25.53 | 9.34 | 34.87 | 64.00 | -29.13 | AVG |
| 9 | 16.3250 | 48.50 | 9.42 | 57.92 | 74.00 | -16.08 | QP |
| 10 | 16.3250 | 38.38 | 9.42 | 47.80 | 64.00 | -16.20 | AVG |
| 11 | 17.8750 | 42.25 | 9.44 | 51.69 | 74.00 | -22.31 | QP |
| 12 | 17.8750 | 31.58 | 9.44 | 41.02 | 64.00 | -22.98 | AVG |

Remark: 1. QP = Quasi Peak, AVG = Average
 2. Correction Factor = Insertion loss of ISN + Cable loss
 3. Measurement Value = Reading Level + Correct Factor
 4. Margin Level = Measurement Value - Limit Value



| | | | |
|---------------------------------|----------------------------|------------------------|--------------|
| Test Voltage | 48Vdc (POE) | Frequency Range | 0.15-30 MHz |
| Environmental Conditions | 24.5°C, 56% RH | 6dB Bandwidth | 9 kHz |
| Test Date | 2015/12/18 | Tested by | Guanwei Liao |
| Test Condition | LAN port with ISN (10Mbps) | Test Mode | C |

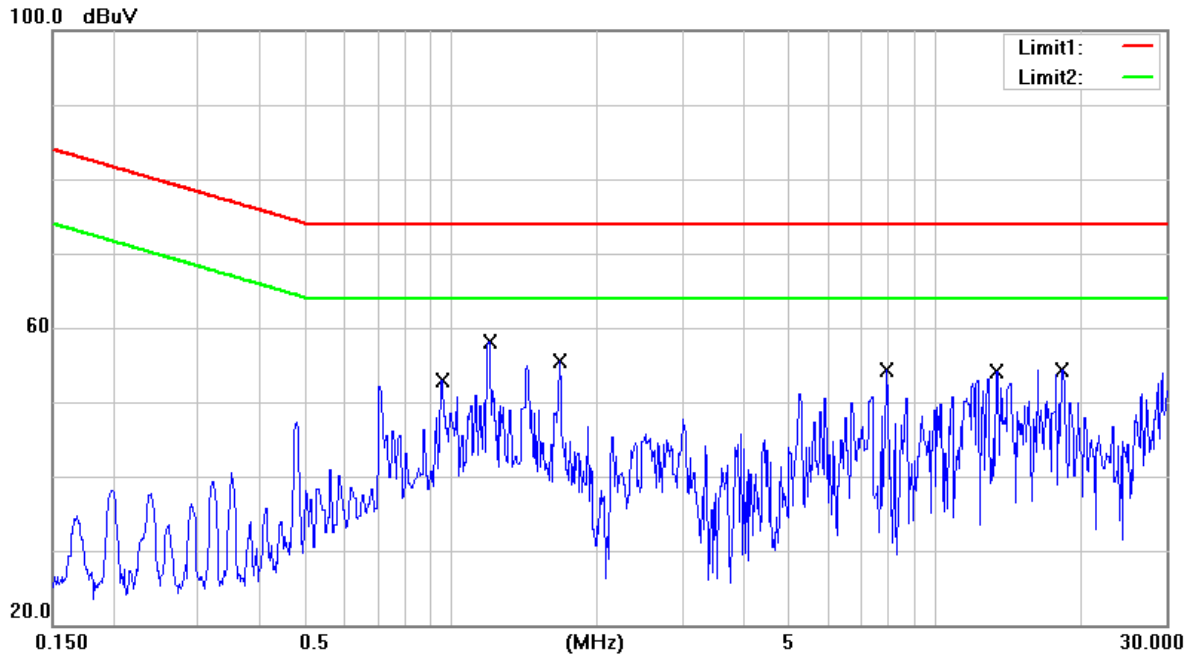

| No. | Frequency (MHz) | Reading Level (dBuV) | Correct Factor (dB) | Measurement (dBuV) | Limit (dBuV) | Margin (dB) | Detector |
|-----|-----------------|----------------------|---------------------|--------------------|--------------|-------------|----------|
| 1 | 0.9545 | 42.14 | 9.37 | 51.51 | 74.00 | -22.49 | QP |
| 2 | 0.9545 | 38.46 | 9.37 | 47.83 | 64.00 | -16.17 | AVG |
| 3 | 1.1930 | 47.63 | 9.35 | 56.98 | 74.00 | -17.02 | QP |
| 4 | 1.1930 | 47.04 | 9.35 | 56.39 | 64.00 | -7.61 | AVG |
| 5 | 1.6700 | 43.23 | 9.32 | 52.55 | 74.00 | -21.45 | QP |
| 6 | 1.6700 | 42.97 | 9.32 | 52.29 | 64.00 | -11.71 | AVG |
| 7 | 7.9250 | 42.70 | 9.29 | 51.99 | 74.00 | -22.01 | QP |
| 8 | 7.9250 | 41.32 | 9.29 | 50.61 | 64.00 | -13.39 | AVG |
| 9 | 13.3500 | 25.65 | 9.36 | 35.01 | 74.00 | -38.99 | QP |
| 10 | 13.3500 | 24.53 | 9.36 | 33.89 | 64.00 | -30.11 | AVG |
| 11 | 18.2500 | 33.17 | 9.45 | 42.62 | 74.00 | -31.38 | QP |
| 12 | 18.2500 | 32.52 | 9.45 | 41.97 | 64.00 | -22.03 | AVG |

Remark: 1. QP = Quasi Peak, AVG = Average
 2. Correction Factor = Insertion loss of ISN + Cable loss
 3. Measurement Value = Reading Level + Correct Factor
 4. Margin Level = Measurement Value - Limit Value



| | | | |
|---------------------------------|-----------------------------|------------------------|--------------|
| Test Voltage | 48Vdc (POE) | Frequency Range | 0.15-30 MHz |
| Environmental Conditions | 24.5°C, 56% RH | 6dB Bandwidth | 9 kHz |
| Test Date | 2015/12/18 | Tested by | Guanwei Liao |
| Test Condition | LAN port with ISN (100Mbps) | Test Mode | C |

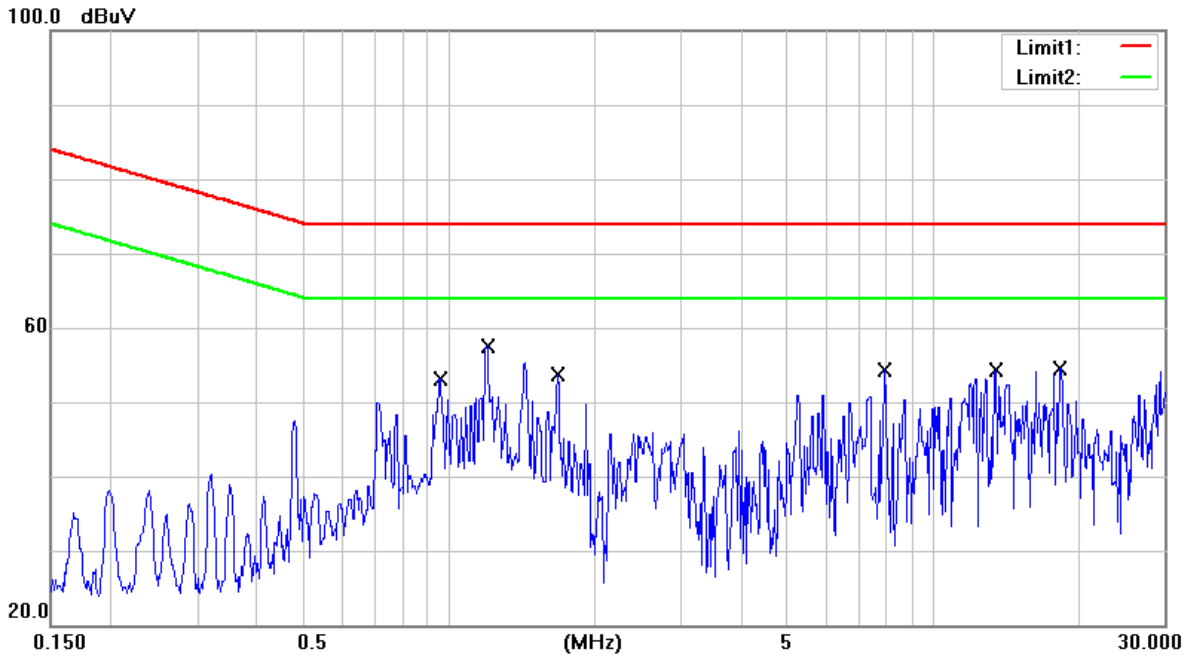

| No. | Frequency (MHz) | Reading Level (dBuV) | Correct Factor (dB) | Measurement (dBuV) | Limit (dBuV) | Margin (dB) | Detector |
|-----|-----------------|----------------------|---------------------|--------------------|--------------|-------------|----------|
| 1 | 0.9545 | 42.13 | 9.37 | 51.50 | 74.00 | -22.50 | QP |
| 2 | 0.9545 | 38.45 | 9.37 | 47.82 | 64.00 | -16.18 | AVG |
| 3 | 1.1930 | 47.41 | 9.35 | 56.76 | 74.00 | -17.24 | QP |
| 4 | 1.1930 | 46.77 | 9.35 | 56.12 | 64.00 | -7.88 | AVG |
| 5 | 1.6700 | 43.44 | 9.32 | 52.76 | 74.00 | -21.24 | QP |
| 6 | 1.6700 | 43.22 | 9.32 | 52.54 | 64.00 | -11.46 | AVG |
| 7 | 7.9250 | 42.78 | 9.29 | 52.07 | 74.00 | -21.93 | QP |
| 8 | 7.9250 | 41.32 | 9.29 | 50.61 | 64.00 | -13.39 | AVG |
| 9 | 13.4250 | 36.01 | 9.36 | 45.37 | 74.00 | -28.63 | QP |
| 10 | 13.4250 | 35.25 | 9.36 | 44.61 | 64.00 | -19.39 | AVG |
| 11 | 18.2500 | 33.28 | 9.45 | 42.73 | 74.00 | -31.27 | QP |
| 12 | 18.2500 | 32.57 | 9.45 | 42.02 | 64.00 | -21.98 | AVG |

Remark: 1. QP = Quasi Peak, AVG = Average
 2. Correction Factor = Insertion loss of ISN + Cable loss
 3. Measurement Value = Reading Level + Correct Factor
 4. Margin Level = Measurement Value - Limit Value



| | | | |
|---------------------------------|---------------------------|------------------------|--------------|
| Test Voltage | 48Vdc (POE) | Frequency Range | 0.15-30 MHz |
| Environmental Conditions | 24.5°C, 56% RH | 6dB Bandwidth | 9 kHz |
| Test Date | 2015/12/18 | Tested by | Guanwei Liao |
| Test Condition | LAN port with ISN (1Gbps) | Test Mode | C |

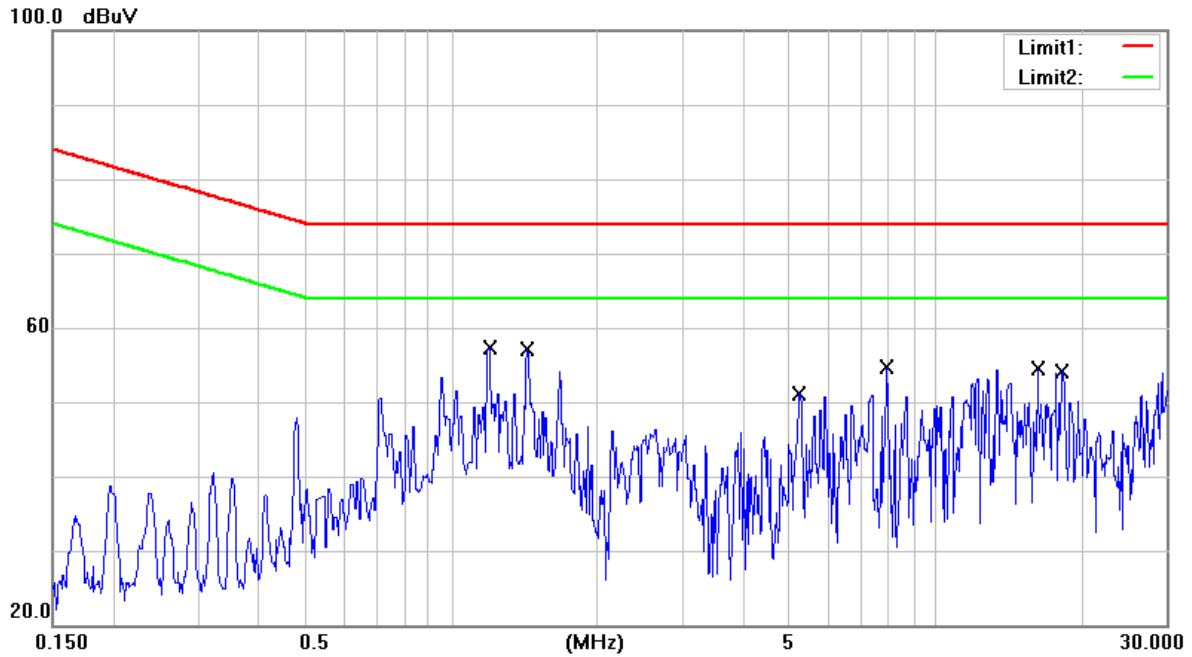

| No. | Frequency (MHz) | Reading Level (dBuV) | Correct Factor (dB) | Measurement (dBuV) | Limit (dBuV) | Margin (dB) | Detector |
|-----|-----------------|----------------------|---------------------|--------------------|--------------|-------------|----------|
| 1 | 1.1930 | 47.51 | 9.35 | 56.86 | 74.00 | -17.14 | QP |
| 2 | 1.1930 | 46.86 | 9.35 | 56.21 | 64.00 | -7.79 | AVG |
| 3 | 1.4315 | 44.95 | 9.33 | 54.28 | 74.00 | -19.72 | QP |
| 4 | 1.4315 | 44.59 | 9.33 | 53.92 | 64.00 | -10.08 | AVG |
| 5 | 5.2250 | 11.91 | 9.26 | 21.17 | 74.00 | -52.83 | QP |
| 6 | 5.2250 | 6.79 | 9.26 | 16.05 | 64.00 | -47.95 | AVG |
| 7 | 7.9250 | 42.83 | 9.29 | 52.12 | 74.00 | -21.88 | QP |
| 8 | 7.9250 | 41.32 | 9.29 | 50.61 | 64.00 | -13.39 | AVG |
| 9 | 16.2250 | 42.33 | 9.41 | 51.74 | 74.00 | -22.26 | QP |
| 10 | 16.2250 | 40.80 | 9.41 | 50.21 | 64.00 | -13.79 | AVG |
| 11 | 18.2500 | 33.12 | 9.45 | 42.57 | 74.00 | -31.43 | QP |
| 12 | 18.2500 | 32.52 | 9.45 | 41.97 | 64.00 | -22.03 | AVG |

Remark: 1. QP = Quasi Peak, AVG = Average
 2. Correction Factor = Insertion loss of ISN + Cable loss
 3. Measurement Value = Reading Level + Correct Factor
 4. Margin Level = Measurement Value - Limit Value

4.2.7 Photographs of Test Configuration

Test Mode A



Test Mode B



Test Mode C



4.3 Radiated Emission Measurement

4.3.1 Limits of Radiated Emission Measurement

Radiated Frequency range 30 MHz to 1000 MHz

| Frequency (MHz) | Class A (at 10m) | Class B (at 10m) |
|-----------------|------------------|------------------|
| | dBuV/m | dBuV/m |
| 30 to 230 | 40 | 30 |
| 230 to 1000 | 47 | 37 |

Note: 1. The lower limit shall apply at the transition frequency.

Radiated Frequency range above 1 GHz

| Frequency (GHz) | Class A (at 3m) | | Class B (at 3m) | |
|-----------------|------------------|---------------|------------------|---------------|
| | Average (dBuV/m) | Peak (dBuV/m) | Average (dBuV/m) | Peak (dBuV/m) |
| 1 to 3 | 56 | 76 | 50 | 70 |
| 3 to 6 | 60 | 80 | 54 | 74 |

- Note:**
1. The lower limit shall apply at the transition frequency.
 2. Detector function in the form: PK = Peak, QP = Quasi Peak, AV = Average
 3. The test result calculated as following:
 Measurement Value = Reading Level + Correct Factor
 Correction Factor = Antenna factor + Cable loss (Antenna to preamplifier) - preamplifier Gain
 + Cable loss (preamplifier to receiver)
 Margin Level = Measurement Value - Limit Value
 4. Maximum internal signal source is defined as the maximum frequency of the device under test, or EUT highest frequency tuning of the operation or in the production or use of the device under test.
 5. If the maximum frequency of the device under test is less than the internal source of 108MHz, the only measure to 1GHz.
 6. If the maximum frequency of the device between 108MHz and 500MHz maximum frequency of the device under test ranged from internal sources, you must measure to 2GHz.
 7. If the maximum frequency of the device under test between internal source of 500MHz and 1GHz, you must measure to 5GHz.
 8. If the maximum frequency of the device under test is higher than the internal source of 1GHz, it must measure up to the maximum frequency of 5 times or 6GHz, choosing the less.



4.3.2 Test Instrument

| Item | Equipment | Manufacturer | Model | Meter No. | Calibration Date |
|------|----------------------|----------------------------|---------------------|------------|------------------------|
| 1 | Horn Antenna | Schwarzbeck | BBHA 9120 D | CT-1-001 | Apr. 01, 2015 |
| 2 | Bilog Antenna | Schwarzbeck | VULB 9168 | CT-1-002-1 | Mar. 30, 2015 |
| 3 | Test Cable | HARUIN | CFD400NL-LW | CT-1-070 | Aug. 05, 2015 |
| 4 | Preamplifier | EM Electronics Corporation | EM30265 | CT-1-013 | Aug. 05, 2015 |
| 5 | Test Cable | HARBOUR | 27478 LL142 | CT-1-073 | Aug. 03, 2015 |
| 6 | EMI Test Receiver | Agilent | N9038A | CT-1-068 | Aug. 06, 2015 |
| 7 | Measurement Software | Ez-EMC | Ver : FA-03A2 RE | CT-3-012 | No calibration request |

Note: 1. The calibration interval of the above test instruments is 12 months.

4.3.3 Test Procedure

- a. The EUT was placed on the top of a turntable 0.8 meters above the ground at a 3 m or 10 m open area test site. The table was rotated 360 degrees to determine the position of the high radiation emissions.
- b. The height of the test antenna shall vary between 1 m to 4 m. Both vertical and horizontal polarizations of the antenna were set to make the measurement.
- c. The EUT was set up as per the test configuration to simulate typical usage per the user's manual. All I/O cables were positioned to simulate typical usage. The actual test configuration, please refer to EUT test photos.
- d. The initial step in collecting radiated emission data is a Spectrum Mode scanning the measurement frequency range.

Blow 1GHz:

Reading in which marked as QP or Peak means measurements by using Spectrum Mode with detector RBW=120kHz.

If the Spectrum Mode measured peak value compliance with and lower than Quasi Peak Limit, the EUT shall be deemed to meet QP Limits.

Above 1GHz:

Reading in which marked as Peak & AVG means measurements by using Spectrum Mode with setting in RBW=1MHz.

If the Spectrum Mode measured value compliance with the Peak Limits and lower than AVG Limits, the EUT shall be deemed to meet both Peak and AVG Limits.

- e. Emission frequency and amplitude were recorded, recording at least six highest emissions. The EUT and cable configuration of the above highest emission levels were recorded. The test data of the worst case was recorded.

4.3.4 Deviation from Test Standard

No deviation

4.3.5 Test Setup

< Radiated Emissions Frequency: 30 MHz to 1000 MHz >

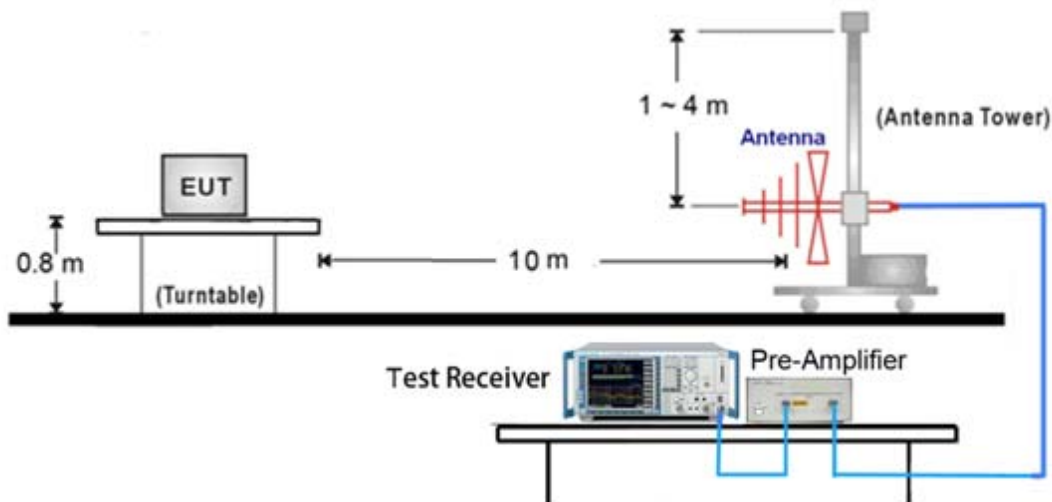

< Radiated Emissions Frequency: above 1GHz >

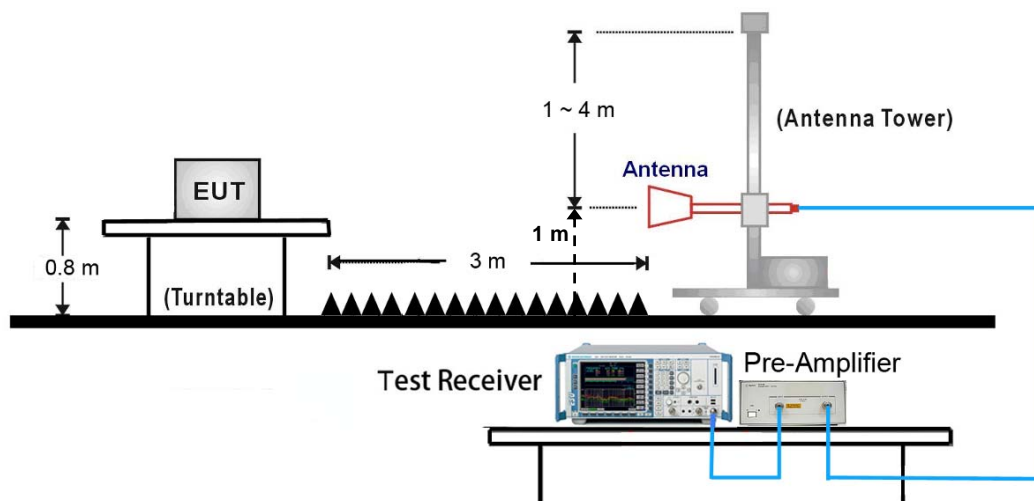

Note:

- (1) Please refer to the 4.3.7 for the actual test configuration.
- (2) The formula of measured value as: $\text{Test Result} = \text{Reading} + \text{Correction Factor}$
- (3) Detector function in the form: PK = Peak, QP = Quasi Peak, AV = Average
- (4) The test result calculated as following:
 $\text{Measurement Value} = \text{Reading Level} + \text{Correct Factor}$
 $\text{Correct Factor} = \text{Antenna Factor} + \text{Cable Loss} - \text{Amplifier Gain (if use)}$
 $\text{Margin Level} = \text{Measurement Value} - \text{Limit Value}$



4.3.6 Test Result

| | | | |
|--------------------------|---------------|-----------------|---------------|
| Test Voltage | 230Vac, 50Hz | Frequency Range | 30 – 1000 MHz |
| Environmental Conditions | 18°C, 57% RH | 6dB Bandwidth | 120 kHz |
| Test Date | 2015/12/21 | Test Distance | 10m |
| Tested by | HsiangAn Hung | Polarization | Vertical |
| Test Mode | A | | |

90.0 dBuV/m

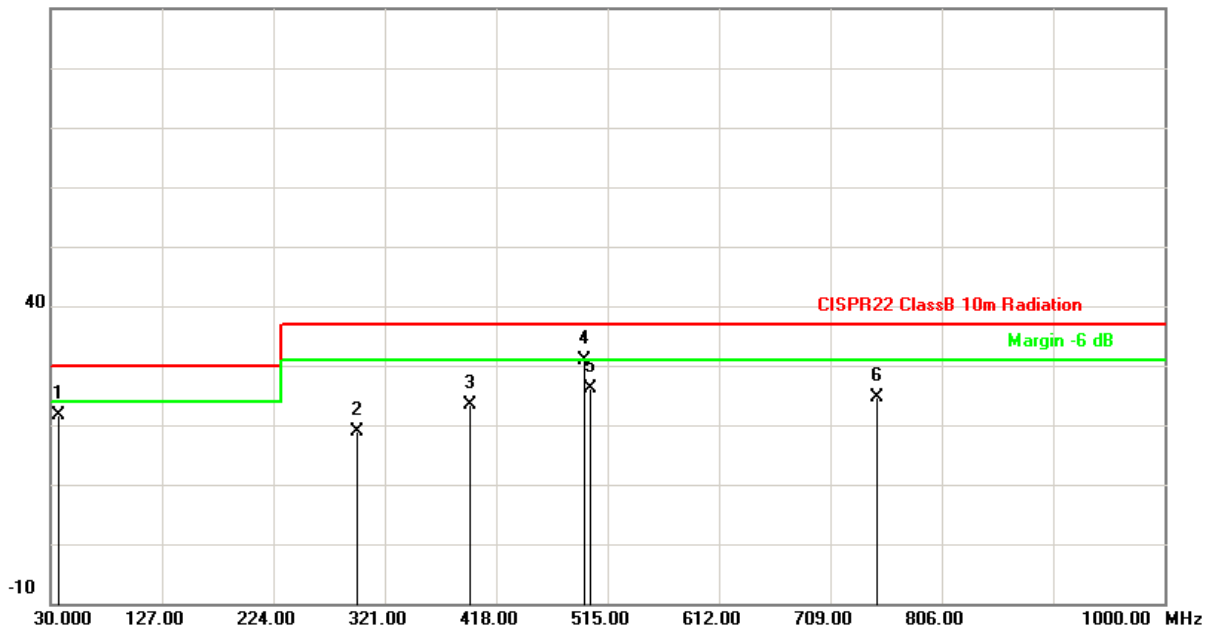

| No. | Frequency (MHz) | Reading Level (dBuV) | Correct Factor (dB) | Measurement (dBuV) | Limit (dBuV) | Margin (dB) | Detector | Antenna Height (cm) | Table Degree (degree) |
|-----|-----------------|----------------------|---------------------|--------------------|--------------|-------------|----------|---------------------|-----------------------|
| 1 | 37.2500 | 45.91 | -24.21 | 21.70 | 30.00 | -8.30 | QP | 100 | 281 |
| 2 | 297.0000 | 45.83 | -26.95 | 18.88 | 37.00 | -18.12 | QP | 100 | 264 |
| 3 | 396.0000 | 47.56 | -24.30 | 23.26 | 37.00 | -13.74 | QP | 100 | 263 |
| 4 | 495.0000 | 52.69 | -21.73 | 30.96 | 37.00 | -6.04 | QP | 100 | 254 |
| 5 | 500.0000 | 47.74 | -21.64 | 26.10 | 37.00 | -10.90 | QP | 100 | 255 |
| 6 | 750.0000 | 41.25 | -16.68 | 24.57 | 37.00 | -12.43 | QP | 100 | 247 |

Remark: 1. QP = Quasi Peak

2. Correction Factor = Antenna factor + Cable loss (Antenna to preamplifier) - preamplifier Gain + Cable loss (preamplifier to receiver)

3. Measurement Value = Reading Level + Correct Factor

4. Margin Level = Measurement Value - Limit Value



| | | | |
|---------------------------------|---------------|------------------------|---------------|
| Test Voltage | 230Vac, 50Hz | Frequency Range | 30 – 1000 MHz |
| Environmental Conditions | 18°C, 57% RH | 6dB Bandwidth | 120 kHz |
| Test Date | 2015/12/21 | Test Distance | 10m |
| Tested by | HsiangAn Hung | Polarization | Horizontal |
| Test Mode | A | | |

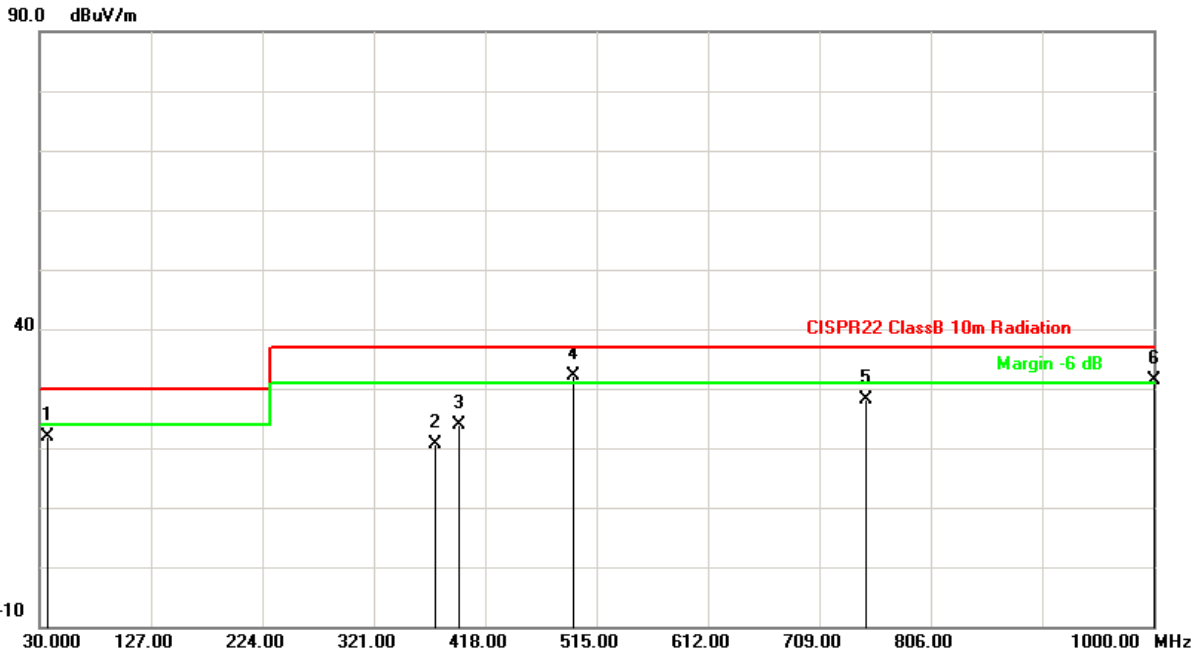

| No. | Frequency (MHz) | Reading Level (dBuV) | Correct Factor (dB) | Measurement (dBuV) | Limit (dBuV) | Margin (dB) | Detector | Antenna Height (cm) | Table Degree (degree) |
|-----|-----------------|----------------------|---------------------|--------------------|--------------|-------------|----------|---------------------|-----------------------|
| 1 | 37.2100 | 45.97 | -24.21 | 21.76 | 30.00 | -8.24 | QP | 389 | 175 |
| 2 | 375.0000 | 45.62 | -24.94 | 20.68 | 37.00 | -16.32 | QP | 233 | 231 |
| 3 | 396.0000 | 48.11 | -24.30 | 23.81 | 37.00 | -13.19 | QP | 256 | 76 |
| 4 | 495.0000 | 53.89 | -21.73 | 32.16 | 37.00 | -4.84 | QP | 153 | 328 |
| 5 | 750.0000 | 44.73 | -16.68 | 28.05 | 37.00 | -8.95 | QP | 146 | 199 |
| 6 | 1000.0000 | 45.20 | -13.81 | 31.39 | 37.00 | -5.61 | QP | 171 | 150 |

Remark: 1. QP = Quasi Peak
 2. Correction Factor = Antenna factor + Cable loss (Antenna to preamplifier) - preamplifier Gain + Cable loss (preamplifier to receiver)
 3. Measurement Value = Reading Level + Correct Factor
 4. Margin Level = Measurement Value - Limit Value



| | | | |
|---------------------------------|---------------|------------------------|---------------|
| Test Voltage | 230Vac, 50Hz | Frequency Range | 30 – 1000 MHz |
| Environmental Conditions | 18°C, 57% RH | 6dB Bandwidth | 120 kHz |
| Test Date | 2015/12/21 | Test Distance | 10m |
| Tested by | HsiangAn Hung | Polarization | Vertical |
| Test Mode | B | | |

90.0 dBuV/m

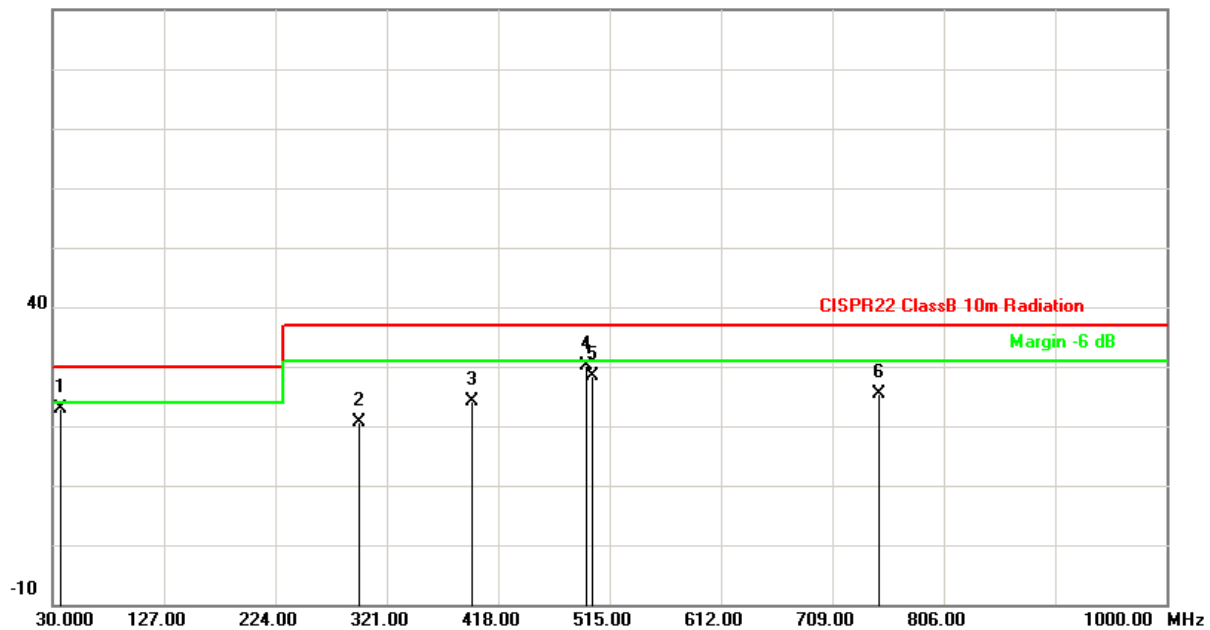

| No. | Frequency (MHz) | Reading Level (dBuV) | Correct Factor (dB) | Measurement (dBuV) | Limit (dBuV) | Margin (dB) | Detector | Antenna Height (cm) | Table Degree (degree) |
|-----|-----------------|----------------------|---------------------|--------------------|--------------|-------------|----------|---------------------|-----------------------|
| 1 | 37.2400 | 47.11 | -24.21 | 22.90 | 30.00 | -7.10 | QP | 100 | 104 |
| 2 | 297.0000 | 47.46 | -26.95 | 20.51 | 37.00 | -16.49 | QP | 100 | 258 |
| 3 | 396.0000 | 48.52 | -24.30 | 24.22 | 37.00 | -12.78 | QP | 100 | 263 |
| 4 | 495.0000 | 51.88 | -21.73 | 30.15 | 37.00 | -6.85 | QP | 100 | 288 |
| 5 | 500.0000 | 50.09 | -21.64 | 28.45 | 37.00 | -8.55 | QP | 100 | 284 |
| 6 | 750.0000 | 42.13 | -16.68 | 25.45 | 37.00 | -11.55 | QP | 100 | 239 |

Remark:

1. QP = Quasi Peak
2. Correction Factor = Antenna factor + Cable loss (Antenna to preamplifier) - preamplifier Gain + Cable loss (preamplifier to receiver)
3. Measurement Value = Reading Level + Correct Factor
4. Margin Level = Measurement Value - Limit Value



| | | | |
|---------------------------------|---------------|------------------------|---------------|
| Test Voltage | 230Vac, 50Hz | Frequency Range | 30 – 1000 MHz |
| Environmental Conditions | 18°C, 57% RH | 6dB Bandwidth | 120 kHz |
| Test Date | 2015/12/21 | Test Distance | 10m |
| Tested by | HsiangAn Hung | Polarization | Horizontal |
| Test Mode | B | | |

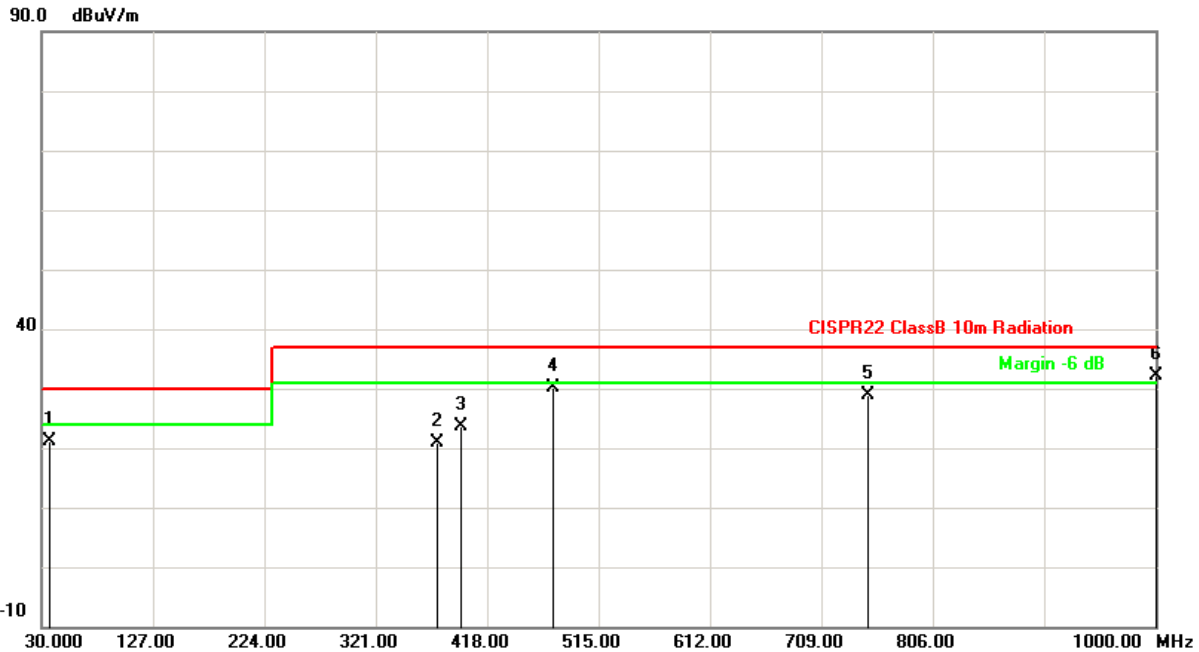

| No. | Frequency (MHz) | Reading Level (dBuV) | Correct Factor (dB) | Measurement (dBuV) | Limit (dBuV) | Margin (dB) | Detector | Antenna Height (cm) | Table Degree (degree) |
|-----|-----------------|----------------------|---------------------|--------------------|--------------|-------------|----------|---------------------|-----------------------|
| 1 | 37.2599 | 45.28 | -24.20 | 21.08 | 30.00 | -8.92 | QP | 400 | 185 |
| 2 | 375.0000 | 45.74 | -24.94 | 20.80 | 37.00 | -16.20 | QP | 259 | 229 |
| 3 | 396.0000 | 47.91 | -24.30 | 23.61 | 37.00 | -13.39 | QP | 244 | 77 |
| 4 | 475.0000 | 52.21 | -22.08 | 30.13 | 37.00 | -6.87 | QP | 173 | 149 |
| 5 | 750.0000 | 45.66 | -16.68 | 28.98 | 37.00 | -8.02 | QP | 135 | 192 |
| 6 | 1000.0000 | 46.03 | -13.81 | 32.22 | 37.00 | -4.78 | QP | 177 | 171 |

Remark: 1. QP = Quasi Peak
 2. Correction Factor = Antenna factor + Cable loss (Antenna to preamplifier) - preamplifier Gain + Cable loss (preamplifier to receiver)
 3. Measurement Value = Reading Level + Correct Factor
 4. Margin Level = Measurement Value - Limit Value



| | | | |
|---------------------------------|---------------|------------------------|---------------|
| Test Voltage | 48Vdc (POE) | Frequency Range | 30 – 1000 MHz |
| Environmental Conditions | 18°C, 57% RH | 6dB Bandwidth | 120 kHz |
| Test Date | 2015/12/21 | Test Distance | 10m |
| Tested by | HsiangAn Hung | Polarization | Vertical |
| Test Mode | C | | |

90.0 dBuV/m

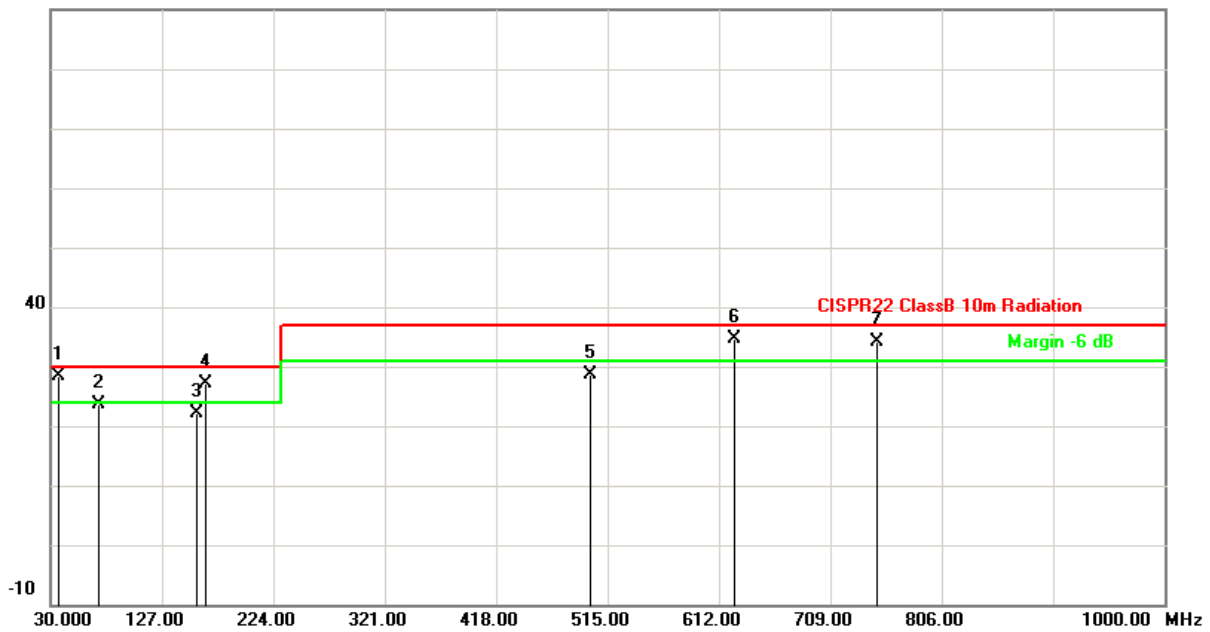

| No. | Frequency (MHz) | Reading Level (dBuV) | Correct Factor (dB) | Measurement (dBuV) | Limit (dBuV) | Margin (dB) | Detector | Antenna Height (cm) | Table Degree (degree) |
|-----|-----------------|----------------------|---------------------|--------------------|--------------|-------------|----------|---------------------|-----------------------|
| 1 | 37.3500 | 52.58 | -24.21 | 28.37 | 30.00 | -1.63 | QP | 100 | 16 |
| 2 | 72.5630 | 51.28 | -27.58 | 23.70 | 30.00 | -6.30 | QP | 100 | 34 |
| 3 | 157.5120 | 48.70 | -26.51 | 22.19 | 30.00 | -7.81 | QP | 100 | 66 |
| 4 | 165.1300 | 54.05 | -26.93 | 27.12 | 30.00 | -2.88 | QP | 100 | 251 |
| 5 | 500.0110 | 50.30 | -21.64 | 28.66 | 37.00 | -8.34 | QP | 116 | 137 |
| 6 | 625.0140 | 53.50 | -18.90 | 34.60 | 37.00 | -2.40 | QP | 106 | 270 |
| 7 | 750.0160 | 50.93 | -16.68 | 34.25 | 37.00 | -2.75 | QP | 100 | 208 |

Remark: 1. QP = Quasi Peak
 2. Correction Factor = Antenna factor + Cable loss (Antenna to preamplifier) - preamplifier Gain + Cable loss (preamplifier to receiver)
 3. Measurement Value = Reading Level + Correct Factor
 4. Margin Level = Measurement Value - Limit Value



| | | | |
|---------------------------------|---------------|------------------------|---------------|
| Test Voltage | 48Vdc (POE) | Frequency Range | 30 – 1000 MHz |
| Environmental Conditions | 18°C, 57% RH | 6dB Bandwidth | 120 kHz |
| Test Date | 2015/12/21 | Test Distance | 10m |
| Tested by | HsiangAn Hung | Polarization | Horizontal |
| Test Mode | C | | |

90.0 dBuV/m

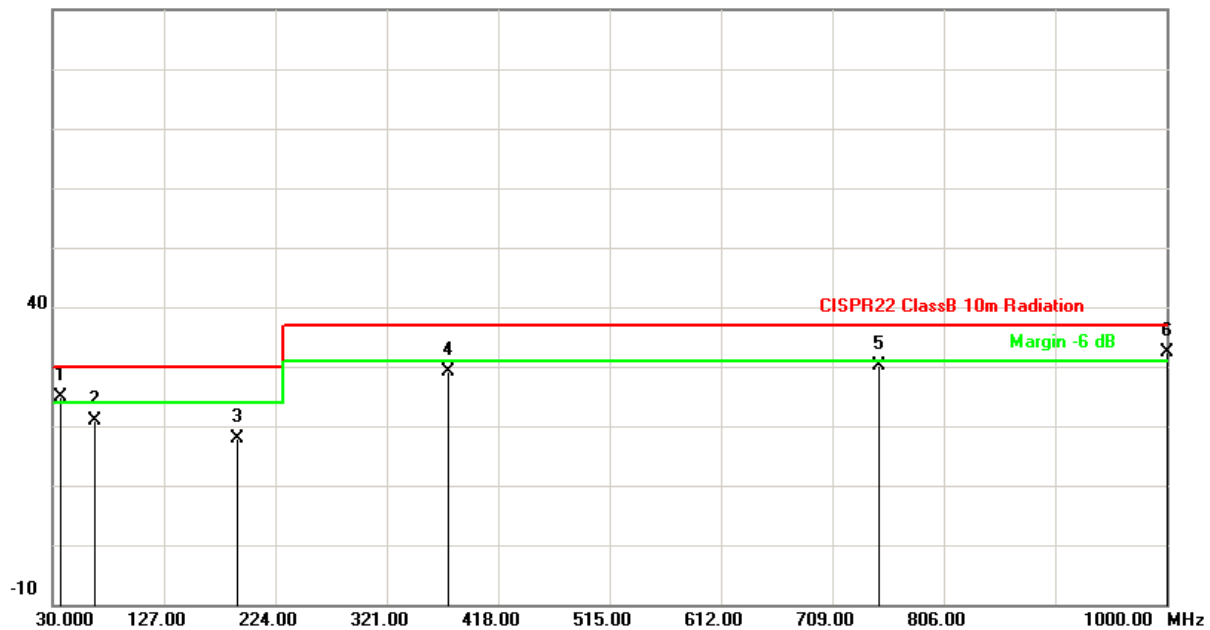

| No. | Frequency (MHz) | Reading Level (dBuV) | Correct Factor (dB) | Measurement (dBuV) | Limit (dBuV) | Margin (dB) | Detector | Antenna Height (cm) | Table Degree (degree) |
|-----|-----------------|----------------------|---------------------|--------------------|--------------|-------------|----------|---------------------|-----------------------|
| 1 | 37.4970 | 49.19 | -24.19 | 25.00 | 30.00 | -5.00 | QP | 400 | 206 |
| 2 | 67.2610 | 47.18 | -26.39 | 20.79 | 30.00 | -9.21 | QP | 400 | 325 |
| 3 | 191.2260 | 47.95 | -30.15 | 17.80 | 30.00 | -12.20 | QP | 400 | 0 |
| 4 | 375.0080 | 54.01 | -24.94 | 29.07 | 37.00 | -7.93 | QP | 221 | 229 |
| 5 | 750.0100 | 46.72 | -16.68 | 30.04 | 37.00 | -6.96 | QP | 145 | 154 |
| 6 | 1000.0000 | 46.25 | -13.81 | 32.44 | 37.00 | -4.56 | QP | 134 | 308 |

Remark:

1. QP = Quasi Peak
2. Correction Factor = Antenna factor + Cable loss (Antenna to preamplifier) - preamplifier Gain + Cable loss (preamplifier to receiver)
3. Measurement Value = Reading Level + Correct Factor
4. Margin Level = Measurement Value - Limit Value



| | | | |
|---------------------------------|--------------|------------------------|----------|
| Test Voltage | 230Vac, 50Hz | Frequency Range | 1 – 6GHz |
| Environmental Conditions | 18°C, 57% RH | 6dB Bandwidth | 1MHz |
| Test Date | 2015/12/22 | Test Distance | 3m |
| Tested by | Evan Cheng | Polarization | Vertical |
| Test Mode | A | | |

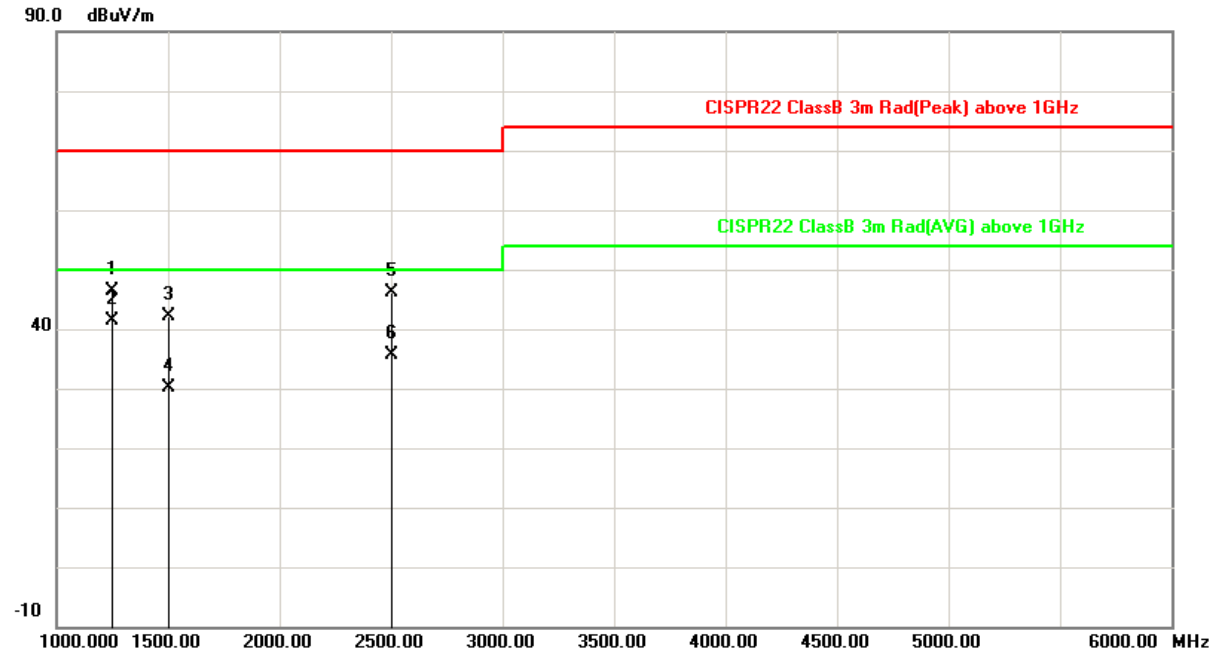

| No. | Frequency (MHz) | Reading Level (dBuV) | Correct Factor (dB) | Measurement (dBuV) | Limit (dBuV) | Margin (dB) | Detector | Antenna Height (cm) | Table Degree (degree) |
|-----|-----------------|----------------------|---------------------|--------------------|--------------|-------------|----------|---------------------|-----------------------|
| 1 | 1250.000 | 59.03 | -12.68 | 46.35 | 70.00 | -23.65 | peak | 100 | 200 |
| 2 | 1250.000 | 54.03 | -12.68 | 41.35 | 50.00 | -8.65 | AVG | 100 | 200 |
| 3 | 1500.000 | 52.91 | -10.87 | 42.04 | 70.00 | -27.96 | peak | 100 | 100 |
| 4 | 1500.000 | 40.90 | -10.87 | 30.03 | 50.00 | -19.97 | AVG | 100 | 100 |
| 5 | 2500.000 | 52.23 | -5.99 | 46.24 | 70.00 | -23.76 | peak | 100 | 175 |
| 6 | 2500.000 | 41.56 | -5.99 | 35.57 | 50.00 | -14.43 | AVG | 100 | 175 |

Remark: 1. peak = Peak, AVG = Average
 2. Correction Factor = Antenna factor + Cable loss (Antenna to preamplifier) - preamplifier Gain + Cable loss (preamplifier to receiver)
 3. Measurement Value = Reading Level + Correct Factor
 4. Margin Level = Measurement Value - Limit Value



| | | | |
|---------------------------------|--------------|------------------------|------------|
| Test Voltage | 230Vac, 50Hz | Frequency Range | 1 – 6GHz |
| Environmental Conditions | 18°C, 57% RH | 6dB Bandwidth | 1MHz |
| Test Date | 2015/12/22 | Test Distance | 3m |
| Tested by | Evan Cheng | Polarization | Horizontal |
| Test Mode | A | | |

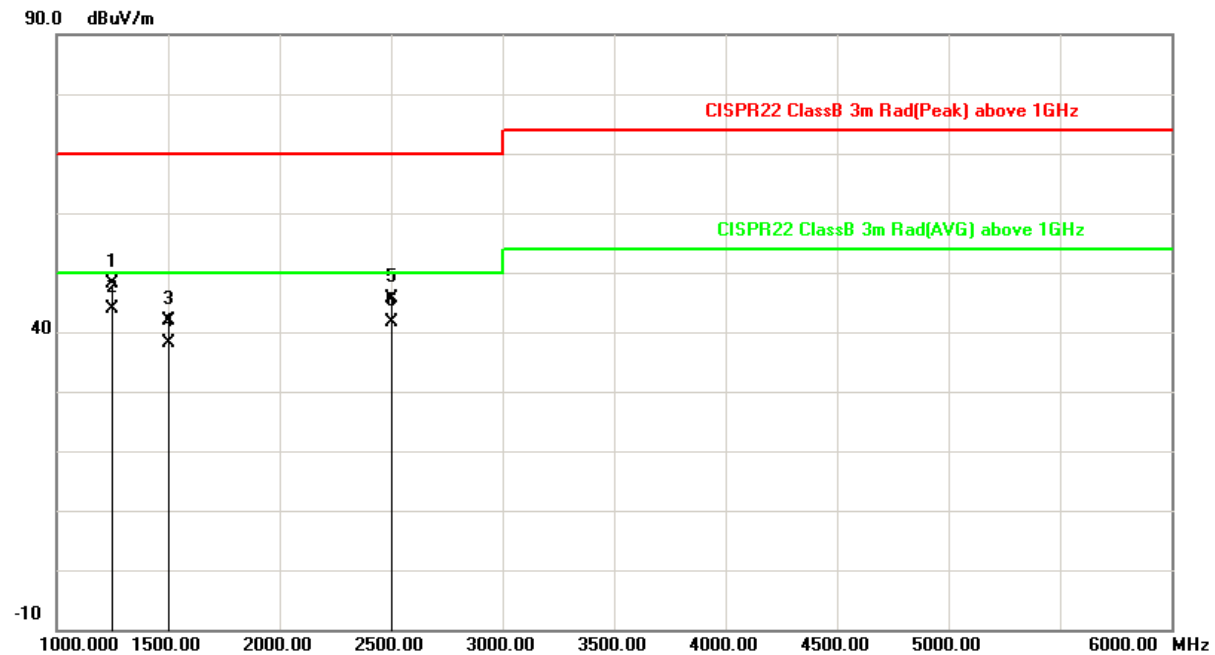

| No. | Frequency (MHz) | Reading Level (dBuV) | Correct Factor (dB) | Measurement (dBuV) | Limit (dBuV) | Margin (dB) | Detector | Antenna Height (cm) | Table Degree (degree) |
|-----|-----------------|----------------------|---------------------|--------------------|--------------|-------------|----------|---------------------|-----------------------|
| 1 | 1250.000 | 60.89 | -12.68 | 48.21 | 70.00 | -21.79 | peak | 100 | 220 |
| 2 | 1250.000 | 56.54 | -12.68 | 43.86 | 50.00 | -6.14 | AVG | 100 | 220 |
| 3 | 1500.000 | 52.73 | -10.87 | 41.86 | 70.00 | -28.14 | peak | 100 | 100 |
| 4 | 1500.000 | 48.91 | -10.87 | 38.04 | 50.00 | -11.96 | AVG | 100 | 100 |
| 5 | 2500.000 | 51.63 | -5.99 | 45.64 | 70.00 | -24.36 | peak | 100 | 180 |
| 6 | 2500.000 | 47.66 | -5.99 | 41.67 | 50.00 | -8.33 | AVG | 100 | 180 |

Remark:

1. peak = Peak, AVG = Average
2. Correction Factor = Antenna factor + Cable loss (Antenna to preamplifier) - preamplifier Gain + Cable loss (preamplifier to receiver)
3. Measurement Value = Reading Level + Correct Factor
4. Margin Level = Measurement Value - Limit Value



| | | | |
|---------------------------------|--------------|------------------------|----------|
| Test Voltage | 230Vac, 50Hz | Frequency Range | 1 – 6GHz |
| Environmental Conditions | 18°C, 57% RH | 6dB Bandwidth | 1MHz |
| Test Date | 2015/12/22 | Test Distance | 3m |
| Tested by | Evan Cheng | Polarization | Vertical |
| Test Mode | B | | |

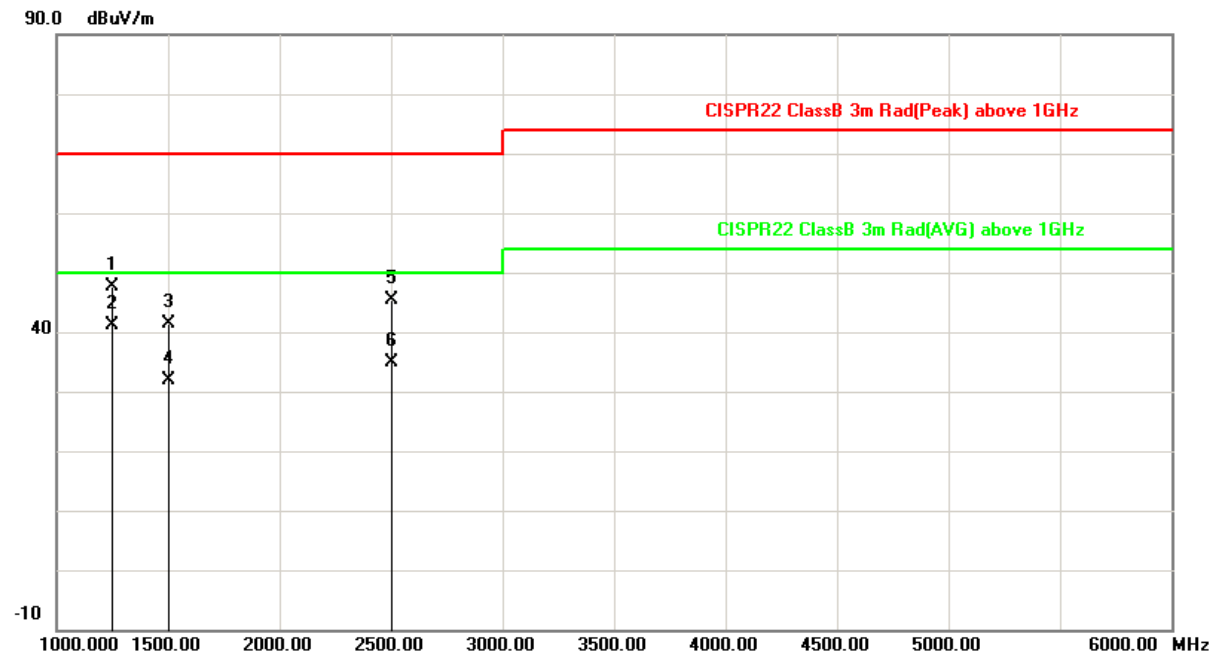

| No. | Frequency (MHz) | Reading Level (dBuV) | Correct Factor (dB) | Measurement (dBuV) | Limit (dBuV) | Margin (dB) | Detector | Antenna Height (cm) | Table Degree (degree) |
|-----|-----------------|----------------------|---------------------|--------------------|--------------|-------------|----------|---------------------|-----------------------|
| 1 | 1250.000 | 60.24 | -12.68 | 47.56 | 70.00 | -22.44 | peak | 100 | 210 |
| 2 | 1250.000 | 53.74 | -12.68 | 41.06 | 50.00 | -8.94 | AVG | 100 | 210 |
| 3 | 1500.000 | 52.16 | -10.87 | 41.29 | 70.00 | -28.71 | peak | 100 | 100 |
| 4 | 1500.000 | 42.67 | -10.87 | 31.80 | 50.00 | -18.20 | AVG | 100 | 100 |
| 5 | 2500.000 | 51.41 | -5.99 | 45.42 | 70.00 | -24.58 | peak | 100 | 180 |
| 6 | 2500.000 | 40.98 | -5.99 | 34.99 | 50.00 | -15.01 | AVG | 100 | 180 |

Remark: 1. peak = Peak, AVG = Average
 2. Correction Factor = Antenna factor + Cable loss (Antenna to preamplifier) - preamplifier Gain + Cable loss (preamplifier to receiver)
 3. Measurement Value = Reading Level + Correct Factor
 4. Margin Level = Measurement Value - Limit Value



| | | | |
|---------------------------------|--------------|------------------------|------------|
| Test Voltage | 230Vac, 50Hz | Frequency Range | 1 – 6GHz |
| Environmental Conditions | 18°C, 57% RH | 6dB Bandwidth | 1MHz |
| Test Date | 2015/12/22 | Test Distance | 3m |
| Tested by | Evan Cheng | Polarization | Horizontal |
| Test Mode | B | | |

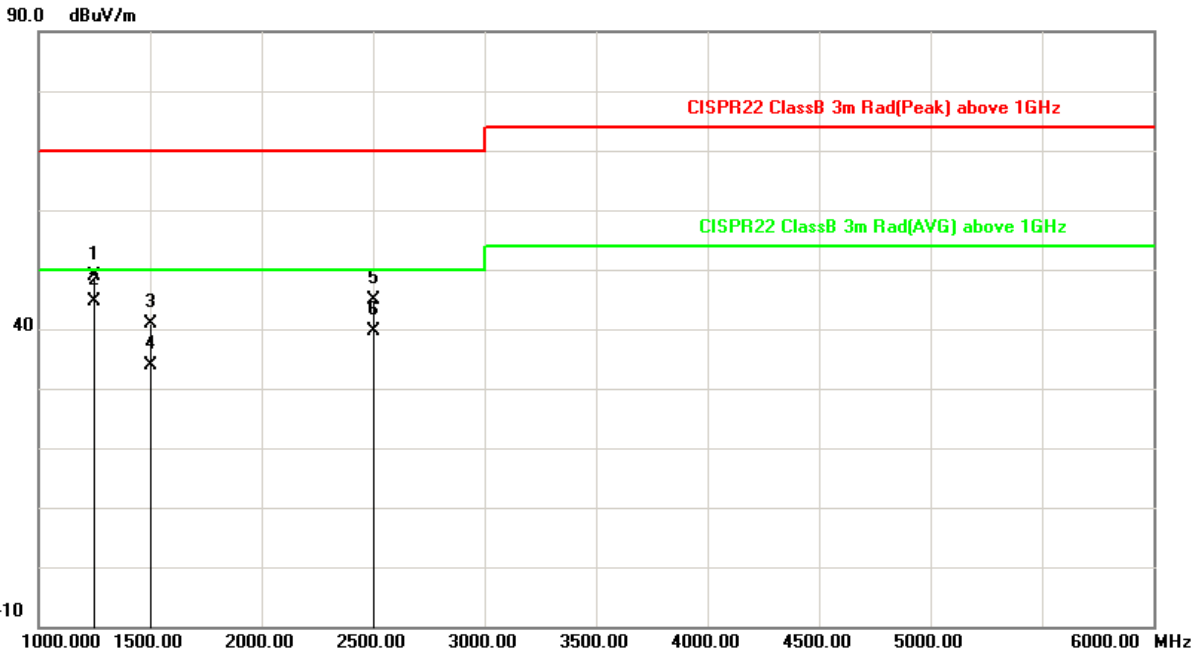

| No. | Frequency (MHz) | Reading Level (dBuV) | Correct Factor (dB) | Measurement (dBuV) | Limit (dBuV) | Margin (dB) | Detector | Antenna Height (cm) | Table Degree (degree) |
|-----|-----------------|----------------------|---------------------|--------------------|--------------|-------------|----------|---------------------|-----------------------|
| 1 | 1250.000 | 61.58 | -12.68 | 48.90 | 70.00 | -21.10 | peak | 100 | 220 |
| 2 | 1250.000 | 57.34 | -12.68 | 44.66 | 50.00 | -5.34 | AVG | 100 | 220 |
| 3 | 1500.000 | 51.69 | -10.87 | 40.82 | 70.00 | -29.18 | peak | 100 | 95 |
| 4 | 1500.000 | 44.84 | -10.87 | 33.97 | 50.00 | -16.03 | AVG | 100 | 95 |
| 5 | 2500.000 | 50.76 | -5.99 | 44.77 | 70.00 | -25.23 | peak | 100 | 180 |
| 6 | 2500.000 | 45.56 | -5.99 | 39.57 | 50.00 | -10.43 | AVG | 100 | 180 |

Remark: 1. peak = Peak, AVG = Average
 2. Correction Factor = Antenna factor + Cable loss (Antenna to preamplifier) - preamplifier Gain + Cable loss (preamplifier to receiver)
 3. Measurement Value = Reading Level + Correct Factor
 4. Margin Level = Measurement Value - Limit Value



| | | | |
|---------------------------------|--------------|------------------------|----------|
| Test Voltage | 48Vdc (POE) | Frequency Range | 1 – 6GHz |
| Environmental Conditions | 18°C, 57% RH | 6dB Bandwidth | 1MHz |
| Test Date | 2015/12/22 | Test Distance | 3m |
| Tested by | Evan Cheng | Polarization | Vertical |
| Test Mode | C | | |

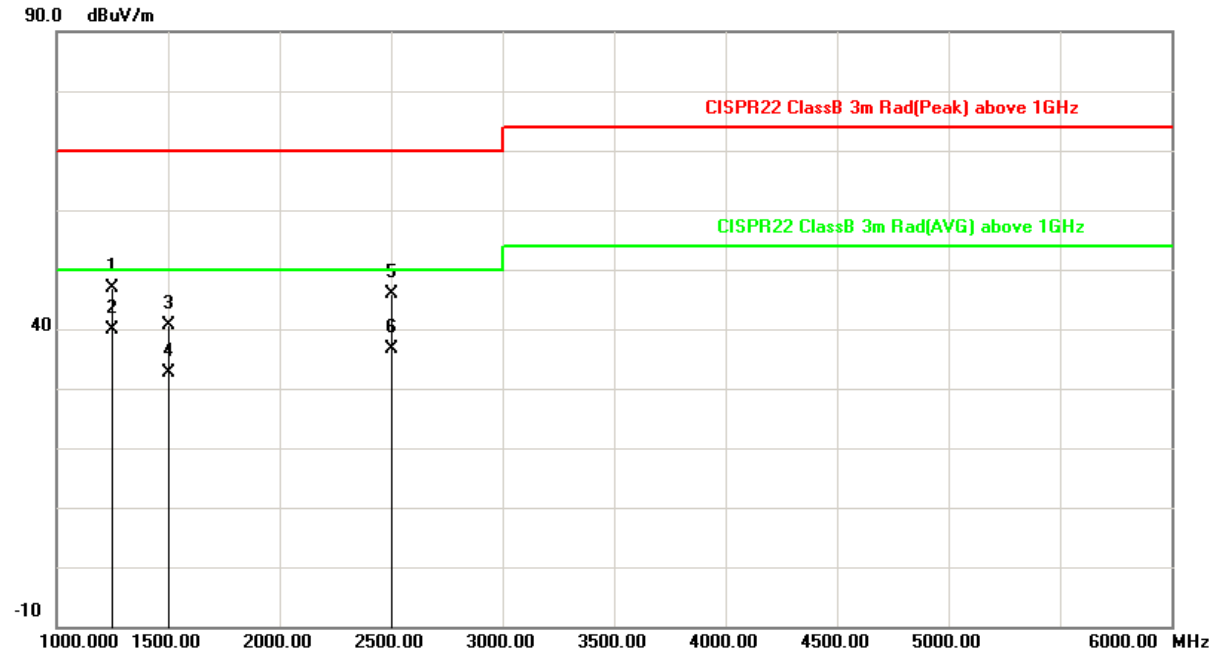

| No. | Frequency (MHz) | Reading Level (dBuV) | Correct Factor (dB) | Measurement (dBuV) | Limit (dBuV) | Margin (dB) | Detector | Antenna Height (cm) | Table Degree (degree) |
|-----|-----------------|----------------------|---------------------|--------------------|--------------|-------------|----------|---------------------|-----------------------|
| 1 | 1250.000 | 59.63 | -12.68 | 46.95 | 70.00 | -23.05 | peak | 100 | 210 |
| 2 | 1250.000 | 52.66 | -12.68 | 39.98 | 50.00 | -10.02 | AVG | 100 | 210 |
| 3 | 1500.000 | 51.43 | -10.87 | 40.56 | 70.00 | -29.44 | peak | 100 | 100 |
| 4 | 1500.000 | 43.55 | -10.87 | 32.68 | 50.00 | -17.32 | AVG | 100 | 100 |
| 5 | 2500.000 | 51.83 | -5.99 | 45.84 | 70.00 | -24.16 | peak | 100 | 180 |
| 6 | 2500.000 | 42.69 | -5.99 | 36.70 | 50.00 | -13.30 | AVG | 100 | 180 |

Remark: 1. peak = Peak, AVG = Average
 2. Correction Factor = Antenna factor + Cable loss (Antenna to preamplifier) - preamplifier Gain + Cable loss (preamplifier to receiver)
 3. Measurement Value = Reading Level + Correct Factor
 4. Margin Level = Measurement Value - Limit Value



| | | | |
|---------------------------------|--------------|------------------------|------------|
| Test Voltage | 48Vdc (POE) | Frequency Range | 1 – 6GHz |
| Environmental Conditions | 18°C, 57% RH | 6dB Bandwidth | 1MHz |
| Test Date | 2015/12/22 | Test Distance | 3m |
| Tested by | Evan Cheng | Polarization | Horizontal |
| Test Mode | C | | |

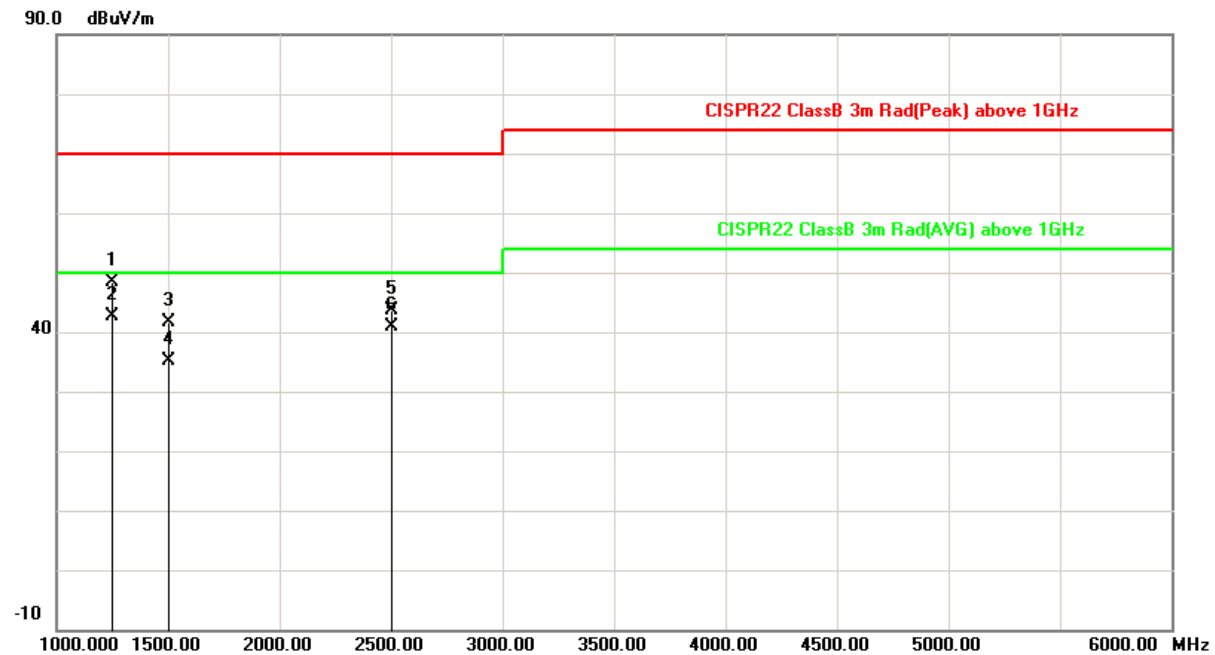

| No. | Frequency (MHz) | Reading Level (dBuV) | Correct Factor (dB) | Measurement (dBuV) | Limit (dBuV) | Margin (dB) | Detector | Antenna Height (cm) | Table Degree (degree) |
|-----|-----------------|----------------------|---------------------|--------------------|--------------|-------------|----------|---------------------|-----------------------|
| 1 | 1250.000 | 61.13 | -12.68 | 48.45 | 70.00 | -21.55 | peak | 100 | 220 |
| 2 | 1250.000 | 55.34 | -12.68 | 42.66 | 50.00 | -7.34 | AVG | 100 | 220 |
| 3 | 1500.000 | 52.43 | -10.87 | 41.56 | 70.00 | -28.44 | peak | 100 | 95 |
| 4 | 1500.000 | 45.95 | -10.87 | 35.08 | 50.00 | -14.92 | AVG | 100 | 95 |
| 5 | 2500.000 | 49.59 | -5.99 | 43.60 | 70.00 | -26.40 | peak | 100 | 180 |
| 6 | 2500.000 | 46.76 | -5.99 | 40.77 | 50.00 | -9.23 | AVG | 100 | 180 |

Remark: 1. peak = Peak, AVG = Average
 2. Correction Factor = Antenna factor + Cable loss (Antenna to preamplifier) - preamplifier Gain + Cable loss (preamplifier to receiver)
 3. Measurement Value = Reading Level + Correct Factor
 4. Margin Level = Measurement Value - Limit Value

4.3.7 Photographs of Test Configuration

Radiated Emission Test (30MHz~1GHz) Test Mode A



Radiated Emission Test (30MHz~1GHz)

Test Mode B



**Radiated Emission Test (30MHz~1GHz)
Test Mode C**



**Radiated Emission Test (Above 1GHz)
Test Mode A**

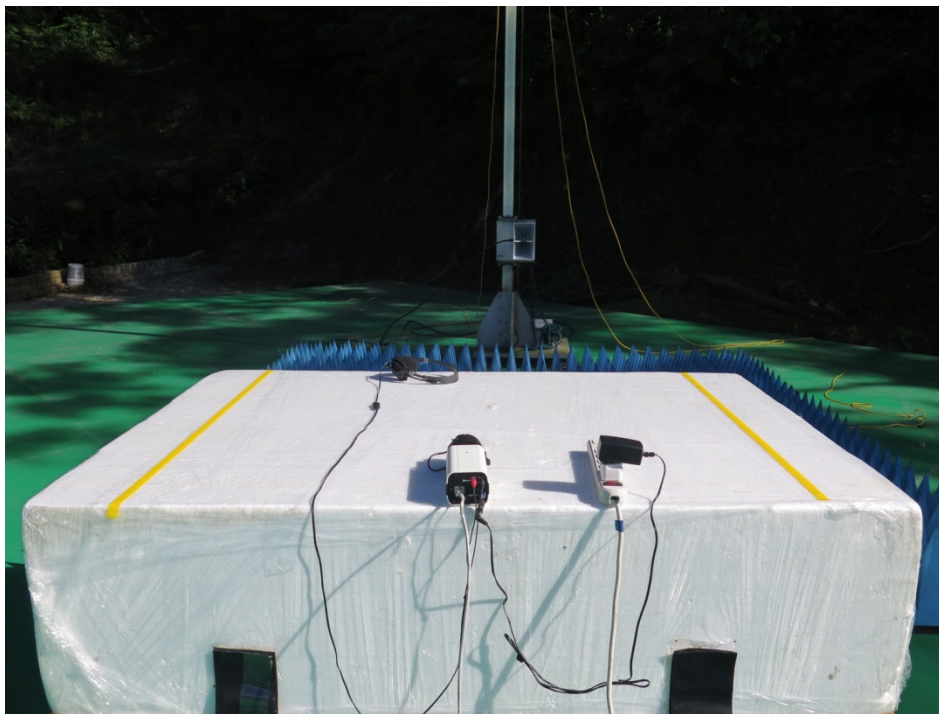
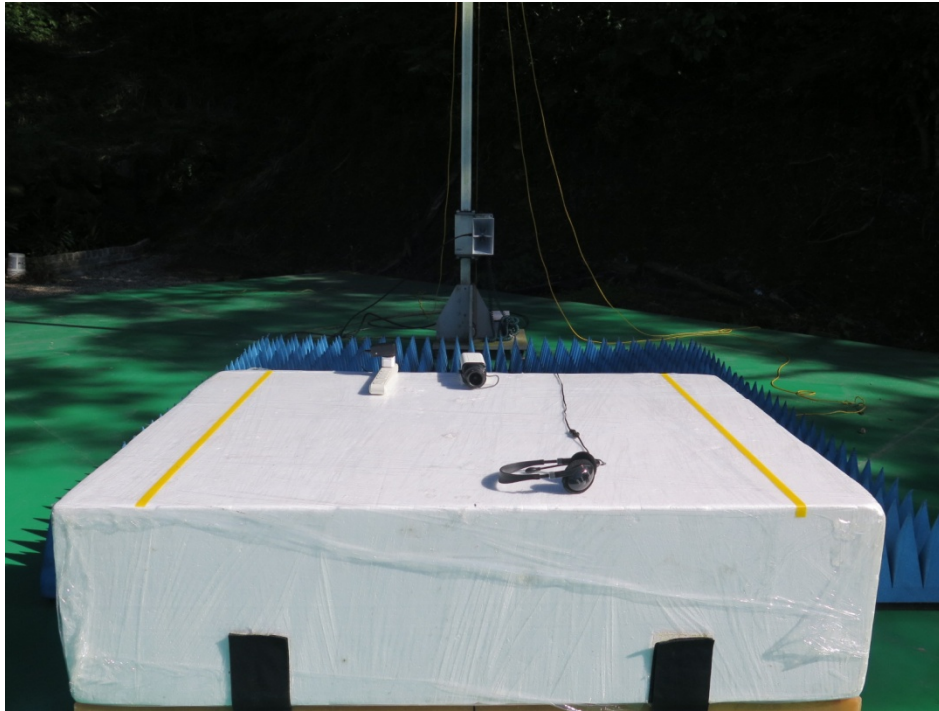

**Radiated Emission Test (Above 1GHz)
Test Mode B**

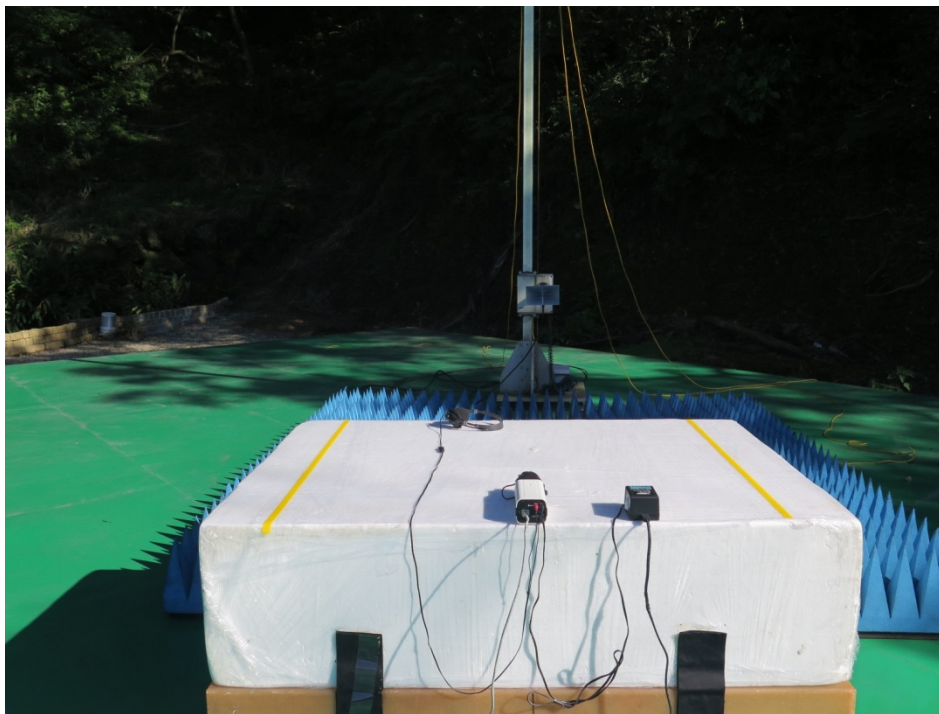
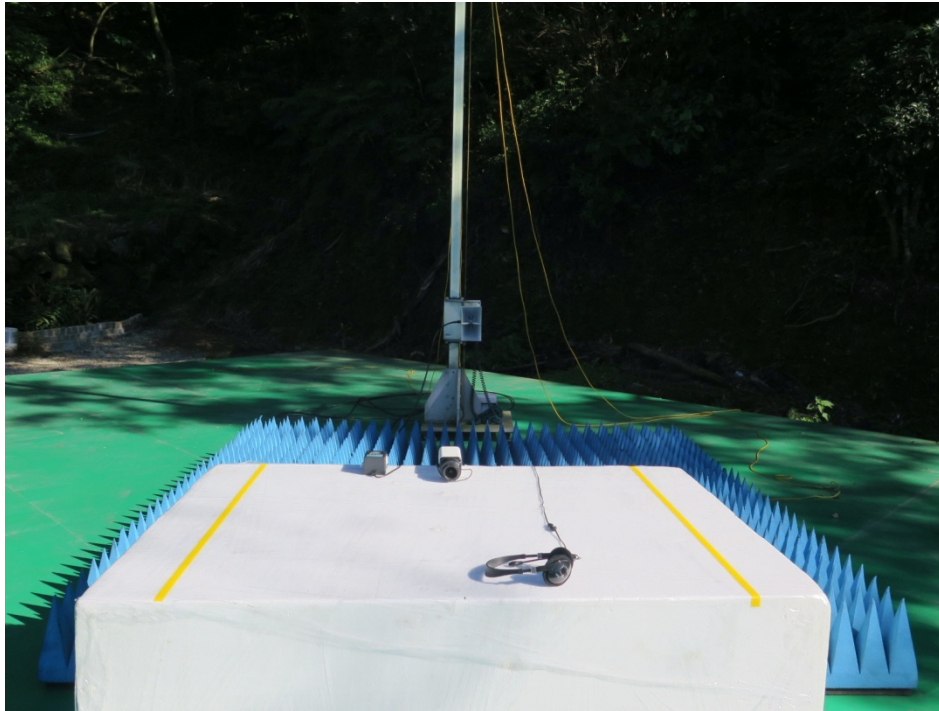

**Radiated Emission Test (Above 1GHz)
Test Mode C**

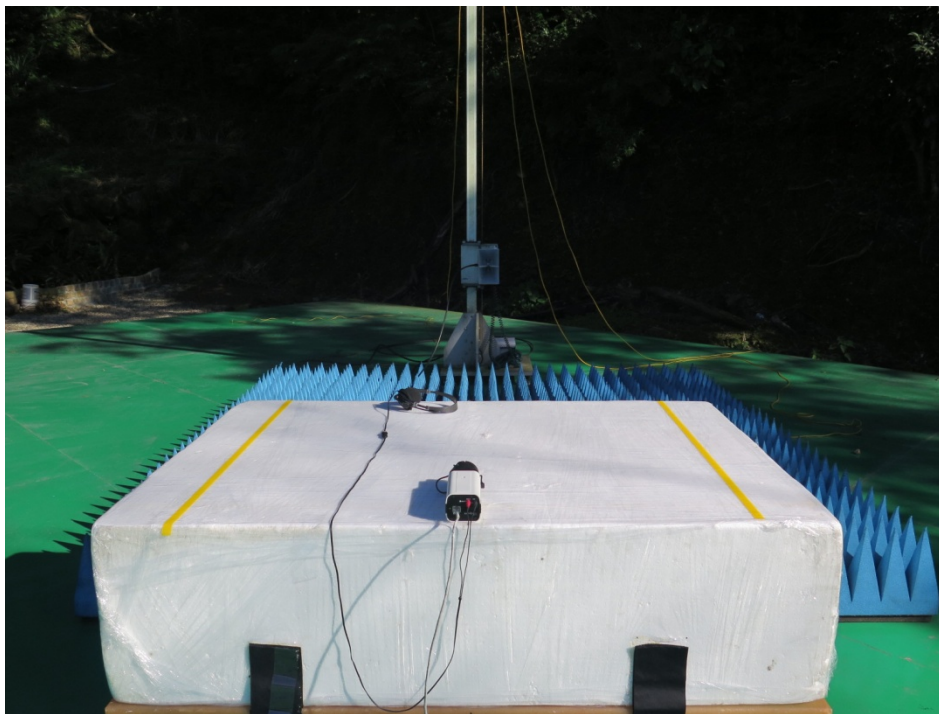
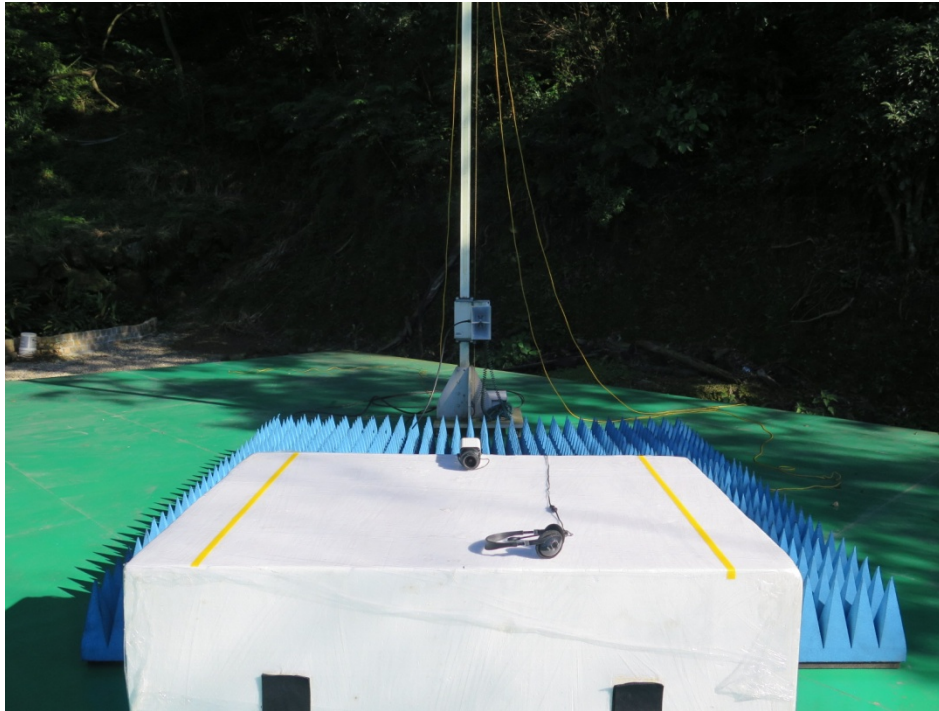

4.4 Harmonics Current Measurement

4.4.1 Limits of Harmonics Current Measurement

The limits ensure that harmonic disturbance levels do not exceed the compatibility levels defined in IEC 61000-3-2.

| Limits for Class A equipment | |
|------------------------------|--------------------------------------|
| Harmonics Order n | Max. permissible harmonics current A |
| Odd harmonics | |
| 3 | 2.30 |
| 5 | 1.14 |
| 7 | 0.77 |
| 9 | 0.40 |
| 11 | 0.33 |
| 13 | 0.21 |
| 15<=n<=39 | 0.15x15/n |
| Even harmonics | |
| 2 | 1.08 |
| 4 | 0.43 |
| 6 | 0.30 |
| 8<=n<=40 | 0.23x8/n |

| Limits for Class D equipment | | |
|------------------------------|--|--------------------------------------|
| Harmonics Order n | Max. permissible harmonics current per watt mA/W | Max. permissible harmonics current A |
| Odd Harmonics only | | |
| 3 | 3.4 | 2.30 |
| 5 | 1.9 | 1.14 |
| 7 | 1.0 | 0.77 |
| 9 | 0.5 | 0.40 |
| 11 | 0.35 | 0.33 |
| 13 | 0.30 | 0.21 |
| 15<=n<=39 | 3.85/n | 0.15x15/n |

- Note:** 1. Class A and Class D are classified according to item section 5 of EN 61000-3-2.
 2. According to section 7 of EN 61000-3-2, the above limits for all equipment except for lighting equipment having an active input power > 75 W and no limits apply for equipment with an active input power up to and including 75 W.

4.4.2 Test Instrument

| Item | Equipment | Manufacturer | Model | Meter No. | Calibration Date |
|------|------------------------------|--------------|-------------|-------------|------------------|
| 1 | Harmonics & Flicker Analyser | EMC PARTNER | HAR-1000-1P | CT-1-090(1) | Dec. 09, 2015 |
| 2 | Power Source | EMC PARTNER | PS3-1 | CT-1-090a1 | Dec. 09, 2015 |

- Note:** 1. The calibration interval of the above test instruments is 12 months.

4.4.3 Test Procedure

The EUT was placed on the top of a wooden table 0.8 meter above the ground and operated to produce the maximum harmonic under normal operating conditions for each successive harmonic component in turn.

The classification of EUT is according to section 5 of EN 61000-3-2.

The EUT classified as follows:

Class A:

- Balanced three-phase equipment;
- Household appliances excluding equipment identified as Class D;
- Tools excluding portable tools;
- Dimmers for incandescent lamps;
- Audio equipment.

Equipment not specified in one of the three other classes should be considered as Class A equipment.

Note 1: Equipment that can be shown to have a significant effect on the supply system may be reclassified in a future edition of the standard. Factors to be taken into account include:

- Number in use;
- Duration of use;
- Simultaneity of use;
- Power consumption;
- Harmonic spectrum, including phase.

Class B:

- Portable tools;
- Arc welding equipment, which is not professional equipment.

Class C:

- Lighting equipment;

Class D:

Equipment having a specified power according to 6.2.2 less than or equal to 600W, of the following types:

- Personal computers and personal computer monitors;
- Television receivers.

4.4.4 Deviation from Test Standard

No deviation

4.4.5 Test Setup

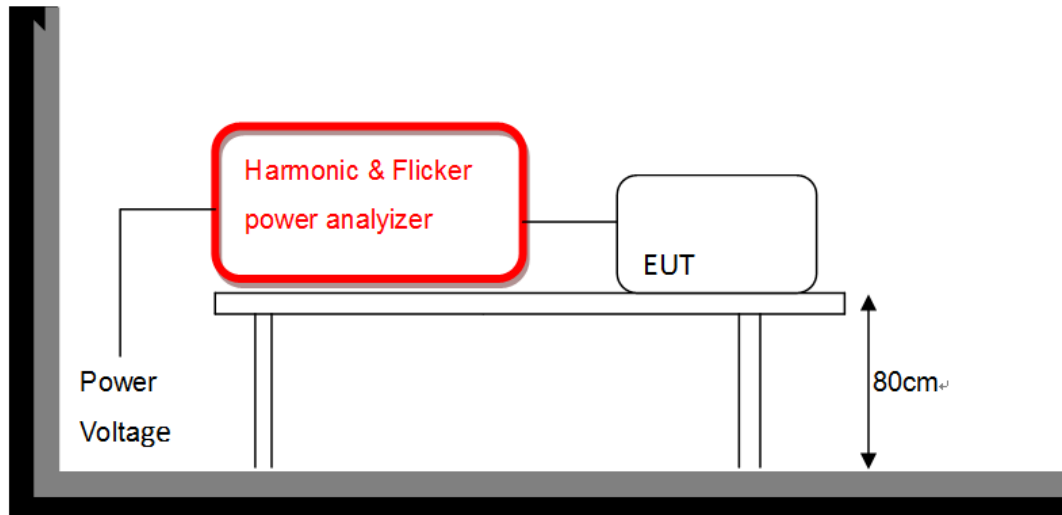

4.4.6 Test Result

| | | | |
|---------------------------------|-------------------------|--------------------------|--------------|
| Supply Voltage / Ampere | 230.1 Vrms / 0.061 Arms | Test Date | 2015/12/23 |
| Test Duration | 5 min | Power Consumption | 4.823W |
| Power Frequency | 49.935Hz | Power Factor | 0.345 |
| Environmental Conditions | 22°C, 59% RH | Tested by | Guanwei Liao |
| Test Mode | A | | |

Note:

1. Limits are not specified for equipment with a rated power of 75W or less (other than lighting equipment).
2. According to EN 61000-3-2 the manufacturer shall specify the power of the apparatus. This value shall be used for establishing limits. The specified power shall be within +/-10% of the measured power.

| | | | |
|---------------------------------|-------------------------|--------------------------|--------------|
| Supply Voltage / Ampere | 230.1 Vrms / 0.098 Arms | Test Date | 2015/12/23 |
| Test Duration | 5 min | Power Consumption | 8.590W |
| Power Frequency | 49.935Hz | Power Factor | 0.382 |
| Environmental Conditions | 22°C, 59% RH | Tested by | Guanwei Liao |
| Test Mode | B | | |

Note:

1. Limits are not specified for equipment with a rated power of 75W or less (other than lighting equipment).
2. According to EN 61000-3-2 the manufacturer shall specify the power of the apparatus. This value shall be used for establishing limits. The specified power shall be within +/-10% of the measured power.

4.4.7 Photographs of Test Configuration

Test Mode A



Test Mode B

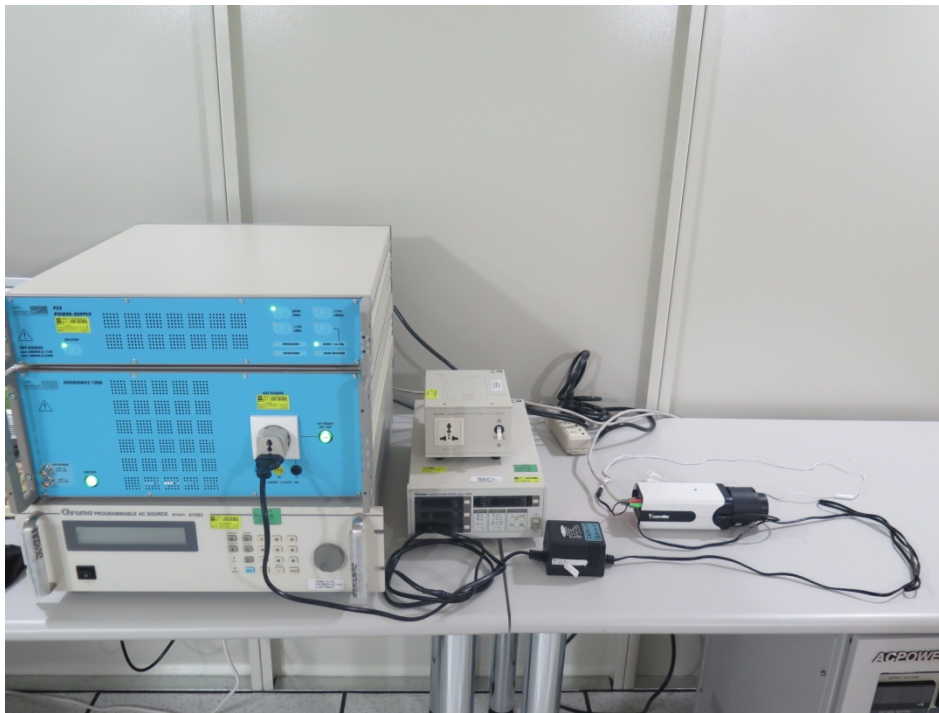

4.5 Voltage Fluctuation and Flicker Measurement

4.5.1 Limit for Voltage Function and Flicker Measurement

| Tests Item | Limits | Remark |
|----------------------|-------------------------------|--|
| | IEC/EN 61000-3-3 | |
| P _{st} | 1.0, T _p = 10 min. | P _{st} means short-term flicker |
| P _{lt} | 0.65, T _p =2 hr. | P _{lt} means long-term flicker |
| D _c (%) | 3.3% | d _c means relative steady-state voltage change |
| D _{max} (%) | 4% | d _{max} means maximum relative voltage change. |
| T _d (t) | 3.3% / 500 ms | T _d t means maximum time that d _t exceeds 3 %. |

4.5.2 Test Instrument

| Item | Equipment | Manufacturer | Model | Meter No. | Calibration Date |
|------|------------------------------|--------------|-------------|-------------|------------------|
| 1 | Harmonics & Flicker Analyser | EMC PARTNER | HAR-1000-1P | CT-1-090(1) | Dec. 09, 2015 |
| 2 | Power Source | EMC PARTNER | PS3-1 | CT-1-090a1 | Dec. 09, 2015 |

Note: 1. The calibration interval of the above test instruments is 12 months.

4.5.3 Test Procedure

The EUT was placed on the top of a wooden table 0.8 meter above the ground and operated to produce the most unfavorable sequence of voltage changes under normal operating condition.

During the flick measurement, the measure time shall include that part of whole operation cycle in which the EUT produce the most unfavorable sequence of voltage changes. The observation period for short-term flicker indicator is 10 min and the observation period for long-term flicker indicator is 2 hours.

4.5.4 Deviation from Test Standard

No deviation

4.5.5 Test Setup

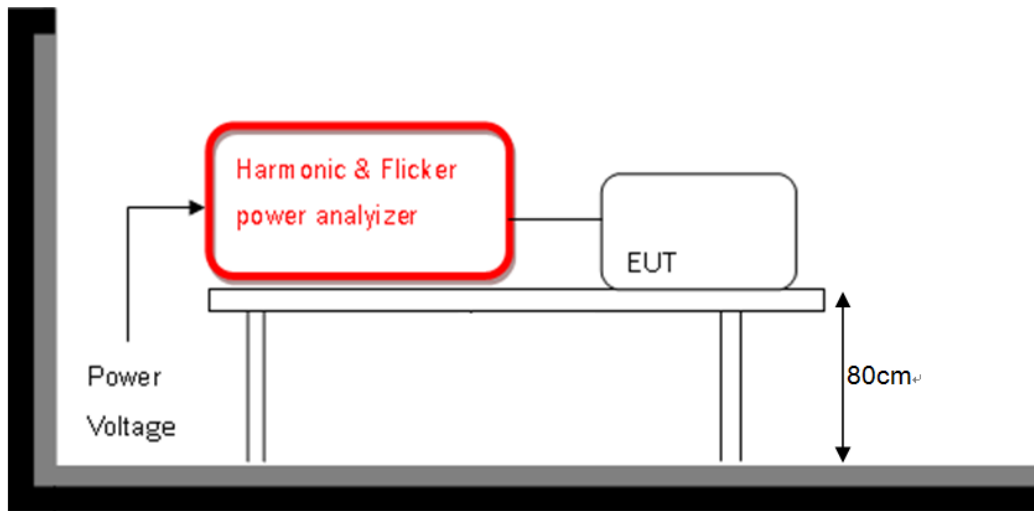

4.5.6 Test Result

| | | | |
|--------------------------------|----------------------------|---------------------------------|--------------|
| Supply Voltage / Ampere | 230.1 Vrms / 0.098 Arms | Test Date | 2015/12/23 |
| Observation (Tp) | 30 min | Environmental Conditions | 22°C, 59% RH |
| Power Frequency | 49.935Hz | Tested by | Guanwei Liao |
| Test Mode | A | | |

| Test Parameter | Measurement Value | Test Limit | Remarks |
|----------------------|-------------------|------------|---------|
| P _{st} | 0.07 | 1.00 | Pass |
| P _{lt} | 0.07 | 0.65 | Pass |
| T _{dt} (ms) | 0.00 | 500 | Pass |
| d _{max} (%) | 0.00 | 4% | Pass |
| dc (%) | 0.03 | 3.3% | Pass |

- Note:**
1. P_{st} means short-term flicker indicator.
 2. P_{lt} means long-term flicker indicator.
 3. T_{dt} means maximum time that dt exceeds 3.3 %.
 4. d_{max} means maximum relative voltage change.
 5. dc means relative steady-state voltage change.

| | | | |
|--------------------------------|----------------------------|---------------------------------|--------------|
| Supply Voltage / Ampere | 230.1 Vrms / 0.098 Arms | Test Date | 2015/12/23 |
| Observation (Tp) | 30 min | Environmental Conditions | 22°C, 59% RH |
| Power Frequency | 49.922Hz | Tested by | Guanwei Liao |
| Test Mode | B | | |

| Test Parameter | Measurement Value | Test Limit | Remarks |
|----------------------|-------------------|------------|---------|
| P _{st} | 0.07 | 1.00 | Pass |
| P _{lt} | 0.07 | 0.65 | Pass |
| T _{dt} (ms) | 0.00 | 500 | Pass |
| d _{max} (%) | 0.00 | 4% | Pass |
| dc (%) | 0.03 | 3.3% | Pass |

- Note:**
1. P_{st} means short-term flicker indicator.
 2. P_{lt} means long-term flicker indicator.
 3. T_{dt} means maximum time that dt exceeds 3.3 %.
 4. d_{max} means maximum relative voltage change.
 5. dc means relative steady-state voltage change.

4.5.7 Photographs of Test Configuration

Test Mode A



Test Mode B

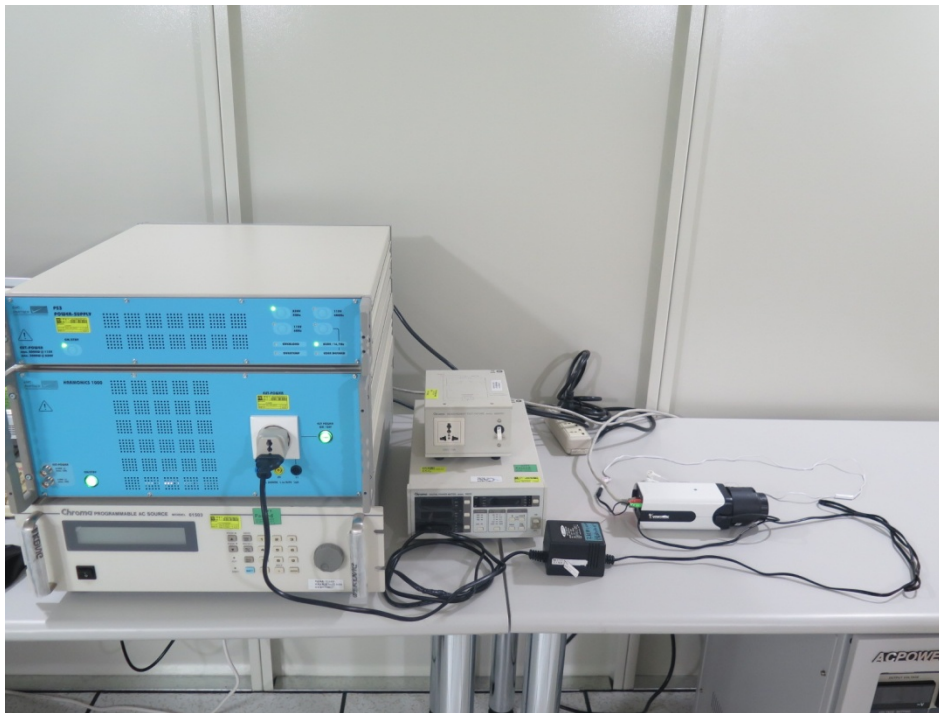

5.2 Performance Criteria

According to Clause 7 of EN 55024 standard, the general performance criteria as following:

| | |
|-------------------|---|
| Criteria A | The equipment shall continue to operate as intended without operator intervention. No degradation of performance or loss of function is allowed below a performance level specified by the manufacturer when the equipment is used as intended. The performance level may be replaced by a permissible loss of performance. If the minimum performance level or the permissible performance loss is not specified by the manufacturer, then either of these may be derived from the product description and documentation, and by what the user may reasonably expect from the equipment if used as intended. |
| Criteria B | After the test, the equipment shall continue to operate as intended without operator intervention. No degradation of performance or loss of function is allowed, after the application of the phenomenon below a performance level specified by the manufacturer, when the equipment is used as intended. The performance level may be replaced by a permissible loss of performance. During the test, degradation of performance is allowed. However, no change of operating state if stored data is allowed to persist after the test. If the minimum performance level (or the permissible performance loss) is not specified by the manufacturer, then either of these may be derived from the product description and documentation, and by what the user may reasonably expect from the equipment if used as intended. |
| Criteria C | Loss of function is allowed, provided the function is self-recoverable, or can be restored by the operation of the controls by the user in accordance with the manufacturer's instructions. Functions, and/or information stored in non-volatile memory, or protected by a battery backup, shall not be lost. |

5.3 Electrostatic Discharge (ESD)

5.3.1 Test Specification

| | |
|----------------------------|--|
| Standard | IEC/EN 61000-4-2 |
| Discharge Impedance | 330 ohm / 150 pF |
| Discharge Voltage | Air Discharge: $\pm 2, \pm 4, \pm 8$ kV (Direct) Contact Discharge: $\pm 2, \pm 4$ kV (Direct/Indirect) |
| Number of Discharge | Air: Minimum 10 times at each point. Contact: Minimum 25 times at each point and minimum 200 times in total |
| Discharge Mode | Single Discharge |
| Discharge Period | 1 second minimum |

5.3.2 Test Instrument

| Item | Equipment | Manufacturer | Model | Meter No. | Calibration Date |
|------|----------------------------------|--------------|-----------------------|------------|------------------|
| 1 | ESD Simulator/ Discharge Gun | NoiseKen | ESS-B3011 | CT-1-089 | Nov. 04, 2015 |
| 2 | Digital Thermo-Hygro Meter | N/A | HTC-8 | CT-2-047 | Apr. 09, 2015 |
| 3 | Atmosphere pressure meter | N/A | Kat.Nr.45.10 00.01 | CT-2-052-1 | Aug. 04, 2015 |

Note: 1. The calibration interval of the above test instruments is 12 months.

5.3.3 Test Procedure

The test generator necessary to perform direct and indirect application of discharge to the EUT in following methods:

a. Contact discharges to the conductive surface and coupling planes:

The EUT shall be exposed to at least 200 discharges, 100 each at positive and negative polarity, at a minimum of four test points. One of the test points shall be subjected to at least 50 indirect discharges to the center of the front edge of the horizontal coupling plane (HCP). The remaining three test points shall be each receives at least 50 direct contact discharges. If no direct contact test points are available, shall be at least 200 indirect discharges applied in the indirect mode. Test shall be performed at a maximum repetition rate of one discharge per second.

Vertical Coupling Plane (VCP):

The coupling plane, of dimensions 0.5 m × 0.5 m, is placed parallel to, and positioned at a distance 0.1 m from, the EUT, with the discharge electrode touching the coupling plane. The four faces of the EUT will be performed with electrostatic discharge.

Horizontal Coupling Plane (HCP):

The coupling plane, of dimensions 1.6 m × 0.8 m, is placed under the EUT. The generator shall be positioned vertically a distance of 0.1 m from the EUT, with the discharge electrode touching the coupling plane. The four faces of the EUT will be performed with electrostatic discharge.

b. Air discharge at apertures and slots and insulating surface:

On those parts of the EUT where it is not possible to perform contact discharge testing, the equipment should be investigated to identify user accessible points where breakdown may occur. Such points are tested using the air discharge method. This investigation should be restricted to those area normally handled by the user. A minimum 10 single air discharges shall be applied to the selected test point for each such area.

5.3.4 Deviation from Test Standard

No deviation

5.3.5 Test Setup

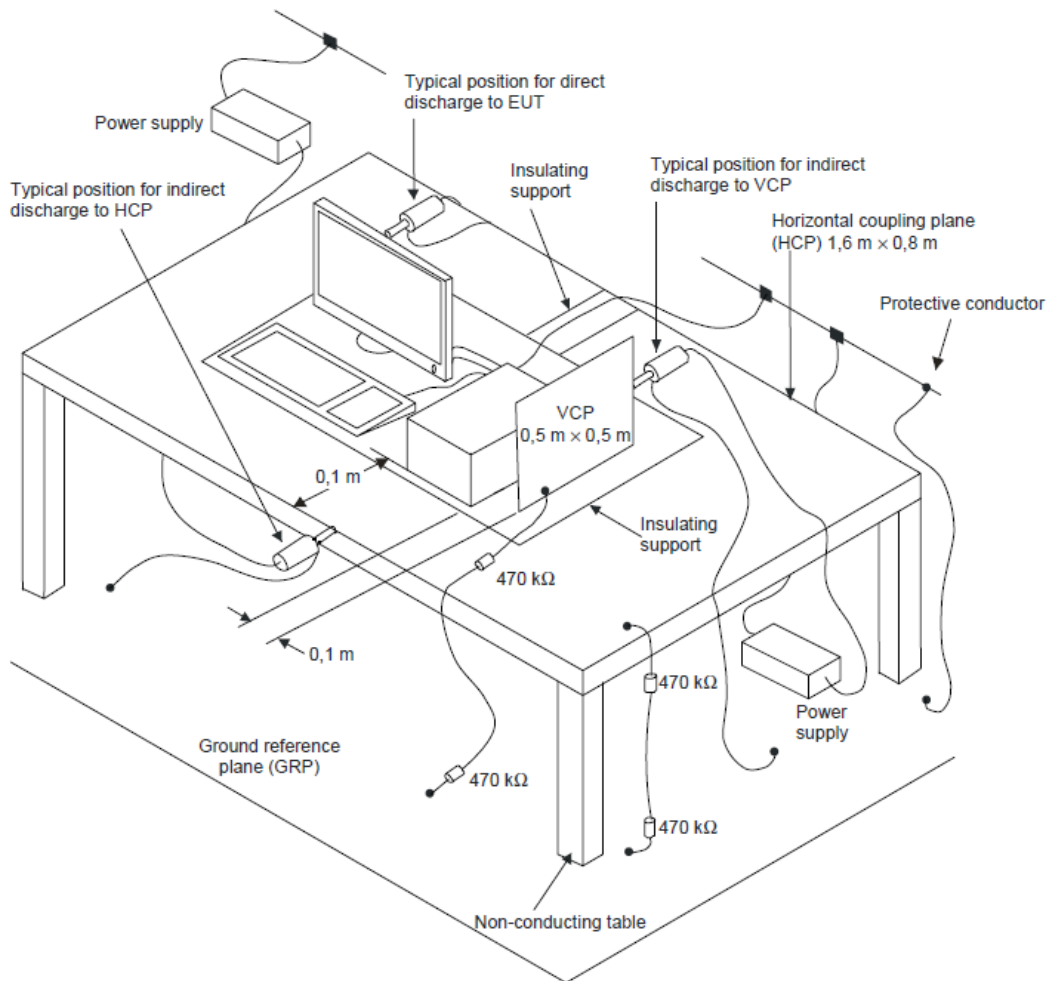



5.3.6 Test Result

| | | | |
|---------------------------------|-----------------------------|------------------|------------|
| Test Voltage | 230Vac, 50Hz or 48Vdc (POE) | Test Date | 2015/12/24 |
| Environmental Conditions | 23°C, 59% RH | Pressure | 1018 mbar |
| Tested by | Guanwei Liao | Test Mode | A, B, C |

Test Results of Direct Application

| Air Discharge | | | | |
|---------------|----------------------|----|----|--------|
| Test Point | Discharge Level (kV) | | | Result |
| | ±2 | ±4 | ±8 | |
| Front | A | A | A | A |
| Back | A | A | A | A |
| Left | A | A | A | A |

* Test location(s) in which discharge to be applied illustrated by photos shown in next page(s).

| Contact Discharge | | | |
|-------------------|----------------------|--------|--------|
| Test Point | Discharge Level (kV) | | Result |
| | ±2 | ±4 | |
| Back | A | B (#1) | B |
| Left | A | A | A |
| Right | A | A | A |
| Top | A | A | A |
| Bottom | A | A | A |

* Test location(s) in which discharge to be applied illustrated by photos shown in next page(s).

Test Results of Indirect Application

| HCP Discharge | | | |
|---------------|----------------------|----|--------|
| Test Point | Discharge Level (kV) | | Result |
| | ±2 | ±4 | |
| Front | A | A | A |
| Back | A | A | A |
| Left | A | A | A |
| Right | A | A | A |

| VCP Discharge | | | |
|---------------|----------------------|----|--------|
| Test Point | Discharge Level (kV) | | Result |
| | ±2 | ±4 | |
| Front | A | A | A |
| Back | A | A | A |
| Left | A | A | A |
| Right | A | A | A |

Note:

Criteria A: The EUT function was correct during the test.

Criteria B: (#1) The transmission interrupted during the test, but could self-recover to the initial operation after the test.

Description of Test Points

Front



Back



*Red Dot - Contact Discharged
Blue Dot - Air Discharged

Left



Right



*Red Dot - Contact Discharged
Blue Dot - Air Discharged

Top



Bottom



*Red Dot - Contact Discharged
Blue Dot - Air Discharged

5.3.7 Photographs of Test Configuration

Test Mode A

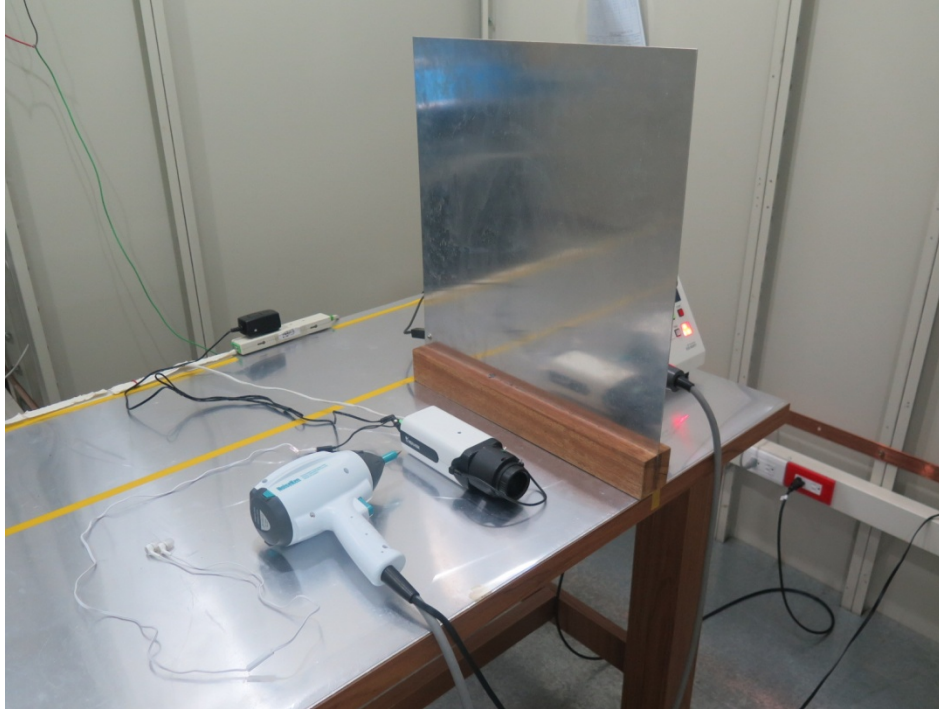

Test Mode B

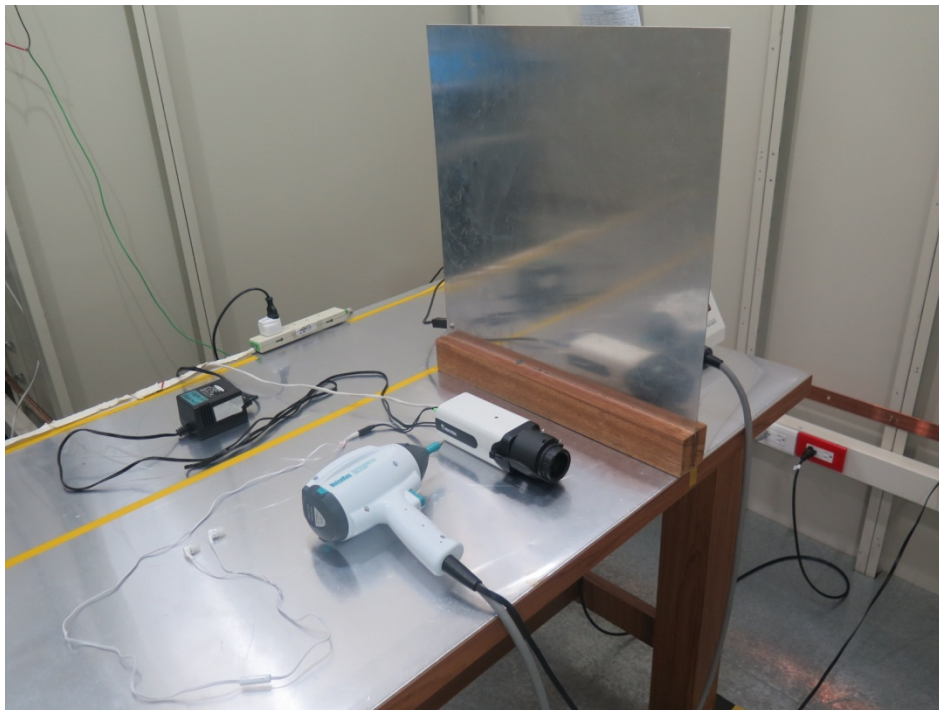

Test Mode C

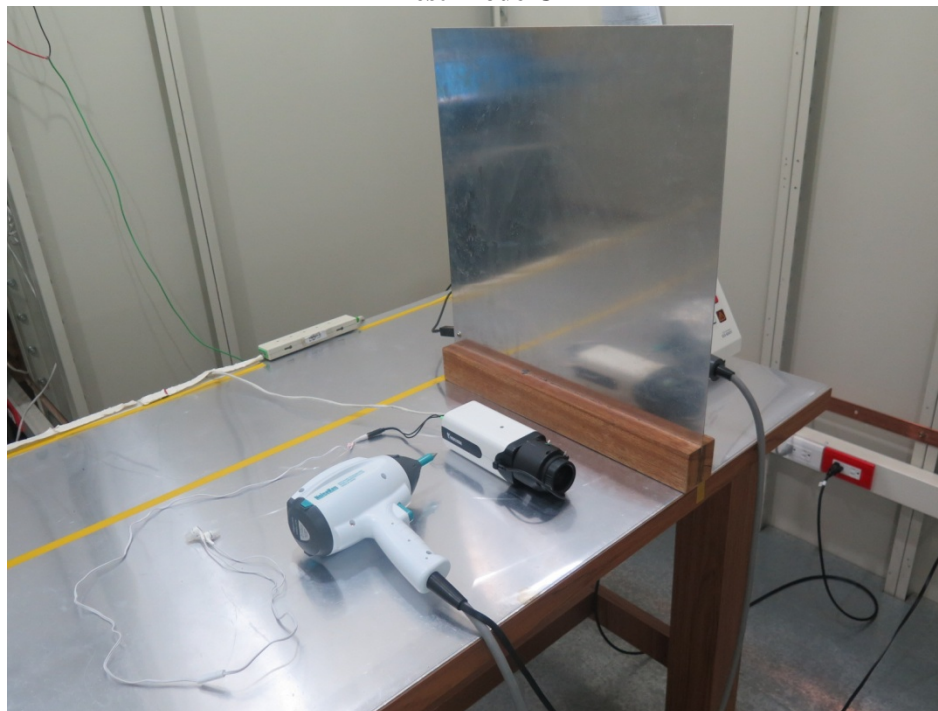

5.4 Radiated, Radio-frequency, Electromagnetic Field Immunity Test (RS)

5.4.1 Test Specification

| | |
|----------------------------|-------------------------------------|
| Standard | IEC/EN 61000-4-3 |
| Frequency Range | 80 MHz - 1000 MHz |
| Field Strength | 3 V/m |
| Modulation | 80%, AM Modulation, 1 kHz Sine Wave |
| Frequency Step | 1% |
| Polarity of Antenna | Horizontal and Vertical |
| Test Distance | 3 m |
| Antenna Height | 1.5 m |
| Dwell Time | 3.0 seconds |

5.4.2 Test Instrument

| Item | Equipment | Manufacturer | Model | Meter No. | Calibration Date |
|------|--|----------------------------------|-------------|------------|---------------------------|
| 1 | RadiCentre ® Modular EMC Test Systems | DARE | CTR1004B | CT-1-080 | No calibration request |
| 2 | RF Signal Generator | DARE | RPR2006C | CT-1-081-1 | No calibration request |
| 3 | LINEAR POWER RF AMPLIFIER | OPHIR | 5225 | CT-1-082 | No calibration request |
| 4 | LINEAR POWER RF AMPLIFIER | OPHIR | 5193 | CT-1-083 | No calibration request |
| 5 | LINEAR POWER RF AMPLIFIER | OPHIR | 5022A | CT-1-084 | No calibration request |
| 6 | Periodic Test-Antenna | Schwarzbeck Mess - Elektronik | STLP 9128 E | CT-1-085 | No calibration request |
| 7 | Microwave Log.-Per. Antenna | Schwarzbeck Mess - Elektronik | ALX-4000E | CT-1-064 | No calibration request |
| 8 | Electric Field Probe | FRANKONIA | EFS-10 | CT-1-060a1 | Aug. 29, 2014 |
| 9 | Measurement Software | EMC-RS | Ver: 2.02 | N/A | No calibration request |

Note: 1. The calibration interval of the above test instruments is 12 months.

5.4.3 Test Procedure

The test procedure was in accordance with IEC 61000-4-3.

The EUT and load, which are placed on a table that is 0.8 meter above ground, are placed with one coincident with the calibration plane such that the distance from antenna to the EUT was 2 meters.

Both horizontal and vertical polarization of the antenna and four sides of the EUT are set on measurement.

In order to judge the EUT performance, a CCD camera is used to monitor EUT screen.

All the scanning conditions are as follows:

| | Condition of Test | Remarks |
|---|--------------------------------|----------------------------|
| 1 | Field Strength | 3V/m |
| 2 | Radiated Signal | AM 80% Modulated with 1kHz |
| 3 | Scanning Frequency | 80 M- 1000MHz |
| 4 | Dwell Time | 3.0 Seconds |
| 5 | Frequency Step Size Δf | 1% |

5.4.4 Deviation from Test Standard

No deviation

5.4.5 Test Setup

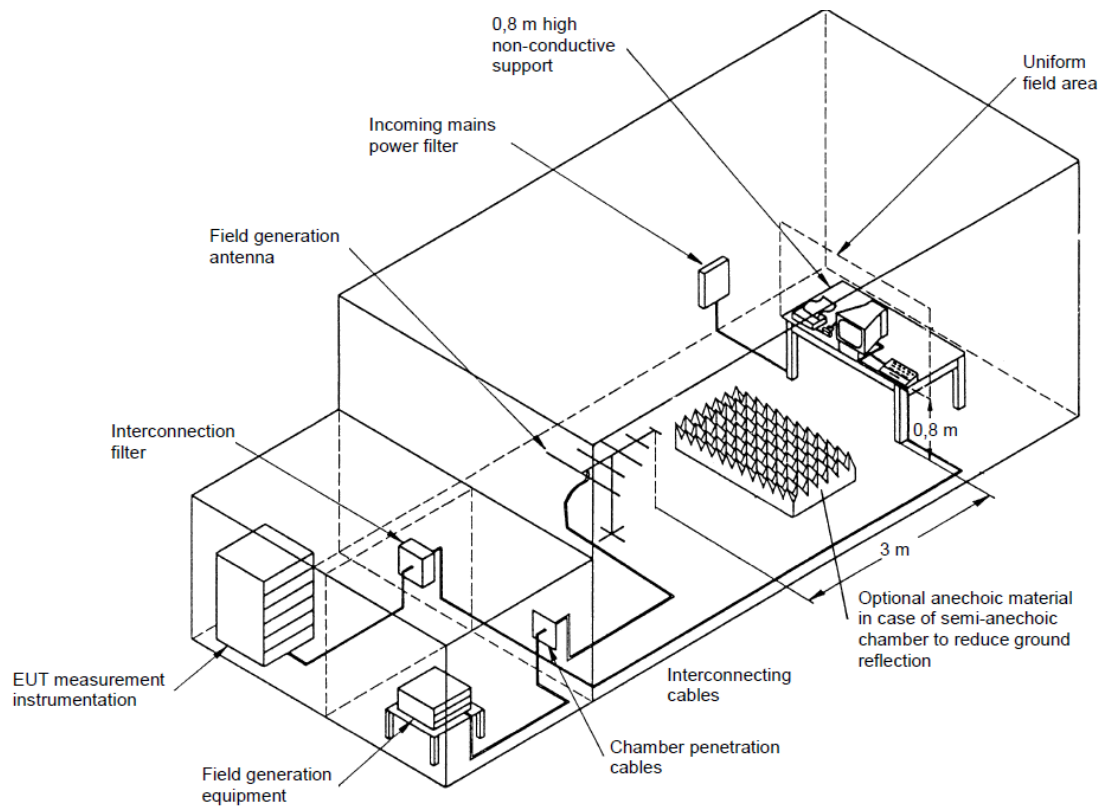

NOTE:

TABLETOP EQUIPMENT

The EUT installed in a representative system as described in section 7 of IEC 61000-4-3 was placed on a non-conductive table 0.8 meters in height.

FLOOR STANDING EQUIPMENT

The EUT installed in a representative system as described in section 7 of IEC 61000-4-3 was placed on a non-conductive wood support 0.1 meters in height.



5.4.6 Test Result

| | | | |
|---------------------|-----------------------------|---------------------------------|--------------|
| Test Voltage | 230Vac, 50Hz or 48Vdc (POE) | Environmental Conditions | 22°C, 59% RH |
| Tested by | Guanwei Liao | Test Date | 2015/12/23 |
| Test Mode | A, B, C | | |

| Frequency Range (MHz) | Azimuth | Polarity | Field Strength (V/m) | Modulation | Result |
|-----------------------|---------|----------|----------------------|---------------|--------|
| 80-1000 | 0 | H/V | 3 | 80% AM (1kHz) | A |
| 80-1000 | 90 | H/V | 3 | 80% AM (1kHz) | A |
| 80-1000 | 180 | H/V | 3 | 80% AM (1kHz) | A |
| 80-1000 | 270 | H/V | 3 | 80% AM (1kHz) | A |
| 80-1000 | Top | H/V | 3 | 80% AM (1kHz) | A |
| 80-1000 | Bottom | H/V | 3 | 80% AM (1kHz) | A |

Note:

Criteria A: The EUT function was correct during the test.

5.4.7 Photographs of Test Configuration

Test Mode A
Front



Back

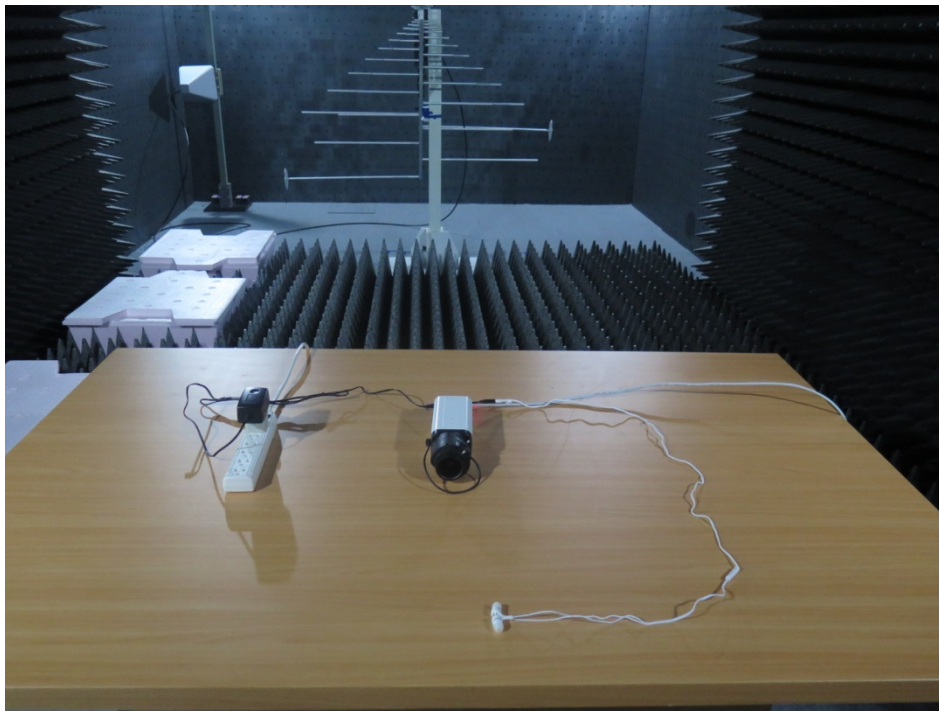

Right



Left



Top

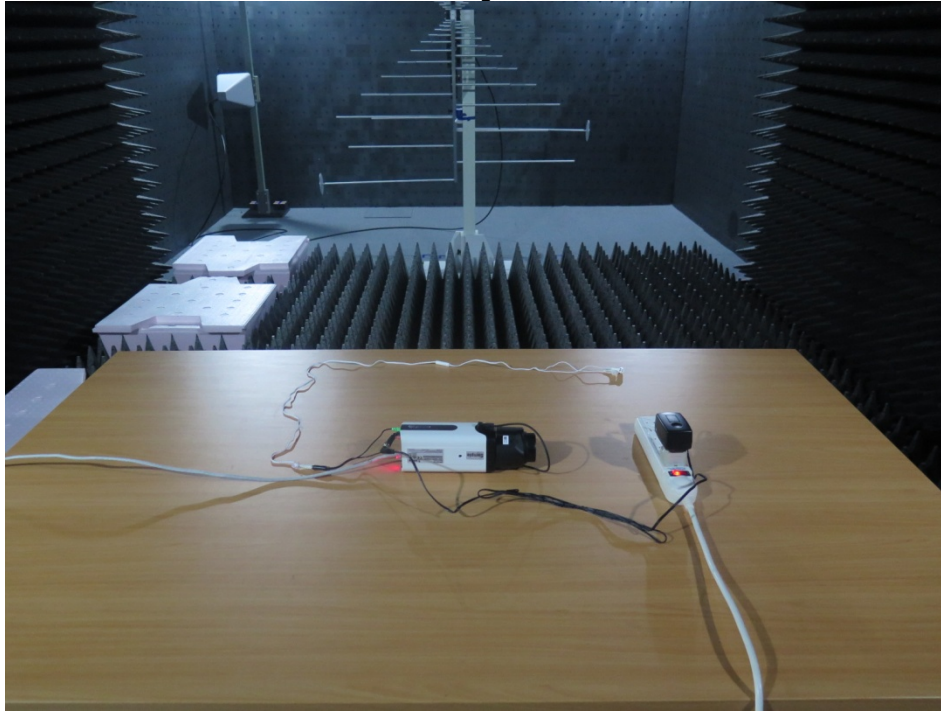

Bottom

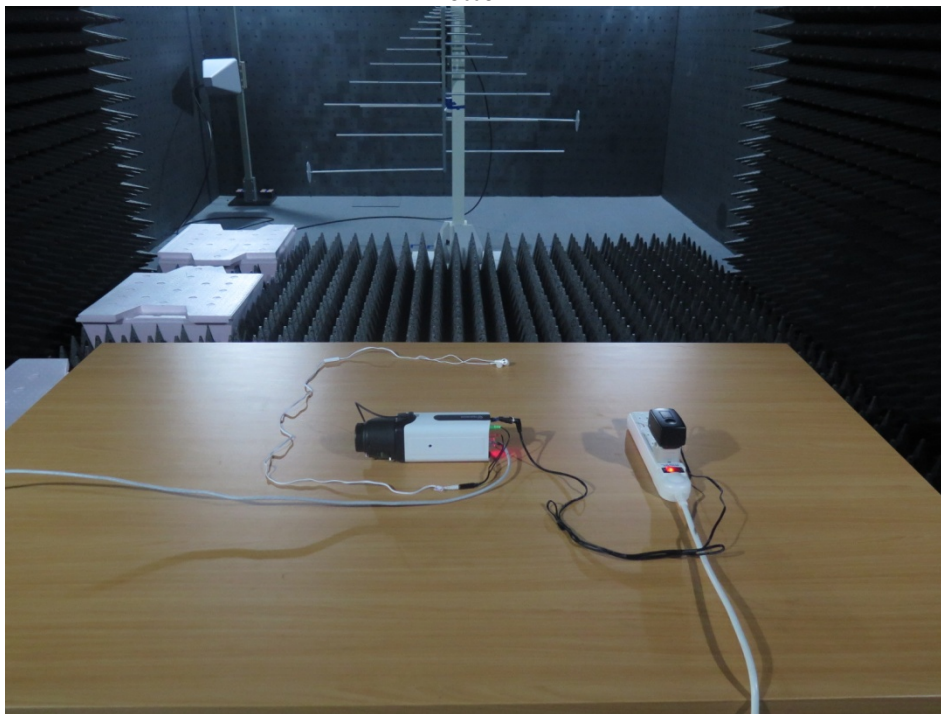

**Test Mode B
Front**

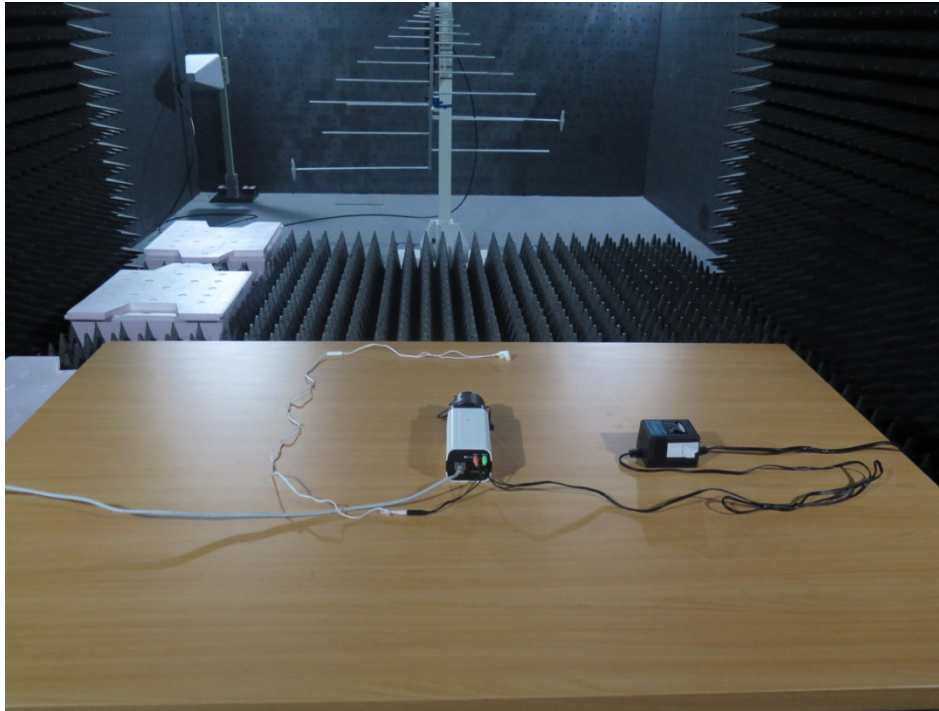

Back



Right



Left



Top

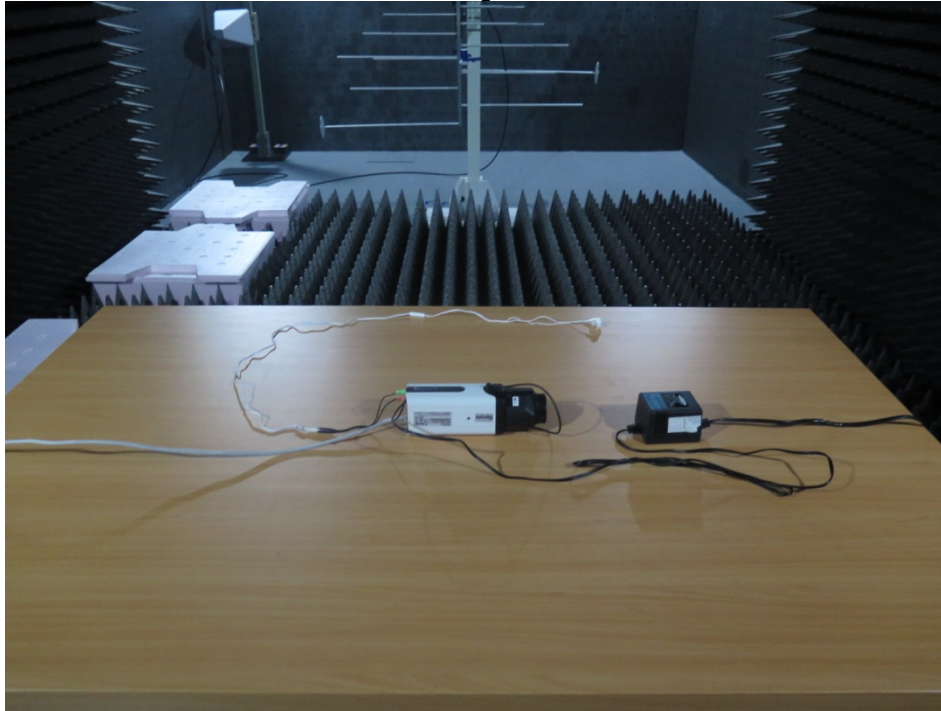

Bottom

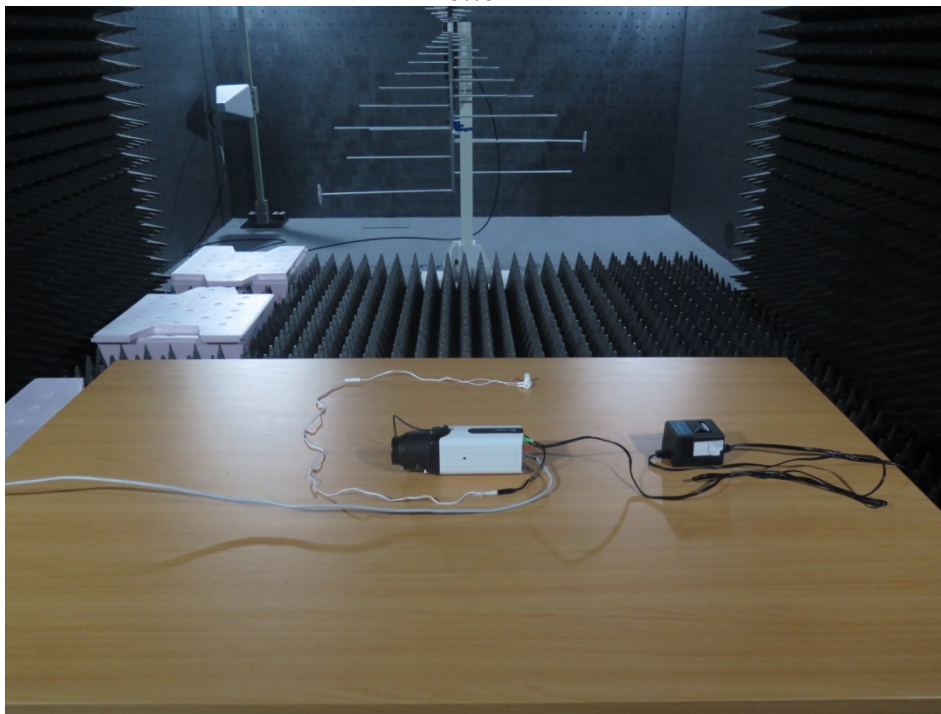

Test Mode C
Front

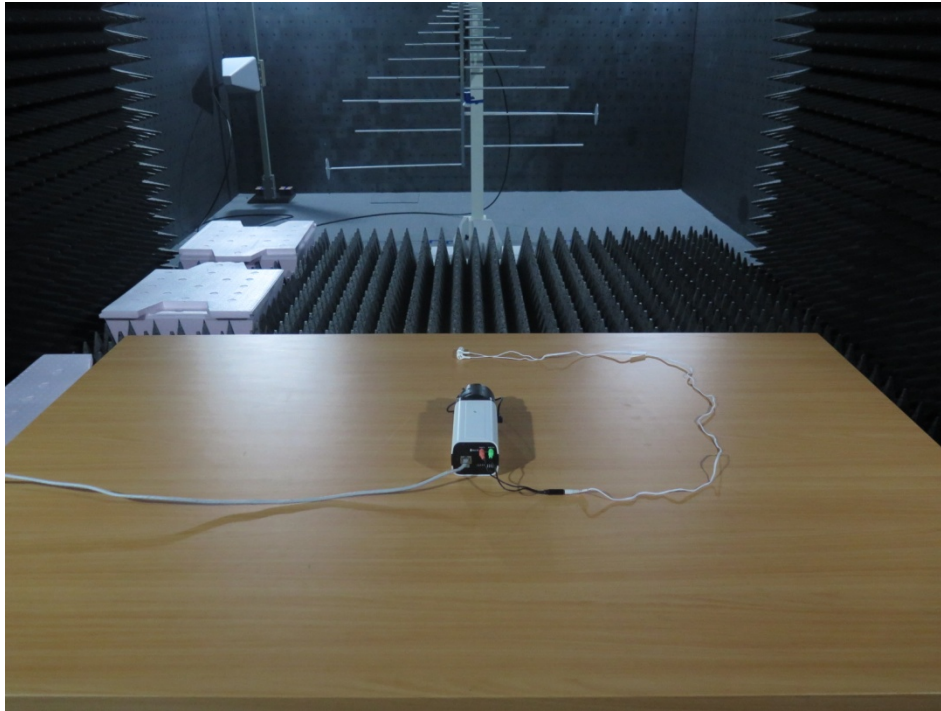

Back



Right



Left



Top

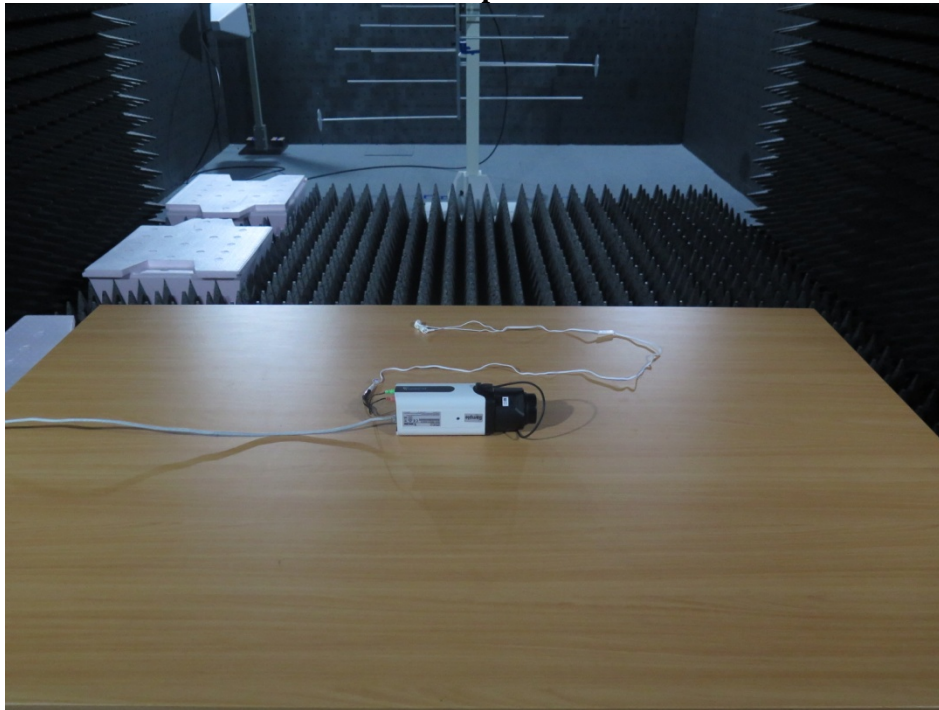

Bottom

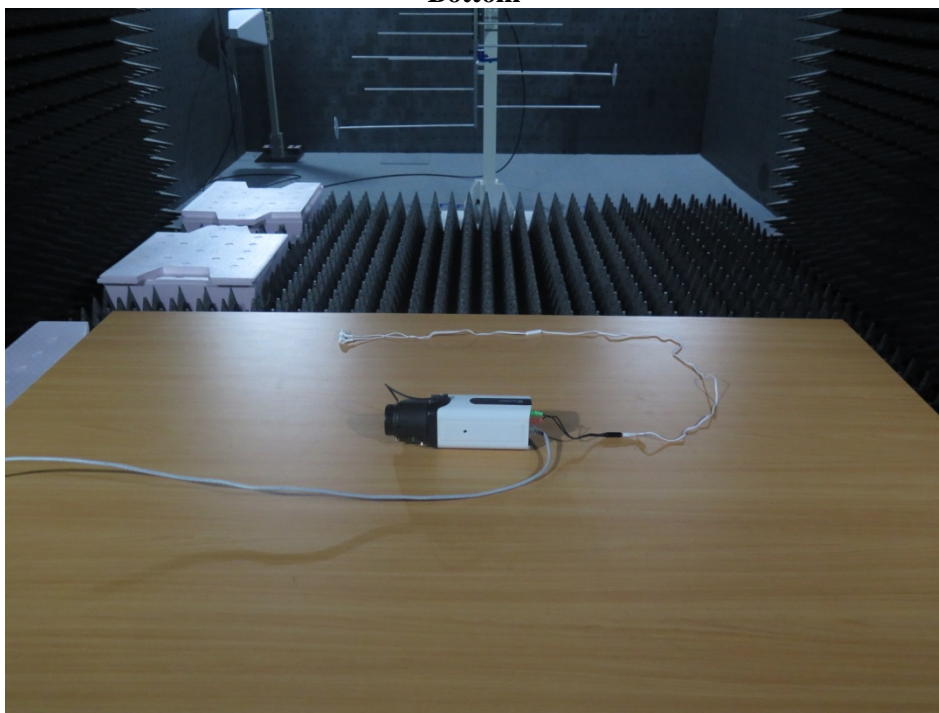

5.5 Electrical Fast Transient /Burst Immunity Test (EFT)

5.5.1 Test Specification

| | |
|--------------------------|---|
| Standard | IEC/EN 61000-4-4 |
| Test Voltage | AC supply lines: ± 1 kV DC Power Port: N/A Signal ports and telecommunication ports: ± 0.5 kV |
| Polarity | Positive & Negative |
| Impulse Frequency | xDSL telecommunication port: 100 kHz other: 5kHz |
| Impulse Wave | 5/50 ns |
| Burst Duration | 15 ms |
| Burst Period | 300 ms |
| Test Duration | Not less than 1 min. |

5.5.2 Test Instrument

| Item | Equipment | Manufacturer | Model | Meter No. | Calibration Date |
|------|----------------------|--------------|----------|-----------|------------------------|
| 1 | EMS Generator | Thermo | EMC Pro | CT-1-030 | Apr. 10, 2015 |
| 2 | Clamp | KeyTek | CCL | CT-1-032 | Apr. 10, 2015 |
| 3 | Measurement Software | CEWare32 | Ver: 4.1 | N/A | No calibration request |

Note: 1. The calibration interval of the above test instruments is 12 months.

5.5.3 Test Procedure

The EUT is placed on a table that is 0.8 meter height. A ground reference plane is placed on the table, and uses a 0.1m insulation between the EUT and ground reference plane.

The minimum area of the ground reference plane is 1m*1m, and 0.65mm thick min, and projected beyond the EUT by at least 0.1m on all sides.

For input AC power ports:

The EUT is connected to the power mains through a coupling device that directly couples the EFT/B interference signal.

Each of the line conductors is impressed with burst noise for 1 minute.

The length of the power lines between the coupling device and the EUT is 0.5m.

5.5.4 Deviation from Test Standard

No deviation

5.5.5 Test Setup

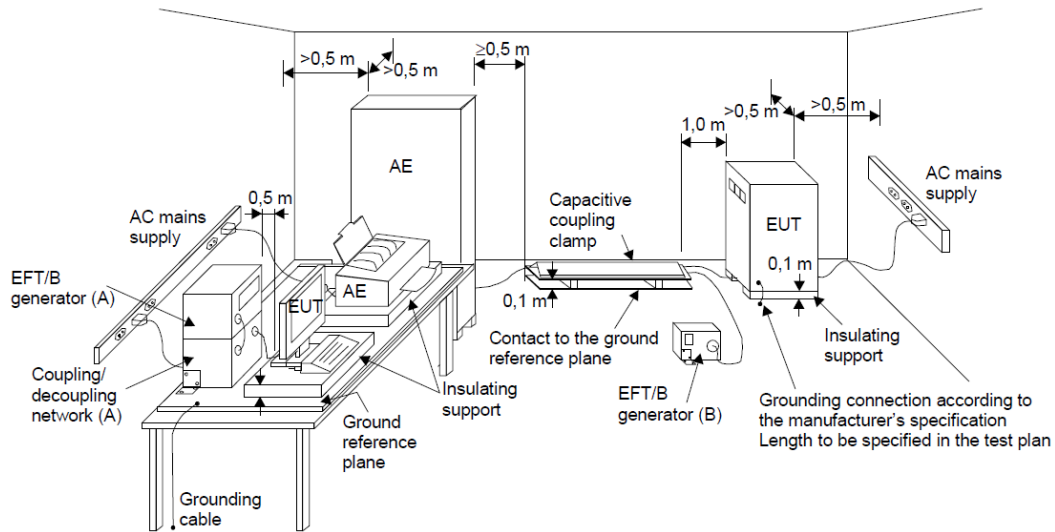

- (A) location for supply line coupling
- (B) location for signal lines coupling

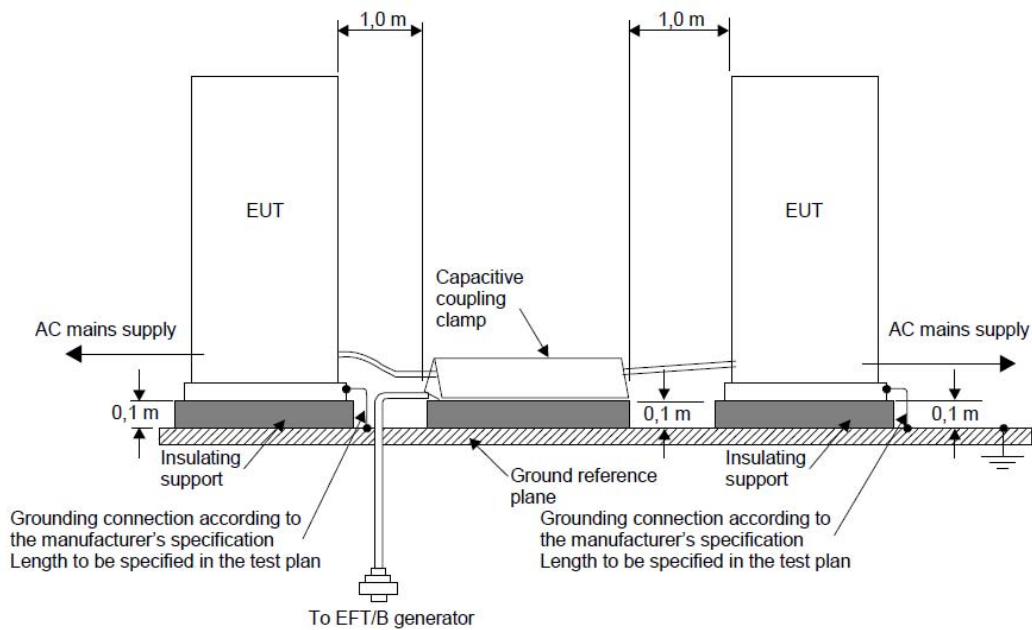



5.5.6 Test Result

| | | | |
|---------------------|--------------|---------------------------------|--------------|
| Test Voltage | 230Vac, 50Hz | Environmental Conditions | 23°C, 60% RH |
| Tested by | Guanwei Liao | Test Date | 2015/12/24 |
| Test Mode | A, B | | |

| Test Point | | Test Level (kV) | Polarity (+/-) | Result |
|---|-------|-----------------|----------------|--------|
| AC Power Port | L | 1 | +/- | A |
| | N | 1 | +/- | A |
| | L + N | 1 | +/- | A |
| Signal Ports Telecommunication Ports | RJ45 | 0.5 | +/- | A |

Note:

Criteria A: The EUT function was correct during the test.

| | | | |
|---------------------|--------------|---------------------------------|--------------|
| Test Voltage | 48Vdc (POE) | Environmental Conditions | 23°C, 60% RH |
| Tested by | Guanwei Liao | Test Date | 2015/12/24 |
| Test Mode | C | | |

| Test Point | | Test Level (kV) | Polarity (+/-) | Result |
|---|------|-----------------|----------------|--------|
| Signal Ports Telecommunication Ports | RJ45 | 0.5 | +/- | A |

Note:

Criteria A: The EUT function was correct during the test.

5.5.7 Photographs of Test Configuration

Test Mode A (Power)



Test Mode A (Clamp)



Test Mode B (Power)



Test Mode B (Clamp)



Test Mode C (Clamp)



5.6 Surge Immunity Test

5.6.1 Test Specification

| | |
|------------------------------|--|
| Standard | IEC/EN 61000-4-5 |
| Wave- Shape | <p>Signal and telecommunication ports(direct to outdoor cables^(Note 1)): 10/700 μs Open Circuit Voltage 5/320 μs Short Circuit Current</p> <p>Input DC power port(direct to outdoor cables^(Note 1)): 1.2/50 μs Open Circuit Voltage 8/20 μs Short Circuit Current</p> <p>Input AC Power ports: 1.2/50 μs Open Circuit Voltage 8 /20 μs Short Circuit Current</p> |
| Test Voltage | <p>Signal and telecommunication ports^(Note 2) (direct to outdoor cables^(Note 1)): w/o primary protectors: N/A, with primary protectors fitted: N/A</p> <p>Input DC power port(direct to outdoor cables^(Note 1)): N/A, Input AC Power ports: Line to line: \pm1kV, Line to earth or ground: N/A</p> |
| Surge Input / Output | L1-L2 |
| Polarity | Positive/Negative |
| Phase Angle | 0°/90°/180°/270° |
| Pulse Repetition Rate | 1 time / min. (maximum) |
| Times | 5 positive and 5 negative at selected points |

- Note:** 1. This test is only applicable only to ports, which according to the manufacturer's specification, may connect directly to outdoor cables
2. For ports where primary protection is intended, surges are applied at voltages up to 4 kV with the primary protectors fitted. Otherwise the 1 kV test level is applied without primary protection in place.

5.6.2 Test Instrument

| Item | Equipment | Manufacturer | Model | Meter No. | Calibration Date |
|------|----------------------|--------------|-------------|-------------|------------------------|
| 1 | EMS Generator | Thermo | EMC Pro | CT-1-030 | Apr. 10, 2015 |
| 2 | Surge CDN | 3cTest | CDN-405T8A1 | CT-1-074(5) | Mar. 03, 2015 |
| 3 | Measurement Software | CEWare32 | Ver: 4.1 | N/A | No calibration request |

- Note:** 1. The calibration interval of the above test instruments is 12 months.

5.6.3 Test Procedure

The EUT is placed on a table that is 0.8 meter above a metal ground plane measured 1m*1m minimum and 0.65mm thick minimum and projected beyond the EUT by at least 0.1m on all sides. The length of power cord between the coupling device and the EUT shall be 2m or less.

For input AC power ports:

The EUT is connected to the power mains through a coupling device that directly couples the surge interference signal.

The surge noise shall be applied synchronized to the voltage phase at 0° , 90° , 180° , 270° and the peak value of the AC voltage wave. (Positive and negative)

Each of Line to Earth and Line to Line is impressed with a sequence of five surge voltages with interval of 1 minute.

5.6.4 Deviation from Test Standard

No deviation

5.6.5 Test Setup

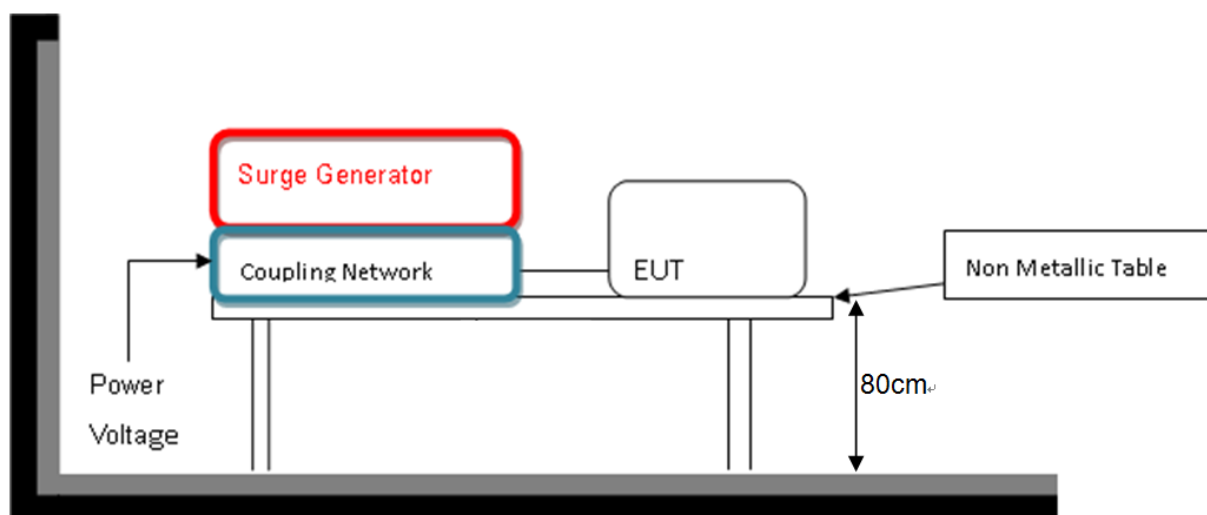



5.6.6 Test Result

| | | | |
|---------------------|--------------|---------------------------------|--------------|
| Test Voltage | 230Vac, 50Hz | Environmental Conditions | 23°C, 60% RH |
| Tested by | Guanwei Liao | Test Date | 2015/12/24 |
| Test Mode | A, B | | |

| AC Power Port | | | | | |
|---------------|-------|----------------|-------------------|---|--------|
| Test Point | Phase | Polarity (+/-) | Test Voltage (kV) | | Result |
| | | | 0.5 | 1 | |
| L to N | 0° | +/- | A | A | A |
| | 90° | +/- | A | A | |
| | 180° | +/- | A | A | |
| | 270° | +/- | A | A | |

Note:

Criteria A: The EUT function was correct during the test.

5.6.7 Photographs of Test Configuration

Test Mode A



Test Mode B



5.7 Continuous Conducted Disturbances (CS)

5.7.1 Test Specification

| | |
|------------------------|-------------------------------------|
| Standard | IEC/EN 61000-4-6 |
| Frequency Range | 0.15 MHz - 80 MHz |
| Voltage Level | 3 V(rms) |
| Modulation | AM Modulation, 80%, 1 kHz Sine Wave |
| Frequency Step | 1% of fundamental |
| Dwell Time | 3 seconds |

5.7.2 Test Instrument

| Item | Equipment | Manufacturer | Model | Meter No. | Calibration Date |
|------|--|--------------|-------------|-----------|------------------------|
| 1 | Coupling clamp according to IEC 6100-4-6 | FRANKONIA | EMCL-2 | CT-1-049 | Mar. 30, 2015 |
| 2 | CDN for screened cables | FRANKONIA | CDN S1/75Ω | CT-1-050 | Mar. 30, 2015 |
| 3 | CDN for power supply lines | FRANKONIA | CDN M2+M3 | CT-1-054 | Mar. 30, 2015 |
| 4 | 6 dB Attenuator | BIRD | 75-A-FFN-06 | CT-1-056 | Mar. 31, 2015 |
| 5 | Compact Immunity Test System acc | FRANKONIA | CIT-10/75 | CT-1-057 | Mar. 27, 2015 |
| 6 | Measurement Software | HUBERT | Ver: 1.1.2 | N/A | No calibration request |

Note: 1. The calibration interval of the above test instruments is 12 months.

5.7.3 Test Procedure

The EUT is placed on 0.1m insulation table between the EUT and ground reference plane.

For input AC power ports:

The EUT is connected to the power mains through a coupling and decoupling networks for power supply lines. And directly couples the disturbances signal into EUT.

Auxiliary equipment (AE) required for the defined operation of the EUT according to the specifications of the product committee.

5.7.4 Deviation from Test Standard

No deviation

5.7.5 Test Setup

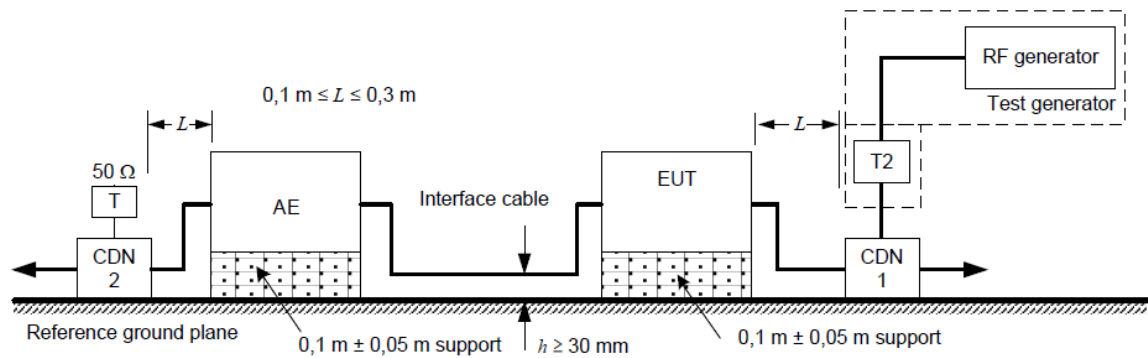

The interface cable is set at 1 m if possible.

a) Schematic setup for a 2-port EUT connected to only 1 CDN

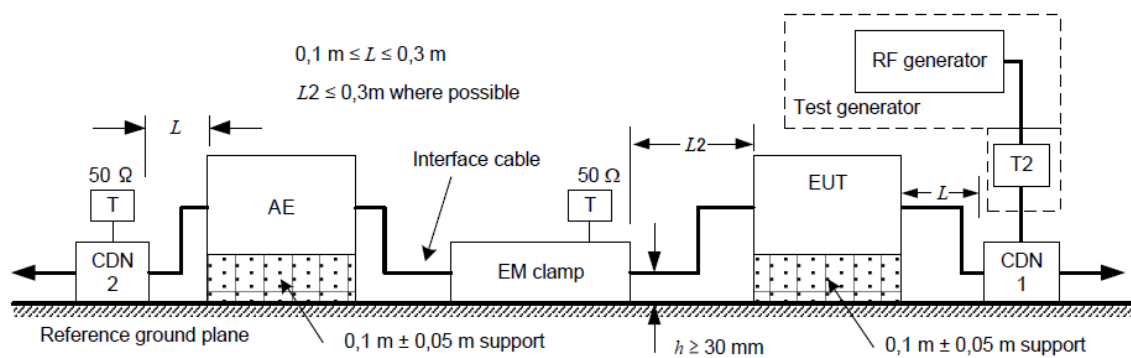

Note:

T: Termination 50 Ω

T2: Power attenuator (6 dB)

CDN: Coupling and decoupling network

Injection clamp: current clamp or EM clamp



5.7.6 Test Result

| | | | |
|---------------------|--------------|---------------------------------|----------------|
| Test Voltage | 230Vac, 50Hz | Environmental Conditions | 21.5°C, 44% RH |
| Tested by | Toby Chung | Test Date | 2015/12/18 |
| Test Mode | A, B | | |

| Frequency Range (MHz) | Tested Port | Injection Method | Test Level (V _{r.m.s.}) | Modulation | Result |
|-----------------------|-------------|------------------|-----------------------------------|--------------|--------|
| 0.15 - 80 | AC Power | CDN-M2 +M3 | 3 | 80% AM, 1kHz | A |
| 0.15 - 80 | RJ45 | CLAMP | 3 | 80% AM, 1kHz | A |

Note:

Criteria A: The EUT function was correct during the test.

| | | | |
|---------------------|-------------|---------------------------------|----------------|
| Test Voltage | 48Vdc (POE) | Environmental Conditions | 21.5°C, 44% RH |
| Tested by | Toby Chung | Test Date | 2015/12/18 |
| Test Mode | C | | |

| Frequency Range (MHz) | Tested Port | Injection Method | Test Level (V _{r.m.s.}) | Modulation | Result |
|-----------------------|-------------|------------------|-----------------------------------|--------------|--------|
| 0.15 - 80 | RJ45 | CLAMP | 3 | 80% AM, 1kHz | A |

Note:

Criteria A: The EUT function was correct during the test.

5.7.7 Photographs of Test Configuration

**Test Mode A
(Power)**

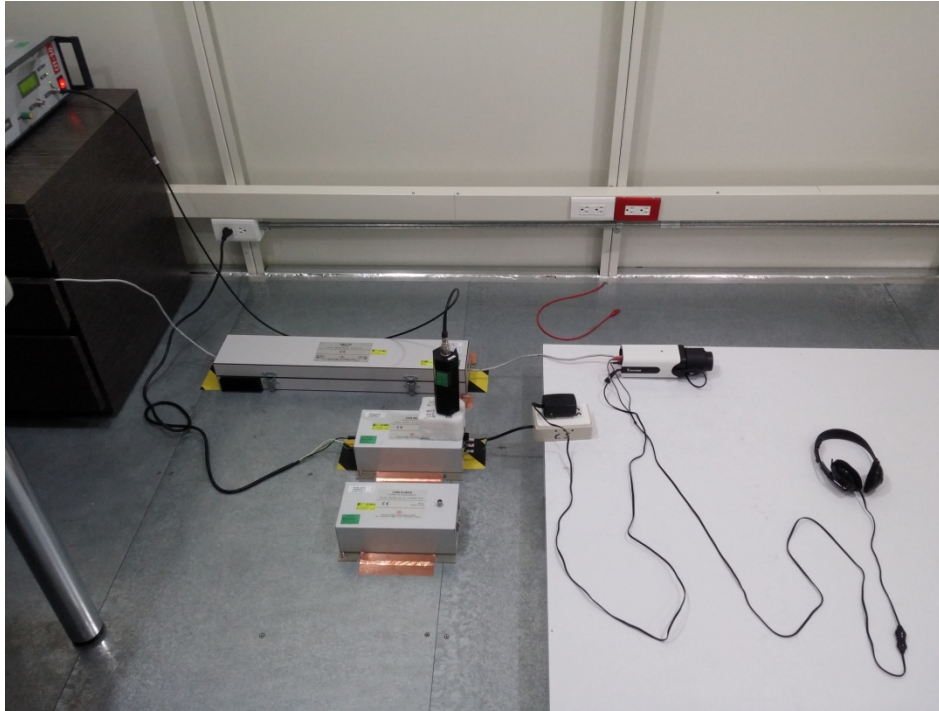

(Signal)

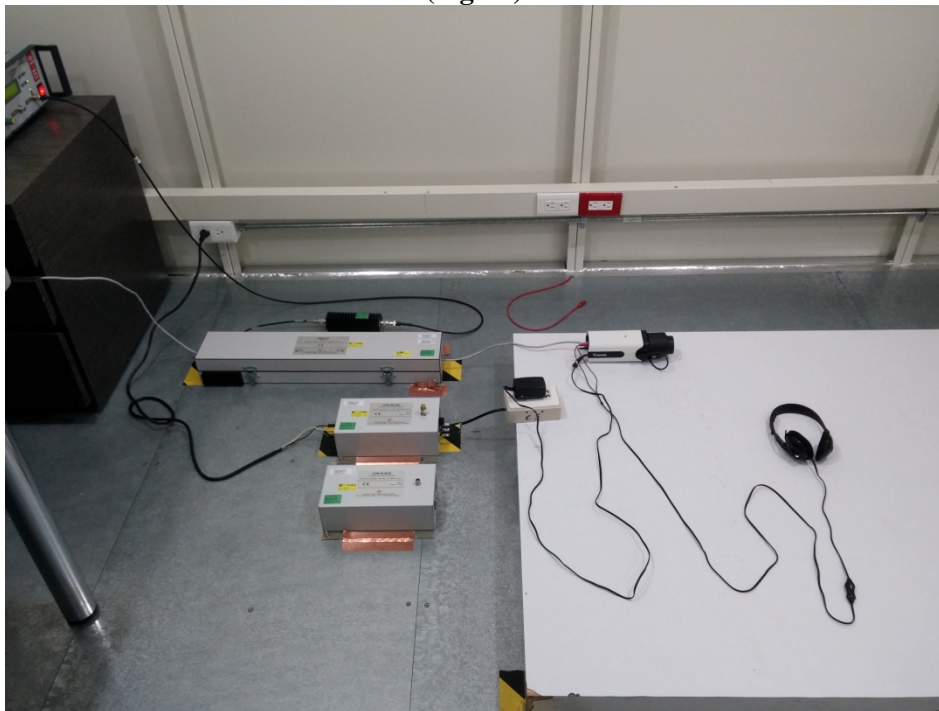

**Test Mode B
(Power)**

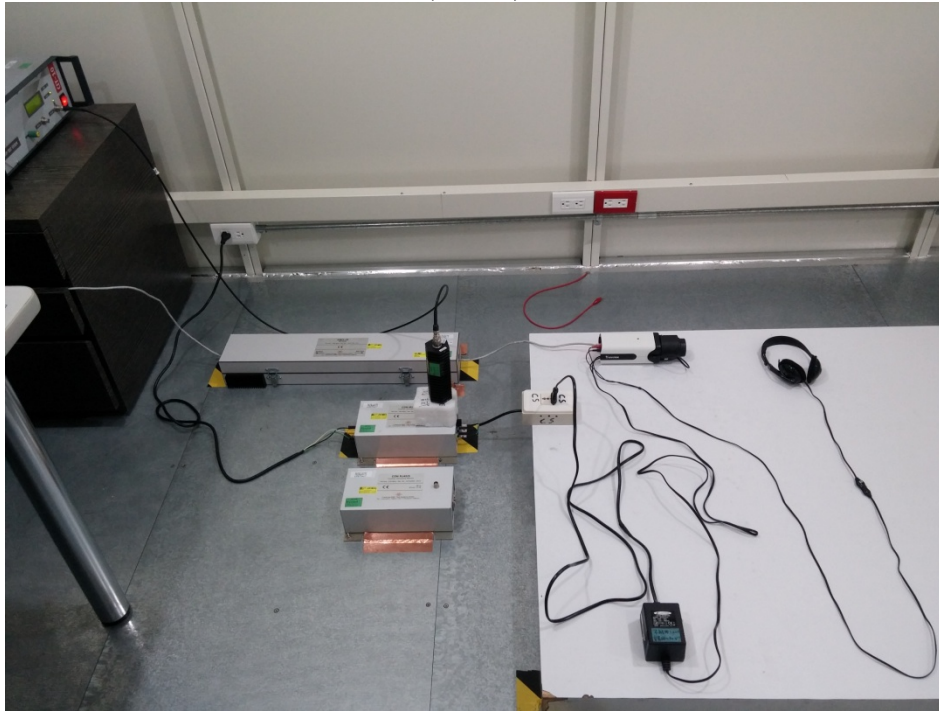

(Signal)

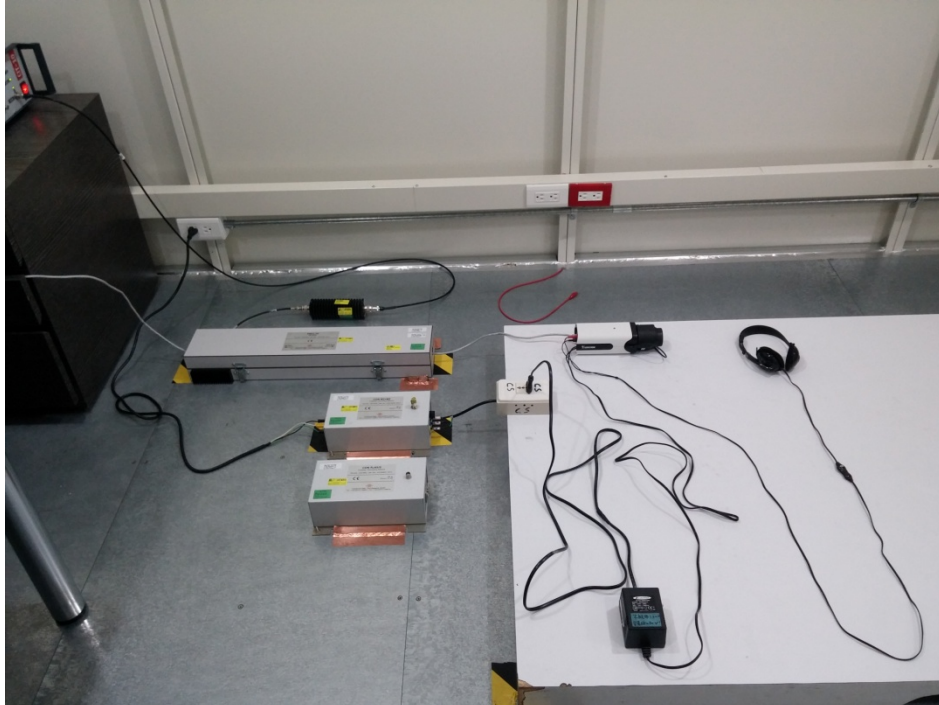

**Test Mode C
(Signal)**

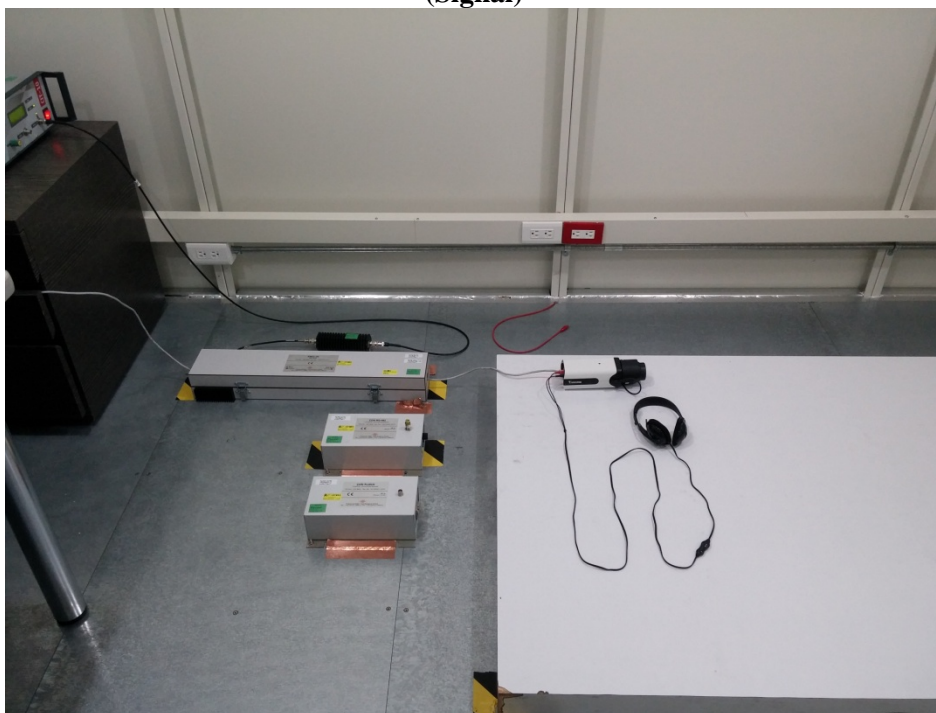

5.8 Power Frequency Magnetic Field Immunity Test

5.8.1 Test Specification

| | |
|-------------------------|-------------------------|
| Standard | IEC/EN 61000-4-8 |
| Frequency Range | 50/60Hz |
| Field Strength | 1 A/m |
| Observation Time | 1 minute |
| Inductance Coil | Rectangular type, 1mx1m |

5.8.2 Test Instrument

| Item | Equipment | Manufacturer | Model | Meter No. | Calibration Date |
|-------------|------------------|---------------------|--------------|------------------|-------------------------|
| 1 | PFMF | HAEFELY | MFS-100 | CT-1-066 | Aug. 03, 2015 |

Note: 1. The calibration interval of the above test instruments is 12 months.

5.8.3 Test Procedure

The EUT is placed on a table which is 0.8 meter above a metal ground plane measured at least 1m*1m minimum. The test magnetic field shall be placed at central of the induction coil.

The test magnetic Field shall be applied 10 minutes by the immersion method to the EUT, and the induction coil shall be rotated by 90° in order to expose the EUT to the test field with different orientation (X, Y, Z Orientations).

5.8.4 Deviation from Test Standard

No deviation

5.8.5 Test Setup

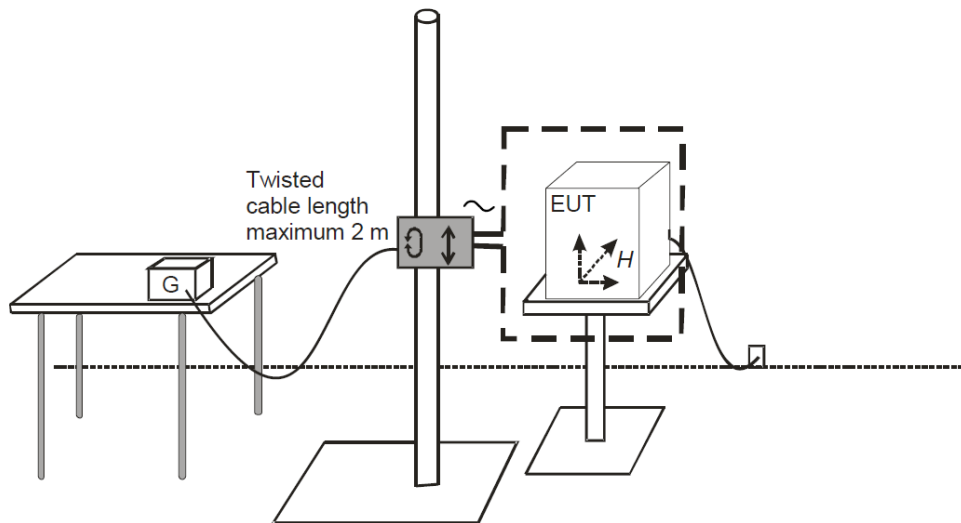

For the actual test configuration, please refer to 5.8.7.

NOTE:

TABLETOP EQUIPMENT

The equipment shall be subjected to the test magnetic field by using the induction coil of standard dimension (1 m x 1 m). The induction coil shall then be rotated by 90 degrees in order to expose the EUT to the test field with different orientations.

FLOOR-STANDING EQUIPMENT

The equipment shall be subjected to the test magnetic field by using induction coils of suitable dimensions. The test shall be repeated by moving and shifting the induction coils, in order to test the whole volume of the EUT for each orthogonal direction. The test shall be repeated with the coil shifted to different positions along the side of the EUT, in steps corresponding to 50 % of the shortest side of the coil. The induction coil shall then be rotated by 90 degrees in order to expose the EUT to the test field with different orientations.



5.8.6 Test Result

| | | | |
|---------------------|-----------------------------|---------------------------------|--------------|
| Test Voltage | 230Vac, 50Hz or 48Vdc (POE) | Environmental Conditions | 22°C, 59% RH |
| Tested by | Guanwei Liao | Test Date | 2015/12/23 |
| Test Mode | A, B, C | | |

| Test Coil Position | Frequency (Hz) | Magnetic Strength (A/m) | Result |
|---------------------------|-----------------------|--------------------------------|---------------|
| X - Axis | 50/60 | 1 | A |
| Y - Axis | 50/60 | 1 | A |
| Z - Axis | 50/60 | 1 | A |

Note:

Criteria A: The EUT function was correct during the test.

5.8.7 Photographs of Test Configuration

Test Mode A



Test Mode B



Test Mode C



5.9 Voltage Dips & Short Interruptions

5.9.1 Test Specification

| | |
|-------------------------------|--|
| Basic Standard | IEC/EN 61000-4-11 |
| Test Level | Voltage Dips: >95% reduction - 0.5 period 30% reduction - 25 period Voltage Interruptions: >95% reduction - 250 period |
| Test Duration Time | Minimum 3 test events in sequence |
| Interval between Event | Minimum 10 seconds |
| Phase Angle | 0° / 180° |
| Test Cycle | 3 times |

5.9.2 Test Instrument

| Item | Equipment | Manufacturer | Model | Meter No. | Calibration Date |
|------|----------------------|--------------|----------|-----------|------------------------|
| 1 | EMS Generator | Thermo | EMC Pro | CT-1-030 | Apr. 10, 2015 |
| 2 | Measurement Software | CEWare32 | Ver: 4.1 | N/A | No calibration request |

Note: 1. The calibration interval of the above test instruments is 12 months.

5.9.3 Test Procedure

Before starting the test of a given EUT, a test plan shall be prepared.

The test plan should be representative of the way the system is actually used.

Systems may require a precise pre-analysis to define which system configurations must be tested to reproduce field situations.

Test cases must be explained and indicated in the Test report.

It is recommended that the test plan include the following items:

- the type designation of the EUT;
- information on possible connections (plugs, terminals, etc.) and corresponding cables, and peripherals;
- input power port of equipment to be tested;
- representative operational modes of the EUT for the test;
- performance criteria used and defined in the technical specifications;
- operational mode(s) of equipment;
- description of the test set-up.

If the actual operating signal sources are not available to the EUT, they may be simulated.

For each test, any degradation of performance shall be recorded. The monitoring equipment should be capable of displaying the status of the operational mode of the EUT during and after the tests. After each group of tests, a full functional check shall be performed.

5.9.4 Deviation from Test Standard

No deviation

5.9.5 Test Setup

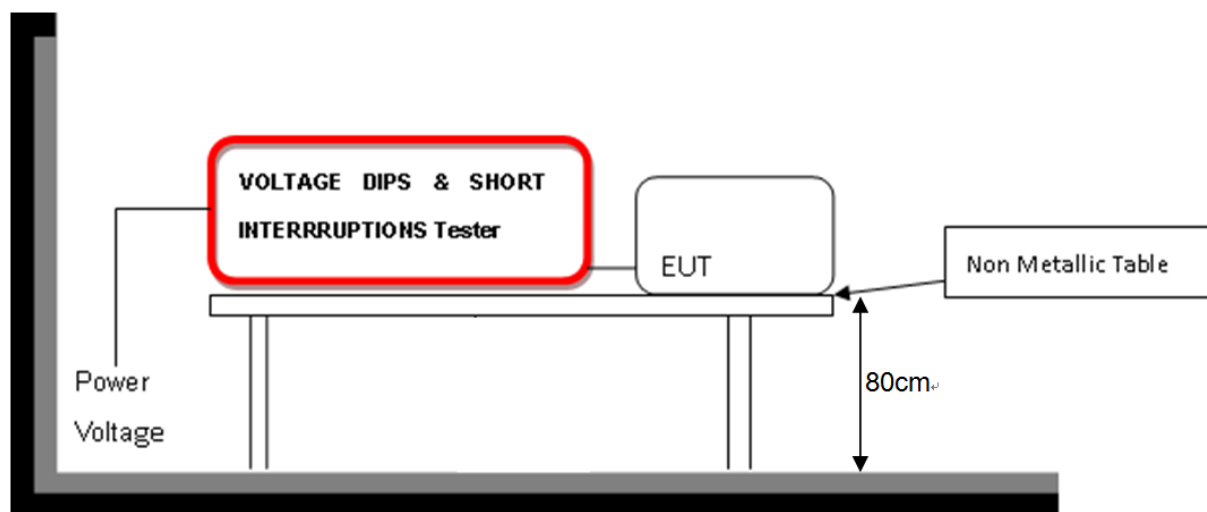

5.9.6 Test Result

| | | | |
|---------------------|------------------|---------------------------------|--------------|
| Test Voltage | 100-240Vac, 50Hz | Environmental Conditions | 23°C, 60% RH |
| Tested by | Guanwei Liao | Test Date | 2015/12/24 |
| Test Mode | A, B | | |

| 230Vac, 50Hz | | | |
|-----------------------|-------------|-------------------|--------|
| Test Item | % Reduction | Duration (Period) | Result |
| Voltage Dips | >95 | 0.5 | A |
| | 30 | 25 | A |
| Voltage interruptions | >95 | 250 | B (#1) |

| 240Vac, 50Hz | | | |
|-----------------------|-------------|-------------------|--------|
| Test Item | % Reduction | Duration (Period) | Result |
| Voltage Dips | >95 | 0.5 | A |
| | 30 | 25 | A |
| Voltage interruptions | >95 | 250 | B (#1) |

| 100Vac, 50Hz | | | |
|-----------------------|-------------|-------------------|--------|
| Test Item | % Reduction | Duration (Period) | Result |
| Voltage Dips | >95 | 0.5 | A |
| | 30 | 25 | A |
| Voltage interruptions | >95 | 250 | B (#1) |

Note:

Criteria A: The EUT function was correct during the test.

Criteria B: (#1) The LAN interrupted during the test, but could self-recover to the initial operation after the test.

5.9.7 Photographs of Test Configuration

Test Mode A



Test Mode B



< End Page >