

# VCCI Appendix Report

Product Name : Network Camera  
Model No. : IB9371-EHT, IB9371-HT

Applicant : VIVOTEK INC.  
Address : 6F, No.192, Lien-Cheng Rd., Chung-Ho , New Taipei City,  
235, Taiwan, R.O.C.

Date of Receipt : 2016/01/29  
Issued Date : 2016/02/23  
Report No. : 1620085R-ITJPP01V00  
Report Version : V1.0



The test results relate only to the samples tested.

The test results shown in the test report are traceable to the national/international standard through the calibration of the equipment and evaluated measurement uncertainty herein.

This report must not be used to claim product endorsement by TAF or any agency of the government.

The test report shall not be reproduced without the written approval of QuieTek Corporation.

# Test Report

Issued Date : 2016/02/23  
 Report No. : 1620085R-ITJPP01V00



Product Name : Network Camera  
 Applicant : VIVOTEK INC.  
 Address : 6F, No.192, Lien-Cheng Rd., Chung-Ho , New Taipei City,  
 235, Taiwan, R.O.C.  
 Manufacturer : VIVOTEK INC.  
 Model No. : IB9371-EHT, IB9371-HT  
 EUT Rated Voltage : Power By PoE, DC12V  
 EUT Test Voltage : Power By PoE, DC12V  
 Trade Name : VIVOTEK  
 Applicable Standard : VCCI: 2015-04 Class A  
 Test Result : Complied  
 Performed Location : Quietek Corporation (Linkou Laboratory)  
 No.5-22, Ruishukeng, Linkou Dist., New Taipei City 24451,  
 Taiwan, R.O.C.  
 TEL:+866-2-8601-3788 / FAX:+886-2-8601-3789

Documented By : Jessie Ciou  
 (Adm. Assistant / Jessie Ciou )  
 Reviewed By : Simon Tsai  
 ( Engineer / Simon Tsai )  
 Approved By : Vincent Lin  
 ( Director / Vincent Lin )

## Laboratory Information

We, **Quietek Corporation**, are an independent EMC and safety consultancy that was established the whole facility in our laboratories. The test facility has been accredited/accepted (audited or listed) by the following related bodies in compliance with ISO 17025, EN 45001 and specified testing scopes:

<b>Taiwan R.O.C.</b>	<b>:</b>	<b>BSMI, NCC, TAF</b>
<b>Norway</b>	<b>:</b>	<b>DNV</b>
<b>USA</b>	<b>:</b>	<b>FCC</b>
<b>Japan</b>	<b>:</b>	<b>VCCI</b>

The related certificate for our laboratories about the test site and management system can be downloaded from Quietek Corporation's Web Site : <http://www.quietek.com/chinese/about/certificates.aspx?bval=5>

The address and introduction of Quietek Corporation's laboratories can be founded in our Web site : <http://www.quietek.com/>

If you have any comments, Please don't hesitate to contact us. Our contact information is as below:

### **HsinChu Testing Laboratory :**

No.75-2, 3rd Lin, Wangye Keng, Yonghxing Tsuen, Qionglin Shiang, Hsinchu County 307, Taiwan, R.O.C.

TEL:+886-3-592-8858 / FAX:+886-3-592-8859 E-Mail : [service@quietek.com](mailto:service@quietek.com)

### **Linkou Testing Laboratory :**

No.5-22, Ruishukeng, Linkou Dist., New Taipei City 24451, Taiwan, R.O.C.

TEL : 886-2-8601-3788 / FAX : 886-2-8601-3789 E-Mail : [service@quietek.com](mailto:service@quietek.com)

### **Suzhou (China) Testing Laboratory :**

No. 99 Hongye Rd., Suzhou Industrial Park Loufeng Hi-Tech Development Zone., Suzhou,China.

TEL : +86-512-6251-5088 / FAX : +86-512-6251-5098 E-Mail : [service@quietek.com](mailto:service@quietek.com)

## TABLE OF CONTENTS

Description	Page
1. General Information .....	5
1.1. EUT Description.....	5
1.2. Mode of Operation .....	6
1.3. Tested System Details .....	7
1.4. Configuration of Tested System .....	8
1.5. EUT Exercise Software .....	10
2. Technical Test .....	11
2.1. Summary of Test Result.....	11
2.2. List of Test Equipment.....	12
2.3. Measurement Uncertainty .....	13
2.4. Test Environment .....	14
3. Conducted Emission .....	15
3.1. Test Specification .....	15
3.2. Test Setup.....	15
3.3. Limit .....	15
3.4. Test Procedure.....	16
3.5. Deviation from Test Standard.....	16
3.6. Test Result .....	17
3.7. Test Photograph.....	23
4. Conducted Emissions (Telecommunication Ports).....	25
4.1. Test Specification .....	25
4.2. Test Setup.....	25
4.3. Limit .....	25
4.4. Test Procedure.....	26
4.5. Deviation from Test Standard.....	26
4.6. Test Result .....	27
4.7. Test Photograph.....	39
5. Radiated Emission .....	42
5.1. Test Specification .....	42
5.2. Test Setup.....	42
5.3. Limit .....	43
5.4. Test Procedure.....	43
5.5. Deviation from Test Standard.....	43
5.6. Test Result .....	44
5.7. Test Photograph.....	52
6. Attachment.....	55
EUT Photograph .....	55

**1. General Information**

**1.1. EUT Description**

Product Name	Network Camera
Trade Name	VIVOTEK
Model No.	IB9371-EHT, IB9371-HT

Component	
Power Adapter	MFR: ENG, M/N: 3A-183WP12 Input: 100-240V, 50-60Hz, 0.6A Output: 12V $\overline{=}$ 1.5A Cable Out: Non-shielded, 1.8m
Maximum clock frequency	1600MHz

Note:

1. This appendix report was based on Quietek report No.: 1590031R-ITJPP01V00
2. The different is adding Ground.
3. The different of each model is shown as below:

Model No.	Description
IB9371-EHT	With Heater
IB9371-HT	Without Heater

**1.2. Mode of Operation**

QuieTek has verified the construction and function in typical operation. All the test modes were carried out with the EUT in normal operation, which was shown in this test report and defined as:

Pre-Test Mode	
Mode 1: IB9371-HT, Poe MODE Mode 2: IB9371-HT, DC MODE	
Final Test Mode	
Emission	Mode 1: IB9371-HT, Poe MODE Mode 2: IB9371-HT, DC MODE
Note : According to pre-test data, we choose the worst case mode 1, 2 as the final and full testing.	

### 1.3. Tested System Details

The types for all equipments, plus descriptions of all cables used in the tested system (including inserted cards) are:

Test Mode		Mode 1			
Product		Manufacturer	Model No.	Serial No.	Power Cord
1	Notebook PC	DELL	E5530	24QPXW1	Non-Shielded, 0.8m
2	PoE	N/A	N/A	N/A	Non-Shielded, 1.8m

Test Mode		Mode 2			
Product		Manufacturer	Model No.	Serial No.	Power Cord
1	Notebook PC	DELL	E5530	24QPXW1	Non-Shielded, 0.8m

### 1.4. Configuration of Tested System

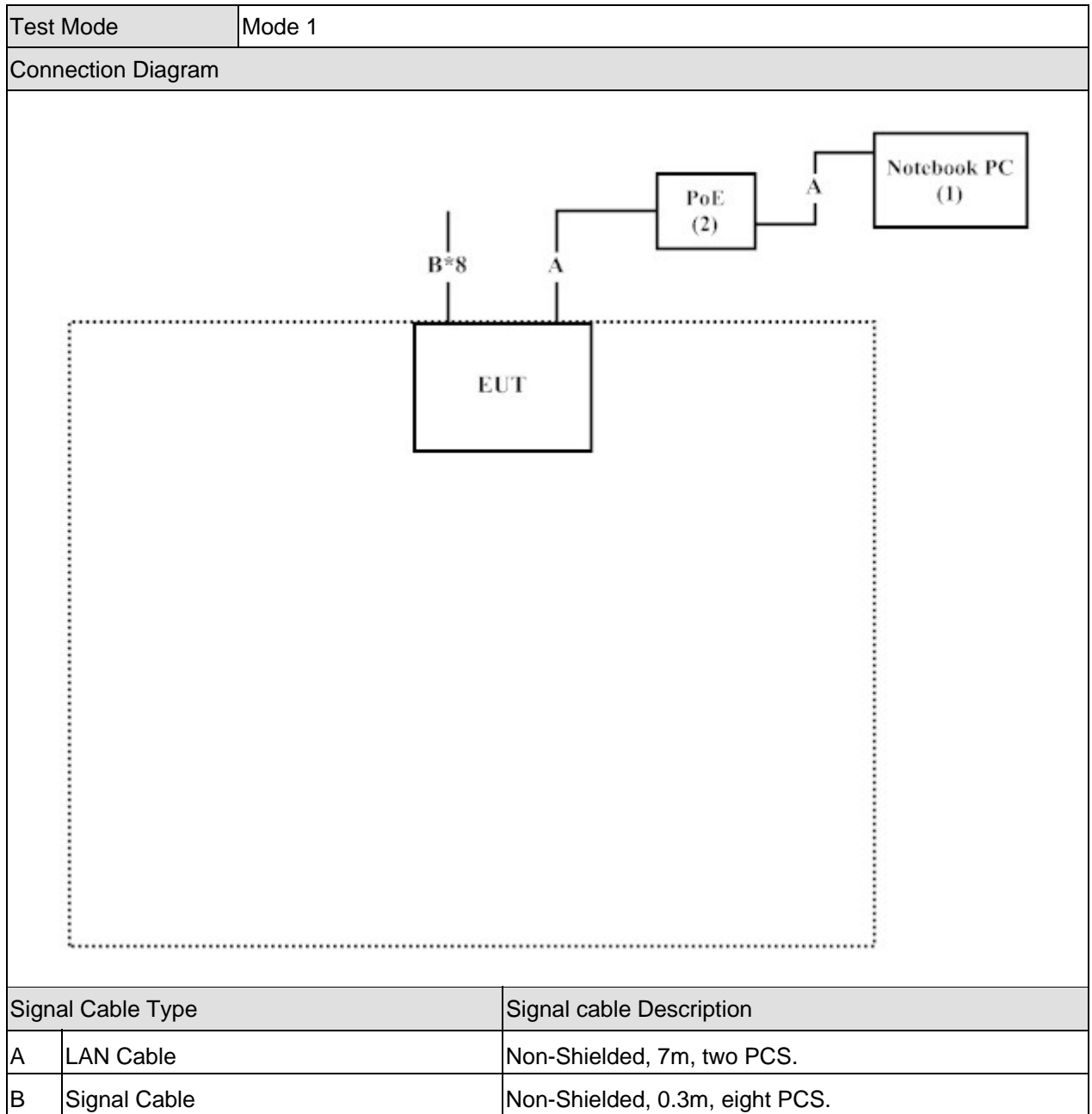

Test Mode		Mode 2	
Connection Diagram			
Signal Cable Type		Signal cable Description	
A	LAN Cable	Non-Shielded, 7m	
B	Signal Cable	Non-Shielded, 0.3m, eight PCS.	

### 1.5. EUT Exercise Software

1	Setup the EUT and simulators as shown on 1.4.
2	Turn on the power of all equipments.
3	All the features of the EUT operation normally.

## 2. Technical Test

### 2.1. Summary of Test Result

- No deviations from the test standards  
 Deviations from the test standards as below description:

Emission			
Performed Item	Normative References	Test Performed	Deviation
Conducted Emission	VCCI: 2015-04 Class A	Yes	No
Impedance Stabilization Network	VCCI: 2015-04 Class A	Yes	No
Radiated Emission	VCCI: 2015-04 Class A	Yes	No

## 2.2. List of Test Equipment

### Conducted Emission / SR1

Instrument	Manufacturer	Type No.	Serial No	Cal. Date
EMI Test Receiver	R&S	ESCS 30	100367	2015/12/21
LISN	R&S	ENV216	100085	2016/01/21
LISN	R&S	ENV216	101128	2015/12/02
Coaxial Cable	QTK(Arnist)	RG 400	LC016-RG	2015/06/24

### Impedance Stabilization Network / SR1

Instrument	Manufacturer	Type No.	Serial No	Cal. Date
Capacitive Voltage Probe	Schaffner	CVP2200A	18331	2015/10/30
EMI Test Receiver	R&S	ESCS 30	100367	2015/12/21
LISN	R&S	ENV216	100085	2016/01/21
LISN	R&S	ENV216	101128	2015/12/02
RF Current Probe	FCC	F-65 10KHz~1GHz	198	2015/11/03
Coaxial Cable	QTK(Arnist)	RG 400	LC016-RG	2015/06/24
Coupling Decoupling Network	Teseq	CDN ST08A	33998	2015/08/31
Coupling Decoupling Network	Teseq	CDN T800	30303	2015/03/30
BALANCED TELECOM ISN	FCC	FCC-TLISN-T2-02	20316	2015/08/03

### Radiated Emission / Site1

Instrument	Manufacturer	Type No.	Serial No	Cal. Date
Bilog Antenna	Schaffner Chase	CBL6112B	2905	2015/06/12
EMI Test Receiver	R&S	ESCS 30	100121	2015/04/13
Coaxial Cable	QTK(Arnist)	RG 214	LC001-RG	2015/06/15
Coaxial signal switch	Arnist	MP59B	6200436229	2015/06/15
Site1 NSA	QTK	N/A	N/A	2015/06/15

### Radiated Emission / CB7

Instrument	Manufacturer	Type No.	Serial No	Cal. Date
EMI Test Receiver	R&S	ESU26	100433	2015/09/03
Horn Antenna	SCHWARZBECK	9120D	576	2015/11/25
Pre-Amplifier	COM-POWER	PAM-118	443019	2015/07/14
CB7 VSWR	QTK	N/A	N/A	2015/06/25

### VCCI Test Site:

Test Item	Test Site	VCCI No.
Conducted Emission	SR1	C-2428
Conducted Emission (Telecommunication Port)	SR1	T-1473
Radiated Emission	Site 1	R-2231
Radiated Emission (Above 1GHz)	CB7(9x6x6_Chamber)	G-35

## 2.3. Measurement Uncertainty

### Conducted Emission

The measurement uncertainty is evaluated as  $\pm 2.26$  dB.

### Impedance Stabilization Network

The measurement uncertainty is evaluated as  $\pm 2.26$  dB.

### Radiated Emission

The measurement uncertainty is evaluated as  $\pm 3.19$  dB.

**2.4. Test Environment**

Performed Item	Items	Required	Actual
Conducted Emission	Temperature (°C)	15-35	19
	Humidity (%RH)	25-75	64
	Barometric pressure (mbar)	860-1060	950-1000
Impedance Stabilization Network	Temperature (°C)	15-35	19
	Humidity (%RH)	25-75	64
	Barometric pressure (mbar)	860-1060	950-1000
Radiated Emission	Temperature (°C)	15-35	15.5
	Humidity (%RH)	25-75	45
	Barometric pressure (mbar)	860-1060	950-1000

### 3. Conducted Emission

#### 3.1. Test Specification

According to EMC Standard : VCCI

#### 3.2. Test Setup

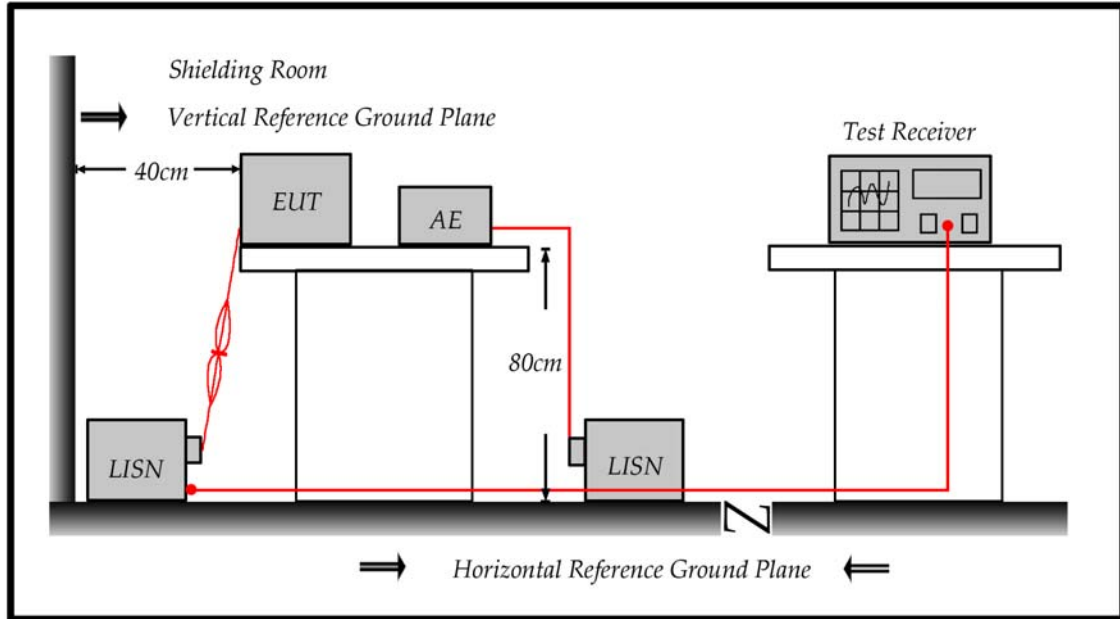

#### 3.3. Limit

Limits		
Frequency (MHz)	QP (dBuV)	AV (dBuV)
0.15 - 0.50	79	66
0.50-5.0	73	60
5.0 - 30	73	60

Remarks: In the above table, the tighter limit applies at the band edges.

### **3.4. Test Procedure**

The EUT and simulators are connected to the main power through a line impedance stabilization network (L.I.S.N.). This provides a 50 ohm /50uH coupling impedance for the measuring equipment. The peripheral devices are also connected to the main power through a LISN that provides a 50ohm/50uH coupling impedance with 50ohm termination.

(Please refers to the block diagram of the test setup and photographs.)

Both sides of A.C. line are checked for maximum conducted interference. In order to find the maximum emission, the relative positions of equipment and all of the interface cables must be changed according to VCCI on conducted measurement.

Conducted emissions were invested over the frequency range from 0.15MHz to 30MHz using a receiver bandwidth of 9kHz.

### **3.5. Deviation from Test Standard**

No deviation.

### 3.6. Test Result

Site : SR1	Time : 2016/01/30 - 17:00
Limit : CISPR_A_00M_QP	Margin : 13
EUT : Network Camera	Probe : ENV216_L1 - Line1
Power : AC 100V/50Hz	Note : Mode 2

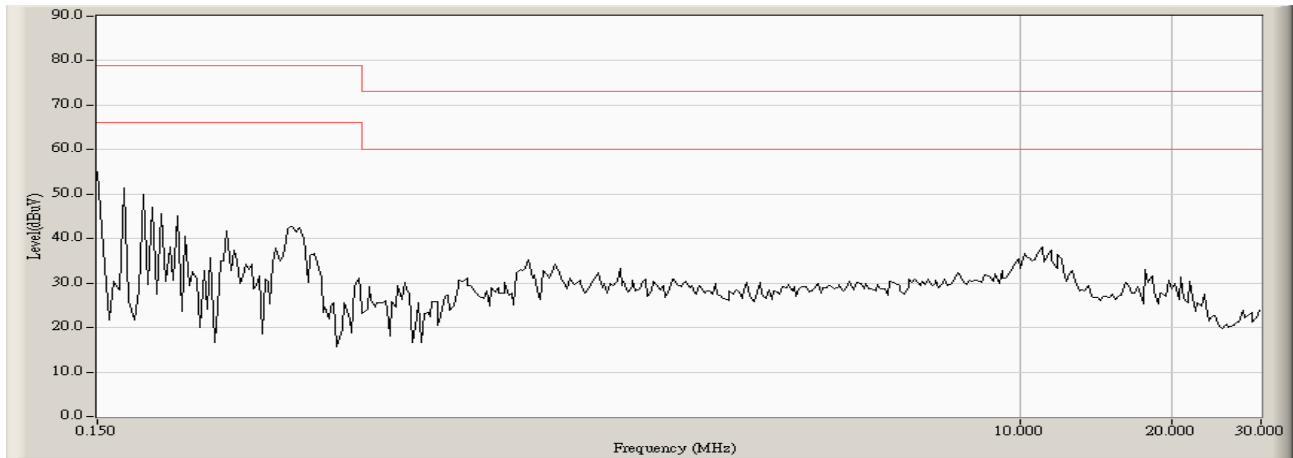

Site : SR1	Time : 2016/01/30 - 17:01
Limit : CISPR_A_00M_QP	Margin : 0
EUT : Network Camera	Probe : ENV216_L1 - Line1
Power : AC 100V/50Hz	Note : Mode 2

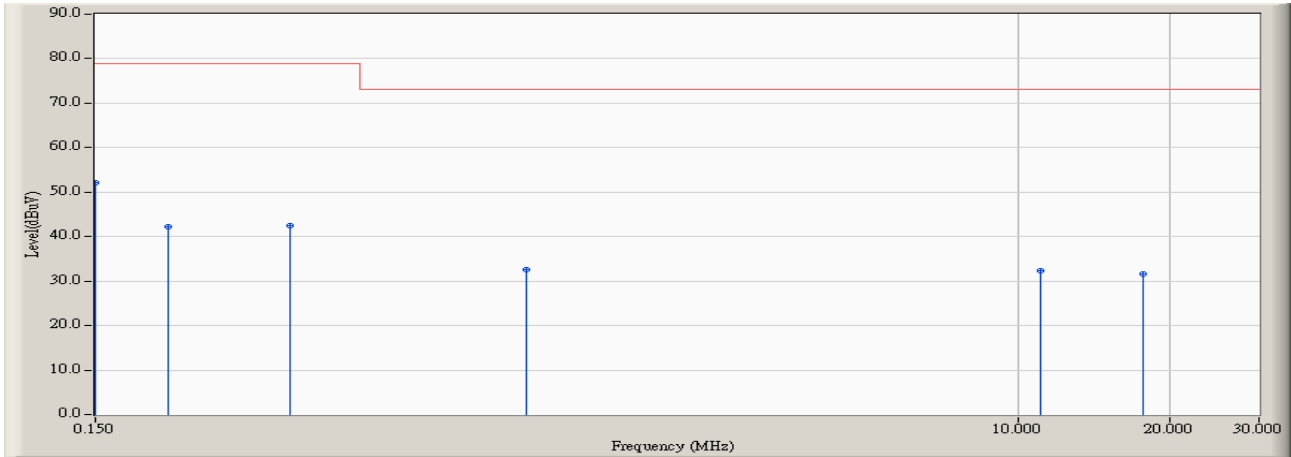

		Frequency (MHz)	Correct Factor (dB)	Reading Level (dBuV)	Measure Level (dBuV)	Margin (dB)	Limit (dBuV)	Detector Type
1	*	0.150	9.749	42.420	52.169	-26.831	79.000	QUASPEAK
2		0.209	9.739	32.390	42.129	-36.871	79.000	QUASPEAK
3		0.365	9.746	32.640	42.386	-36.614	79.000	QUASPEAK
4		1.068	9.778	22.780	32.558	-40.442	73.000	QUASPEAK
5		11.103	10.082	22.260	32.342	-40.658	73.000	QUASPEAK
6		17.693	10.201	21.360	31.561	-41.439	73.000	QUASPEAK

**Note:**

1. All Reading Levels are Quasi-Peak and average value.
2. " \* ", means this data is the worst emission level.
3. Measurement Level = Reading Level + Correct Factor

Site : SR1	Time : 2016/01/30 - 17:01
Limit : CISPR_A_00M_AV	Margin : 0
EUT : Network Camera	Probe : ENV216_L1 - Line1
Power : AC 100V/50Hz	Note : Mode 2

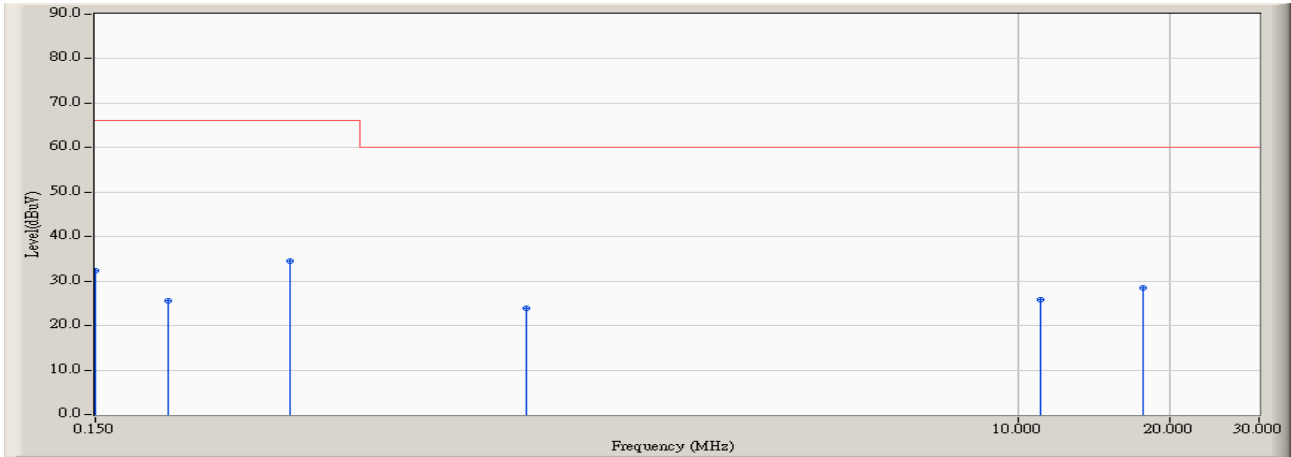

		Frequency (MHz)	Correct Factor (dB)	Reading Level (dBuV)	Measure Level (dBuV)	Margin (dB)	Limit (dBuV)	Detector Type
1		0.150	9.749	22.700	32.449	-33.551	66.000	AVERAGE
2		0.209	9.739	15.770	25.509	-40.491	66.000	AVERAGE
3	*	0.365	9.746	24.830	34.576	-31.424	66.000	AVERAGE
4		1.068	9.778	14.000	23.778	-36.222	60.000	AVERAGE
5		11.103	10.082	15.710	25.792	-34.208	60.000	AVERAGE
6		17.693	10.201	18.370	28.571	-31.429	60.000	AVERAGE

**Note:**

1. All Reading Levels are Quasi-Peak and average value.
2. " \* ", means this data is the worst emission level.
3. Measurement Level = Reading Level + Correct Factor

<b>Site : SR1</b>	<b>Time : 2016/01/30 - 17:02</b>
<b>Limit : CISPR_A_00M_QP</b>	<b>Margin : 13</b>
<b>EUT : Network Camera</b>	<b>Probe : ENV216_N - Line2</b>
<b>Power : AC 100V/50Hz</b>	<b>Note : Mode 2</b>

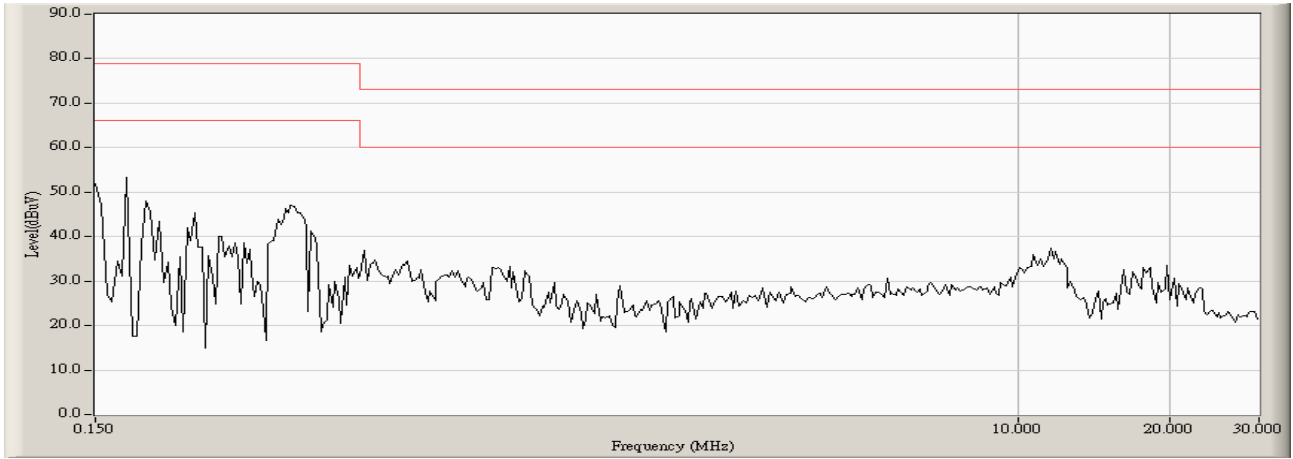

Site : SR1	Time : 2016/01/30 - 17:02
Limit : CISPR_A_00M_QP	Margin : 0
EUT : Network Camera	Probe : ENV216_N - Line2
Power : AC 100V/50Hz	Note : Mode 2

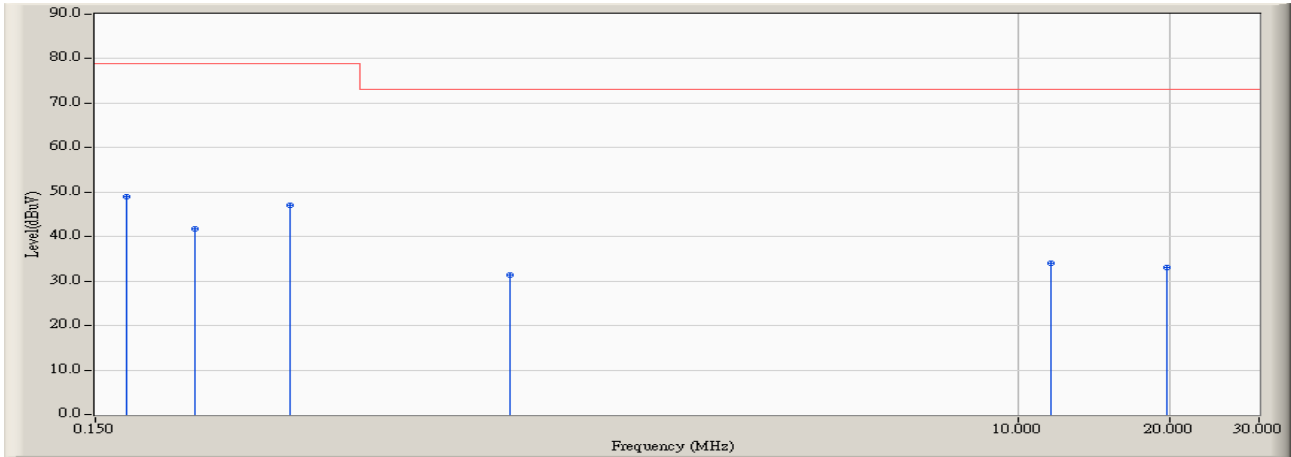

		Frequency (MHz)	Correct Factor (dB)	Reading Level (dBuV)	Measure Level (dBuV)	Margin (dB)	Limit (dBuV)	Detector Type
1	*	0.173	9.737	39.260	48.997	-30.003	79.000	QUASPEAK
2		0.236	9.740	32.120	41.860	-37.140	79.000	QUASPEAK
3		0.365	9.736	37.420	47.156	-31.844	79.000	QUASPEAK
4		0.994	9.765	21.500	31.265	-41.735	73.000	QUASPEAK
5		11.646	10.132	23.970	34.102	-38.898	73.000	QUASPEAK
6		19.709	10.359	22.620	32.979	-40.021	73.000	QUASPEAK

**Note:**

1. All Reading Levels are Quasi-Peak and average value.
2. " \* ", means this data is the worst emission level.
3. Measurement Level = Reading Level + Correct Factor

Site : SR1	Time : 2016/01/30 - 17:02
Limit : CISPR_A_00M_AV	Margin : 0
EUT : Network Camera	Probe : ENV216_N - Line2
Power : AC 100V/50Hz	Note : Mode 2

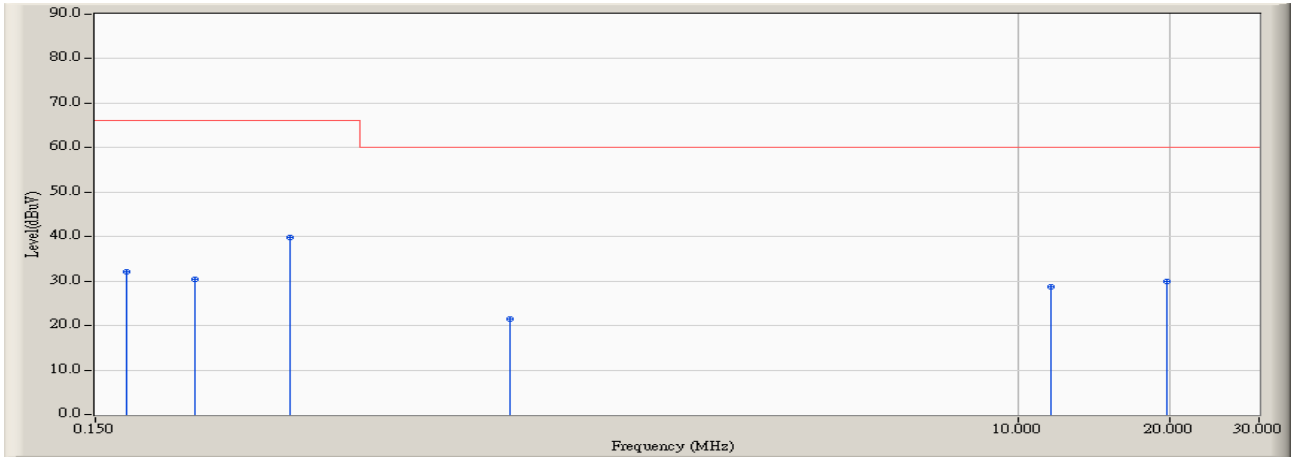

	Frequency (MHz)	Correct Factor (dB)	Reading Level (dBuV)	Measure Level (dBuV)	Margin (dB)	Limit (dBuV)	Detector Type
1	0.173	9.737	22.250	31.987	-34.013	66.000	AVERAGE
2	0.236	9.740	20.670	30.410	-35.590	66.000	AVERAGE
3	* 0.365	9.736	30.070	39.806	-26.194	66.000	AVERAGE
4	0.994	9.765	11.760	21.525	-38.475	60.000	AVERAGE
5	11.646	10.132	18.650	28.782	-31.218	60.000	AVERAGE
6	19.709	10.359	19.580	29.939	-30.061	60.000	AVERAGE

**Note:**

1. All Reading Levels are Quasi-Peak and average value.
2. " \* ", means this data is the worst emission level.
3. Measurement Level = Reading Level + Correct Factor

### 3.7. Test Photograph

Test Mode : Mode 2: IB9371-HT, DC MODE

Description : Front View of Conducted Test



Test Mode : Mode 2: IB9371-HT, DC MODE

Description : Back View of Conducted Test



Test Mode : Mode 2: IB9371-HT, DC MODE

Description : Back View of Conducted Test



## 4. Conducted Emissions (Telecommunication Ports)

### 4.1. Test Specification

According to EMC Standard : VCCI

### 4.2. Test Setup

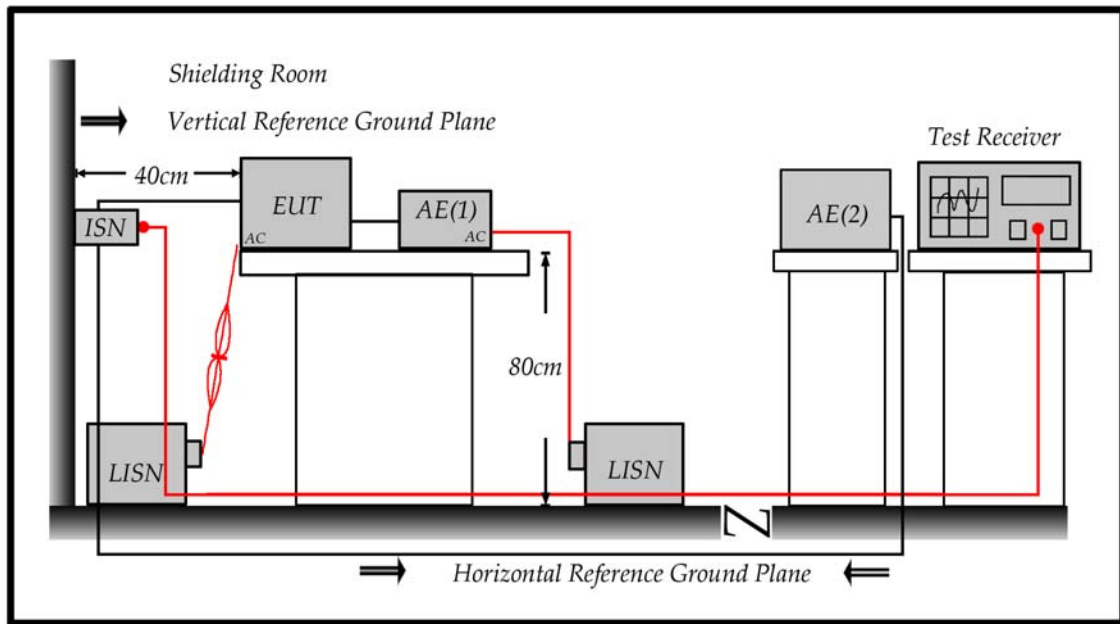

### 4.3. Limit

Limits		
Frequency (MHz)	QP (dBuV)	AV (dBuV)
0.15 - 0.50	97 – 87	84 – 74
0.50 - 30	87	74

Remarks:

The limit decreases linearly with the logarithm of the frequency in the range 0.15 MHz~0.50 MHz.

#### **4.4. Test Procedure**

##### **Telecommunication Port:**

The mains voltage shall be supplied to the EUT via the LISN when the measurement of telecommunication port is performed. The common mode disturbances at the telecommunication port shall be connected to the ISN, which is 150 ohm impedance.

Both alternative cables are tested related to the LCL requested. The measurement range is from 150kHz to 30MHz. The bandwidth of measurement is set to 9kHz.

The 75dB LCL ISN is used for cat. 6 cable, the 65dB LCL ISN is used for cat. 5 cable, 55dB LCL ISN is used for cat. 3.

#### **4.5. Deviation from Test Standard**

No deviation.

### 4.6. Test Result

Site : SR1	Time : 2016/01/30 - 16:47
Limit : ISN_Voltage_A_00M_QP	Margin : 13
EUT : Network Camera	Probe : TESEQ_T8 - Line1
Power : Power By PoE	Note : Mode 1,ISN 10M

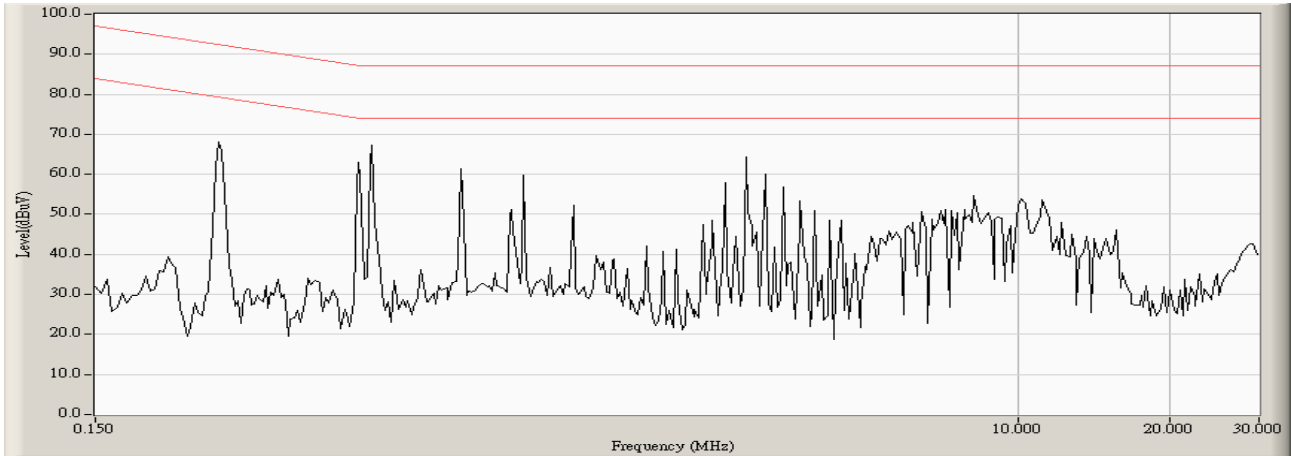

<b>Site : SR1</b>	<b>Time : 2016/01/30 - 16:48</b>
<b>Limit : ISN_Voltage_A_00M_QP</b>	<b>Margin : 0</b>
<b>EUT : Network Camera</b>	<b>Probe : TESEQ_T8 - Line1</b>
<b>Power : Power By PoE</b>	<b>Note : Mode 1,ISN 10M</b>

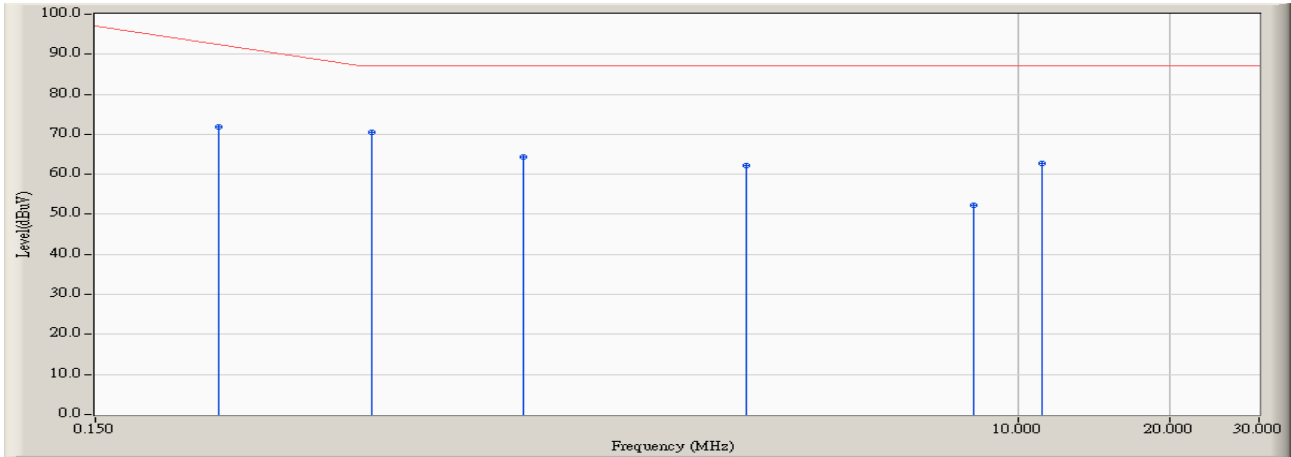

		Frequency (MHz)	Correct Factor (dB)	Reading Level (dBuV)	Measure Level (dBuV)	Margin (dB)	Limit (dBuV)	Detector Type
1		0.263	10.138	61.810	71.948	-21.823	93.771	QUASIPeAK
2	*	0.529	9.937	60.440	70.377	-16.623	87.000	QUASIPeAK
3		1.056	9.874	54.590	64.464	-22.536	87.000	QUASIPeAK
4		2.908	9.862	52.410	62.272	-24.728	87.000	QUASIPeAK
5		8.205	9.922	42.390	52.312	-34.688	87.000	QUASIPeAK
6		11.177	9.963	52.890	62.853	-24.147	87.000	QUASIPeAK

**Note:**

1. All Reading Levels are Quasi-Peak and average value.
2. " \* ", means this data is the worst emission level.
3. Measurement Level = Reading Level + Correct Factor

Site : SR1	Time : 2016/01/30 - 16:48
Limit : ISN_Voltage_A_00M_AV	Margin : 0
EUT : Network Camera	Probe : TESEQ_T8 - Line1
Power : Power By PoE	Note : Mode 1,ISN 10M

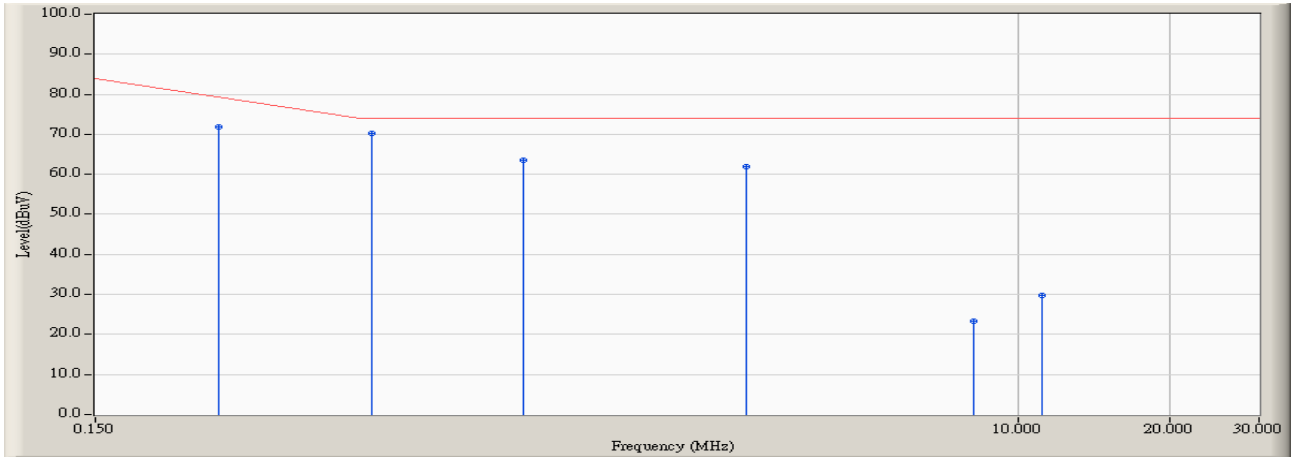

		Frequency (MHz)	Correct Factor (dB)	Reading Level (dBuV)	Measure Level (dBuV)	Margin (dB)	Limit (dBuV)	Detector Type
1		0.263	10.138	61.710	71.848	-8.923	80.771	AVERAGE
2	*	0.529	9.937	60.370	70.307	-3.693	74.000	AVERAGE
3		1.056	9.874	53.620	63.494	-10.506	74.000	AVERAGE
4		2.908	9.862	52.000	61.862	-12.138	74.000	AVERAGE
5		8.205	9.922	13.400	23.322	-50.678	74.000	AVERAGE
6		11.177	9.963	19.780	29.743	-44.257	74.000	AVERAGE

**Note:**

1. All Reading Levels are Quasi-Peak and average value.
2. " \* ", means this data is the worst emission level.
3. Measurement Level = Reading Level + Correct Factor

<b>Site : SR1</b>	<b>Time : 2016/01/30 - 16:50</b>
<b>Limit : ISN_Voltage_A_00M_QP</b>	<b>Margin : 13</b>
<b>EUT : Network Camera</b>	<b>Probe : TESEQ_T8 - Line1</b>
<b>Power : Power By PoE</b>	<b>Note : Mode 1,ISN 100M</b>

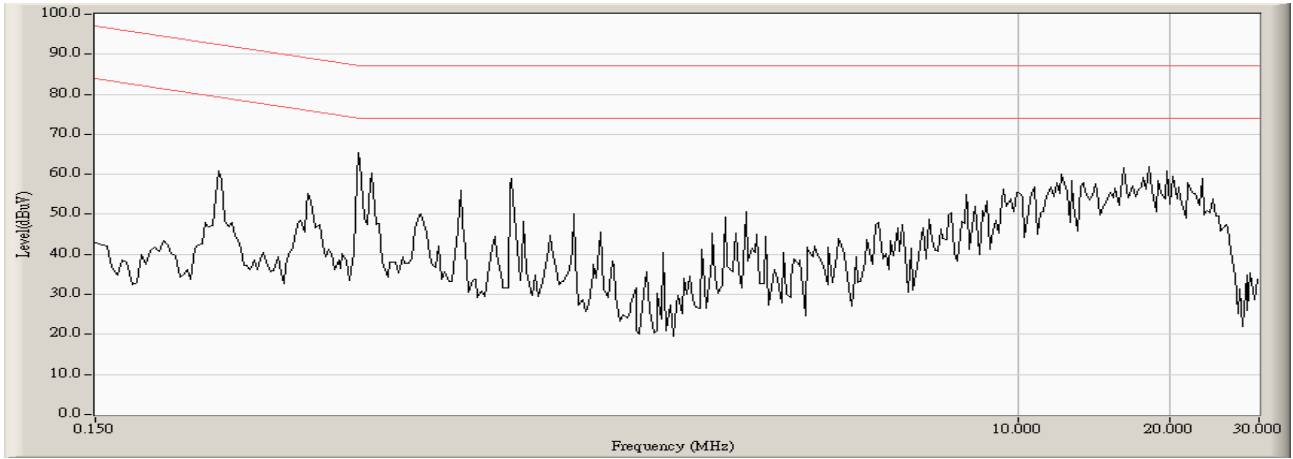

Site : SR1	Time : 2016/01/30 - 16:51
Limit : ISN_Voltage_A_00M_QP	Margin : 0
EUT : Network Camera	Probe : TESEQ_T8 - Line1
Power : Power By PoE	Note : Mode 1,ISN 100M

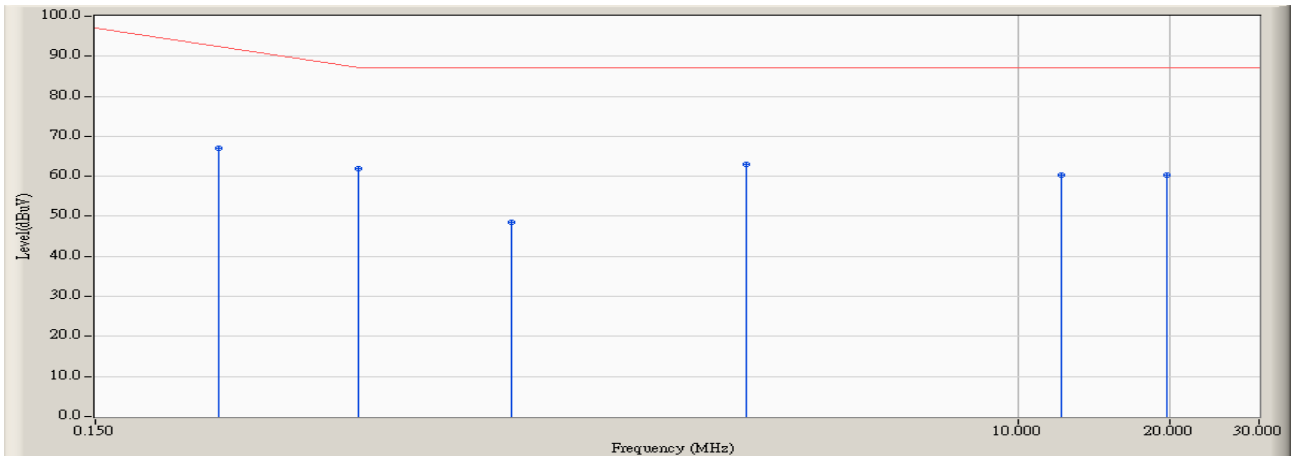

		Frequency (MHz)	Correct Factor (dB)	Reading Level (dBuV)	Measure Level (dBuV)	Margin (dB)	Limit (dBuV)	Detector Type
1		0.263	10.138	56.910	67.048	-26.723	93.771	QUASIPeAK
2		0.498	9.949	51.990	61.939	-25.118	87.057	QUASIPeAK
3		0.998	9.875	38.650	48.525	-38.475	87.000	QUASIPeAK
4	*	2.904	9.863	53.210	63.073	-23.927	87.000	QUASIPeAK
5		12.197	9.982	50.240	60.222	-26.778	87.000	QUASIPeAK
6		19.709	10.119	50.190	60.309	-26.691	87.000	QUASIPeAK

**Note:**

1. All Reading Levels are Quasi-Peak and average value.
2. " \* ", means this data is the worst emission level.
3. Measurement Level = Reading Level + Correct Factor

Site : SR1	Time : 2016/01/30 - 16:51
Limit : ISN_Voltage_A_00M_AV	Margin : 0
EUT : Network Camera	Probe : TESEQ_T8 - Line1
Power : Power By PoE	Note : Mode 1,ISN 100M

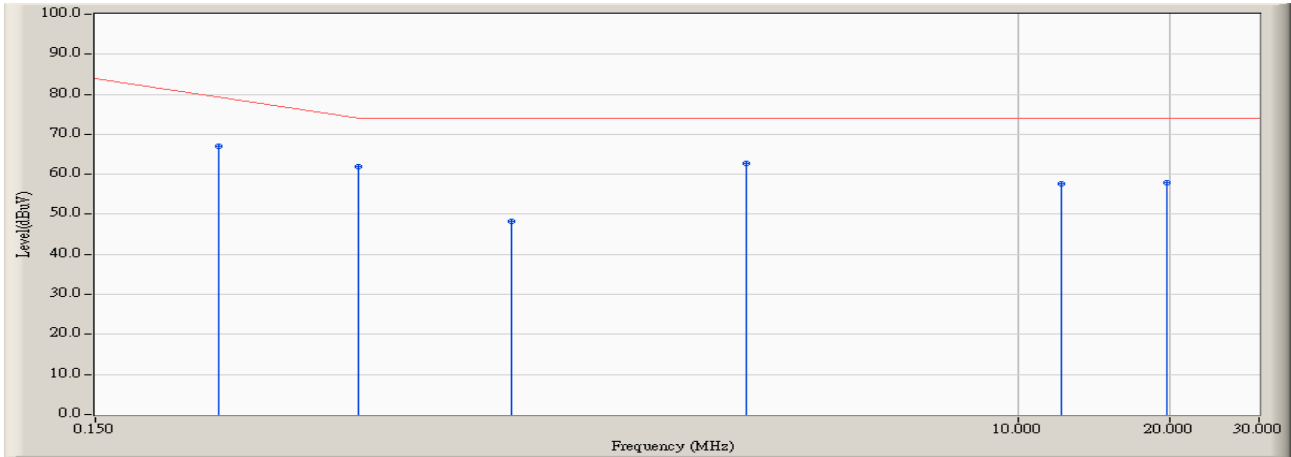

		Frequency (MHz)	Correct Factor (dB)	Reading Level (dBuV)	Measure Level (dBuV)	Margin (dB)	Limit (dBuV)	Detector Type
1		0.263	10.138	56.760	66.898	-13.873	80.771	AVERAGE
2		0.498	9.949	51.980	61.929	-12.128	74.057	AVERAGE
3		0.998	9.875	38.440	48.315	-25.685	74.000	AVERAGE
4	*	2.904	9.863	52.830	62.693	-11.307	74.000	AVERAGE
5		12.197	9.982	47.530	57.512	-16.488	74.000	AVERAGE
6		19.709	10.119	47.720	57.839	-16.161	74.000	AVERAGE

**Note:**

1. All Reading Levels are Quasi-Peak and average value.
2. " \* ", means this data is the worst emission level.
3. Measurement Level = Reading Level + Correct Factor

<b>Site : SR1</b>	<b>Time : 2016/01/30 - 16:54</b>
<b>Limit : ISN_Voltage_A_00M_QP</b>	<b>Margin : 13</b>
<b>EUT : Network Camera</b>	<b>Probe : TESEQ_T8 - Line1</b>
<b>Power : AC 100V/50Hz</b>	<b>Note : Mode 2,ISN 10M</b>

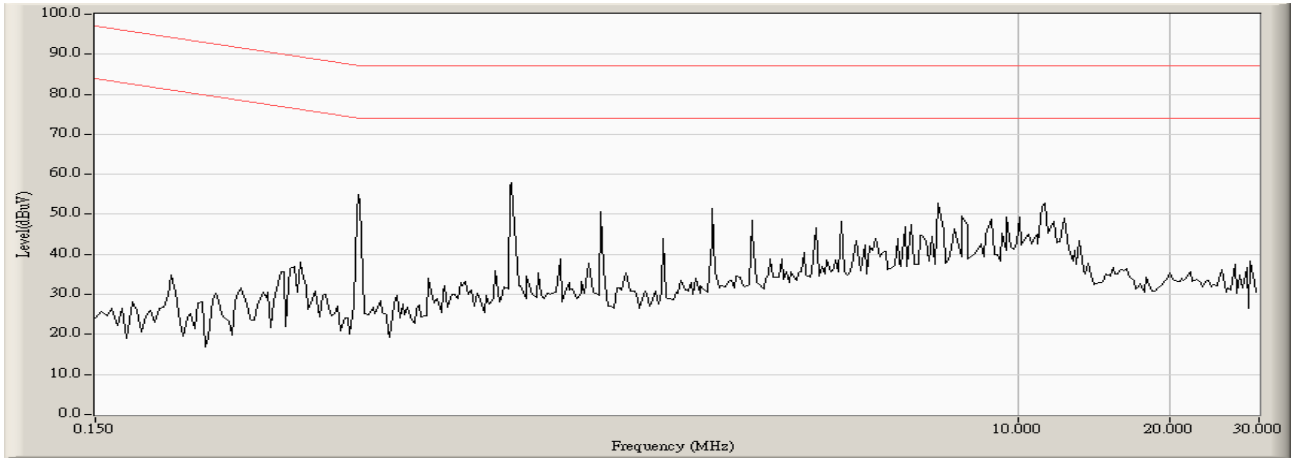

Site : SR1	Time : 2016/01/30 - 16:57
Limit : ISN_Voltage_A_00M_QP	Margin : 0
EUT : Network Camera	Probe : TESEQ_T8 - Line1
Power : AC 100V/50Hz	Note : Mode 2,ISN 10M

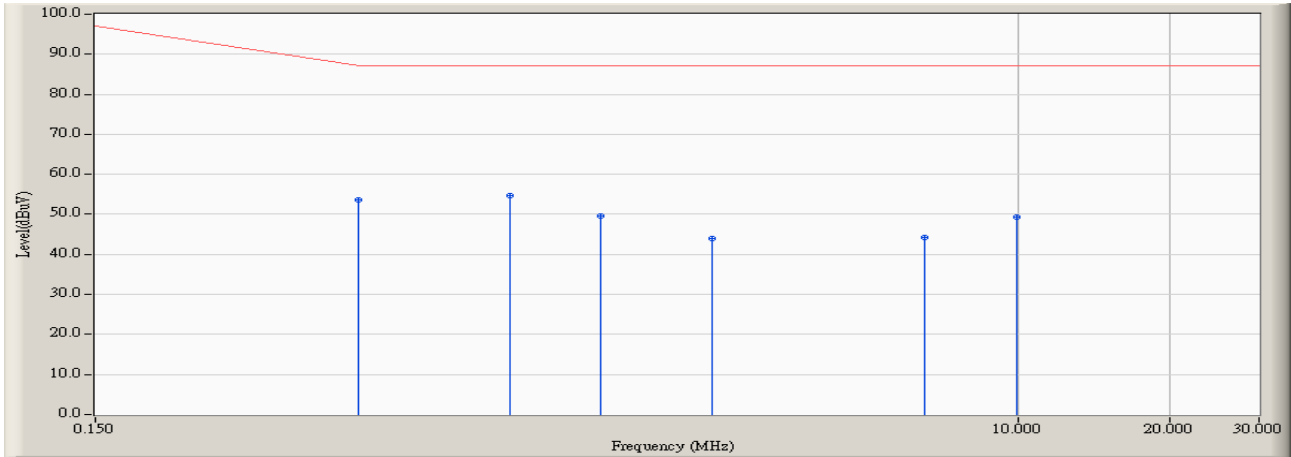

		Frequency (MHz)	Correct Factor (dB)	Reading Level (dBuV)	Measure Level (dBuV)	Margin (dB)	Limit (dBuV)	Detector Type
1		0.498	9.949	43.770	53.719	-33.338	87.057	QUASIPeAK
2	*	0.994	9.875	44.800	54.675	-32.325	87.000	QUASIPeAK
3		1.494	9.867	39.730	49.597	-37.403	87.000	QUASIPeAK
4		2.486	9.856	34.020	43.876	-43.124	87.000	QUASIPeAK
5		6.556	9.899	34.410	44.309	-42.691	87.000	QUASIPeAK
6		9.955	9.941	39.360	49.301	-37.699	87.000	QUASIPeAK

**Note:**

1. All Reading Levels are Quasi-Peak and average value.
2. " \* ", means this data is the worst emission level.
3. Measurement Level = Reading Level + Correct Factor

Site : SR1	Time : 2016/01/30 - 16:57
Limit : ISN_Voltage_A_00M_AV	Margin : 0
EUT : Network Camera	Probe : TESEQ_T8 - Line1
Power : AC 100V/50Hz	Note : Mode 2,ISN 10M

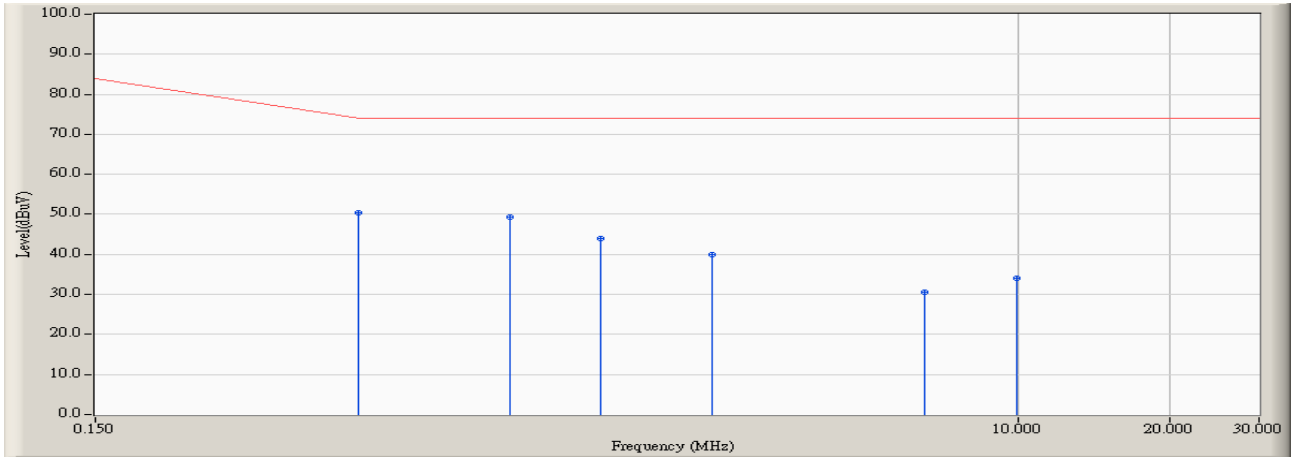

		Frequency (MHz)	Correct Factor (dB)	Reading Level (dBuV)	Measure Level (dBuV)	Margin (dB)	Limit (dBuV)	Detector Type
1	*	0.498	9.949	40.580	50.529	-23.528	74.057	AVERAGE
2		0.994	9.875	39.390	49.265	-24.735	74.000	AVERAGE
3		1.494	9.867	34.220	44.087	-29.913	74.000	AVERAGE
4		2.486	9.856	30.160	40.016	-33.984	74.000	AVERAGE
5		6.556	9.899	20.680	30.579	-43.421	74.000	AVERAGE
6		9.955	9.941	24.190	34.131	-39.869	74.000	AVERAGE

**Note:**

1. All Reading Levels are Quasi-Peak and average value.
2. " \* ", means this data is the worst emission level.
3. Measurement Level = Reading Level + Correct Factor

<b>Site : SR1</b>	<b>Time : 2016/01/30 - 16:58</b>
<b>Limit : ISN_Voltage_A_00M_QP</b>	<b>Margin : 13</b>
<b>EUT : Network Camera</b>	<b>Probe : TESEQ_T8 - Line1</b>
<b>Power : AC 100V/50Hz</b>	<b>Note : Mode 2,ISN 100M</b>

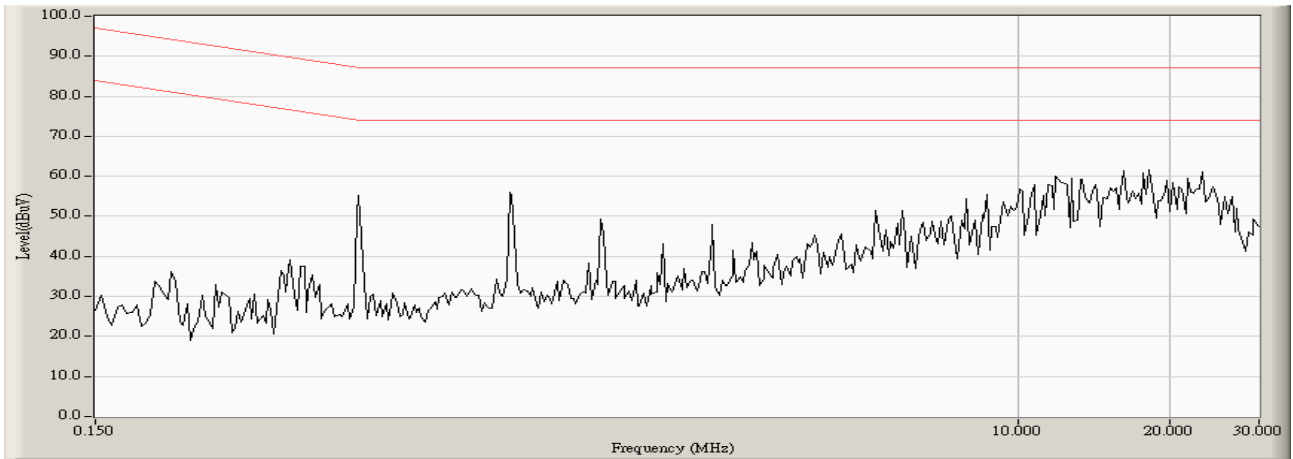

Site : SR1	Time : 2016/01/30 - 16:59
Limit : ISN_Voltage_A_00M_QP	Margin : 0
EUT : Network Camera	Probe : TESEQ_T8 - Line1
Power : AC 100V/50Hz	Note : Mode 2,ISN 100M

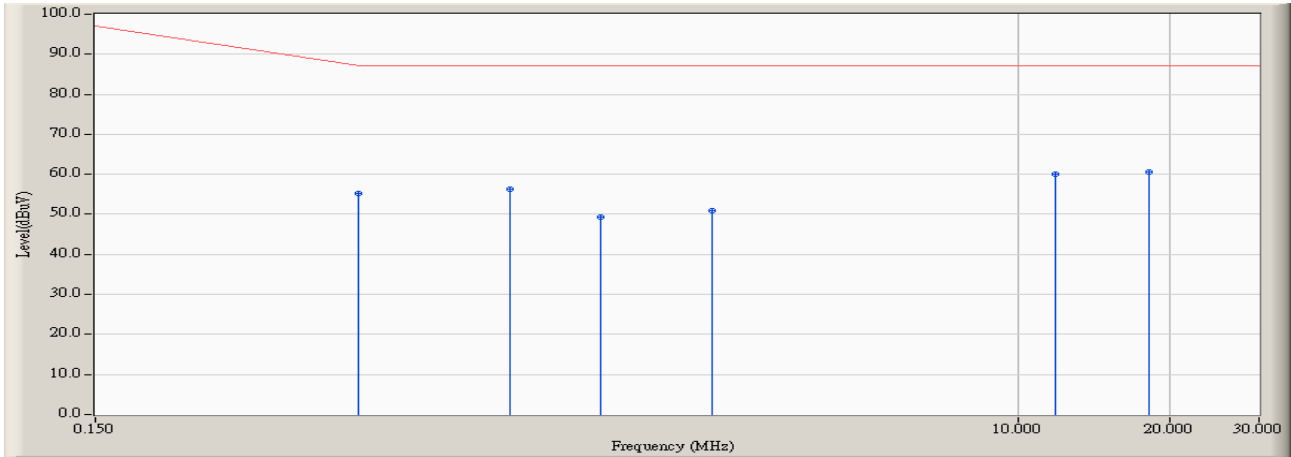

		Frequency (MHz)	Correct Factor (dB)	Reading Level (dBuV)	Measure Level (dBuV)	Margin (dB)	Limit (dBuV)	Detector Type
1		0.498	9.949	45.390	55.339	-31.718	87.057	QUASIPeAK
2		0.994	9.875	46.470	56.345	-30.655	87.000	QUASIPeAK
3		1.494	9.867	39.380	49.247	-37.753	87.000	QUASIPeAK
4		2.490	9.856	41.020	50.876	-36.124	87.000	QUASIPeAK
5		11.892	9.976	49.990	59.966	-27.034	87.000	QUASIPeAK
6	*	18.244	10.096	50.600	60.696	-26.304	87.000	QUASIPeAK

**Note:**

1. All Reading Levels are Quasi-Peak and average value.
2. " \* ", means this data is the worst emission level.
3. Measurement Level = Reading Level + Correct Factor

<b>Site : SR1</b>	<b>Time : 2016/01/30 - 16:59</b>
<b>Limit : ISN_Voltage_A_00M_AV</b>	<b>Margin : 0</b>
<b>EUT : Network Camera</b>	<b>Probe : TESEQ_T8 - Line1</b>
<b>Power : AC 100V/50Hz</b>	<b>Note : Mode 2,ISN 100M</b>

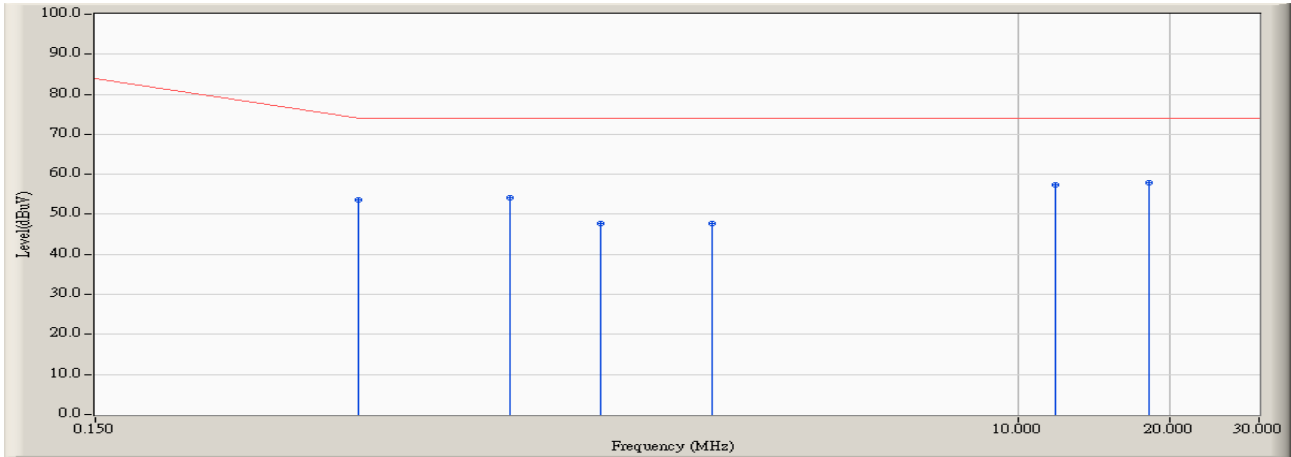

		Frequency (MHz)	Correct Factor (dB)	Reading Level (dBuV)	Measure Level (dBuV)	Margin (dB)	Limit (dBuV)	Detector Type
1		0.498	9.949	43.750	53.699	-20.358	74.057	AVERAGE
2		0.994	9.875	44.250	54.125	-19.875	74.000	AVERAGE
3		1.494	9.867	37.840	47.707	-26.293	74.000	AVERAGE
4		2.490	9.856	37.890	47.746	-26.254	74.000	AVERAGE
5		11.892	9.976	47.470	57.446	-16.554	74.000	AVERAGE
6	*	18.244	10.096	47.920	58.016	-15.984	74.000	AVERAGE

**Note:**

1. All Reading Levels are Quasi-Peak and average value.
2. " \* ", means this data is the worst emission level.
3. Measurement Level = Reading Level + Correct Factor

#### 4.7. Test Photograph

Test Mode : Mode 1: IB9371-HT, Poe MODE

Description : Front View of ISN Test



Test Mode : Mode 1: IB9371-HT, Poe MODE

Description : Back View of ISN Test



Test Mode : Mode 1: IB9371-HT, Poe MODE

Description : Back View of ISN Test



Test Mode : Mode 2: IB9371-HT, DC MODE

Description : Front View of ISN Test



Test Mode : Mode 2: IB9371-HT, DC MODE

Description : Back View of ISN Test



Test Mode : Mode 2: IB9371-HT, DC MODE

Description : Back View of ISN Test



## 5. Radiated Emission

### 5.1. Test Specification

According to EMC Standard : VCCI

### 5.2. Test Setup

Under 1GHz Test Setup:

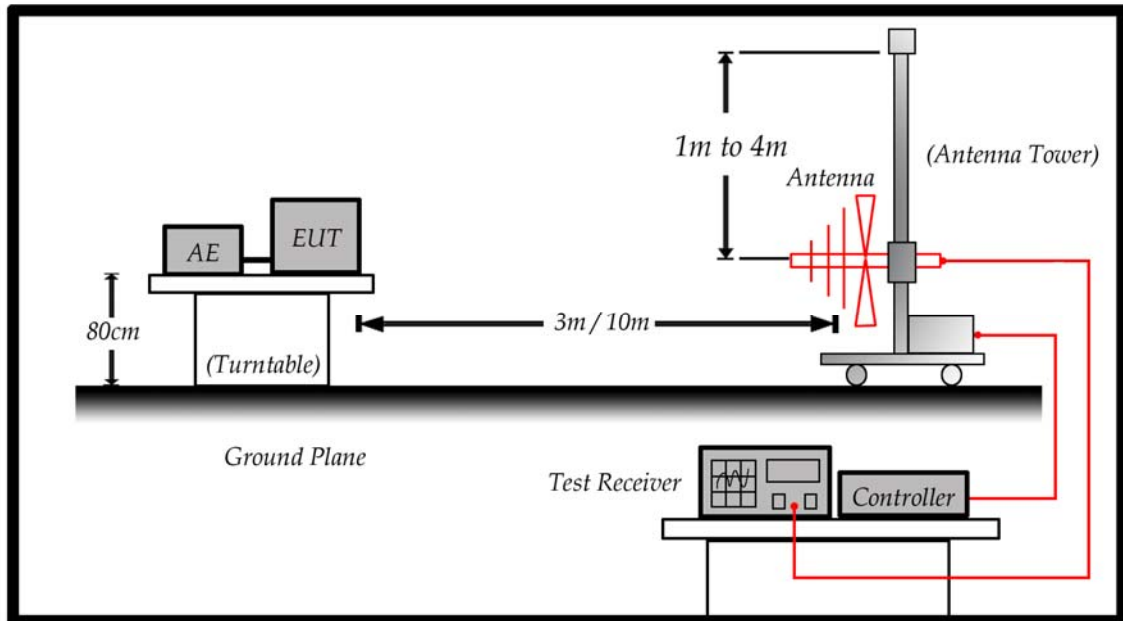

Above 1GHz Test Setup:

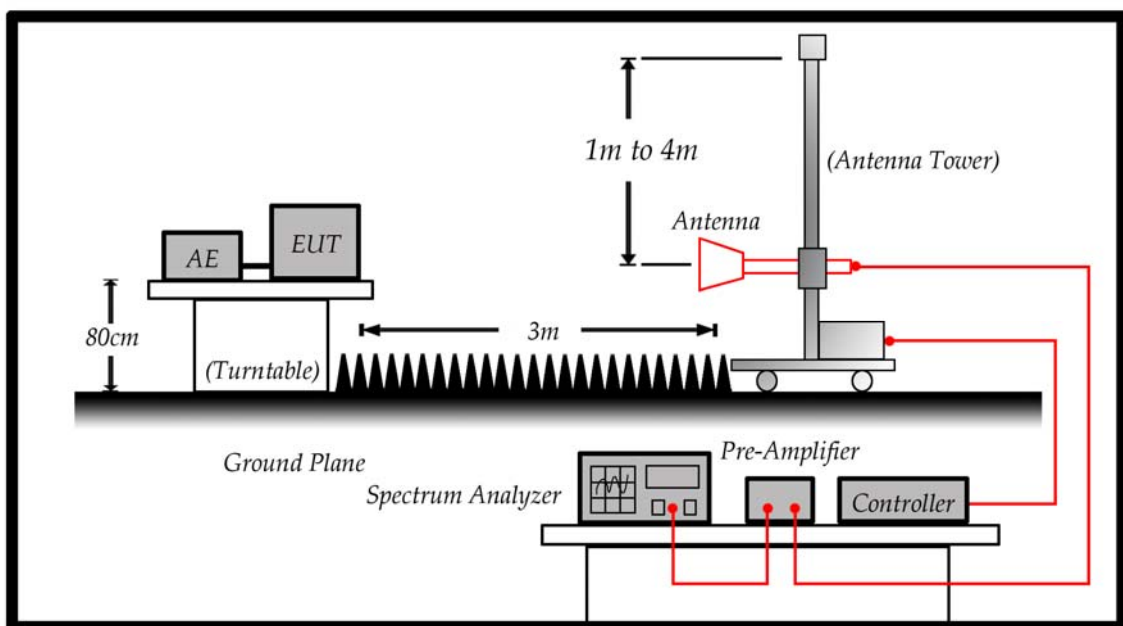

**5.3. Limit**

Limits		
Frequency (MHz)	Distance (m)	dBuV/m
30 – 230	10	40
230 – 1000	10	47

Remark:

1. The tighter limit shall apply at the edge between two frequency bands.
2. Distance refers to the distance in meters between the measuring instrument antenna and the closed point of any part of the device or system.

**5.4. Test Procedure**

The EUT and its simulators are placed on a turn table which is 0.8 meter above ground. The turn table can rotate 360 degrees to determine the position of the maximum emission level. The EUT was positioned such that the distance from antenna to the EUT was 10 meters. The antenna can move up and down between 1 meter and 4 meters to find out the maximum emission level.

All cable leaving the table-top EUT for a connection outside the test site (for example, mains cable, telephone lines, connections to auxiliary equipment located outside the test area) shall be fitted with ferrite clamps placed on the floor at the point where the cable reached the floor. Both horizontal and vertical polarization of the antenna are set on measurement. In order to find the maximum emission, all of the interface cables must be manipulated according to VCCI on radiated measurement.

Radiated emissions were investigated over the frequency range from 30MHz to 1GHz using a receiver bandwidth of 120kHz. Radiated was performed at an antenna to EUT distance of 10 meters.

**5.5. Deviation from Test Standard**

No deviation.

### 5.6. Test Result

Site : site1	Time : 2016/01/31 - 02:35
Limit : CISPR_A_10M_QP	Margin : 6
EUT : Network Camera	Probe : Site1_CBL6112_10M_1506 - HORIZONTAL
Power : Power By PoE	Note : Mode 1

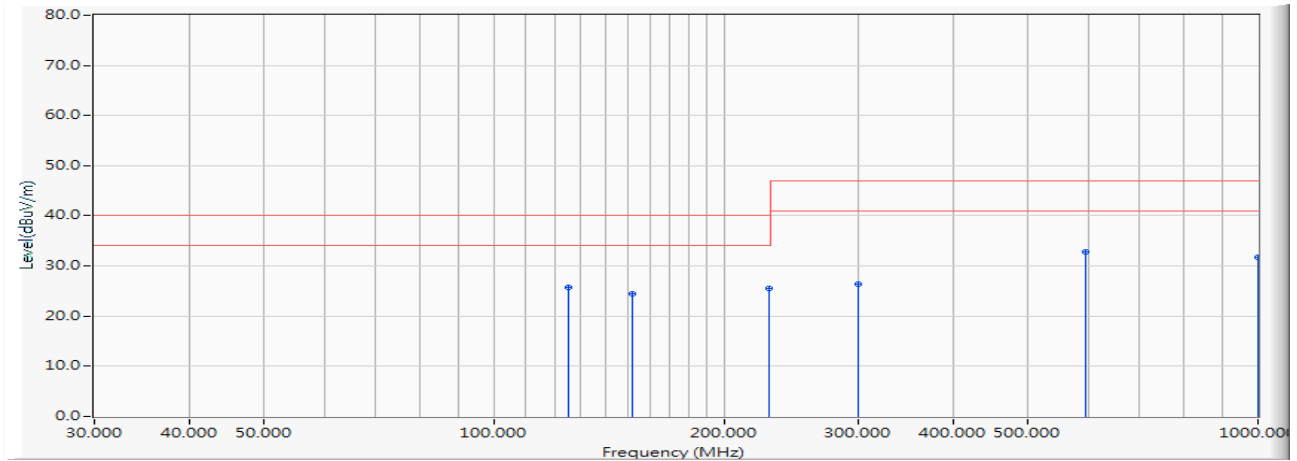

		Frequency (MHz)	Correct Factor (dB)	Reading Level (dBuV)	Measure Level (dBuV/m)	Margin (dB)	Limit (dBuV/m)	Detector Type
1		125.000	14.392	11.400	25.792	-14.208	40.000	QUASPEAK
2		151.500	12.833	11.600	24.432	-15.568	40.000	QUASPEAK
3		229.250	13.177	12.300	25.477	-14.523	40.000	QUASPEAK
4		300.000	16.907	9.500	26.407	-20.593	47.000	QUASPEAK
5	*	594.010	24.070	8.800	32.870	-14.130	47.000	QUASPEAK
6		1000.000	29.640	2.100	31.740	-15.260	47.000	QUASPEAK

**Note:**

1. All Readings below 1GHz are Quasi-Peak, above are performed with peak and/or average measurements as necessary.
2. " \* ", means this data is the worst emission level.
3. Measurement Level = Reading Level + Correct Factor

Site : site1	Time : 2016/01/31 - 02:35
Limit : CISPR_A_10M_QP	Margin : 6
EUT : Network Camera	Probe : Site1_CBL6112_10M_1506 - VERTICAL
Power : Power By PoE	Note : Mode 1

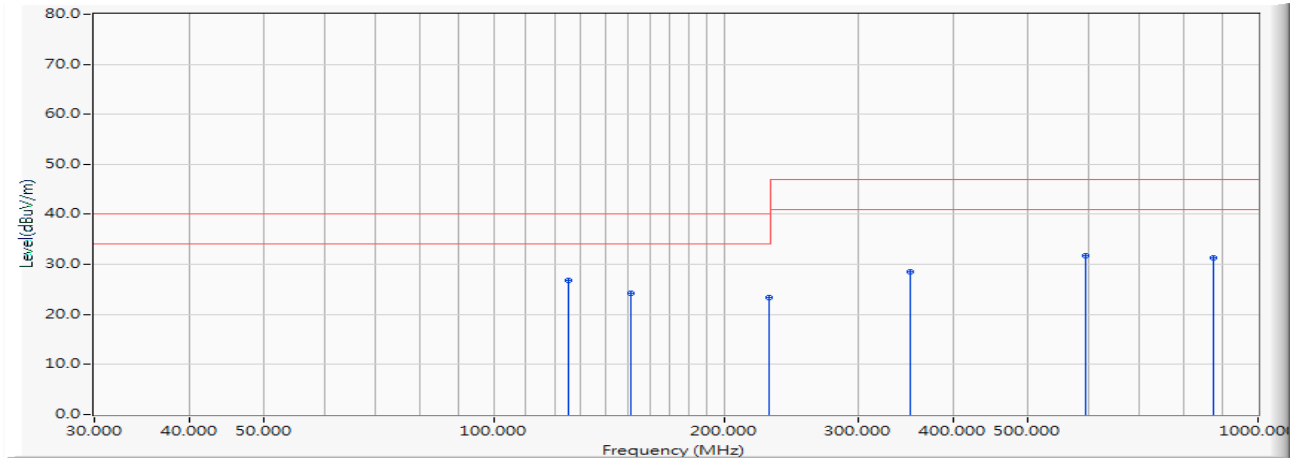

		Frequency (MHz)	Correct Factor (dB)	Reading Level (dBuV)	Measure Level (dBuV/m)	Margin (dB)	Limit (dBuV/m)	Detector Type
1	*	125.000	14.392	12.400	26.792	-13.208	40.000	QUASPEAK
2		151.250	12.840	11.300	24.140	-15.860	40.000	QUASPEAK
3		229.250	13.177	10.200	23.377	-16.623	40.000	QUASPEAK
4		350.000	18.377	10.200	28.577	-18.423	47.000	QUASPEAK
5		594.010	24.070	7.700	31.770	-15.230	47.000	QUASPEAK
6		875.000	27.560	3.700	31.260	-15.740	47.000	QUASPEAK

**Note:**

1. All Readings below 1GHz are Quasi-Peak, above are performed with peak and/or average measurements as necessary.
2. " \* ", means this data is the worst emission level.
3. Measurement Level = Reading Level + Correct Factor

Site : site1	Time : 2016/01/31 - 03:14
Limit : CISPR_A_10M_QP	Margin : 6
EUT : Network Camera	Probe : Site1_CBL6112_10M_1506 - HORIZONTAL
Power : AC 100V/50Hz	Note : Mode 2

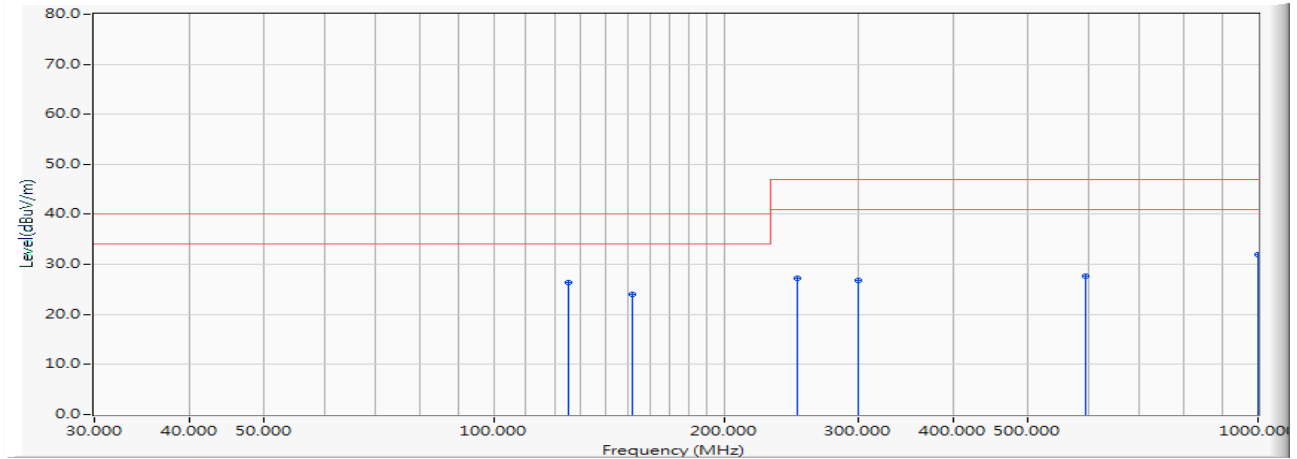

		Frequency (MHz)	Correct Factor (dB)	Reading Level (dBuV)	Measure Level (dBuV/m)	Margin (dB)	Limit (dBuV/m)	Detector Type
1	*	125.000	14.392	12.000	26.392	-13.608	40.000	QUASPEAK
2		151.880	12.820	11.300	24.121	-15.879	40.000	QUASPEAK
3		250.000	15.716	11.500	27.216	-19.784	47.000	QUASPEAK
4		300.000	16.907	9.800	26.707	-20.293	47.000	QUASPEAK
5		594.010	24.070	3.600	27.670	-19.330	47.000	QUASPEAK
6		1000.000	29.640	2.400	32.040	-14.960	47.000	QUASPEAK

**Note:**

1. All Readings below 1GHz are Quasi-Peak, above are performed with peak and/or average measurements as necessary.
2. " \* ", means this data is the worst emission level.
3. Measurement Level = Reading Level + Correct Factor

Site : site1	Time : 2016/01/31 - 03:34
Limit : CISPR_A_10M_QP	Margin : 0
EUT : Network Camera	Probe : Site1_CBL6112_10M_1506 - VERTICAL
Power : AC 100V/50Hz	Note : Mode 2

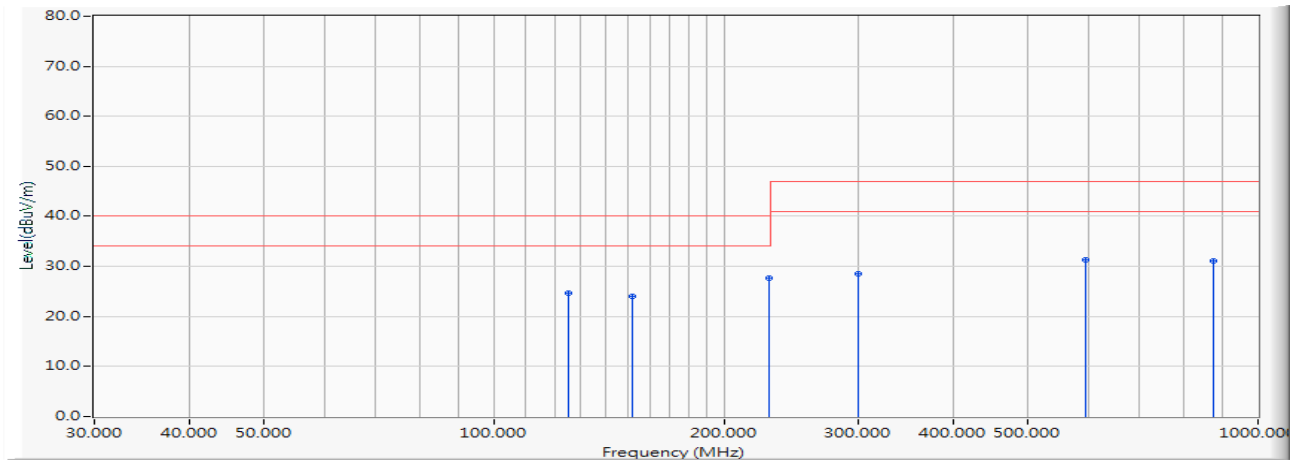

	Frequency (MHz)	Correct Factor (dB)	Reading Level (dBuV)	Measure Level (dBuV/m)	Margin (dB)	Limit (dBuV/m)	Detector Type
1	125.000	14.392	10.300	24.692	-15.308	40.000	QUASPEAK
2	151.630	12.828	11.100	23.928	-16.072	40.000	QUASPEAK
3	* 229.250	13.177	14.500	27.677	-12.323	40.000	QUASPEAK
4	300.000	16.907	11.600	28.507	-18.493	47.000	QUASPEAK
5	594.010	24.070	7.200	31.270	-15.730	47.000	QUASPEAK
6	875.000	27.560	3.500	31.060	-15.940	47.000	QUASPEAK

**Note:**

1. All Readings below 1GHz are Quasi-Peak, above are performed with peak and/or average measurements as necessary.
2. " \* ", means this data is the worst emission level.
3. Measurement Level = Reading Level + Correct Factor

Site: CB7	Time: 2016/02/03 - 19:50
Limit: VCCI_A_(Above_1G)	Margin: 0
Probe: CB7_Horn_9120D_1511	Polarity: Horizontal
EUT: Network Camera	Power: Power By PoE
Note: Mode 1	

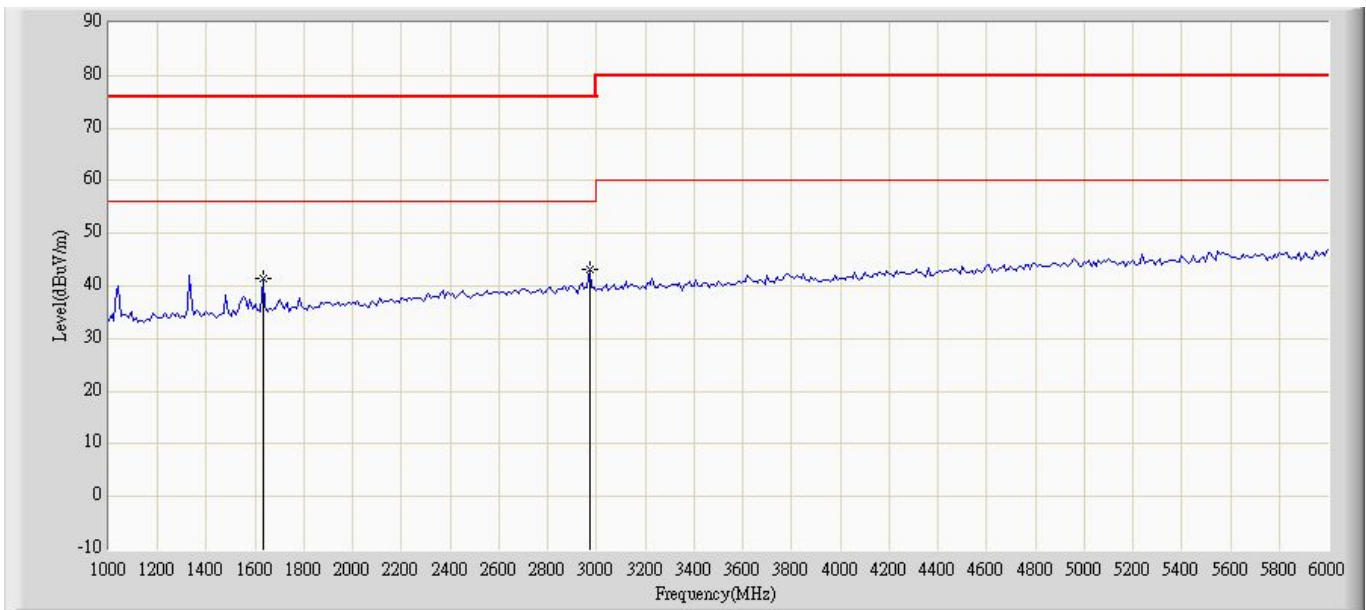

No	Flag	Mark	Frequency (MHz)	Measure Level (dBuV/m)	Reading Level (dBuV)	Over Limit (dB)	Limit (dBuV/m)	Factor	Type
1			1630.000	41.461	39.097	-34.539	76.000	2.364	PK
2		*	2970.000	43.225	37.199	-32.775	76.000	6.025	PK

**Note:**

1. All Readings below 1GHz are Quasi-Peak, above are performed with peak and/or average measurements as necessary.
2. " \* ", means this data is the worst emission level.
3. Measurement Level = Reading Level + Factor(Probe+Cable-Amp).

Site: CB7	Time: 2016/02/03 - 19:52
Limit: VCCI_A_(Above_1G)	Margin: 0
Probe: CB7_Horn_9120D_1511	Polarity: Vertical
EUT: Network Camera	Power: Power By PoE
Note: Mode 1	

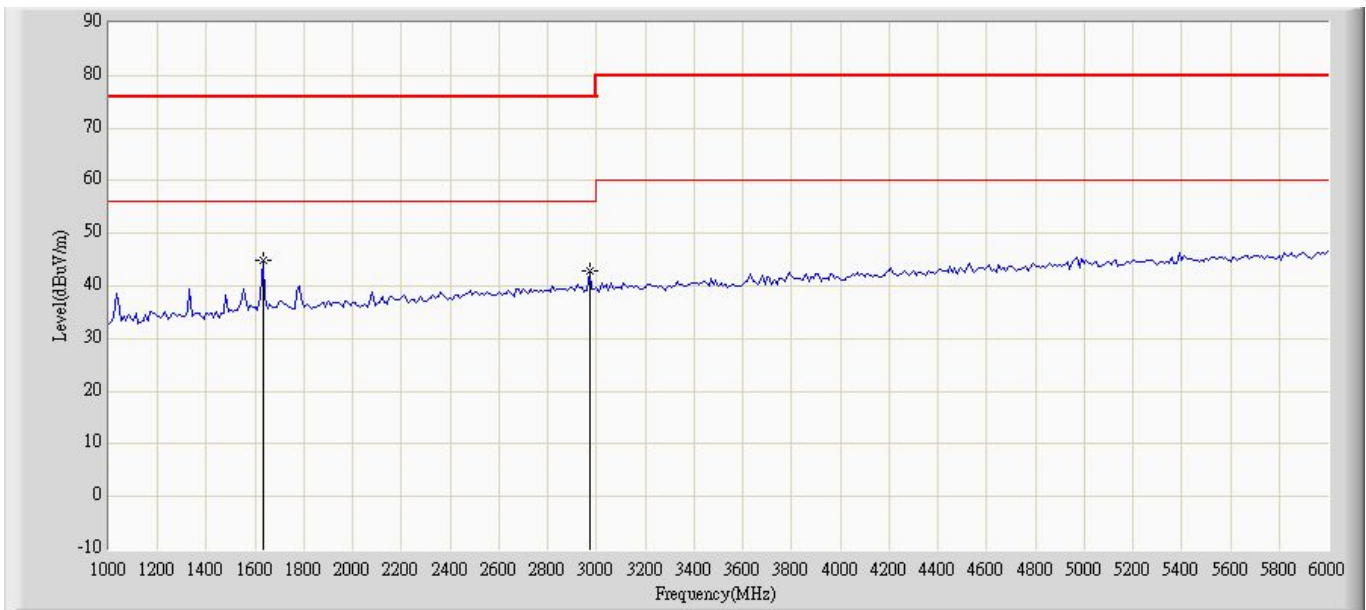

No	Flag	Mark	Frequency (MHz)	Measure Level (dBuV/m)	Reading Level (dBuV)	Over Limit (dB)	Limit (dBuV/m)	Factor	Type
1		*	1630.000	44.942	42.578	-31.058	76.000	2.364	PK
2			2970.000	43.008	36.982	-32.992	76.000	6.025	PK

**Note:**

1. All Readings below 1GHz are Quasi-Peak, above are performed with peak and/or average measurements as necessary.
2. " \* ", means this data is the worst emission level.
3. Measurement Level = Reading Level + Factor(Probe+Cable-Amp).

Site: CB7	Time: 2016/02/03 - 19:34
Limit: VCCI_A_(Above_1G)	Margin: 0
Probe: CB7_Horn_9120D_1511	Polarity: Horizontal
EUT: Network Camera	Power: AC 100V/50Hz
Note: Mode 2	

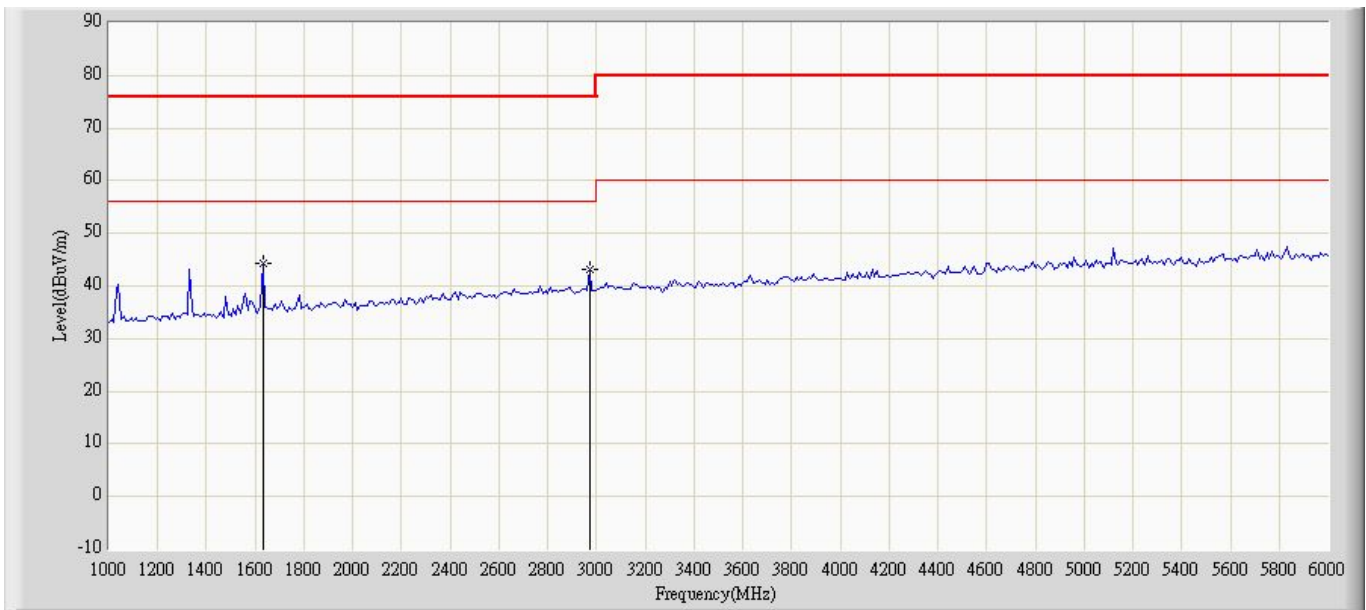

No	Flag	Mark	Frequency (MHz)	Measure Level (dBuV/m)	Reading Level (dBuV)	Over Limit (dB)	Limit (dBuV/m)	Factor	Type
1		*	1630.000	44.314	41.950	-31.686	76.000	2.364	PK
2			2970.000	43.218	37.192	-32.782	76.000	6.025	PK

**Note:**

1. All Readings below 1GHz are Quasi-Peak, above are performed with peak and/or average measurements as necessary.
2. " \* ", means this data is the worst emission level.
3. Measurement Level = Reading Level + Factor(Probe+Cable-Amp).

Site: CB7	Time: 2016/02/03 - 19:33
Limit: VCCI_A_(Above_1G)	Margin: 0
Probe: CB7_Horn_9120D_1511	Polarity: Vertical
EUT: Network Camera	Power: AC 100V/50Hz
Note: Mode 2	

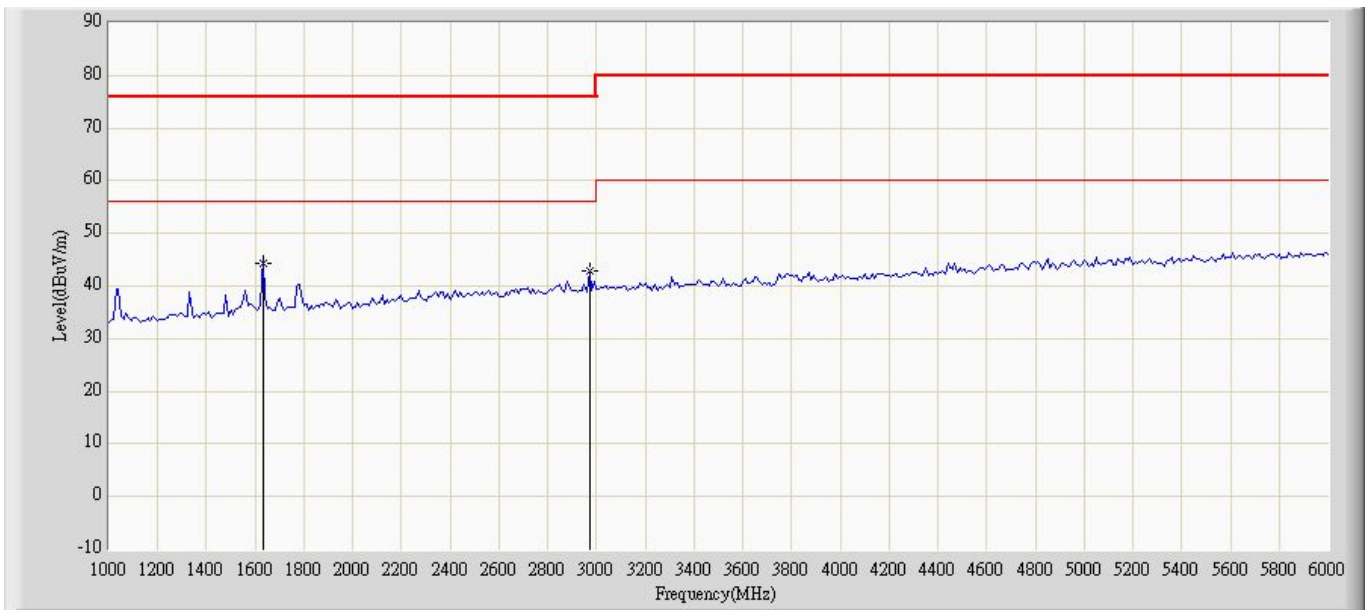

No	Flag	Mark	Frequency (MHz)	Measure Level (dBuV/m)	Reading Level (dBuV)	Over Limit (dB)	Limit (dBuV/m)	Factor	Type
1		*	1630.000	44.314	41.950	-31.686	76.000	2.364	PK
2			2970.000	42.858	36.832	-33.142	76.000	6.025	PK

**Note:**

1. All Readings below 1GHz are Quasi-Peak, above are performed with peak and/or average measurements as necessary.
2. " \* ", means this data is the worst emission level.
3. Measurement Level = Reading Level + Factor(Probe+Cable-Amp).

### 5.7. Test Photograph

Test Mode : Mode 1: IB9371-HT, Poe MODE

Description : Front View of Radiated Test



Test Mode : Mode 1: IB9371-HT, Poe MODE

Description : Back View of Radiated Test



Test Mode : Mode 1: IB9371-HT, Poe MODE

Description : Front View of High Frequency Radiated Test



Test Mode : Mode 2: IB9371-HT, DC MODE

Description : Front View of Radiated Test



Test Mode : Mode 2: IB9371-HT, DC MODE

Description : Back View of Radiated Test



Test Mode : Mode 2: IB9371-HT, DC MODE

Description : Front View of High Frequency Radiated Test



**6. Attachment**  
➤ **EUT Photograph**

(1) EUT Photo (M/N : IB9371-EHT)

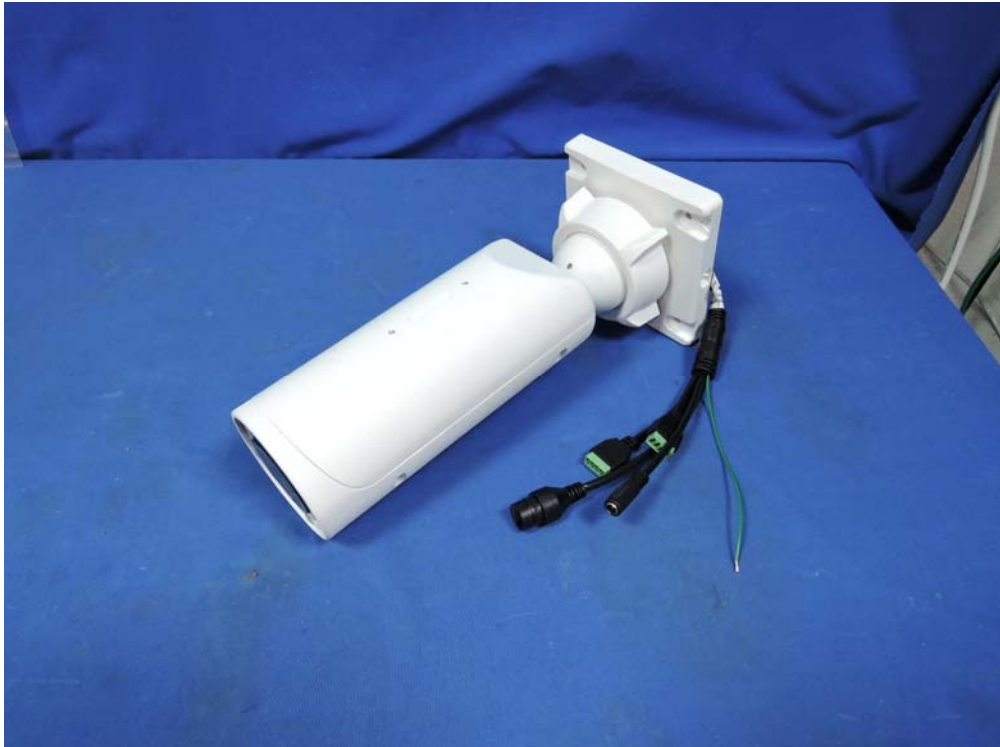

(2) EUT Photo (M/N : IB9371-EHT)



(3) EUT Photo (M/N : IB9371-EHT)

