



TEST REPORT
IEC 60950-1
Information technology equipment – Safety –
Part 1: General requirements

Report Number..... : SU0041-19003

Date of issue..... : 2019-07-15

Total number of pages : 50

Applicant's name : **VIVOTEK INC**

Address..... : 6TH FL, 192 LIEN CHENG RD CHUNG HO DISTRICT NEW
TAIPEI, 235 TAIWAN

Test specification:

Standard : IEC 60950-1:2005 (Second Edition) + Am 1:2009 + Am 2:2013

Test procedure : CB Scheme

Non-standard test method : N/A

Test Report Form No. : IEC60950_1F

Test Report Form(s) Originator : SGS Firmko Ltd

Master TRF : Dated 2014-02

Copyright © 2014 IEC System of Conformity Assessment Schemes for Electrotechnical Equipment and Components (IECEE System). All rights reserved.

This publication may be reproduced in whole or in part for non-commercial purposes as long as the IECEE is acknowledged as copyright owner and source of the material. IECEE takes no responsibility for and will not assume liability for damages resulting from the reader's interpretation of the reproduced material due to its placement and context.

If this Test Report Form is used by non-IECEE members, the IECEE/IEC logo and the reference to the CB Scheme procedure shall be removed.

This report is not valid as a CB Test Report unless signed by an approved CB Testing Laboratory and appended to a CB Test Certificate issued by an NCB in accordance with IECEE 02.

General disclaimer:

The test results presented in this report relate only to the object tested.

This report shall not be reproduced, except in full, without the written approval of the Issuing CB Testing Laboratory. The authenticity of this Test Report and its contents can be verified by contacting the NCB, responsible for this Test Report.

Test item description..... : Network Camera



Trade Mark..... : 

Manufacturer : **VIVOTEK INC**
6TH FL, 192 LIEN CHENG RD CHUNG HO DISTRICT NEW
TAIPEI, 235 TAIWAN

Model/Type reference : FD9187-HT, FD9187-H, FD9387-HTV, FD9387-HV, FD9387-
HVTM, FD9387-EHTV, FD9387-EHV

Ratings : 1) DC 42.5-57 V, 0.59-0.44 A (POE in) or DC 12 V, 1.9 A for
Model FD9387-EHTV, FD9387-EHV
2) DC 37-57 V, 0.31-0.20 A (POE in) or DC 12 V, 0.87 A for
Model FD9387-HTV, FD9387-HV, FD9387-HVTM, FD9187-

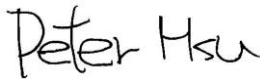
	HT, FD9187-H

Testing procedure and testing location:		
<input checked="" type="checkbox"/>	CB Testing Laboratory:	Sporton International Inc.
Testing location/ address.....:		14 Fl-2, No. 186, Jianyi Road Zhonghe District, New Taipei City CHINESE TAIPEI
<input type="checkbox"/>	Associated CB Testing Laboratory:	
Testing location/ address.....:		
Tested by (name + signature).....:		Peter Hsu/ Project handler 
Approved by (name + signature).....:		Hans Hsieh/ Reviewer 
<input type="checkbox"/>	Testing procedure: TMP/CTF Stage 1:	
Testing location/ address.....:		
Tested by (name + signature).....:		
Approved by (name + signature).....:		
<input type="checkbox"/>	Testing procedure: WMT/CTF Stage 2:	
Testing location/ address.....:		
Tested by (name + signature).....:		
Witnessed by (name + signature).....:		
Approved by (name + signature).....:		
<input type="checkbox"/>	Testing procedure: SMT/CTF Stage 3 or 4:	
Testing location/ address.....:		
Tested by (name + signature).....:		
Witnessed by (name + signature).....:		
Approved by (name + signature).....:		
Supervised by (name + signature).....:		

List of Attachments (including a total number of pages in each attachment):		
Attachment No.	Description	Page(s)
1	National Differences	76
2	Photograph	48
3	Diagrams	05
4	Miscellaneous	57
4-01	Miscellaneous (IEC60950-22 Test report)	02-25
4-02	Miscellaneous (IR LED IEC62471 test report)	26-50
4-03	Miscellaneous (IP66 Test report)	51-57
Summary of testing:		
Tests performed (name of test and test clause): <ul style="list-style-type: none"> - Input: Single-Phase (1.6.2) - Durability of Marking (1.7.11) - Limited Current Circuit Measurement (2.4) - Limited Power Source Measurements (2.5) - Steady Force Test (4.2.4) - Impact Test (4.2.5) - Stress Relief Test (4.2.7) - Loading / Ceiling mounting Tests (4.2.10) - Heating (4.5.1, 1.4.12, 1.4.13) - Component Failure Test (5.3) 		Testing location: Sporton International Inc. / 14 Fl-2, No. 186, Jianyi Road Zhonghe District, New Taipei City CHINESE TAIPEI
Summary of compliance with National Differences: List of countries addressed EU Group According to CB Bulletin, the National Differences include Australia (AU), Canada (CA), China (CN), Germany (DE), Israel (IL), Japan (JP), Korea (KR), Switzerland (CH) and United States of America (US). Group Differences (CENELEC COMMON MODIFICATIONS) as listed in the European Standard are recorded in this Report. <input checked="" type="checkbox"/> The product fulfils the requirements of <u>EN 60950-1:2006+A11:2009+A1:2010+A12:2011+A2: 2013.</u>		

Copy of marking plate:

The artwork below may be only a draft. The use of certification marks on a product must be authorized by the respective NCBs that own these marks.





FD9387-HV
Network Camera

VIVOTEK

MAC:0002D1XXXXXX



12V --- 0.87A
PoE 37-57V --- 0.31-0.20A

 
 
IP66
RoHS

This device complies with Part 15 of the FCC Rules. Operation is subject to the following two conditions:
(1) this device may not cause harmful interference, and
(2) this device must accept any interference received, including interference that may cause undesired operation.
6F, No.192, Lien-Cheng Rd., Chung-Ho, New Taipei City, 235, Taiwan, R.O.C.
Pat.6, 930, 709 www.vivotek.com Made in Taiwan





FD9387-EHV
Network Camera

VIVOTEK

MAC:0002D1XXXXXX



12V --- 1.9A
PoE 42.5-57V --- 0.59-0.44A

 
 
IP66
RoHS

This device complies with Part 15 of the FCC Rules. Operation is subject to the following two conditions:
(1) this device may not cause harmful interference, and
(2) this device must accept any interference received, including interference that may cause undesired operation.
6F, No.192, Lien-Cheng Rd., Chung-Ho, New Taipei City, 235, Taiwan, R.O.C.
Pat.6, 930, 709 www.vivotek.com Made in Taiwan

FD9387-HVTPM
Network Camera 

MAC:0002D1XXXXXX

12V ---0.87A
PoE 37-57V ---0.31-0.20A

 
 
IP66
RoHS

This device complies with Part 15 of the FCC Rules. Operation is subject to the following two conditions:
(1) this device may not cause harmful interference, and
(2) this device must accept any interference received, including interference that may cause undesired operation.

6F, No.192, Lien-Cheng Rd., Chung-Ho, New Taipei City, 235, Taiwan, R.O.C.
Pat.6, 930, 709 www.vivotek.com Made in Taiwan

FD9387-HTV
Network Camera 

MAC:0002D1XXXXXX



12V ---0.87A
PoE 37-57V ---0.31-0.20A

 
 
IP66
RoHS





This device complies with Part 15 of the FCC Rules. Operation is subject to the following two conditions:
(1) this device may not cause harmful interference, and
(2) this device must accept any interference received, including interference that may cause undesired operation.

6F, No.192, Lien-Cheng Rd., Chung-Ho, New Taipei City, 235, Taiwan, R.O.C.
Pat.6, 930, 709 www.vivotek.com Made in Taiwan

FD9387-EHTV
Network Camera 

MAC:0002D1XXXXXX

12V ---1.9A
PoE 42.5-57V ---0.59-0.44A

 
 
IP66
RoHS

This device complies with Part 15 of the FCC Rules. Operation is subject to the following two conditions:
(1) this device may not cause harmful interference, and
(2) this device must accept any interference received, including interference that may cause undesired operation.



6F, No.192, Lien-Cheng Rd., Chung-Ho, New Taipei City, 235, Taiwan, R.O.C.
Pat.6, 930, 709 www.vivotek.com Made in Taiwan

Test item particulars.....:	
Equipment mobility.....:	<input type="checkbox"/> movable <input type="checkbox"/> hand-held <input type="checkbox"/> transportable <input checked="" type="checkbox"/> stationary <input type="checkbox"/> for building-in <input type="checkbox"/> direct plug-in
Connection to the mains.....:	<input type="checkbox"/> pluggable equipment <input type="checkbox"/> type A <input type="checkbox"/> type B <input type="checkbox"/> permanent connection <input type="checkbox"/> detachable power supply cord <input type="checkbox"/> non-detachable power supply cord <input checked="" type="checkbox"/> not directly connected to the mains
Operating condition.....:	<input checked="" type="checkbox"/> continuous <input type="checkbox"/> rated operating / resting time:
Access location	<input checked="" type="checkbox"/> operator accessible <input type="checkbox"/> restricted access location
Over voltage category (OVC)	<input type="checkbox"/> OVC I <input type="checkbox"/> OVC II <input type="checkbox"/> OVC III <input type="checkbox"/> OVC IV <input checked="" type="checkbox"/> other: N/A
Mains supply tolerance (%) or absolute mains supply values	N/A
Tested for IT power systems	<input type="checkbox"/> Yes <input checked="" type="checkbox"/> No
IT testing, phase-phase voltage (V)	N/A
Class of equipment	<input type="checkbox"/> Class I <input type="checkbox"/> Class II <input checked="" type="checkbox"/> Class III <input type="checkbox"/> Not classified
Considered current rating of protective device as part of the building installation (A)	N/A
Pollution degree (PD)	<input type="checkbox"/> PD 1 <input checked="" type="checkbox"/> PD 2 <input type="checkbox"/> PD 3
IP protection class	IP66
Altitude during operation (m)	Up to 2000m
Altitude of test laboratory (m)	Not over 2000m
Mass of equipment (kg)	0.908 Max.

Possible test case verdicts:	
- test case does not apply to the test object.....:	N/A
- test object does meet the requirement.....:	P (Pass)
- test object does not meet the requirement.....:	F (Fail)
Testing.....:	
Date of receipt of test item	2019-03-22
Date (s) of performance of tests	2019-03-23 to 2019-05-01
General remarks:	
"(See Enclosure #)" refers to additional information appended to the report. "(See appended table)" refers to a table appended to the report.	
Throughout this report a <input type="checkbox"/> comma / <input checked="" type="checkbox"/> point is used as the decimal separator.	

Manufacturer's Declaration per sub-clause 4.2.5 of IEC60950-1:						
The application for obtaining a CB Test Certificate includes more than one factory location and a declaration from the Manufacturer stating that the sample(s) submitted for evaluation is (are) representative of the products from each factory has been provided				<input type="checkbox"/> Yes <input checked="" type="checkbox"/> Not applicable		
When differences exist; they shall be identified in the General product information section.						
Name and address of factory (ies) : VIVOTEK INC 5TH FL, 168 LIEN CHENG RD CHUNG HO DISTRICT NEW TAIPEI, 235 TAIWAN						
General product information:						
-The equipment is a Network Camera, intended for used with information technology equipment.						
-The unit is supplied by External Adaptor or POE device which compliance with Limited Power Source (Sub-clause 2.5).						
-This equipment is to be connected to PoE networks or external ac adaptor without routing to the outdoors						
-The test sample was a pre-production sample without serial number.						
-The equipment was investigated to the following additional standards: (1) IEC60950-22 - Equipment to be Installed Outdoors, (2) IEC 60529-Degrees of protection provided by enclosures (IP Code)						
- Unless otherwise indicated, all tests were conducted on Model FD9387-EHTV, FD9387-HTV, FD9187-HT						
Model difference						
Model	FD9387-EHTV	FD9387-EHV	FD9387-HTV	FD9387-HV, FD9387-HVTPM	FD9187-HT	FD9187-H
Rating	DC 42.5-57 V, 0.59-0.44 A or DC 12V, 1.9A		DC 37-57 V , 0.31-0.20 A or DC 12V, 0.87A			
Heater	Yes		No		No	
Enclosure	Metal (Outdoor)		Metal (Outdoor)		Plastic (Indoor)	
Lens	Remote	Fix	Remote	Fix	Remote	Fix
Ambient	-50°C ~55°C		-30°C ~55°C		-10°C ~50°C	
LED board	Remote board	Fix board	Remote board	Fix board	Remote board	Fix board
Abbreviations used in the report:						
- normal conditions	N.C.	- single fault conditions	S.F.C			
- functional insulation	OP	- basic insulation	BI			
- double insulation	DI	- supplementary insulation	SI			
- between parts of opposite polarity	BOP	- reinforced insulation	RI			
Indicate used abbreviations (if any)						

IEC 60950-1			
Clause	Requirement + Test	Result - Remark	Verdict
1	GENERAL		P
1.5	Components		P
1.5.1	General		P
	Comply with IEC 60950-1 or relevant component standard	(See appended table 1.5.1).	P
1.5.2	Evaluation and testing of components	Components certified to IEC harmonized standard and checked for correct application. Components, for which no relevant IEC-Standard existed, have been tested under the conditions occurring in the equipment, using applicable parts of IEC 60950-1. Components not certified are used in accordance with their ratings and they comply with applicable parts of IEC 60950-1 and the relevant component Standard.	P
1.5.3	Thermal controls		N/A
1.5.4	Transformers		N/A
1.5.5	Interconnecting cables		N/A
1.5.6	Capacitors bridging insulation		N/A
1.5.7	Resistors bridging insulation		N/A
1.5.7.1	Resistors bridging functional, basic or supplementary insulation		N/A
1.5.7.2	Resistors bridging double or reinforced insulation between a.c. mains and other circuits		N/A
1.5.7.3	Resistors bridging double or reinforced insulation between a.c. mains and antenna or coaxial cable		N/A
1.5.8	Components in equipment for IT power systems		N/A
1.5.9	Surge suppressors		N/A
1.5.9.1	General		N/A
1.5.9.2	Protection of VDRs		N/A
1.5.9.3	Bridging of functional insulation by a VDR		N/A
1.5.9.4	Bridging of basic insulation by a VDR		N/A
1.5.9.5	Bridging of supplementary, double or reinforced insulation by a VDR		N/A

IEC 60950-1			
Clause	Requirement + Test	Result - Remark	Verdict
1.6	Power interface		P
1.6.1	AC power distribution systems		N/A
1.6.2	Input current	The steady state input current of the equipment did not exceed the RATED CURRENT by more than 10% under NORMAL LOAD. (See appended table 1.6.2).	P
1.6.3	Voltage limit of hand-held equipment		N/A
1.6.4	Neutral conductor		N/A
1.7	Marking and instructions		P
1.7.1	Power rating and identification markings	See below.	P
1.7.1.1	Power rating marking	See below.	P
	Multiple mains supply connections.....:		N/A
	Rated voltage(s) or voltage range(s) (V)	1) DC 42.5-57 V or DC 12 V, for Model FD9387-EHTV, FD9387-EHV 2) DC 37-57 V or DC 12 V, for Model FD9387-HTV, FD9387-HV, FD9387-HVTPM, FD9187-HT, FD9187-H	P
	Symbol for nature of supply, for d.c. only.....:	IEC 60417, No. 5031: 	P
	Rated frequency or rated frequency range (Hz) ...:		N/A
	Rated current (mA or A)	1) 0.59-0.44 A or 1.9 A for Model FD9387-EHTV, FD9387-EHV 2) 0.31-0.20 A or 0.87 A for Model FD9387-HTV, FD9387-HV, FD9387-HVTPM, FD9187-HT, FD9187-H	P
1.7.1.2	Identification markings	See below.	P
	Manufacturer's name or trade-mark or identification mark		P
	Model identification or type reference	FD9187-HT, FD9187-H, FD9387-HTV, FD9387-HV, FD9387-HVTPM, FD9387-EHTV, FD9387-EHV	P

IEC 60950-1			
Clause	Requirement + Test	Result - Remark	Verdict
	Symbol for Class II equipment only		N/A
	Other markings and symbols	Additional symbols or marking do not give rise to misunderstandings. See Copy of marking plate.	P
1.7.1.3	Use of graphical symbols		N/A
1.7.2	Safety instructions and marking	See below.	P
1.7.2.1	General	Safety instructions in English. Other languages will be provided when submitted for national approval.	P
1.7.2.2	Disconnect devices		N/A
1.7.2.3	Overcurrent protective device		N/A
1.7.2.4	IT power distribution systems		N/A
1.7.2.5	Operator access with a tool		N/A
1.7.2.6	Ozone		N/A
1.7.3	Short duty cycles		N/A
1.7.4	Supply voltage adjustment		N/A
	Methods and means of adjustment; reference to installation instructions		N/A
1.7.5	Power outlets on the equipment		N/A
1.7.6	Fuse identification (marking, special fusing characteristics, cross-reference)		N/A
1.7.7	Wiring terminals		N/A
1.7.7.1	Protective earthing and bonding terminals		N/A
1.7.7.2	Terminals for a.c. mains supply conductors		N/A
1.7.7.3	Terminals for d.c. mains supply conductors		N/A
1.7.8	Controls and indicators	See below.	P
1.7.8.1	Identification, location and marking		N/A
1.7.8.2	Colours	Only functional indicators use colour.	P
1.7.8.3	Symbols according to IEC 60417.....		N/A
1.7.8.4	Markings using figures		N/A
1.7.9	Isolation of multiple power sources		N/A
1.7.10	Thermostats and other regulating devices		N/A

IEC 60950-1			
Clause	Requirement + Test	Result - Remark	Verdict
1.7.11	Durability	The marking is durable and legible. After test, the marking has no curling and is not able to be removed easily and withstood the required test.	P
1.7.12	Removable parts	No any markings provided on removable parts.	N/A
1.7.13	Replaceable batteries		N/A
	Language(s)		—
1.7.14	Equipment for restricted access locations		N/A

2	PROTECTION FROM HAZARDS		P
2.1	Protection from electric shock and energy hazards		P
2.1.1	Protection in operator access areas	See below.	P
2.1.1.1	Access to energized parts	Outdoor model: No access with test finger and test pin to any parts with only basic insulation to secondary hazardous voltage. Any hazardous parts accessible are unlikely. Indoor model: Only with SELV circuit, no electric shock or energy hazard inside the unit.	P
	Test by inspection	Complied.	P
	Test with test finger (Figure 2A)	Complied.	P
	Test with test pin (Figure 2B)	Complied.	P
	Test with test probe (Figure 2C)		N/A
2.1.1.2	Battery compartments		N/A
2.1.1.3	Access to ELV wiring		N/A
	Working voltage (V_{peak} or V_{rms}); minimum distance through insulation (mm)		—
2.1.1.4	Access to hazardous voltage circuit wiring		N/A
2.1.1.5	Energy hazards	No energy hazardous in operator access area.	N/A
2.1.1.6	Manual controls		N/A
2.1.1.7	Discharge of capacitors in equipment		N/A
	Measured voltage (V); time-constant (s).....		—

IEC 60950-1			
Clause	Requirement + Test	Result - Remark	Verdict
2.1.1.8	Energy hazards – d.c. mains supply		N/A
	a) Capacitor connected to the d.c. mains supply .. :		N/A
	b) Internal battery connected to the d.c. mains supply :		N/A
2.1.1.9	Audio amplifiers		N/A
2.1.2	Protection in service access areas		N/A
2.1.3	Protection in restricted access locations		N/A

2.2	SELV circuits		P
2.2.1	General requirements	<p>Outdoor model: Can only touch the metal enclosure, any hazardous parts accessible are unlikely.</p> <p>Indoor model: Within SELV circuits.</p>	P
2.2.2	Voltages under normal conditions (V)	<p>Outdoor model: See Clause 2.4. L.C.C test.</p> <p>Indoor model: Within SELV circuits.</p>	P
2.2.3	Voltages under fault conditions (V)	<p>Outdoor model: The worst case fault was when Input shorted with metal enclosure. Therefore, performed sub-clause 2.4 L.C.C test of this report to replace SELV required.</p> <p>Indoor model: Within SELV circuits.</p>	P
2.2.4	Connection of SELV circuits to other circuits		P

2.3	TNV circuits		N/A
2.3.1	Limits	No TNV circuits.	N/A
	Type of TNV circuits		—
2.3.2	Separation from other circuits and from accessible parts		N/A
2.3.2.1	General requirements		N/A
2.3.2.2	Protection by basic insulation		N/A
2.3.2.3	Protection by earthing		N/A
2.3.2.4	Protection by other constructions		N/A
2.3.3	Separation from hazardous voltages		N/A

IEC 60950-1			
Clause	Requirement + Test	Result - Remark	Verdict
	Insulation employed		—
2.3.4	Connection of TNV circuits to other circuits		N/A
	Insulation employed		—
2.3.5	Test for operating voltages generated externally		N/A

2.4	Limited current circuits		P
2.4.1	General requirements	The Limit of subclause 2.4.2 were not exceeded.	P
2.4.2	Limit values	See below.	P
	Frequency (Hz)	See below.	—
	Measured current (mA)	User accessible area: Metal enclosure to Earth 1) 0.058 mA for DC 57 V Input (Normal) Frequency: 0.06 kHz limit current: 0.7 mA 2) 0.068 mA for DC 57 V Input (T1 Pin 1 to metal enclosure short) Frequency: 0.06 kHz limit current: 0.7 mA 3) 0.053 mA for DC 57 V Input (T1 Pin 10 to metal enclosure short) Frequency: 0.06 kHz limit current: 0.7 mA 4) 0.053 mA for DC 57 V Input (T1 Pin 11 to metal enclosure short) Frequency: 0.06 kHz limit current: 0.7 mA	—
	Measured voltage (V)	User accessible area: Metal enclosure to Earth 1) 0.116 Vpk max. for DC 57 V Input (Normal) 2) 0.136 Vpk for DC 57 V Input (T1 Pin 1 to metal enclosure short) 3) 0.106 Vpk for AC 24 V Input (T1 Pin 10 to metal enclosure short) 4) 1.06 Vpk for AC 24 V Input (T1 Pin 11 to metal enclosure short)	—
	Measured circuit capacitance (nF or μ F)		—

IEC 60950-1			
Clause	Requirement + Test	Result - Remark	Verdict
2.4.3	Connection of limited current circuits to other circuits	The Limit of subclause 2.4.2 were not exceeded.	P

2.5	Limited power sources		P
	a) Inherently limited output	LAN port, Terminal Connector.	P
	b) Impedance limited output		N/A
	c) Regulating network or IC current limiter, limits output under normal operating and single fault condition		N/A
	Use of integrated circuit (IC) current limiters		N/A
	d) Overcurrent protective device limited output		N/A
	Max. output voltage (V), max. output current (A), max. apparent power (VA)	(See appended table 2.5.)	—
	Current rating of overcurrent protective device (A) ..		—

2.6	Provisions for earthing and bonding		N/A
2.6.1	Protective earthing	Class III equipment.	N/A
2.6.2	Functional earthing		N/A
	Use of symbol for functional earthing		N/A
2.6.3	Protective earthing and protective bonding conductors		N/A
2.6.3.1	General		N/A
2.6.3.2	Size of protective earthing conductors		N/A
	Rated current (A), cross-sectional area (mm ²), AWG		—
2.6.3.3	Size of protective bonding conductors		N/A
	Rated current (A), cross-sectional area (mm ²), AWG		—
	Protective current rating (A), cross-sectional area (mm ²), AWG		
2.6.3.4	Resistance of earthing conductors and their terminations; resistance (Ω), voltage drop (V), test current (A), duration (min)		N/A
2.6.3.5	Colour of insulation		N/A
2.6.4	Terminals		N/A
2.6.4.1	General		N/A
2.6.4.2	Protective earthing and bonding terminals		N/A
	Rated current (A), type, nominal thread diameter (mm)		—

IEC 60950-1			
Clause	Requirement + Test	Result - Remark	Verdict
2.6.4.3	Separation of the protective earthing conductor from protective bonding conductors		N/A
2.6.5	Integrity of protective earthing		N/A
2.6.5.1	Interconnection of equipment		N/A
2.6.5.2	Components in protective earthing conductors and protective bonding conductors		N/A
2.6.5.3	Disconnection of protective earth		N/A
2.6.5.4	Parts that can be removed by an operator		N/A
2.6.5.5	Parts removed during servicing		N/A
2.6.5.6	Corrosion resistance		N/A
2.6.5.7	Screws for protective bonding		N/A
2.6.5.8	Reliance on telecommunication network or cable distribution system		N/A

2.7	Overcurrent and earth fault protection in primary circuits		N/A
2.7.1	Basic requirements		N/A
	Instructions when protection relies on building installation		N/A
2.7.2	Faults not simulated in 5.3.7		N/A
2.7.3	Short-circuit backup protection		N/A
2.7.4	Number and location of protective devices		N/A
2.7.5	Protection by several devices		N/A
2.7.6	Warning to service personnel.....		N/A

2.8	Safety interlocks		N/A
2.8.1	General principles	No safety interlocks.	N/A
2.8.2	Protection requirements		N/A
2.8.3	Inadvertent reactivation		N/A
2.8.4	Fail-safe operation		N/A
	Protection against extreme hazard		N/A
2.8.5	Moving parts		N/A
2.8.6	Overriding		N/A
2.8.7	Switches, relays and their related circuits		N/A
2.8.7.1	Separation distances for contact gaps and their related circuits (mm)		N/A
2.8.7.2	Overload test		N/A
2.8.7.3	Endurance test		N/A

IEC 60950-1			
Clause	Requirement + Test	Result - Remark	Verdict
2.8.7.4	Electric strength test		N/A
2.8.8	Mechanical actuators		N/A

2.9	Electrical insulation		P
2.9.1	Properties of insulating materials	Functional Insulation only. See Sub-Clause 5.3.4.	P
2.9.2	Humidity conditioning		N/A
	Relative humidity (%), temperature (°C)		—
2.9.3	Grade of insulation	See Sub-Clause 2.9.1.	P
2.9.4	Separation from hazardous voltages		N/A
	Method(s) used		—

2.10	Clearances, creepage distances and distances through insulation		P
2.10.1	General	Functional Insulation only. See Sub-Clause 5.3.4.	P
2.10.1.1	Frequency		N/A
2.10.1.2	Pollution degrees		N/A
2.10.1.3	Reduced values for functional insulation		N/A
2.10.1.4	Intervening unconnected conductive parts		N/A
2.10.1.5	Insulation with varying dimensions		N/A
2.10.1.6	Special separation requirements		N/A
2.10.1.7	Insulation in circuits generating starting pulses		N/A
2.10.2	Determination of working voltage		N/A
2.10.2.1	General		N/A
2.10.2.2	RMS working voltage		N/A
2.10.2.3	Peak working voltage		N/A
2.10.3	Clearances		N/A
2.10.3.1	General		N/A
2.10.3.2	Mains transient voltages		N/A
	a) AC mains supply		N/A
	b) Earthed d.c. mains supplies		N/A
	c) Unearthed d.c. mains supplies		N/A
	d) Battery operation		N/A
2.10.3.3	Clearances in primary circuits		N/A
2.10.3.4	Clearances in secondary circuits		N/A

IEC 60950-1			
Clause	Requirement + Test	Result - Remark	Verdict
2.10.3.5	Clearances in circuits having starting pulses		N/A
2.10.3.6	Transients from a.c. mains supply		N/A
2.10.3.7	Transients from d.c. mains supply		N/A
2.10.3.8	Transients from telecommunication networks and cable distribution systems		N/A
2.10.3.9	Measurement of transient voltage levels		N/A
	a) Transients from a mains supply		N/A
	For an a.c. mains supply		N/A
	For a d.c. mains supply		N/A
	b) Transients from a telecommunication network :		N/A
2.10.4	Creepage distances		N/A
2.10.4.1	General		N/A
2.10.4.2	Material group and comparative tracking index		N/A
	CTI tests		—
2.10.4.3	Minimum creepage distances		N/A
2.10.5	Solid insulation		N/A
2.10.5.1	General		N/A
2.10.5.2	Distances through insulation		N/A
2.10.5.3	Insulating compound as solid insulation		N/A
2.10.5.4	Semiconductor devices		N/A
2.10.5.5.	Cemented joints		N/A
2.10.5.6	Thin sheet material – General		N/A
2.10.5.7	Separable thin sheet material		N/A
	Number of layers (pcs)		—
2.10.5.8	Non-separable thin sheet material		N/A
2.10.5.9	Thin sheet material – standard test procedure		N/A
	Electric strength test		—
2.10.5.10	Thin sheet material – alternative test procedure		N/A
	Electric strength test		—
2.10.5.11	Insulation in wound components		N/A
2.10.5.12	Wire in wound components		N/A
	Working voltage		N/A
	a) Basic insulation not under stress		N/A
	b) Basic, supplementary, reinforced insulation		N/A
	c) Compliance with Annex U		N/A

IEC 60950-1			
Clause	Requirement + Test	Result - Remark	Verdict
	Two wires in contact inside wound component; angle between 45° and 90°		N/A
2.10.5.13	Wire with solvent-based enamel in wound components		N/A
	Electric strength test		—
	Routine test		N/A
2.10.5.14	Additional insulation in wound components		N/A
	Working voltage		N/A
	- Basic insulation not under stress		N/A
	- Supplementary, reinforced insulation		N/A
2.10.6	Construction of printed boards		N/A
2.10.6.1	Uncoated printed boards		N/A
2.10.6.2	Coated printed boards		N/A
2.10.6.3	Insulation between conductors on the same inner surface of a printed board		N/A
2.10.6.4	Insulation between conductors on different layers of a printed board		N/A
	Distance through insulation		N/A
	Number of insulation layers (pcs)		N/A
2.10.7	Component external terminations		N/A
2.10.8	Tests on coated printed boards and coated components		N/A
2.10.8.1	Sample preparation and preliminary inspection		N/A
2.10.8.2	Thermal conditioning		N/A
2.10.8.3	Electric strength test		N/A
2.10.8.4	Abrasion resistance test		N/A
2.10.9	Thermal cycling		N/A
2.10.10	Test for Pollution Degree 1 environment and insulating compound		N/A
2.10.11	Tests for semiconductor devices and cemented joints		N/A
2.10.12	Enclosed and sealed parts		N/A
3	WIRING, CONNECTIONS AND SUPPLY		P
3.1	General		P

IEC 60950-1			
Clause	Requirement + Test	Result - Remark	Verdict
3.1.1	Current rating and overcurrent protection	All wires/conductors possess adequate cross-sectional areas for their intended application and internal wiring are adequately insulated.	P
3.1.2	Protection against mechanical damage	The wires are routed away from sharp edges and parts which could damage insulation.	P
3.1.3	Securing of internal wiring	The wires are positioned in such a manner that prevents excessive strain, loosening of terminal connections and damage of conductor insulation.	P
3.1.4	Insulation of conductors		N/A
3.1.5	Beads and ceramic insulators		N/A
3.1.6	Screws for electrical contact pressure		N/A
3.1.7	Insulating materials in electrical connections		N/A
3.1.8	Self-tapping and spaced thread screws		N/A
3.1.9	Termination of conductors		N/A
	10 N pull test		N/A
3.1.10	Sleeving on wiring		N/A

3.2	Connection to a mains supply		N/A
3.2.1	Means of connection		N/A
3.2.1.1	Connection to an a.c. mains supply		N/A
3.2.1.2	Connection to a d.c. mains supply		N/A
3.2.2	Multiple supply connections		N/A
3.2.3	Permanently connected equipment		N/A
	Number of conductors, diameter of cable and conduits (mm)		—
3.2.4	Appliance inlets		N/A
3.2.5	Power supply cords		N/A
3.2.5.1	AC power supply cords		N/A
	Type		—
	Rated current (A), cross-sectional area (mm ²), AWG		—
3.2.5.2	DC power supply cords		N/A
3.2.6	Cord anchorages and strain relief		N/A

IEC 60950-1			
Clause	Requirement + Test	Result - Remark	Verdict
	Mass of equipment (kg), pull (N)		—
	Longitudinal displacement (mm)		—
3.2.7	Protection against mechanical damage		N/A
3.2.8	Cord guards		N/A
	Diameter or minor dimension D (mm); test mass (g)		—
	Radius of curvature of cord (mm)		—
3.2.9	Supply wiring space		N/A

3.3	Wiring terminals for connection of external conductors		N/A
3.3.1	Wiring terminals	No wiring terminals.	N/A
3.3.2	Connection of non-detachable power supply cords		N/A
3.3.3	Screw terminals		N/A
3.3.4	Conductor sizes to be connected		N/A
	Rated current (A), cord/cable type, cross-sectional area (mm ²)		—
3.3.5	Wiring terminal sizes		N/A
	Rated current (A), type, nominal thread diameter (mm)		—
3.3.6	Wiring terminal design		N/A
3.3.7	Grouping of wiring terminals		N/A
3.3.8	Stranded wire		N/A

3.4	Disconnection from the mains supply		N/A
3.4.1	General requirement	No connection to mains supply.	N/A
3.4.2	Disconnect devices		N/A
3.4.3	Permanently connected equipment		N/A
3.4.4	Parts which remain energized		N/A
3.4.5	Switches in flexible cords		N/A
3.4.6	Number of poles - single-phase and d.c. equipment		N/A
3.4.7	Number of poles - three-phase equipment		N/A
3.4.8	Switches as disconnect devices		N/A
3.4.9	Plugs as disconnect devices		N/A
3.4.10	Interconnected equipment		N/A
3.4.11	Multiple power sources		N/A

IEC 60950-1			
Clause	Requirement + Test	Result - Remark	Verdict
3.5	Interconnection of equipment		P
3.5.1	General requirements	See below.	P
3.5.2	Types of interconnection circuits	Interconnection circuits are SELV CIRCUITS.	P
3.5.3	ELV circuits as interconnection circuits		N/A
3.5.4	Data ports for additional equipment	(See appended table 2.5.)	P
4	PHYSICAL REQUIREMENTS		P
4.1	Stability		N/A
	Angle of 10°		N/A
	Test force (N)		N/A
4.2	Mechanical strength		P
4.2.1	General	See below.	P
	Rack-mounted equipment.		N/A
4.2.2	Steady force test, 10 N		N/A
4.2.3	Steady force test, 30 N		N/A
4.2.4	Steady force test, 250 N	250 N were applied to the outer enclosure. After subjected 250 N, no energy or other hazards.	P
4.2.5	Impact test	See below.	P
	Fall test	No hazards after steel sphere ball impact test.	P
	Swing test		N/A
4.2.6	Drop test; height (mm)		N/A
4.2.7	Stress relief test	Considered of Lens cover, after 7 h at 86 °C and cooling down to room temperature, no shrinkage, distortion or loosing of enclosure parts.	P
4.2.8	Cathode ray tubes		N/A
	Picture tube separately certified		N/A
4.2.9	High pressure lamps		N/A
4.2.10	Wall or ceiling mounted equipment; force (N)	Complied, 50N.	P
4.3	Design and construction		P

IEC 60950-1			
Clause	Requirement + Test	Result - Remark	Verdict
4.3.1	Edges and corners	All edges and corners are judged to be sufficiently well rounded and smoothed so as not to constitute a hazard.	P
4.3.2	Handles and manual controls; force (N)		N/A
4.3.3	Adjustable controls		N/A
4.3.4	Securing of parts		N/A
4.3.5	Connection by plugs and sockets		N/A
4.3.6	Direct plug-in equipment		N/A
	Torque		—
	Compliance with the relevant mains plug standard		N/A
4.3.7	Heating elements in earthed equipment		N/A
4.3.8	Batteries		N/A
	- Overcharging of a rechargeable battery		N/A
	- Unintentional charging of a non-rechargeable battery		N/A
	- Reverse charging of a rechargeable battery		N/A
	- Excessive discharging rate for any battery		N/A
4.3.9	Oil and grease		N/A
4.3.10	Dust, powders, liquids and gases		N/A
4.3.11	Containers for liquids or gases		N/A
4.3.12	Flammable liquids		N/A
	Quantity of liquid (l)		N/A
	Flash point (°C)		N/A
4.3.13	Radiation	See below.	P
4.3.13.1	General	See below.	P
4.3.13.2	Ionizing radiation		N/A
	Measured radiation (pA/kg)		—
	Measured high-voltage (kV)		—
	Measured focus voltage (kV)		—
	CRT markings		—
4.3.13.3	Effect of ultraviolet (UV) radiation on materials		N/A
	Part, property, retention after test, flammability classification		N/A
4.3.13.4	Human exposure to ultraviolet (UV) radiation		N/A
4.3.13.5	Lasers (including laser diodes) and LEDs	See below.	P

IEC 60950-1			
Clause	Requirement + Test	Result - Remark	Verdict
4.3.13.5.1	Lasers (including laser diodes)		N/A
	Laser class		—
4.3.13.5.2	Light emitting diodes (LEDs)	IR LED comply with IEC/EN62471. For IR LED: Exempt Group.	P
4.3.13.6	Other types		N/A

4.4	Protection against hazardous moving parts		N/A
4.4.1	General		N/A
4.4.2	Protection in operator access areas		N/A
	Household and home/office document/media shredders		N/A
4.4.3	Protection in restricted access locations		N/A
4.4.4	Protection in service access areas		N/A
4.4.5	Protection against moving fan blades		N/A
4.4.5.1	General		N/A
	Not considered to cause pain or injury. a).....		N/A
	Is considered to cause pain, not injury. b)		N/A
	Considered to cause injury. c)		N/A
4.4.5.2	Protection for users		N/A
	Use of symbol or warning		N/A
4.4.5.3	Protection for service persons		N/A
	Use of symbol or warning		N/A

4.5	Thermal requirements		P
4.5.1	General	See below.	P
4.5.2	Temperature tests	(See appended table 4.5).	P
	Normal load condition per Annex L	Operated in the most unfavorable way of operation given in the operating instructions until steady conditions were established.	—
4.5.3	Temperature limits for materials	(See appended table 4.5).	P
4.5.4	Touch temperature limits	(See appended table 4.5).	P
4.5.5	Resistance to abnormal heat		N/A

4.6	Openings in enclosures		N/A
------------	-------------------------------	--	------------

IEC 60950-1			
Clause	Requirement + Test	Result - Remark	Verdict
4.6.1	Top and side openings	No openings.	N/A
	Dimensions (mm)		—
4.6.2	Bottoms of fire enclosures	No openings.	N/A
	Construction of the bottom, dimensions (mm) ..		—
4.6.3	Doors or covers in fire enclosures		N/A
4.6.4	Openings in transportable equipment		N/A
4.6.4.1	Constructional design measures		N/A
	Dimensions (mm)		—
4.6.4.2	Evaluation measures for larger openings		N/A
4.6.4.3	Use of metallized parts		N/A
4.6.5	Adhesives for constructional purposes		N/A
	Conditioning temperature (°C), time (weeks).....		—

4.7	Resistance to fire		P
4.7.1	Reducing the risk of ignition and spread of flame	See below.	P
	Method 1, selection and application of components wiring and materials	Use of materials with the required flammability classes.	P
	Method 2, application of all of simulated fault condition tests		N/A
4.7.2	Conditions for a fire enclosure	See below.	P
4.7.2.1	Parts requiring a fire enclosure		N/A
4.7.2.2	Parts not requiring a fire enclosure	Circuit supplied by a limited power source complying with 2.5 and with components mounted on materials of Class V-1 or better, the fire enclosure of equipment is not required.	P
4.7.3	Materials		P
4.7.3.1	General	(See appended table 1.5.1).	P
4.7.3.2	Materials for fire enclosures		N/A
4.7.3.3	Materials for components and other parts outside fire enclosures		N/A
4.7.3.4	Materials for components and other parts inside fire enclosures		N/A
4.7.3.5	Materials for air filter assemblies		N/A
4.7.3.6	Materials used in high-voltage components		N/A

IEC 60950-1			
Clause	Requirement + Test	Result - Remark	Verdict
5	ELECTRICAL REQUIREMENTS AND SIMULATED ABNORMAL CONDITIONS		P
5.1	Touch current and protective conductor current		N/A
5.1.1	General		N/A
5.1.2	Configuration of equipment under test (EUT)		N/A
5.1.2.1	Single connection to an a.c. mains supply		N/A
5.1.2.2	Redundant multiple connections to an a.c. mains supply		N/A
5.1.2.3	Simultaneous multiple connections to an a.c. mains supply		N/A
5.1.3	Test circuit		N/A
5.1.4	Application of measuring instrument		N/A
5.1.5	Test procedure		N/A
5.1.6	Test measurements		N/A
	Supply voltage (V)		—
	Measured touch current (mA)		—
	Max. allowed touch current (mA)		—
	Measured protective conductor current (mA)		—
	Max. allowed protective conductor current (mA)...		—
5.1.7	Equipment with touch current exceeding 3,5 mA		N/A
5.1.7.1	General		N/A
5.1.7.2	Simultaneous multiple connections to the supply		N/A
5.1.8	Touch currents to telecommunication networks and cable distribution systems and from telecommunication networks		N/A
5.1.8.1	Limitation of the touch current to a telecommunication network or to a cable distribution system		N/A
	Supply voltage (V)		—
	Measured touch current (mA)		—
	Max. allowed touch current (mA)		—
5.1.8.2	Summation of touch currents from telecommunication networks		N/A
	a) EUT with earthed telecommunication ports		N/A
	b) EUT whose telecommunication ports have no reference to protective earth		N/A

IEC 60950-1			
Clause	Requirement + Test	Result - Remark	Verdict
5.2	Electric strength		N/A
5.2.1	General		N/A
5.2.2	Test procedure		N/A

5.3	Abnormal operating and fault conditions		P
5.3.1	Protection against overload and abnormal operation	See below.	P
5.3.2	Motors		N/A
5.3.3	Transformers		N/A
5.3.4	Functional insulation	Function Insulation complied with the requirements c).	P
5.3.5	Electromechanical components		N/A
5.3.6	Audio amplifiers in ITE		N/A
5.3.7	Simulation of faults	(See appended table 5.3).	P
5.3.8	Unattended equipment		N/A
5.3.9	Compliance criteria for abnormal operating and fault conditions	See below.	P
5.3.9.1	During the tests	No fire occurred. No molten metal was emitted during the tests.	P
5.3.9.2	After the tests		N/A

6	CONNECTION TO TELECOMMUNICATION NETWORKS		N/A
6.1	Protection of telecommunication network service persons, and users of other equipment connected to the network, from hazards in the equipment		N/A
6.1.1	Protection from hazardous voltages		N/A
6.1.2	Separation of the telecommunication network from earth		N/A
6.1.2.1	Requirements		N/A
	Supply voltage (V)		—
	Current in the test circuit (mA)		—
6.1.2.2	Exclusions		N/A

6.2	Protection of equipment users from overvoltages on telecommunication networks		N/A
6.2.1	Separation requirements		N/A
6.2.2	Electric strength test procedure		N/A
6.2.2.1	Impulse test		N/A

IEC 60950-1			
Clause	Requirement + Test	Result - Remark	Verdict
6.2.2.2	Steady-state test		N/A
6.2.2.3	Compliance criteria		N/A

6.3	Protection of the telecommunication wiring system from overheating		N/A
	Max. output current (A)		—
	Current limiting method		—

7	CONNECTION TO CABLE DISTRIBUTION SYSTEMS		N/A
7.1	General		N/A
7.2	Protection of cable distribution system service persons, and users of other equipment connected to the system, from hazardous voltages in the equipment		N/A
7.3	Protection of equipment users from overvoltages on the cable distribution system		N/A
7.4	Insulation between primary circuits and cable distribution systems		N/A
7.4.1	General		N/A
7.4.2	Voltage surge test		N/A
7.4.3	Impulse test		N/A

A	ANNEX A, TESTS FOR RESISTANCE TO HEAT AND FIRE		N/A
A.1	Flammability test for fire enclosures of movable equipment having a total mass exceeding 18 kg, and of stationary equipment (see 4.7.3.2)		N/A
A.1.1	Samples		—
	Wall thickness (mm)		—
A.1.2	Conditioning of samples; temperature (°C)		N/A
A.1.3	Mounting of samples		N/A
A.1.4	Test flame (see IEC 60695-11-3)		N/A
	Flame A, B, C or D		—
A.1.5	Test procedure		N/A
A.1.6	Compliance criteria		N/A
	Sample 1 burning time (s)		—
	Sample 2 burning time (s)		—
	Sample 3 burning time (s)		—

IEC 60950-1			
Clause	Requirement + Test	Result - Remark	Verdict
A.2	Flammability test for fire enclosures of movable equipment having a total mass not exceeding 18 kg, and for material and components located inside fire enclosures (see 4.7.3.2 and 4.7.3.4)		N/A
A.2.1	Samples, material		—
	Wall thickness (mm)		—
A.2.2	Conditioning of samples; temperature (°C)		N/A
A.2.3	Mounting of samples		N/A
A.2.4	Test flame (see IEC 60695-11-4)		N/A
	Flame A, B or C		—
A.2.5	Test procedure		N/A
A.2.6	Compliance criteria		N/A
	Sample 1 burning time (s)		—
	Sample 2 burning time (s)		—
	Sample 3 burning time (s)		—
A.2.7	Alternative test acc. to IEC 60695-11-5, cl. 5 and 9		N/A
	Sample 1 burning time (s)		—
	Sample 2 burning time (s)		—
	Sample 3 burning time (s)		—
A.3	Hot flaming oil test (see 4.6.2)		N/A
A.3.1	Mounting of samples		N/A
A.3.2	Test procedure		N/A
A.3.3	Compliance criterion		N/A
B	ANNEX B, MOTOR TESTS UNDER ABNORMAL CONDITIONS (see 4.7.2.2 and 5.3.2)		N/A
B.1	General requirements		N/A
	Position		—
	Manufacturer		—
	Type		—
	Rated values		—
B.2	Test conditions		N/A
B.3	Maximum temperatures		N/A
B.4	Running overload test		N/A
B.5	Locked-rotor overload test		N/A
	Test duration (days)		—

IEC 60950-1			
Clause	Requirement + Test	Result - Remark	Verdict
	Electric strength test: test voltage (V)		—
B.6	Running overload test for d.c. motors in secondary circuits		N/A
B.6.1	General		N/A
B.6.2	Test procedure		N/A
B.6.3	Alternative test procedure		N/A
B.6.4	Electric strength test; test voltage (V)		N/A
B.7	Locked-rotor overload test for d.c. motors in secondary circuits		N/A
B.7.1	General		N/A
B.7.2	Test procedure		N/A
B.7.3	Alternative test procedure		N/A
B.7.4	Electric strength test; test voltage (V)		N/A
B.8	Test for motors with capacitors		N/A
B.9	Test for three-phase motors		N/A
B.10	Test for series motors		N/A
	Operating voltage (V)		—
C	ANNEX C, TRANSFORMERS (see 1.5.4 and 5.3.3)		N/A
	Position		—
	Manufacturer		—
	Type		—
	Rated values		—
	Method of protection		—
C.1	Overload test		N/A
C.2	Insulation		N/A
	Protection from displacement of windings		N/A
D	ANNEX D, MEASURING INSTRUMENTS FOR TOUCH-CURRENT TESTS (see 5.1.4)		N/A
D.1	Measuring instrument		N/A
D.2	Alternative measuring instrument		N/A
E	ANNEX E, TEMPERATURE RISE OF A WINDING (see 1.4.13)		N/A

IEC 60950-1			
Clause	Requirement + Test	Result - Remark	Verdict
F	ANNEX F, MEASUREMENT OF CLEARANCES AND CREEPAGE DISTANCES (see 2.10 and Annex G)		N/A
G	ANNEX G, ALTERNATIVE METHOD FOR DETERMINING MINIMUM CLEARANCES		N/A
G.1	Clearances		N/A
G.1.1	General		N/A
G.1.2	Summary of the procedure for determining minimum clearances		N/A
G.2	Determination of mains transient voltage (V)		N/A
G.2.1	AC mains supply		N/A
G.2.2	Earthed d.c. mains supplies		N/A
G.2.3	Unearthed d.c. mains supplies		N/A
G.2.4	Battery operation		N/A
G.3	Determination of telecommunication network transient voltage (V)		N/A
G.4	Determination of required withstand voltage (V)		N/A
G.4.1	Mains transients and internal repetitive peaks		N/A
G.4.2	Transients from telecommunication networks		N/A
G.4.3	Combination of transients		N/A
G.4.4	Transients from cable distribution systems		N/A
G.5	Measurement of transient voltages (V)		N/A
	a) Transients from a mains supply		N/A
	For an a.c. mains supply		N/A
	For a d.c. mains supply		N/A
	b) Transients from a telecommunication network		N/A
G.6	Determination of minimum clearances		N/A
H	ANNEX H, IONIZING RADIATION (see 4.3.13)		N/A
J	ANNEX J, TABLE OF ELECTROCHEMICAL POTENTIALS (see 2.6.5.6)		N/A
	Metal(s) used		—
K	ANNEX K, THERMAL CONTROLS (see 1.5.3 and 5.3.8)		N/A
K.1	Making and breaking capacity		N/A
K.2	Thermostat reliability; operating voltage (V)		N/A

IEC 60950-1			
Clause	Requirement + Test	Result - Remark	Verdict
K.3	Thermostat endurance test; operating voltage (V)		N/A
K.4	Temperature limiter endurance; operating voltage (V)		N/A
K.5	Thermal cut-out reliability		N/A
K.6	Stability of operation		N/A

L	ANNEX L, NORMAL LOAD CONDITIONS FOR SOME TYPES OF ELECTRICAL BUSINESS EQUIPMENT (see 1.2.2.1 and 4.5.2)	P
L.1	Typewriters	N/A
L.2	Adding machines and cash registers	N/A
L.3	Erasers	N/A
L.4	Pencil sharpeners	N/A
L.5	Duplicators and copy machines	N/A
L.6	Motor-operated files	N/A
L.7	Other business equipment	(See appended table 1.6.2). P

M	ANNEX M, CRITERIA FOR TELEPHONE RINGING SIGNALS (see 2.3.1)	N/A
M.1	Introduction	N/A
M.2	Method A	N/A
M.3	Method B	N/A
M.3.1	Ringling signal	N/A
M.3.1.1	Frequency (Hz)	—
M.3.1.2	Voltage (V)	—
M.3.1.3	Cadence; time (s), voltage (V)	—
M.3.1.4	Single fault current (mA)	—
M.3.2	Tripping device and monitoring voltage	N/A
M.3.2.1	Conditions for use of a tripping device or a monitoring voltage	N/A
M.3.2.2	Tripping device	N/A
M.3.2.3	Monitoring voltage (V)	N/A

N	ANNEX N, IMPULSE TEST GENERATORS (see 1.5.7.2, 1.5.7.3, 2.10.3.9, 6.2.2.1, 7.3.2, 7.4.3 and Clause G.5)	N/A
N.1	ITU-T impulse test generators	N/A
N.2	IEC 60065 impulse test generator	N/A

IEC 60950-1			
Clause	Requirement + Test	Result - Remark	Verdict
P	ANNEX P, NORMATIVE REFERENCES		—
Q	ANNEX Q, Voltage dependent resistors (VDRs) (see 1.5.9.1)		N/A
	- Preferred climatic categories		N/A
	- Maximum continuous voltage		N/A
	- Combination pulse current		N/A
	Body of the VDR Test according to IEC60695-11-5.....		N/A
	Body of the VDR. Flammability class of material (min. V-1).....		N/A
R	ANNEX R, EXAMPLES OF REQUIREMENTS FOR QUALITY CONTROL PROGRAMMES		N/A
R.1	Minimum separation distances for unpopulated coated printed boards (see 2.10.6.2)		N/A
R.2	Reduced clearances (see 2.10.3)		N/A
S	ANNEX S, PROCEDURE FOR IMPULSE TESTING (see 6.2.2.3)		N/A
S.1	Test equipment		N/A
S.2	Test procedure		N/A
S.3	Examples of waveforms during impulse testing		N/A
T	ANNEX T, GUIDANCE ON PROTECTION AGAINST INGRESS OF WATER (see 1.1.2)		N/A
			—
U	ANNEX U, INSULATED WINDING WIRES FOR USE WITHOUT INTERLEAVED INSULATION (see 2.10.5.4)		N/A
			—
V	ANNEX V, AC POWER DISTRIBUTION SYSTEMS (see 1.6.1)		N/A
V.1	Introduction		N/A
V.2	TN power distribution systems		N/A
W	ANNEX W, SUMMATION OF TOUCH CURRENTS		N/A
W.1	Touch current from electronic circuits		N/A

IEC 60950-1			
Clause	Requirement + Test	Result - Remark	Verdict
W.1.1	Floating circuits		N/A
W.1.2	Earthed circuits		N/A
W.2	Interconnection of several equipments		N/A
W.2.1	Isolation		N/A
W.2.2	Common return, isolated from earth		N/A
W.2.3	Common return, connected to protective earth		N/A
X	ANNEX X, MAXIMUM HEATING EFFECT IN TRANSFORMER TESTS (see clause C.1)		N/A
X.1	Determination of maximum input current		N/A
X.2	Overload test procedure		N/A
Y	ANNEX Y, ULTRAVIOLET LIGHT CONDITIONING TEST (see 4.3.13.3)		N/A
Y.1	Test apparatus		N/A
Y.2	Mounting of test samples		N/A
Y.3	Carbon-arc light-exposure apparatus		N/A
Y.4	Xenon-arc light exposure apparatus		N/A
Z	ANNEX Z, OVERVOLTAGE CATEGORIES (see 2.10.3.2 and Clause G.2)		N/A
AA	ANNEX AA, MANDREL TEST (see 2.10.5.8)		N/A
BB	ANNEX BB, CHANGES IN THE SECOND EDITION		—
CC	ANNEX CC, Evaluation of integrated circuit (IC) current limiters		N/A
CC.1	General		N/A
CC.2	Test program 1.....		N/A
CC.3	Test program 2.....		N/A
CC.4	Test program 3.....		N/A
CC.5	Compliance.....		N/A
DD	ANNEX DD, Requirements for the mounting means of rack-mounted equipment		N/A
DD.1	General		N/A
DD.2	Mechanical strength test, variable N.....		N/A
DD.3	Mechanical strength test, 250N, including end stops.....		N/A

IEC 60950-1			
Clause	Requirement + Test	Result - Remark	Verdict
DD.4	Compliance.....:		N/A
EE	ANNEX EE, Household and home/office document/media shredders		N/A
EE.1	General		N/A
EE.2	Markings and instructions		N/A
	Use of markings or symbols.....:		N/A
	Information of user instructions, maintenance and/or servicing instructions.....:		N/A
EE.3	Inadvertent reactivation test.....:		N/A
EE.4	Disconnection of power to hazardous moving parts:		N/A
	Use of markings or symbols.....:		N/A
EE.5	Protection against hazardous moving parts		N/A
	Test with test finger (Figure 2A)		N/A
	Test with wedge probe (Figure EE1 and EE2)		N/A

IEC 60950-1			
Clause	Requirement + Test	Result - Remark	Verdict

1.5.1	TABLE: List of critical components					P
Object / part No.	Manufacturer / trademark	Type / model	Technical data	Standard (Edition / year)	Mark(s) of conformity ¹⁾	
POE adaptor (Optional)(for Model FD9387-EHTV, FD9387-EHV use)	Interchangeable	Interchangeable	O/P: DC 42.5 - 57 V, 0.59-0.44 A min., 55 °C min., LPS.	IEC60950-1: 2005+A1+A2 EN60950-1: 2006+A11+A1+A12+A2	CB or equivalent	
POE adaptor (Optional)(for Model FD9387-HTV, FD9387-HV, FD9387-HVTPM use)	Interchangeable	Interchangeable	O/P: DC 37 -57 V, 0.31-0.20 A min., 55 °C min., LPS.	IEC60950-1: 2005+A1+A2 EN60950-1: 2006+A11+A1+A12+A2	CB or equivalent	
POE adaptor (Optional)(for Model FD9187-HT, FD9187-H use)	Interchangeable	Interchangeable	O/P: DC 37 -57 V, 0.31-0.20 A min., 50 °C min., LPS.	IEC60950-1: 2005+A1+A2 EN60950-1: 2006+A11+A1+A12+A2	CB or equivalent	
AC Adaptor (Optional) (for Model FD9387-EHTV, FD9387-EHV use)	Interchangeable	Interchangeable	O/P: DC 12 V, 1.9 A min. 55 °C min., LPS.	IEC60950-1: 2005+A1+A2 EN60950-1: 2006+A11+A1+A12+A2	CB or equivalent	
AC Adaptor (Optional) (for Model FD9387-HTV, FD9387-HV, FD9387-HVTPM use)	Interchangeable	Interchangeable	O/P: DC 12 V, 0.87 A min. 55 °C min., LPS.	IEC60950-1: 2005+A1+A2 EN60950-1: 2006+A11+A1+A12+A2	CB or equivalent	
AC Adaptor (Optional) (for Model FD9187-HT, FD9187-H use)	Interchangeable	Interchangeable	O/P: DC 12 V, 0.87 A min. 50 °C min., LPS.	IEC60950-1: 2005+A1+A2 EN60950-1: 2006+A11+A1+A12+A2	CB or equivalent	
Metal enclosure (for Model FD9387-EHTV, FD9387-EHV, FD9387-HTV, FD9387-HV, FD9387-HVTPM)	Interchangeable	Interchangeable	Aluminum, 3.0 mm thickness min.	--	--	
Plastic enclosure (Model FD9187-HT, FD9187-H)	Sabic Japan L L C	943 (f1)	V-2, 2.5 mm thickness min., 120 °C	UL94, UL746C	UL	

IEC 60950-1					
Clause	Requirement + Test			Result - Remark	Verdict
Lens cover	Teijin Limited Resin And Plastic	L-1225Z (#1)(f1)	V-2, 2.5 mm thickness min., 115 °C	UL94, UL746C	UL
Electric double layer capacitor (BT1)	ELNA Co. LTD.	DX Series	Rated 5.5 Vdc, 0.33 F.	--	--
O-ring (Between plastic lens cover and metal enclosure)(for model FD9387-EHTV, FD9387-EHV, FD9387-HTV, FD9387-HV, FD9387-HVTPM use)	Momentive Performance Materials Japan L L C	TSE2186U(aq)	Silicone rubber. Overall see Enclosure/Diagrams ID 3-01 for details.	UL94, UL746C	Test by UL
O-ring (Between top enclosure and bottom enclosure)(for model FD9387-EHTV, FD9387-EHV, FD9387-HTV, FD9387-HV, FD9387-HVTPM use)	Momentive Performance Materials Japan L L C	TSE2186U(aq)	Silicone rubber. Overall see Enclosure/Diagrams ID 3-02 for details.	UL94, UL746C	Test by UL
Gasket for Cable Glands(Hole of LAN cable)(for model FD9387-EHTV, FD9387-EHV, FD9387-HTV, FD9387-HV, FD9387-HVTPM use)	AVC Industrial Corp.	S61(AVC)	Silicone rubber. Overall see Enclosure/ Diagrams ID 3-03 for details.	UL 157	UL
Gasket of Cable Glands (for I/O terminal), if cable is not provided. (Alternate) (for model FD9387-EHTV, FD9387-EHV, FD9387-HTV, FD9387-HV, FD9387-HVTPM use)	Momentive Performance Materials Japan L L C	TSE2186U(aq)	Silicone rubber. Overall see Enclosure/Diagrams ID 3-04 for details.	UL94, UL746C	Test by UL

IEC 60950-1					
Clause	Requirement + Test			Result - Remark	Verdict
POE Transformer (T1) (for Model FD9387-EHTV, FD9387-EHV use)	Matrix Electronics Co., Ltd.	MTSE015	105 °C	--	--
POE Transformer (for Model FD9387-HTV, FD9387-HV, FD9387-HVTPM, FD9187-HT, FD9187-H use)	Matrix Electronics Co., Ltd.	MTSE018	105 °C	--	--
(Alternate)	Audix Technology (Xiamen) Co., Ltd.	STD15-350	105 °C	--	--
(Alternate)	Acroparts Technology Co, Ltd.	13W12V	105 °C	--	--
IR LED (two provided)	Lextar	PR88F03	850 nm., 3.6 W Exempt Group	IEC62471:2006	CB by UL
IR LED (two provided)	Lextar	PR35F0A	850 nm., 2 W Exempt Group	IEC62471:2006	CB by UL
PWB	Interchangeable	Interchangeable	Min. V-1, 105°C	UL796	UL
Supplementary information:					
1) Provided evidence ensures the agreed level of compliance. See OD-CB2039.					

1.5.1	TABLE: Opto Electronic Devices	N/A
Manufacturer		
Type.....		
Separately tested		
Bridging insulation		
External creepage distance		
Internal creepage distance		
Distance through insulation		
Tested under the following conditions		
Input.....		
Output.....		
supplementary information		

IEC 60950-1			
Clause	Requirement + Test	Result - Remark	Verdict

1.6.2	TABLE: Electrical data (in normal conditions)						P
U (V)	I (A)	I _{rated} (A)	P (W)	Fuse #	I _{fuse} (A)	Condition/status	
Model: FD9387-EHTV							
DC 57 V	0.32	0.44	18.24	--	--	Maximum normal load. Condition A	
DC 42.5 V	0.46	0.59	19.55	--	--	Maximum normal load. Condition A	
DC 12 V	1.29	1.90	15.48	--	--	Maximum normal load. Condition A	
Model: FD9387-HTV							
DC 57 V	0.11	0.20	6.27	--	--	Maximum normal load. Condition B	
DC 37 V	0.18	0.31	6.66	--	--	Maximum normal load. Condition B	
DC 12 V	0.45	0.87	5.40	--	--	Maximum normal load. Condition B	
Model: FD9187-HT							
DC 57 V	0.10	0.20	5.70	--	--	Maximum normal load. Condition B	
DC 37 V	0.15	0.31	5.55	--	--	Maximum normal load. Condition B	
DC 12 V	0.38	0.87	4.56	--	--	Maximum normal load. Condition B	
Supplementary information: Max. Normal load: Condition A : The equipment transferred video signal and communicated with PC by WiFi or LAN port (RJ-45), turning on heater of equipment at the same time and operating continuously. Condition B : The equipment transferred video signal and communicated with PC or host device via LAN port (RL-45) then operated continuously.							

2.1.1.5 c) 1)	TABLE: max. V, A, VA test					N/A
Voltage (rated) (V)	Current (rated) (A)	Voltage (max.) (V)	Current (max.) (A)	VA (max.) (VA)		

IEC 60950-1			
Clause	Requirement + Test	Result - Remark	Verdict
supplementary information:			

2.1.1.5 c) 2)	TABLE: stored energy		N/A
Capacitance C (μ F)	Voltage U (V)	Energy E (J)	
supplementary information:			

2.2	TABLE: evaluation of voltage limiting components in SELV circuits			N/A
Component (measured between)	max. voltage (V) (normal operation)		Voltage Limiting Components	
	V peak	V d.c.		
		--	--	
		--	--	
Fault test performed on voltage limiting components	Voltage measured (V) in SELV circuits (V peak or V d.c.)			
supplementary information:				

2.5	TABLE: Limited power sources					P
Circuit output tested:						
Note: Measured Uoc (V) with all load circuits disconnected: See below.						
Components	Test condition (Single fault)	Uoc (V)	I _{sc} (A)		VA	
			Meas.	Limit	Meas.	Limit
Circuit output tested: LAN Port (Supply by DC 12 V)						
Pin 1-8 to RTN	Normal	0	0	8	0	100
Circuit output tested: Terminal Connector (Supply by DC 12 V)						
Pin 1-14 to RTN	Normal	0	0	8	0	100
supplementary information:						
Sc=Short circuit, Oc=Open circuit						

IEC 60950-1			
Clause	Requirement + Test	Result - Remark	Verdict
2.10.2	Table: working voltage measurement		N/A
Location	RMS voltage (V)	Peak voltage (V)	Comments
supplementary information:			

2.10.3 and 2.10.4	TABLE: Clearance and creepage distance measurements						N/A
Clearance (cl) and creepage distance (cr) at/of/between:	U peak (V)	U r.m.s. (V)	Required cl (mm)	cl (mm)	Required cr (mm)	cr (mm)	
Functional:							
Basic/supplementary:							
Reinforced:							
Supplementary information:							

2.10.5	TABLE: Distance through insulation measurements					N/A
Distance through insulation (DTI) at/of:	U peak (V)	U rms (V)	Test volt-age (V)	Required DTI (mm)	DTI (mm)	
Supplementary information:						

4.3.8	TABLE: Batteries								N/A
The tests of 4.3.8 are applicable only when appropriate battery data is not available									N/A
Is it possible to install the battery in a reverse polarity position?									N/A
Non-rechargeable batteries				Rechargeable batteries					
Discharging		Un-intentional charging	Charging		Discharging		Reversed charging		
Meas. current	Manuf. Specs.		Meas. current	Manuf. Specs.	Meas. current	Manuf. Specs.	Meas. current	Manuf. Specs.	

IEC 60950-1										
Clause	Requirement + Test							Result - Remark		Verdict
4.3.8	TABLE: Batteries								N/A	
The tests of 4.3.8 are applicable only when appropriate battery data is not available									N/A	
Is it possible to install the battery in a reverse polarity position?									N/A	
	Non-rechargeable batteries			Rechargeable batteries						
	Discharging		Un-intentional charging	Charging		Discharging		Reversed charging		
	Meas. current	Manuf. Specs.		Meas. current	Manuf. Specs.	Meas. current	Manuf. Specs.	Meas. current	Manuf. Specs.	
Max. current during normal condition										
Max. current during fault condition										
Test results:									Verdict	
- Chemical leaks									N/A	
- Explosion of the battery									N/A	
- Emission of flame or expulsion of molten metal									N/A	
- Electric strength tests of equipment after completion of tests									N/A	
Supplementary information:										

4.3.8	TABLE: Batteries								N/A	
Battery category : (Lithium, NiMh, NiCad, Lithium Ion ...)										
Manufacturer :										
Type / model..... :										
Voltage :										
Capacity..... : mAh										
Tested and Certified by (incl. Ref. No.) :										
Circuit protection diagram:										

MARKINGS AND INSTRUCTIONS (1.7.13)	
Location of replaceable battery	
Language(s)	

IEC 60950-1			
Clause	Requirement + Test	Result - Remark	Verdict
	Close to the battery		
	In the servicing instructions		
	In the operating instructions		

4.5	TABLE: Thermal requirements			P
	Supply voltage (V)	DC 57 V	DC 57 V	—
	Ambient Tmin (°C)	--	--	—
	Ambient Tmax (°C)	--	--	—
	Maximum measured temperature T of part/at.....:	T (°C)		Allowed T _{max} (°C)
Model: FD9387-EHTV				
	Test Condition	Ceiling Mount	Wall mount	--
	PWB near U4	85.1	81.2	105
	PWB near L2	81.0	79.8	105
	T1 coil	84.5	83.3	105
	BT1 body(Super cap)	77.9	73.0	--
	PWB near U1	82.4	79.9	105
	Metal enclosure outside near T1	64.4	64.1	70
	Lens cover Plastic enclosure inside near Camera	70.9	65.2	--
	Lens cover Plastic enclosure outside near Camera	68.3	62.3	95
	Ambient	55.0(23.9)	55.0(24.0)	--
	Test Vltage	DC 42.5 V	DC 42.5 V	--
	Test Condition	Ceiling Mount	Wall mount	--
	PWB near U4	85.0	82.3	105
	PWB near L2	80.5	78.6	105
	T1 coil	83.6	81.8	105
	BT1 body(Super cap)	77.9	72.4	--
	PWB near U1	82.3	78.8	105
	Metal enclosure outside near T1	64.4	63.3	70
	Lens cover Plastic enclosure inside near Camera	70.9	64.2	--
	Lens cover Plastic enclosure outside near Camera	68.3	61.4	95

IEC 60950-1			
Clause	Requirement + Test	Result - Remark	Verdict
Ambient		55.0(23.5) 55.0(23.5)	--
Test Voltage		DC 12 V DC 12 V	--
Test Condition		Ceiling Mount Wall mount	--
PWB near U4		82.1 81.4	105
PWB near L2		69.7 69.8	105
T1 coil		70.0 70.2	105
BT1 body(Super cap)		75.1 71.9	--
PWB near U1		79.2 78.7	105
Metal enclosure outside near T1		61.8 62.3	70
Lens cover Plastic enclosure inside near Camera		68.3 65.1	--
Lens cover Plastic enclosure outside near Camera		65.7 62.3	95
Ambient		55.0(23.1) 55.0(22.9)	--
Model: FD9387-ETV			
Test Voltage		DC 57 V DC 57 V	--
Test Condition		Ceiling Mount Wall mount	--
PWB near U4		83.6 83.6	105
PWB near L2		80.0 77.8	105
T1 coil		82.3 80.5	105
BT1 body(Super cap)		78.1 79.1	--
PWB near U1		84.9 84.7	105
Metal enclosure outside near T1		63.2 63.5	70
Lens cover Plastic enclosure inside near Camera		71.9 68.4	--
Lens cover Plastic enclosure outside near Camera		68.9 64.5	95
Ambient		55.0(24.0) 55.0(23.4)	--
Test Voltage		DC 37 V DC 37 V	--
Test Condition		Ceiling Mount Wall mount	--
PWB near U4		85.7 79.8	105
PWB near L2		82.2 75.7	105
T1 coil		84.1 77.8	105
BT1 body(Super cap)		80.7 76.0	--
PWB near U1		87.8 82.7	105
Metal enclosure outside near T1		65.8 62.0	70

IEC 60950-1				
Clause	Requirement + Test	Result - Remark		Verdict
Lens cover Plastic enclosure inside near Camera		74.1	67.2	--
Lens cover Plastic enclosure outside near Camera		70.8	63.7	95
Ambient		55.0(24.1)	55.0(24.5)	--
Test Voltage		DC 12 V	DC 12 V	--
Test Condition		Ceiling Mount	Wall mount	--
PWB near U4		79.8	78.2	105
PWB near L2		71.5	69.1	105
T1 coil		71.5	69.2	105
BT1 body(Super cap)		76.4	72.7	--
PWB near U1		85.0	82.1	105
Metal enclosure outside near T1		62.3	62.1	70
Lens cover Plastic enclosure inside near Camera		72.0	67.1	--
Lens cover Plastic enclosure outside near Camera		68.1	62.5	95
Ambient		55.0(23.1)	55.0(23.5)	--
Model: FD9187-HT				
Test Voltage		DC 57 V	DC 57 V	--
Test Condition		Ceiling Mount	Wall mount	--
PWB near U4		98.3	92.6	105
PWB near L2		88.7	89.6	105
T1 coil		92.5	91.4	105
BT1 body(Super cap)		86.0	75.5	--
PWB near U1		85.3	81.7	105
Plastic enclosure inside near T1		65.1	68.8	--
Plastic enclosure outside near T1		59.6	63.4	95
Lens cover Plastic enclosure inside near Camera		75.7	65.1	--
Lens cover Plastic enclosure outside near Camera		67.2	57.3	95
Ambient		50.0(24.2)	50.0(24.2)	--
Test Voltage		DC 37 V	DC 37 V	--
Test Condition		Ceiling Mount	Wall mount	--
PWB near U4		98.1	94.3	105
PWB near L2		88.7	87.2	105
T1 coil		91.9	90.1	105

IEC 60950-1							
Clause	Requirement + Test				Result - Remark		Verdict
BT1 body(Super cap)					85.5	79.5	--
PWB near U1					84.9	83.3	105
Plastic enclosure inside near T1					64.3	64.8	--
Plastic enclosure outside near T1					57.7	59.8	95
Lens cover Plastic enclosure inside near Camera					75.0	67.3	--
Lens cover Plastic enclosure outside near Camera					66.3	59.6	95
Ambient					50.0(23.4)	50.0(23.4)	--
Test Voltage					DC 12 V	DC 12 V	--
Test Condition					Ceiling Mount	Wall mount	--
PWB near U4					94.0	91.3	105
PWB near L2					70.7	69.6	105
T1 coil					74.6	73.7	105
BT1 body(Super cap)					81.6	77.1	--
PWB near U1					80.6	79.8	105
Plastic enclosure inside near T1					59.9	59.9	--
Plastic enclosure outside near T1					56.7	57.4	95
Lens cover Plastic enclosure inside near Camera					73.1	66.6	--
Lens cover Plastic enclosure outside near Camera					66.9	60.5	95
Ambient					50.0(23.1)	50.0(23.3)	--
Supplementary information:							
Temperature T of winding:	t ₁ (°C)	R ₁ (Ω)	t ₂ (°C)	R ₂ (Ω)	T (°C)	Allowed T _{max} (°C)	Insulation class
Supplementary information:							
The temperatures were measured under worst case defined in 1.2.2.1 and described in 1.6.2 at voltages as described in 1.4.5.							
With specified ambient temperature in user's manual, therefore the ambient temperature assumed as 55 °C for Model <i>FD9387-EHTV</i> , <i>FD9387-ETV</i>							
With specified ambient temperature in user's manual, therefore the ambient temperature assumed as 50 °C for Model <i>FD9187-HT</i>							

4.5.5	TABLE: Ball pressure test of thermoplastic parts		N/A
	Allowed impression diameter (mm)	≤ 2 mm	—
Part		Test temperature (°C)	Impression diameter (mm)

IEC 60950-1			
Clause	Requirement + Test	Result - Remark	Verdict

Supplementary information:			
----------------------------	--	--	--

4.7	TABLE: Resistance to fire			N/A
------------	----------------------------------	--	--	------------

Part	Manufacturer of material	Type of material	Thickness (mm)	Flammability class	Evidence

Supplementary information:					
----------------------------	--	--	--	--	--

5.1	TABLE: touch current measurement			N/A
------------	---	--	--	------------

Measured between:	Measured (mA)	Limit (mA)	Comments/conditions

supplementary information:			

5.2	TABLE: Electric strength tests, impulse tests and voltage surge tests			N/A
------------	--	--	--	------------

Test voltage applied between:	Voltage shape (AC, DC, impulse, surge)	Test voltage (V)	Breakdown Yes / No

Functional:			

Basic/supplementary:			

Reinforced:			

Supplementary information:			
----------------------------	--	--	--

5.3	TABLE: Fault condition tests			P
------------	-------------------------------------	--	--	----------

	Ambient temperature (°C)	See below.	—
--	--------------------------------	------------	---

	Power source for EUT: Manufacturer, model/type, output rating	--	—
--	---	----	---

Com-ponent No.	Fault	Supply vol-tage (V)	Test time	Fuse #	Fuse cur-rent (A)	Observation
----------------	-------	---------------------	-----------	--------	-------------------	-------------

Model FD9387-EHTV						
--------------------------	--	--	--	--	--	--

IEC 60950-1							
Clause	Requirement + Test				Result - Remark		Verdict
BT1 (Gold-Cap)	+ to - Short	DC 57 V	7 hr	--	--	No Explosion, no Leakage, No hazards Max Temp. Ambient: 22.5 °C BT1 body: 52.2 °C	
BT1 (Gold-Cap)	R328 Short	DC 57 V	7 hr	--	--	No Explosion, no Leakage, No hazards Max Temp. Ambient: 22.7 °C BT1 body: 51.3 °C	
BT1 (Gold-Cap)	D40 Short	DC 57 V	7 hr	--	--	No Explosion, no Leakage, No hazards Max Temp. Ambient: 24.4 °C BT1 body: 51.3 °C	
Main board Heater on	Q14 Pin D-S short	DC 57 V	7 hr	--	--	Unit normal operation, No hazards, no damaged Max Temp. Ambient: 23.8 °C PWB near U4: 103.5 °C	
Sensor board Heater on	Q22 Pin D-S short	DC 57 V	7 hr	--	--	Unit normal operation, No hazards, no damaged Max Temp. Ambient: 22.6 °C PWB near U1: 103.5 °C	
Overload of operator accessible connector test for US Deviation.							
LAN Port							
Pin 1-8 to RTN	Overload	DC 12 V	--	--	--	Open circuit voltage 0 V	
Terminal Connector							
Pin 1-14 to RTN	Overload	DC 12 V	--	--	--	Open circuit voltage 0 V	
Supplementary information:							

C.2	TABLE: transformers						N/A
Loc.	Tested insulation	Working voltage peak / V	Working voltage rms / V	Required electric strength	Required clearance / mm	Required creepage distance / mm	Required distance thr. insul.
		(2.10.2)	(2.10.2)	(5.2)	(2.10.3)	(2.10.4)	(2.10.5)

IEC 60950-1							
Clause	Requirement + Test			Result - Remark		Verdict	
Loc.	Tested insulation			Test voltage / V	Measured clearance / mm	Measured creepage dist. / mm	Measured distance thr. insul. / mm; number of layers
supplementary information:							

C.2	TABLE: transformers	N/A
Transformer		

IEC60950_1F - ATTACHMENT			
Clause	Requirement + Test	Result - Remark	Verdict

ATTACHMENT TO TEST REPORT IEC 60950-1 EUROPEAN GROUP DIFFERENCES AND NATIONAL DIFFERENCES Information technology equipment – Safety – Part 1: General requirements			
Differences according to.....:		EN 60950-1:2006/A11:2009/A1:2010/A12:2011/A2:2013	
Attachment Form No.....:		EU_GD_IEC60950_1F	
Attachment Originator		SGS Fimko Ltd	
Master Attachment		Date 2014-02	
Copyright © 2014 IEC System for Conformity Testing and Certification of Electrical Equipment (IECEE), Geneva, Switzerland. All rights reserved.			

EN 60950-1:2006/A11:2009/A1:2010/A12:2011/A2:2013 – CENELEC COMMON MODIFICATIONS

IEC 60950-1, GROUP DIFFERENCES (CENELEC common modifications EN)			
Clause	Requirement + Test	Result - Remark	Verdict
	Clauses, subclauses, notes, tables and figures which are additional to those in IEC60950-1 and it's amendmets are prefixed "Z"		P
Contents (A2:2013)	Add the following annexes: Annex ZA (normative) Normative references to international publications with their corresponding European publications Annex ZB (normative) Special national conditions Annex ZD (informative) IEC and CENELEC code designations for flexible cords		P
General	Delete all the "country" notes in the reference document (IEC 60950-1:2005) according to the following list: 1.4.8 Note 2 1.5.1 Note 2 & 3 1.5.7.1 Note 1.5.8 Note 2 1.5.9.4 Note 1.7.2.1 Note 4, 5 & 6 2.2.3 Note 2.2.4 Note 2.3.2 Note 2.3.2.1 Note 2 2.3.4 Note 2 2.6.3.3 Note 2 & 3 2.7.1 Note 2.10.3.2 Note 2 2.10.5.13 Note 3 3.2.1.1 Note 3.2.4 Note 3. 2.5.1 Note 2 4.3.6 Note 1 & 2 4.7 Note 4 4.7.2.2 Note 4.7.3.1 Note 2 5.1.7.1 Note 3 & 4 5.3.7 Note 1 6 Note 2 & 5 6.1.2.1 Note 2 6.1.2.2 Note 6.2.2 Note 6.2.2.1 Note 2 6.2.2.2 Note 7.1 Note 3 7.2 Note 7.3 Note 1 & 2 G.2.1 Note 2 Annex H Note 2		P

IEC60950_1F - ATTACHMENT			
Clause	Requirement + Test	Result - Remark	Verdict

IEC 60950-1, GROUP DIFFERENCES (CENELEC common modifications EN)			
Clause	Requirement + Test	Result - Remark	Verdict
General (A1:2010)	Delete all the "country" notes in the reference document (IEC 60950-1:2005/A1:2010) according to the following list: 1.5.7.1 Note 6.1.2.1 Note 2 6.2.2.1 Note 2 EE.3 Note		P
General (A2:2013)	Delete all the "country" notes in the reference document (IEC 60950-1:2005/A2:2013) according to the following list: 2.7.1 Note * 2.10.3.1 Note 2 6.2.2. Note * Note of secretary: Text of Common Modification remains unchanged.		P
1.1.1 (A1:2010)	Replace the text of NOTE 3 by the following. NOTE 3 The requirements of EN 60065 may also be used to meet safety requirements for multimedia equipment. See IEC Guide 112, Guide on the safety of multimedia equipment. For television sets EN 60065 applies.		N/A
1.3.Z1	Add the following subclause: 1.3.Z1 Exposure to excessive sound pressure The apparatus shall be so designed and constructed as to present no danger when used for its intended purpose, either in normal operating conditions or under fault conditions, particularly providing protection against exposure to excessive sound pressures from headphones or earphones. NOTE Z1 A new method of measurement is described in EN 50332-1, Sound system equipment: Headphones and earphones associated with portable audio equipment - Maximum sound pressure level measurement methodology and limit considerations - Part 1: General method for "one package equipment", and in EN 50332-2, Sound system equipment: Headphones and earphones associated with portable audio equipment - Maximum sound pressure level measurement methodology and limit considerations - Part 2: Guidelines to associate sets with headphones coming from different manufacturers.		N/A
(A12:2011)	In EN 60950-1:2006/A12:2011 Delete the addition of 1.3.Z1 / EN 60950-1:2006 Delete the definition 1.2.3.Z1 / EN 60950-1:2006 /A1:2010	Deleted.	N/A
1.5.1 (Added info*)	Add the following NOTE: NOTE Z1 The use of certain substances in electrical and electronic equipment is restricted within the EU: see Directive 2002/95/EC. New Directive 2011/65/11 *	Added.	P

IEC60950_1F - ATTACHMENT			
Clause	Requirement + Test	Result - Remark	Verdict

IEC 60950-1, GROUP DIFFERENCES (CENELEC common modifications EN)			
Clause	Requirement + Test	Result - Remark	Verdict
1.7.2.1 (A1:2010)	In addition, for a PORTABLE SOUND SYSTEM, the instructions shall include a warning that excessive sound pressure from earphones and headphones can cause hearing loss.		N/A
1.7.2.1 (A12:2011)	In EN 60950-1:2006/A12:2011 Delete NOTE Z1 and the addition for Portable Sound System. Add the following clause and annex to the existing standard and amendments.	Deleted.	N/A
	Zx Protection against excessive sound pressure from personal music players		N/A

IEC60950_1F - ATTACHMENT			
Clause	Requirement + Test	Result - Remark	Verdict

IEC 60950-1, GROUP DIFFERENCES (CENELEC common modifications EN)			
Clause	Requirement + Test	Result - Remark	Verdict
	<p>Zx.1 General</p> <p>This sub-clause specifies requirements for protection against excessive sound pressure from personal music players that are closely coupled to the ear. It also specifies requirements for earphones and headphones intended for use with personal music players.</p> <p>A personal music player is a portable equipment for personal use, that:</p> <ul style="list-style-type: none"> – is designed to allow the user to listen to recorded or broadcast sound or video; and – primarily uses headphones or earphones that can be worn in or on or around the ears; and – allows the user to walk around while in use. <p>NOTE 1 Examples are hand-held or body-worn portable CD players, MP3 audio players, mobile phones with MP3 type features, PDA's or similar equipment.</p> <p>A personal music player and earphones or headphones intended to be used with personal music players shall comply with the requirements of this sub-clause.</p> <p>The requirements in this sub-clause are valid for music or video mode only.</p> <p>The requirements do not apply:</p> <ul style="list-style-type: none"> – while the personal music player is connected to an external amplifier; or – while the headphones or earphones are not used. <p>NOTE 2 An external amplifier is an amplifier which is not part of the personal music player or the listening device, but which is intended to play the music as a standalone music player.</p> <p>The requirements do not apply to:</p> <ul style="list-style-type: none"> – hearing aid equipment and professional equipment; <p>NOTE 3 Professional equipment is equipment sold through special sales channels. All products sold through normal electronics stores are considered not to be professional equipment.</p>		N/A

IEC60950_1F - ATTACHMENT			
Clause	Requirement + Test	Result - Remark	Verdict

IEC 60950-1, GROUP DIFFERENCES (CENELEC common modifications EN)			
Clause	Requirement + Test	Result - Remark	Verdict
	<p>– analogue personal music players (personal music players without any kind of digital processing of the sound signal) that are brought to the market before the end of 2015.</p> <p>NOTE 4 This exemption has been allowed because this technology is falling out of use and it is expected that within a few years it will no longer exist. This exemption will not be extended to other technologies.</p> <p>For equipment which is clearly designed or intended for use by young children, the limits of EN 71-1 apply.</p>		N/A
	<p>Zx.2 Equipment requirements</p> <p>No safety provision is required for equipment that complies with the following:</p> <ul style="list-style-type: none"> – equipment provided as a package (personal music player with its listening device), where the acoustic output $L_{Aeq,T}$ is ≤ 85 dBA measured while playing the fixed “programme simulation noise” as described in EN 50332-1; and – a personal music player provided with an analogue electrical output socket for a listening device, where the electrical output is ≤ 27 mV measured as described in EN 50332-2, while playing the fixed “programme simulation noise” as described in EN 50332-1. <p>NOTE 1 Wherever the term acoustic output is used in this clause, the 30 s A-weighted equivalent sound pressure level $L_{Aeq,T}$ is meant. See also Zx.5 and Annex Zx.</p> <p>All other equipment shall:</p> <ol style="list-style-type: none"> a) protect the user from unintentional acoustic outputs exceeding those mentioned above; and b) have a standard acoustic output level not exceeding those mentioned above, and automatically return to an output level not exceeding those mentioned above when the power is switched off; and 		N/A

IEC60950_1F - ATTACHMENT			
Clause	Requirement + Test	Result - Remark	Verdict

IEC 60950-1, GROUP DIFFERENCES (CENELEC common modifications EN)			
Clause	Requirement + Test	Result - Remark	Verdict
	<p>c) provide a means to actively inform the user of the increased sound pressure when the equipment is operated with an acoustic output exceeding those mentioned above. Any means used shall be acknowledged by the user before activating a mode of operation which allows for an acoustic output exceeding those mentioned above. The acknowledgement does not need to be repeated more than once every 20 h of cumulative listening time; and</p> <p>NOTE 2 Examples of means include visual or audible signals. Action from the user is always required.</p> <p>NOTE 3 The 20 h listening time is the accumulative listening time, independent how often and how long the personal music player has been switched off.</p> <p>d) have a warning as specified in Zx.3; and</p> <p>e) not exceed the following:</p> <ol style="list-style-type: none"> 1) equipment provided as a package (player with its listening device), the acoustic output shall be ≤ 100 dBA measured while playing the fixed "programme simulation noise" described in EN 50332-1; and 2) a personal music player provided with an analogue electrical output socket for a listening device, the electrical output shall be ≤ 150 mV measured as described in EN 50332-2, while playing the fixed "programme simulation noise" described in EN 50332-1. <p>For music where the average sound pressure (long term $L_{Aeq,T}$) measured over the duration of the song is lower than the average produced by the programme simulation noise, the warning does not need to be given as long as the average sound pressure of the song is below the basic limit of 85 dBA. In this case T becomes the duration of the song.</p> <p>NOTE 4 Classical music typically has an average sound pressure (long term $L_{Aeq,T}$) which is much lower than the average programme simulation noise. Therefore, if the player is capable to analyse the song and compare it with the programme simulation noise, the warning does not need to be given as long as the average sound pressure of the song is below the basic limit of 85 dBA.</p> <p>For example, if the player is set with the programme simulation noise to 85 dBA, but the average music level of the song is only 65 dBA, there is no need to give a warning or ask an acknowledgement as long as the average sound level of the song is not above the basic limit of 85 dBA.</p>		N/A

IEC60950_1F - ATTACHMENT			
Clause	Requirement + Test	Result - Remark	Verdict
IEC 60950-1, GROUP DIFFERENCES (CENELEC common modifications EN)			
	<p>Zx.3 Warning</p> <p>The warning shall be placed on the equipment, or on the packaging, or in the instruction manual and shall consist of the following:</p> <ul style="list-style-type: none"> – the symbol of Figure 1 with a minimum height of 5 mm; and – the following wording, or similar: <p>“To prevent possible hearing damage, do not listen at high volume levels for long periods.”</p> <div style="text-align: center;">  </div> <p>Figure 1 – Warning label (IEC 60417-6044)</p> <p>Alternatively, the entire warning may be given through the equipment display during use, when the user is asked to acknowledge activation of the higher level.</p>		N/A
	Zx.4 Requirements for listening devices (headphones and earphones)		N/A
	<p>Zx.4.1 Wired listening devices with analogue input</p> <p>With 94 dBA sound pressure output $L_{Aeq,T}$, the input voltage of the fixed “programme simulation noise” described in EN 50332-2 shall be ≥ 75 mV.</p> <p>This requirement is applicable in any mode where the headphones can operate (active or passive), including any available setting (for example built-in volume level control).</p> <p>NOTE The values of 94 dBA – 75 mV correspond with 85dBA – 27 mV and 100 dBA – 150 mV.</p>		N/A

IEC60950_1F - ATTACHMENT			
Clause	Requirement + Test	Result - Remark	Verdict

IEC 60950-1, GROUP DIFFERENCES (CENELEC common modifications EN)			
Clause	Requirement + Test	Result - Remark	Verdict
	<p>Zx.4.2 Wired listening devices with digital input</p> <p>With any playing device playing the fixed “programme simulation noise” described in EN 50332-1 (and respecting the digital interface standards, where a digital interface standard exists that specifies the equivalent acoustic level), the acoustic output $L_{Aeq,T}$ of the listening device shall be ≤ 100 dBA.</p> <p>This requirement is applicable in any mode where the headphones can operate, including any available setting (for example built-in volume level control, additional sound feature like equalization, etc.).</p> <p>NOTE An example of a wired listening device with digital input is a USB headphone.</p>		N/A
	<p>Zx.4.3 Wireless listening devices</p> <p>In wireless mode:</p> <ul style="list-style-type: none"> – with any playing and transmitting device playing the fixed programme simulation noise described in EN 50332-1; and – respecting the wireless transmission standards, where an air interface standard exists that specifies the equivalent acoustic level; and – with volume and sound settings in the listening device (for example built-in volume level control, additional sound feature like equalization, etc.) set to the combination of positions that maximize the measured acoustic output for the abovementioned programme simulation noise, the acoustic output $L_{Aeq,T}$ of the listening device shall be ≤ 100 dBA. <p>NOTE An example of a wireless listening device is a Bluetooth headphone.</p>		N/A

IEC60950_1F - ATTACHMENT			
Clause	Requirement + Test	Result - Remark	Verdict

IEC 60950-1, GROUP DIFFERENCES (CENELEC common modifications EN)			
Clause	Requirement + Test	Result - Remark	Verdict
	<p>Zx.5 Measurement methods</p> <p>Measurements shall be made in accordance with EN 50332-1 or EN 50332-2 as applicable. Unless stated otherwise, the time interval T shall be 30 s.</p> <p>NOTE Test method for wireless equipment provided without listening device should be defined.</p>		N/A
2.7.1	<p>Replace the subclause as follows:</p> <p>Basic requirements</p> <p>To protect against excessive current, short-circuits and earth faults in PRIMARY CIRCUITS, protective devices shall be included either as integral parts of the equipment or as parts of the building installation, subject to the following, a), b) and c):</p> <p>a) except as detailed in b) and c), protective devices necessary to comply with the requirements of 5.3 shall be included as parts of the equipment;</p> <p>b) for components in series with the mains input to the equipment such as the supply cord, appliance coupler, r.f.i. filter and switch, short-circuit and earth fault protection may be provided by protective devices in the building installation;</p>		N/A
	<p>c) it is permitted for PLUGGABLE EQUIPMENT TYPE B or PERMANENTLY CONNECTED EQUIPMENT, to rely on dedicated overcurrent and short-circuit protection in the building installation, provided that the means of protection, e.g. fuses or circuit breakers, is fully specified in the installation instructions.</p> <p>If reliance is placed on protection in the building installation, the installation instructions shall so state, except that for PLUGGABLE EQUIPMENT TYPE A the building installation shall be regarded as providing protection in accordance with the rating of the wall socket outlet.</p>		N/A
2.7.2	This subclause has been declared 'void'.		N/A
3.2.3	Delete the NOTE in Table 3A, and delete also in this table the conduit sizes in parentheses.		N/A

IEC60950_1F - ATTACHMENT			
Clause	Requirement + Test	Result - Remark	Verdict

IEC 60950-1, GROUP DIFFERENCES (CENELEC common modifications EN)									
Clause	Requirement + Test	Result - Remark	Verdict						
3.2.5.1	<p>Replace “60245 IEC 53” by “H05 RR-F”; “60227 IEC 52” by “H03 VV-F or H03 VVH2-F”; “60227 IEC 53” by “H05 VV-F or H05 VVH2-F2”.</p> <p>In Table 3B, replace the first four lines by the following:</p> <table style="margin-left: 40px;"> <tr> <td>Up to and including 6 </td> <td>0,75^{a)} </td> </tr> <tr> <td>Over 6 up to and including 10 </td> <td>(0,75)^{b)} 1,0 </td> </tr> <tr> <td>Over 10 up to and including 16 </td> <td>(1,0)^{c)} 1,5 </td> </tr> </table> <p>In the conditions applicable to Table 3B delete the words “in some countries” in condition^{a)}.</p> <p>In NOTE 1, applicable to Table 3B, delete the second sentence.</p>	Up to and including 6	0,75 ^{a)}	Over 6 up to and including 10	(0,75) ^{b)} 1,0	Over 10 up to and including 16	(1,0) ^{c)} 1,5		N/A
Up to and including 6	0,75 ^{a)}								
Over 6 up to and including 10	(0,75) ^{b)} 1,0								
Over 10 up to and including 16	(1,0) ^{c)} 1,5								
3.2.5.1 (A2:2013)	NOTE Z1 . The harmonised code designations corresponding to the IEC cord types are given in Annex ZD		N/A						
3.3.4	<p>In Table 3D, delete the fourth line: conductor sizes for 10 to 13 A, and replace with the following:</p> <table style="margin-left: 40px;"> <tr> <td>Over 10 up to and including 16 </td> <td>1,5 to 2,5 </td> <td>1,5 to 4 </td> </tr> </table> <p>Delete the fifth line: conductor sizes for 13 to 16 A</p>	Over 10 up to and including 16	1,5 to 2,5	1,5 to 4		N/A			
Over 10 up to and including 16	1,5 to 2,5	1,5 to 4							
4.3.13.6 (A1:2010)	<p>Replace the existing NOTE by the following:</p> <p>NOTE Z1 Attention is drawn to: 1999/519/EC: Council Recommendation on the limitation of exposure of the general public to electromagnetic fields 0 Hz to 300 GHz, and 2006/25/EC: Directive on the minimum health and safety requirements regarding the exposure of workers to risks arising from physical agents (artificial optical radiation).</p>		N/A						
	Standards taking into account mentioned Recommendation and Directive which demonstrate compliance with the applicable EU Directive are indicated in the OJEC.		N/A						

IEC60950_1F - ATTACHMENT			
Clause	Requirement + Test	Result - Remark	Verdict

IEC 60950-1, GROUP DIFFERENCES (CENELEC common modifications EN)			
Clause	Requirement + Test	Result - Remark	Verdict
Annex H	<p>Replace the last paragraph of this annex by: At any point 10 cm from the surface of the OPERATOR ACCESS AREA, the dose rate shall not exceed 1 μSv/h (0,1 mR/h) (see NOTE). Account is taken of the background level.</p> <p>Replace the notes as follows: NOTE These values appear in Directive 96/29/Euratom. Delete NOTE 2.</p>		N/A
Bibliography	Additional EN standards.		—

ZA	NORMATIVE REFERENCES TO INTERNATIONAL PUBLICATIONS WITH THEIR CORRESPONDING EUROPEAN PUBLICATIONS		—
-----------	--	--	---

ZB ANNEX (NORMATIVE) SPECIAL NATIONAL CONDITIONS (EN)			
Clause	Requirement + Test	Result - Remark	Verdict
1.2.4.1	In Denmark , certain types of Class I appliances (see 3.2.1.1) may be provided with a plug not establishing earthing conditions when inserted into Danish socket-outlets.		N/A
1.2.13.14 (A11:2009)	In Norway and Sweden , for requirements see 1.7.2.1 and 7.3 of this annex.		N/A
1.5.7.1 (A11:2009)	In Finland, Norway and Sweden , resistors bridging BASIC INSULATION in CLASS I PLUGGABLE EQUIPMENT TYPE A must comply with the requirements in 1.5.7.1. In addition when a single resistor is used, the resistor must withstand the resistor test in 1.5.7.2.		N/A
1.5.8	In Norway , due to the IT power system used (see annex V, Figure V.7), capacitors are required to be rated for the applicable line-to-line voltage (230 V).		N/A
1.5.9.4	In Finland, Norway and Sweden , the third dashed sentence is applicable only to equipment as defined in 6.1.2.2 of this annex.		N/A

IEC60950_1F - ATTACHMENT			
Clause	Requirement + Test	Result - Remark	Verdict

ZB ANNEX (NORMATIVE) SPECIAL NATIONAL CONDITIONS (EN)			
Clause	Requirement + Test	Result - Remark	Verdict
1.7.2.1	<p>In Finland, Norway and Sweden, CLASS I PLUGGABLE EQUIPMENT TYPE A intended for connection to other equipment or a network shall, if safety relies on connection to protective earth or if surge suppressors are connected between the network terminals and accessible parts, have a marking stating that the equipment must be connected to an earthed mains socket-outlet. The marking text in the applicable countries shall be as follows:</p> <p>In Finland: "Laitte on liitettävä suojakoskettimilla varustettuun pistorasiaan"</p> <p>In Norway: "Apparatet må tilkoples jordet stikkontakt"</p> <p>In Sweden: "Apparaten skall anslutas till jordat uttag"</p>		N/A
1.7.2.1 (A11:2009)	<p>In Norway and Sweden, the screen of the cable distribution system is normally not earthed at the entrance of the building and there is normally no equipotential bonding system within the building. Therefore the protective earthing of the building installation need to be isolated from the screen of a cable distribution system.</p> <p>It is however accepted to provide the insulation external to the equipment by an adapter or an interconnection cable with galvanic isolator, which may be provided by e.g. a retailer.</p> <p>The user manual shall then have the following or similar information in Norwegian and Swedish language respectively, depending on in what country the equipment is intended to be used in:</p> <p>"Equipment connected to the protective earthing of the building installation through the mains connection or through other equipment with a connection to protective earthing – and to a cable distribution system using coaxial cable, may in some circumstances create a fire hazard. Connection to a cable distribution system has therefore to be provided through a device providing electrical isolation below a certain frequency range (galvanic isolator, see EN 60728-11)."</p>		

IEC60950_1F - ATTACHMENT			
Clause	Requirement + Test	Result - Remark	Verdict

ZB ANNEX (NORMATIVE) SPECIAL NATIONAL CONDITIONS (EN)			
Clause	Requirement + Test	Result - Remark	Verdict
	<p>NOTE In Norway, due to regulation for installations of cable distribution systems, and in Sweden, a galvanic isolator shall provide electrical insulation below 5 MHz. The insulation shall withstand a dielectric strength of 1,5 kV r.m.s., 50 Hz or 60 Hz, for 1 min.</p> <p>Translation to Norwegian (the Swedish text will also be accepted in Norway): "Utstyr som er koplet til beskyttelsesjord via nettplugg og/eller via annet jordtilkoplet utstyr – og er tilkoplet et kabel-TV nett, kan forårsake brannfare. For å unngå dette skal det ved tilkopling av utstyret til kabel-TV nettet installeres en galvanisk isolator mellom utstyret og kabel- TV nettet."</p> <p>Translation to Swedish: "Utrustning som är kopplad till skyddsjord via jordat vägguttag och/eller via annan utrustning och samtidigt är kopplad till kabel-TV nät kan i vissa fall medföra risk för brand. För att undvika detta skall vid anslutning av utrustningen till kabel-TV nät galvanisk isolator finnas mellan utrustningen och kabel-TV nätet."</p>		N/A
1.7.2.1 (A2:2013)	<p>In Denmark, CLASS I PLUGGABLE EQUIPMENT TYPE A intended for connection to other equipment or a network shall, if safety relies on connection to protective earth or if surge suppressors are connected between the network terminals and accessible parts, have a marking stating that the equipment must be connected to an earthed mains socket-outlet.</p> <p>The marking text in Denmark shall be as follows: In Denmark: "Apparatets stikprop skal tilsluttes en stikkontakt med jord, som giver forbindelse til stikproppens jord."</p>		N/A

IEC60950_1F - ATTACHMENT			
Clause	Requirement + Test	Result - Remark	Verdict

ZB ANNEX (NORMATIVE) SPECIAL NATIONAL CONDITIONS (EN)			
Clause	Requirement + Test	Result - Remark	Verdict
1.7.5	In Denmark , socket-outlets for providing power to other equipment shall be in accordance with the Heavy Current Regulations, Section 107-2-D1, Standard Sheet DK 1-3a, DK 1-5a or DK 1-7a, when used on Class I equipment. For STATIONARY EQUIPMENT the socket-outlet shall be in accordance with Standard Sheet DK 1-1b or DK 1-5a.		N/A
1.7.5 (A11:2009)	For CLASS II EQUIPMENT the socket outlet shall be in accordance with Standard Sheet DKA 1-4a.		
1.7.5 (A2:2013)	In Denmark , socket-outlets for providing power to other equipment shall be in accordance with the DS 60884-2-D1:2011. For class I equipment the following Standard Sheets are applicable: DK 1-3a, DK 1-1c, DK 1-1d, DK 1-5a or DK 1-7a, with the exception for STATIONARY EQUIPMENT where the socket-outlets shall be in accordance with Standard Sheet DK 1-1b, DK 1-1c, DK 1-1d or DK 1-5a. Socket outlets intended for providing power to Class II apparatus with a rated current of 2,5 A shall be in accordance with DS 60884-2-D1 standard sheet DKA 1-4a. Other current rating socket outlets shall be in compliance with by DS 60884-2-D1 Standard Sheet DKA 1-3a or DKA 1-3b. Justification the Heavy Current Regulations, 6c		N/A
2.2.4	In Norway , for requirements see 1.7.2.1, 6.1.2.1 and 6.1.2.2 of this annex.		N/A
2.3.2	In Finland, Norway and Sweden there are additional requirements for the insulation. See 6.1.2.1 and 6.1.2.2 of this annex.		N/A
2.3.4	In Norway , for requirements see 1.7.2.1, 6.1.2.1 and 6.1.2.2 of this annex.		N/A
2.6.3.3	In the United Kingdom , the current rating of the circuit shall be taken as 13 A, not 16 A.		N/A

IEC60950_1F - ATTACHMENT			
Clause	Requirement + Test	Result - Remark	Verdict

ZB ANNEX (NORMATIVE) SPECIAL NATIONAL CONDITIONS (EN)			
Clause	Requirement + Test	Result - Remark	Verdict
2.7.1	In the United Kingdom , to protect against excessive currents and short-circuits in the PRIMARY CIRCUIT of DIRECT PLUG-IN EQUIPMENT, tests according to 5.3 shall be conducted, using an external protective device rated 30 A or 32 A. If these tests fail, suitable protective devices shall be included as integral parts of the DIRECT PLUG-IN EQUIPMENT, so that the requirements of 5.3 are met.		N/A
2.10.5.13	In Finland, Norway and Sweden , there are additional requirements for the insulation, see 6.1.2.1 and 6.1.2.2 of this annex.		N/A
3.2.1.1	In Switzerland , supply cords of equipment having a RATED CURRENT not exceeding 10 A shall be provided with a plug complying with SEV 1011 or IEC 60884-1 and one of the following dimension sheets: SEV 6532-2.1991 Plug Type 15 3P+N+PE 250/400 V, 10 A SEV 6533-2.1991 Plug Type 11 L+N 250 V, 10 A SEV 6534-2.1991 Plug Type 12 L+N+PE 250 V, 10 A In general, EN 60309 applies for plugs for currents exceeding 10 A. However, a 16 A plug and socket-outlet system is being introduced in Switzerland, the plugs of which are according to the following dimension sheets, published in February 1998: SEV 5932-2.1998: Plug Type 25 , 3L+N+PE 230/400 V, 16 A SEV 5933-2.1998: Plug Type 21, L+N, 250 V, 16A SEV 5934-2.1998: Plug Type 23, L+N+PE 250 V, 16A		N/A

IEC60950_1F - ATTACHMENT			
Clause	Requirement + Test	Result - Remark	Verdict

ZB ANNEX (NORMATIVE) SPECIAL NATIONAL CONDITIONS (EN)			
Clause	Requirement + Test	Result - Remark	Verdict
3.2.1.1	<p>In Denmark, supply cords of single-phase equipment having a rated current not exceeding 13 A shall be provided with a plug according to the Heavy Current Regulations, Section 107-2-D1.</p> <p>CLASS I EQUIPMENT provided with socket-outlets with earth contacts or which are intended to be used in locations where protection against indirect contact is required according to the wiring rules shall be provided with a plug in accordance with standard sheet DK 2-1a or DK 2-5a.</p> <p>If poly-phase equipment and single-phase equipment having a RATED CURRENT exceeding 13 A is provided with a supply cord with a plug, this plug shall be in accordance with the Heavy Current Regulations, Section 107-2-D1 or EN 60309-2.</p>		N/A
3.2.1.1 (A2:2013)	<p>In Denmark, supply cords of single-phase equipment having a rated current not exceeding 13 A shall be provided with a plug according to DS 60884-2-D1.</p> <p>CLASS I EQUIPMENT provided with socket-outlets with earth contacts or which are intended to be used in locations where protection against indirect contact is required according to the wiring rules shall be provided with a plug in accordance with standard sheet DK 2-1a or DK 2-5a.</p> <p>If a single-phase equipment having a RATED CURRENT exceeding 13 A or if a poly-phase equipment is provided with a supply cord with a plug, this plug shall be in accordance with the standard sheets DK 6-1a in DS 60884-2-D1 or EN 60309-2.</p> <p>Justification the Heavy Current Regulations, 6c</p>		N/A

IEC60950_1F - ATTACHMENT			
Clause	Requirement + Test	Result - Remark	Verdict

ZB ANNEX (NORMATIVE) SPECIAL NATIONAL CONDITIONS (EN)			
Clause	Requirement + Test	Result - Remark	Verdict
3.2.1.1	<p>In Spain, supply cords of single-phase equipment having a rated current not exceeding 10 A shall be provided with a plug according to UNE 20315:1994.</p> <p>Supply cords of single-phase equipment having a rated current not exceeding 2,5 A shall be provided with a plug according to UNE-EN 50075:1993.</p> <p>CLASS I EQUIPMENT provided with socket-outlets with earth contacts or which are intended to be used in locations where protection against indirect contact is required according to the wiring rules, shall be provided with a plug in accordance with standard UNE 20315:1994.</p> <p>If poly-phase equipment is provided with a supply cord with a plug, this plug shall be in accordance with UNE-EN 60309-2.</p>		N/A
3.2.1.1	<p>In the United Kingdom, apparatus which is fitted with a flexible cable or cord and is designed to be connected to a mains socket conforming to BS 1363 by means of that flexible cable or cord and plug, shall be fitted with a 'standard plug' in accordance with Statutory Instrument 1768:1994 - The Plugs and Sockets etc. (Safety) Regulations 1994, unless exempted by those regulations.</p> <p>NOTE 'Standard plug' is defined in SI 1768:1994 and essentially means an approved plug conforming to BS 1363 or an approved conversion plug.</p>		N/A
3.2.1.1	<p>In Ireland, apparatus which is fitted with a flexible cable or cord and is designed to be connected to a mains socket conforming to I.S. 411 by means of that flexible cable or cord and plug, shall be fitted with a 13 A plug in accordance with Statutory Instrument 525:1997 - National Standards Authority of Ireland (section 28) (13 A Plugs and Conversion Adaptors for Domestic Use) Regulations 1997.</p>		N/A
3.2.4	<p>In Switzerland, for requirements see 3.2.1.1 of this annex.</p>		N/A
3.2.5.1	<p>In the United Kingdom, a power supply cord with conductor of 1,25 mm² is allowed for equipment with a rated current over 10 A and up to and including 13 A.</p>		N/A

Disclaimer: This document is controlled and has been released electronically.
Only the version on the IECEE Website is the current document version

IEC60950_1F - ATTACHMENT			
Clause	Requirement + Test	Result - Remark	Verdict
ZB ANNEX (NORMATIVE) SPECIAL NATIONAL CONDITIONS (EN)			
Clause	Requirement + Test	Result - Remark	Verdict
3.3.4	In the United Kingdom , the range of conductor sizes of flexible cords to be accepted by terminals for equipment with a RATED CURRENT of over 10 A up to and including 13 A is: • 1,25 mm ² to 1,5 mm ² nominal cross-sectional area.		N/A
4.3.6	In the United Kingdom , the torque test is performed using a socket outlet complying with BS 1363 part 1:1995, including Amendment 1:1997 and Amendment 2:2003 and the plug part of DIRECT PLUG-IN EQUIPMENT shall be assessed to BS 1363: Part 1, 12.1, 12.2, 12.3, 12.9, 12.11, 12.12, 12.13, 12.16 and 12.17, except that the test of 12.17 is performed at not less than 125 °C. Where the metal earth pin is replaced by an Insulated Shutter Opening Device (ISOD), the requirements of clauses 22.2 and 23 also apply.		N/A
4.3.6	In Ireland , DIRECT PLUG-IN EQUIPMENT is known as plug similar devices. Such devices shall comply with Statutory Instrument 526:1997 - National Standards Authority of Ireland (Section 28) (Electrical plugs, plug similar devices and sockets for domestic use) Regulations, 1997.		N/A
5.1.7.1	In Finland, Norway and Sweden TOUCH CURRENT measurement results exceeding 3,5 mA r.m.s. are permitted only for the following equipment: • STATIONARY PLUGGABLE EQUIPMENT TYPE A that is intended to be used in a RESTRICTED ACCESS LOCATION where equipotential bonding has been applied, for example, in a telecommunication centre; and has provision for a permanently connected PROTECTIVE EARTHING CONDUCTOR; and is provided with instructions for the installation of that conductor by a SERVICE PERSON; • STATIONARY PLUGGABLE EQUIPMENT TYPE B; • STATIONARY PERMANENTLY CONNECTED EQUIPMENT.		N/A

IEC60950_1F - ATTACHMENT			
Clause	Requirement + Test	Result - Remark	Verdict

ZB ANNEX (NORMATIVE) SPECIAL NATIONAL CONDITIONS (EN)			
Clause	Requirement + Test	Result - Remark	Verdict
6.1.2.1 (A1:2010)	<p>In Finland, Norway and Sweden, add the following text between the first and second paragraph of the compliance clause:</p> <p>If this insulation is solid, including insulation forming part of a component, it shall at least consist of either</p> <ul style="list-style-type: none"> - two layers of thin sheet material, each of which shall pass the electric strength test below, or - one layer having a distance through insulation of at least 0,4 mm, which shall pass the electric strength test below. <p>Alternatively for components, there is no distance through insulation requirements for the insulation consisting of an insulating compound completely filling the casing, so that CLEARANCES and CREEPAGE DISTANCES do not exist, if the component passes the electric strength test in accordance with the compliance clause below and in addition</p> <ul style="list-style-type: none"> - passes the tests and inspection criteria of 2.10.11 with an electric strength test of 1,5 kV multiplied by 1,6 (the electric strength test of 2.10.10 shall be performed using 1,5 kV), and - is subject to ROUTINE TESTING for electric strength during manufacturing, using a test voltage of 1,5 kV. 		N/A

IEC60950_1F - ATTACHMENT			
Clause	Requirement + Test	Result - Remark	Verdict

ZB ANNEX (NORMATIVE) SPECIAL NATIONAL CONDITIONS (EN)			
Clause	Requirement + Test	Result - Remark	Verdict
	<p>It is permitted to bridge this insulation with an optocoupler complying with 2.10.5.4 b).</p> <p>It is permitted to bridge this insulation with a capacitor complying with EN 60384-14:2005, subclass Y2.</p> <p>A capacitor classified Y3 according to EN 60384-14:2005, may bridge this insulation under the following conditions:</p> <ul style="list-style-type: none"> - the insulation requirements are satisfied by having a capacitor classified Y3 as defined by EN 60384-14, which in addition to the Y3 testing, is tested with an impulse test of 2,5 kV defined in EN 60950-1:2006, 6.2.2.1; - the additional testing shall be performed on all the test specimens as described in EN 60384-14: - the impulse test of 2,5 kV is to be performed before the endurance test in EN 60384-14, in the sequence of tests as described in EN 60384-14. 		N/A
6.1.2.2	In Finland, Norway and Sweden , the exclusions are applicable for PERMANENTLY CONNECTED EQUIPMENT, PLUGGABLE EQUIPMENT TYPE B and equipment intended to be used in a RESTRICTED ACCESS LOCATION where equipotential bonding has been applied, e.g. in a telecommunication centre, and which has provision for a permanently connected PROTECTIVE EARTHING CONDUCTOR and is provided with instructions for the installation of that conductor by a SERVICE PERSON.		N/A
7.2	In Finland, Norway and Sweden , for requirements see 6.1.2.1 and 6.1.2.2 of this annex. The term TELECOMMUNICATION NETWORK in 6.1.2 being replaced by the term CABLE DISTRIBUTION SYSTEM.		N/A
7.3 (A11:2009)	In Norway and Sweden , for requirements see 1.2.13.14 and 1.7.2.1 of this annex.		N/A

IEC60950_1F - ATTACHMENT			
Clause	Requirement + Test	Result - Remark	Verdict

**Annex ZD
(informative)**

IEC and CENELEC code designations for flexible cords

Type of flexible cord	Code designations	
	IEC	CENELEC
PVC insulated cords		
Flat twin tinsel cord	60227 IEC 41	H03VH-Y
Light polyvinyl chloride sheathed flexible cord	60227 IEC 52	H03VV-F H03VVH2-F
Ordinary polyvinyl chloride sheathed flexible cord	60277 IEC 53	H05VV-F H05VVH2-F
Rubber insulated cords		
Braided cord	60245 IEC 51	H03RT-F
Ordinary tough rubber sheathed flexible cord	60245 IEC 53	H05RR-F
Ordinary polychloroprene sheathed flexible cord	60245 IEC 57	H05RN-F
Heavy polychloroprene sheathed flexible cord	60245 IEC 66	H07RN-F
Cords having high flexibility		
Rubber insulated and sheathed cord	60245 IEC 86	H03RR-H
Rubber insulated, crosslinked PVC sheathed cord	60245 IEC 87	H03RV4-H
Crosslinked PVC insulated and sheathed cord	60245 IEC 88	H03V4V4-H

IEC60950_1F - ATTACHMENT			
Clause	Requirement + Test	Result - Remark	Verdict
IEC60950_1F ATTACHMENT			
ATTACHMENT TO TEST REPORT IEC 60950-1 with A1: 2009 and A2:2013 JAPAN NATIONAL DIFFERENCES Information technology equipment – Safety – Part 1: General requirements			
Differences according to..... : J60950-1 (H29)			
Attachment Form No..... : JP_ND_IEC60950_1F			
Attachment Originator : JQA			
Master Attachment..... : 2017-11			
Copyright © 2017 IEC System for Conformity Testing and Certification of Electrical Equipment (IECEE), Geneva, Switzerland. All rights reserved.			
	National Differences		
1.2.4.1	Add the following new notes. Note: Even if the equipment is designed as Class I, the equipment is regarded as CLASS 0I EQUIPMENT (see 1.2.4.3A) when 2-pin adaptor with earthing lead wire or cord set having 2-pin plug with earthing lead wire is provided or recommended.		N/A

IEC60950_1F - ATTACHMENT			
Clause	Requirement + Test	Result - Remark	Verdict
1.2.4.3A	<p>Add the following new clause.</p> <p>1.2.4.3A CLASS 0I EQUIPMENT Equipment having attachment plug without earthing blade, where protection against electric shock is achieved by:</p> <ul style="list-style-type: none"> - using BASIC INSULATION, and - providing either of the following a) or b) in order to connect those conductive parts that might assume a HAZARDOUS VOLTAGES in the event of BASIC INSULATION fault to the PROTECTIVE EARTHING CONDUCTOR in the building wiring. <p>a) Provision of 2-pin plug with earthing lead including the condition of that 2-pin adaptor with earthing lead wire is provided or recommended.</p> <p>b) Provision of an independent earthing terminal, when 2-core mains cord (without earthing conductor) is used.</p> <p>Note – CLASS 0I EQUIPMENT may have a part constructed with Double Insulation or Reinforced Insulation.</p>		N/A
1.3.2	<p>Add the following notes after the first paragraph:</p> <p>Note 1 Transportable or similar equipment that are relocated frequently for intended usage should not be designed as Class I or CLASS 0I EQUIPMENT unless it is intended to be installed by service personnel.</p> <p>Note 2 Considering wiring circumstance in Japan, equipment intended to be installed where the provision for earthing connection is unlikely should not be designed as Class I or CLASS 0I EQUIPMENT unless it is intended to be installed by service personnel.</p>		N/A

IEC60950_1F - ATTACHMENT			
Clause	Requirement + Test	Result - Remark	Verdict
1.5.1	<p>Replace the first paragraph with the follows:</p> <p>Where safety is involved, components shall comply either with the requirements of this standard, with the safety aspects of the relevant JIS component standard, or IEC component standards, or components shall have equivalent to or better properties than these.</p> <p>Replace Note 1 with the following:</p> <p>Note 1 Components complying with the interpretation of Ministerial Ordinance on stipulating technical requirements for the Electrical Appliance is regarded to have equivalent to or better performance.</p> <p>Note 2 JIS or an IEC component standard is considered relevant only if the component in question clearly falls within its scope.</p> <p>Add the following after the last paragraph:</p> <p>For an appliance connector that is able to fit with appliance inlet compatible with the standard sheet of IEC 60320-1 or JIS C 8283-1, the size of the connector shall comply with relevant standard sheet of IEC 60320-1 or JIS C 8283-1. A power supply cord set complying with JIS C 8286 is regarded to comply with this requirement.</p> <p>Note 3 A power supply cord set provided with appliance connector that is able to fit with appliance inlet compatible with the standard sheet of IEC 60320-1 or JIS C 8283-1 should comply with JIS C 8286.</p>	<p>All components identified are either complied with IEC standards or relevant requirements of JIS component standards. (See appended Table 1.5.1).</p>	P
1.5.2	<p>Add the following Note 2 after the 4th dashed paragraph:</p> <p>Note 2 See 1.7.5A when Type C.14 appliance coupler rated 10 A per JIS C 8283-1 is used with an equipment rated not more than 125 V and rated more than 10 A.</p>		N/A
1.5.5	<p>Add the following Note after the last paragraph:</p> <p>NOTE An interconnection cord sets provided with interconnecting coupler for mains supply complying with JIS C 8283-2-2 should comply with JIS C 8286.</p>		N/A

IEC60950_1F - ATTACHMENT			
Clause	Requirement + Test	Result - Remark	Verdict
1.5.9.1	Add the following in the last of NOTE 1. Gas discharge tube connected in series with VDR may be used.		N/A
1.7	Replace EE.2 and EE.4 with the following: JA.1 Shredder warning JA.3 Shredder power disconnection		N/A
1.7.1.2	Replace first and second dashed paragraphs with the followings: - manufacturer's or responsible company's name or trade-mark or identification mark; - manufacturer's or responsible company's model identification or type reference;	See Copy of marking plate.	P
1.7.2.1	Add the following after the second paragraph. Instruction or equipment marking regarding safety shall be written in Japanese unless otherwise permitted in this standard.	When the equipment marketed to Japan, the instruction or marking will be described in Japanese.	N/A
1.7.2.5	Replace the last sentence with the following: An acceptable marking for an electric shock hazard is  (6.2.4 of JIS S 0101).		N/A
1.7.5	Replace the second paragraph with the following. Socket-outlets conforming to JISC8282-1 are examples of standard power supply outlets.		N/A

IEC60950_1F - ATTACHMENT			
Clause	Requirement + Test	Result - Remark	Verdict
1.7.5A	<p>Add the following new clause after 1.7.5.</p> <p>1.7.5A Power supply cord set If appliance coupler according to IEC60320-1, C.14(rated current: 10A) is used in equipment whose rated voltage is less than 125V and rated current is over 10A, the following instruction or equivalent shall be described in the operating instruction. “ Use only designated cord set attached in this equipment”</p> <p><i>Example in Japanese:</i> “この機器に同こん(梱)した指定の電源コードセットだけを使用して下さい。”</p> <p>If appliance coupler is used for connection to the mains and if the cord set is not provided within the package for the equipment, suitable information regarding to the cord set shall be described in the operating instruction</p> <p>Note Since the combination of appliance inlet with earthing pin and two-core cord set (without earthing conductor) is special, the cord set should be attached in the equipment and the operating <i>instruction should provide the information that the cord set is exclusively used with the equipment and not allowed to use with other equipment.</i></p>		N/A

IEC60950_1F - ATTACHMENT			
Clause	Requirement + Test	Result - Remark	Verdict
1.7.14A	<p>Add the following new clause after 1.7.14.</p> <p>1.7.14A Marking for CLASS 0I EQUIPMENT For CLASS 0I EQUIPMENT, the following or equivalent instructions shall be marked.</p> <p>- the following instruction shall be marked on the mains plug or on the visible place of the main body</p> <p>“Provide an earthing connection”</p> <p><i>Example in Japanese:</i> “必ず接地接続を行ってください。”</p> <p>- the following instruction shall be marked on the visible place of the main body or written in the operating instructions:</p> <p>“Provide an earthing connection before the mains plug is connected to the mains. And, when disconnecting the earthing connection, be sure to disconnect after pulling out the mains plug from the mains.”</p> <p><i>Example in Japanese:</i> 接地接続は必ず、電源プラグを電源につなぐ前に行ってください。 また、接地接続を外す場合は、必ず電源プラグを電源から切り離してから行ってください。</p>		N/A
1.7.14B	<p>Add the following new clause after 1.7.14A</p> <p>1.7.14B Protective earthing conductor used for CLASS 0I EQUIPMENT</p> <p>For CLASS 0I EQUIPMENT provided with independent main protective earthing terminal, where the cord for the protective earthing connection is not provided within the package for the equipment, the suitable information for the protective earthing connection shall be provided in the operating instruction. (See 2.6.3.2)</p>		N/A

IEC60950_1F - ATTACHMENT			
Clause	Requirement + Test	Result - Remark	Verdict
2.1.1.1	<p>Replace item b) of 2.1.1.1 with the following.</p> <p>b) A test with the test finger, Figure 2A, which shall not contact parts described above when applied to openings in the ENCLOSURES after removal of parts that can be detached by an OPERATOR, including fuseholders, and with OPERATOR access doors and covers open. It is permitted to leave lamps in place for this test. Connectors that can be separated by an OPERATOR, other than those complying with JIS C 8303 or JIS C 8285 or IEC 60309 series or JIS C 8283 series or IEC 60320 series, shall also be tested during disconnection. But even if the connector does not comply with these standards, the one having equivalent to or better performance need not be tested during disconnection.</p> <p>Note 4 Connectors complying with Appendix 4 of the interpretation of Ministerial Ordinance on stipulating technical requirements for the Electrical Appliance is regarded to have equivalent to or better performance.</p>		P
2.5	Replace "IEC 60730-1" with "JIS C 9730-1" (in item b)).		N/A
2.6.2	<p>Delete the following line.</p> <p>• the symbol , IEC 60417-5018 (2011-07);</p>		N/A
2.6.3.2	<p>Add the following after the first paragraph.</p> <p>However where the single core conductor is used for protective earthing lead or earthing cord for CLASS 0I EQUIPMENT, either of the following condition shall be met.</p> <ul style="list-style-type: none"> - Use of annealed copper wire with 1.6 mm diameter or corrosion-inhibiting metal wire having equivalent to or more strength and thickness. - Single core cord or single core cable with 1.25 mm² or more cross-sectional area 		N/A

IEC60950_1F - ATTACHMENT			
Clause	Requirement + Test	Result - Remark	Verdict
2.6.3.5	<p>Add the following after the first paragraph.</p> <p>However this requirement does not apply to internal conductor of the cord set that is covered by the sheath of mains cord and is formed together with mains plug and appliance connector.</p>		N/A
2.6.4.2	<p>Replace the first paragraph with the following.</p> <p>Equipment required to have protective earthing shall have a main protective earthing terminal. For equipment with a DETACHABLE POWER SUPPLY CORD, the earthing terminal in the appliance inlet is regarded as the main protective earthing terminal. However, for CLASS 0I EQUIPMENT provided with the separate main protective earthing terminal other than appliance inlet, the separate main protective earthing terminal may be treated as mains protective earthing terminal.</p>		N/A
2.6.5.4	<p>Replace the first sentence with the following.</p> <p>Protective earthing connections of CLASS I EQUIPMENT shall make earlier and break later than the supply connections in each of the following:</p> <p>Add the following after last paragraph:</p> <p>Note For CLASS 0I EQUIPMENT, 1.7.14A is applied instead of this requirement.</p>		N/A
2.6.5.8A	<p>Add the following new clause after 2.6.5.8</p> <p>2.6.5.8A Earthing of CLASS 0I EQUIPMENT Plugs with a lead wire for earthing shall not be used for equipment having a rated voltage exceeding 150V. For plugs with a lead wire for earthing, the lead wire shall not be earthed by a clip. CLASS 0I EQUIPMENT shall be provided with an earthing terminal or lead wire for earthing in the external location where easily visible.</p>		N/A
2.7.6	<p>Replace "ISO 3864, No. 5036" with "6.2.4 of JIS S 0101".</p>		N/A

IEC60950_1F - ATTACHMENT			
Clause	Requirement + Test	Result - Remark	Verdict
2.10.3.1	<p>Replace the 8th paragraph with the following</p> <p>The above minimum CLEARANCE for connectors do not apply to connectors that comply with JIS C 8285, IEC60309 series of standards, JIS C 8283 series of standards, IEC60320 series of standards, JIS C 8303, or even if it does not comply with the above standards but the one having equivalent to or better performance and dimension which comply with JIS C 8283 series of standards, JIS C 8303 or IEC 60309-2. Note Connectors complying with Appendix 4 of the interpretation of Ministerial Ordinance on stipulating technical requirements for the Electrical Appliance is regarded to have equivalent to or better performance.</p>		N/A
2.10.3.2 Table 2J	In Japan, the value of the main power supply transient voltage for the nominal ac main power supply voltage of 100 V is determined by applying the row of AC main power supply voltage 150 V.		N/A
2.10.4.3	<p>Replace the 6th paragraph with the following</p> <p>The above minimum CREEPAGE DISTANCE for connectors do not apply to connectors that comply with JIS C 8285, IEC60309 series of standards, JIS C 8283 series of standards, IEC60320 series of standards, JIS C 8303, or even if it does not comply with the above standards but the one having equivalent to or better performance and dimension which comply with JIS C 8283 series of standards, JIS C 8303 or IEC 60309-2. Note Connectors complying with Appendix 4 of the interpretation of Ministerial Ordinance on stipulating technical requirements for the Electrical Appliance is regarded to have equivalent to or better performance.</p>		N/A
2.10.9	Replace "1.4.5" in the third paragraph with "1.4.12".		N/A
3.2.3	<p>Add the following after the third paragraph.</p> <p>Table 3A applies when cables complying JIS C 3662 series of standards or JIS C 3663 series of standards are used. In case of other cables, cable entries shall be so designed that the cable could be fitted in a conduit.</p>		N/A

IEC60950_1F - ATTACHMENT			
Clause	Requirement + Test	Result - Remark	Verdict
3.2.4	<p>Add the following as 4th dashed paragraph.</p> <p>- be so constructed that mechanical stress shall not transmit to the soldering part of inlet terminal during insertion or removal of the connector except that the body of the inlet is secured and is secured not only soldering.</p>		N/A
3.2.5.1	<p>Add the following after Note 3:</p> <p>Note 4 In Japan, mains cords having equivalent to or better electro-mechanical and fire safety performance as above and complying with Appendix 1 of the interpretation of Ministerial Ordinance on stipulating technical requirements for the Electrical Appliance can be used.</p> <p>Replace the paragraph after Note 3 with the following.</p> <p>For equipment required to have protective earthing, a PROTECTIVE EARTHING CONDUCTOR shall be included in the MAINS SUPPLY cord except for CLASS 0I EQUIPMENT having separate protective earthing conductor from mains cord.</p> <p>Add the following after the second paragraph after Note 3:</p> <p>Note 5 For the cross-sectional area of mains cord described in Note 4, relevant Japanese wiring regulation can be applied.</p>		N/A
3.2.5A	<p>Add the following new clause after 3.2.5</p> <p>3.2.5A AC mains plug Mains plug for PLUGGABLE EQUIPMENT TYPE A shall comply with JIS C 8282-1 or equivalent to or better performance. Power supply cord set complying with JIS C 8286 is regarded to meet the requirements. Mains plug with fuse link for PLUGGABLE EQUIPMENT TYPE A shall comply with JIS C 8282-2-1 or equivalent to or better performance.</p> <p>Note Mains plug complying with Appendix 4 of the interpretation of Ministerial Ordinance on stipulating technical requirements for the Electrical Appliance is regarded to have equivalent to or better performance.</p>		N/A

IEC60950_1F - ATTACHMENT			
Clause	Requirement + Test	Result - Remark	Verdict
3.3.4 Table 3D	<p>Add the following note to Table 3D:</p> <p>Note For cables other than those complying with JIS C 3662 series of standards or JIS C 3663 series of standards, the terminals shall be suitable for the size of the intended cables.</p>		N/A
3.3.7	<p>Add the following after the first sentence:</p> <p>This requirement is not applicable to the external earthing terminal of CLASS 0I EQUIPMENT.</p>		N/A
4.2.8	<p>Add the following after the first paragraph:</p> <p>Note Intrinsically protected picture tube is required to comply with JIS C 6965 in clause 18 of JIS C 6065. No intrinsically protected picture tube which is out of scope of JIS C 6965 is required to test according to sub-clause 18.2 of JIS C 6065.</p>		N/A
4.3.4	<p>Add the following after the first sentence:</p> <p>This requirement also applies to those connections in CLASS 0I EQUIPMENT, where CLEARANCE or CREEPAGE DISTANCES over BASIC INSULATION would be reduced to less than the values specified in 2.10.</p>		N/A
4.3.5	<p>Replace the first dashed paragraph with the following.</p> <p>Within a manufacturer's unit or system, plugs and sockets likely to be used by the OPERATOR or by a SERVICE PERSON shall not be employed in a manner likely to create a hazard due to misconnection. In particular, connectors complying with IEC 60320/JIS C 8283 series of standards or JIS C 8303 or JIS C 8358 shall not be used for SELV CIRCUITS or TNV CIRCUITS. Keying, location or, in the case of connectors accessible only to a SERVICE PERSON, clear markings are permitted to meet the requirement.</p>		N/A
4.3.6	<p>Replace the 1st paragraph with the following</p> <p>DIRECT PLUG-IN EQUIPMENT shall not impose undue stress on the socket-outlet. The mains plug part shall comply with the standard for the relevant mains plug. (see 3.2.5A)</p>		N/A

IEC60950_1F - ATTACHMENT			
Clause	Requirement + Test	Result - Remark	Verdict
4.4.2	<p>Replace the paragraph with the following:</p> <p>HOUSEHOLD AND HOME/OFFICE DOCUMENT/MEDIA SHREDDERS shall also comply with Annex JA.</p>		N/A
4.5.3	<p>Add the following note to footnote b) of Table 4B:</p> <p>NOTE In case no data for the material is available, Appendix 4, 1. (1). b. 3 of the Interpretation on the Ministerial Ordinance stipulating Technical Specifications for Electrical Appliances is regarded as maximum temperature limit of the material.</p>	Added.	P
5.1.3	<p>Add a note after the first paragraph as follows:</p> <p>Note – Attention should be drawn to that majority of three-phase power system in Japan is of delta connection, and therefore, in that case, test is conducted using the test circuit from IEC 60990, figure 13.</p>		N/A

IEC60950_1F - ATTACHMENT																																							
Clause	Requirement + Test	Result - Remark	Verdict																																				
5.1.6	<p>Replace Table 5A. as follows</p> <table border="1"> <thead> <tr> <th>Type of equipment</th> <th>Terminal A of measuring instrument connected to:</th> <th>Maximum TOUCH CURRENT mA r.m.s. ^a</th> <th>Maximum PROTECTIVE CONDUCTOR CURRENT</th> </tr> </thead> <tbody> <tr> <td>ALL equipment</td> <td>Accessible parts and circuits not connected to protective earth ^b</td> <td>0,25</td> <td>-</td> </tr> <tr> <td rowspan="2">HAND-HELD</td> <td>Main protective earthing terminal of CLASS I EQUIPMENT</td> <td>0,75</td> <td>-</td> </tr> <tr> <td>Main protective earthing terminal of CLASS 0 I EQUIPMENT</td> <td>0,5</td> <td>-</td> </tr> <tr> <td rowspan="2">MOVABLE (other than HAND_HELD, but including TRANSPORTABLE EQUIPMENT)</td> <td>Main protective earthing terminal of CLASS I EQUIPMENT</td> <td>3,5</td> <td>-</td> </tr> <tr> <td>Main protective earthing terminal of CLASS 0 I EQUIPMENT</td> <td>1,0</td> <td>-</td> </tr> <tr> <td rowspan="2">STATIONARY, PLUGGABLE TYPE A</td> <td>Main protective earthing terminal of CLASS I EQUIPMENT</td> <td>3,5</td> <td>-</td> </tr> <tr> <td>Main protective earthing terminal of CLASS 0 I EQUIPMENT</td> <td>1,0</td> <td>-</td> </tr> <tr> <td rowspan="2">ALL other STATIONARY EQUIPMENT - not subject to the conditions of 5.1.7 - subject to the conditions of 5.1.7</td> <td>Main protective earthing terminal of CLASS I EQUIPMENT</td> <td>3,5 -</td> <td>- 5 % of input current</td> </tr> <tr> <td>Main protective earthing terminal of CLASS 0 I EQUIPMENT</td> <td>1,0 -</td> <td>- -</td> </tr> </tbody> </table> <p>a If peak values of TOUCH CURRENT are measured, the maximum values are obtained by multiplying the r.m.s.values in the table by 1,414. b Some unearthed accessible parts are covered in 1.5.6 and 1.5.7 and the requirements of 2.4 apply. These may be different from those in 5.1.6.</p>	Type of equipment	Terminal A of measuring instrument connected to:	Maximum TOUCH CURRENT mA r.m.s. ^a	Maximum PROTECTIVE CONDUCTOR CURRENT	ALL equipment	Accessible parts and circuits not connected to protective earth ^b	0,25	-	HAND-HELD	Main protective earthing terminal of CLASS I EQUIPMENT	0,75	-	Main protective earthing terminal of CLASS 0 I EQUIPMENT	0,5	-	MOVABLE (other than HAND_HELD, but including TRANSPORTABLE EQUIPMENT)	Main protective earthing terminal of CLASS I EQUIPMENT	3,5	-	Main protective earthing terminal of CLASS 0 I EQUIPMENT	1,0	-	STATIONARY, PLUGGABLE TYPE A	Main protective earthing terminal of CLASS I EQUIPMENT	3,5	-	Main protective earthing terminal of CLASS 0 I EQUIPMENT	1,0	-	ALL other STATIONARY EQUIPMENT - not subject to the conditions of 5.1.7 - subject to the conditions of 5.1.7	Main protective earthing terminal of CLASS I EQUIPMENT	3,5 -	- 5 % of input current	Main protective earthing terminal of CLASS 0 I EQUIPMENT	1,0 -	- -		
Type of equipment	Terminal A of measuring instrument connected to:	Maximum TOUCH CURRENT mA r.m.s. ^a	Maximum PROTECTIVE CONDUCTOR CURRENT																																				
ALL equipment	Accessible parts and circuits not connected to protective earth ^b	0,25	-																																				
HAND-HELD	Main protective earthing terminal of CLASS I EQUIPMENT	0,75	-																																				
	Main protective earthing terminal of CLASS 0 I EQUIPMENT	0,5	-																																				
MOVABLE (other than HAND_HELD, but including TRANSPORTABLE EQUIPMENT)	Main protective earthing terminal of CLASS I EQUIPMENT	3,5	-																																				
	Main protective earthing terminal of CLASS 0 I EQUIPMENT	1,0	-																																				
STATIONARY, PLUGGABLE TYPE A	Main protective earthing terminal of CLASS I EQUIPMENT	3,5	-																																				
	Main protective earthing terminal of CLASS 0 I EQUIPMENT	1,0	-																																				
ALL other STATIONARY EQUIPMENT - not subject to the conditions of 5.1.7 - subject to the conditions of 5.1.7	Main protective earthing terminal of CLASS I EQUIPMENT	3,5 -	- 5 % of input current																																				
	Main protective earthing terminal of CLASS 0 I EQUIPMENT	1,0 -	- -																																				
Annex G	<p>Replace the paragraph before Table G.2 with the following</p> <p>The above minimum CLEARANCE for connectors do not apply to connectors that comply with JIS C 8285, IEC60309 series of standards, JIS C 8283 series of standards, IEC60320 series of standards, JIS C 8303, and 1.5.1 of this standard in which dimension is comply with JIS C 8283 series, JIS C 8303 or IEC 60309-2.</p>		N/A																																				
Annex V V.1	<p>Replace "3.1.2" in the first line of V.1 with "312" in the first line.</p>		N/A																																				

IEC60950_1F - ATTACHMENT			
Clause	Requirement + Test	Result - Remark	Verdict
Annex W W.1	<p>Replace the third sentence in the first paragraph with the following:</p> <p>Floating circuits can exist in CLASS I EQUIPMENT, CLASS 0I EQUIPMENT and earthed circuits can exist in CLASS II EQUIPMENT.</p>		N/A
Annex BB	This annex is not applicable.		N/A
Annex CC CC.2	<p>Replace the third dashed paragraph with the following:</p> <p><i>- 10 000 cycles of turning enable on and off with the input connected to a capacitor rated 425 uF ± 10 uF and shorting the output;</i></p>		N/A
CC.3	<p>Add note at end of CC.3:</p> <p>Note: The fast blow fuse should be the one complying with JIS C 6575-2.</p>		N/A

IEC60950_1F - ATTACHMENT			
Clause	Requirement + Test	Result - Remark	Verdict
CC.4	<p>Replace the 2nd dashed paragraph with the following:</p> <ul style="list-style-type: none"> - 10 000 cycles of turning enable on and off with a $100 \Omega \pm 5 \Omega$ resistor and a $425 \mu\text{F} \pm 10 \mu\text{F}$ capacitor in parallel with the output; <p>Replace the 4th dashed paragraph with the following:</p> <ul style="list-style-type: none"> - 10 000 cycles of turning enable on and off with the input connected to a capacitor rated $425 \mu\text{F} \pm 10 \mu\text{F}$ and shorting the output; <p>Replace the 5th dashed paragraph with the following:</p> <ul style="list-style-type: none"> -10 000 cycles of turning the input pin on and off with a capacitor rated $425 \mu\text{F} \pm 10 \mu\text{F}$ connected to the input supply while keeping enable active and shorting the output; <p>Replace the 6th dashed paragraph with the following:</p> <ul style="list-style-type: none"> -10 000 cycles of turning the input pin on and off with an ferrite-core inductor having $350 \text{ mH} \pm 10 \text{ mH}$ inductance at 1 kHz and less than 1Ω d.c. resistance connected to the input supply and return while keeping enable active and shorting the output; <p>Replace the 10th dashed paragraph with the following:</p> <ul style="list-style-type: none"> -3 cycles of exposing the device (not energized) to $70 \text{ }^\circ\text{C} \pm 2 \text{ }^\circ\text{C}$ for 24 h; followed by at least 1 h at room ambient; followed by at least 3 h at $-30 \text{ }^\circ\text{C} \pm 2 \text{ }^\circ\text{C}$; followed by 3 h at room ambient; <p>Replace the 11th dashed paragraph with the following:</p> <ul style="list-style-type: none"> -10 cycles of exposing the device (while energized) to $50 \text{ }^\circ\text{C} \pm 2 \text{ }^\circ\text{C}$ for 10 min; followed by 10 min at $0 \text{ }^\circ\text{C} \pm 2 \text{ }^\circ\text{C}$ with a 5 min period of transition from one state to the other; 		N/A

IEC60950_1F - ATTACHMENT			
Clause	Requirement + Test	Result - Remark	Verdict
Annex EE	<p>Replace Annex EE with the following Annex JA.</p> <p style="text-align: center;">Annex JA (normative) Document shredding machines</p> <p>HOUSEHOLD AND HOME/OFFICE DOCUMENT/MEDIA SHREDDERS shall additionally comply with the requirements of this annex.</p> <p>JA.1 Markings and instructions</p> <p>The symbol  (JIS S 0101:2000, 6.2.1) and the following precautions for use shall be marked on readily visible part adjacent to document feed opening. The marking shall be clearly legible, permanent, and easily discernible;</p> <p>子供が使用することによって、傷害などの危害が発生するおそれがある。; (that use by infants/children may cause a hazard of injury etc.)</p> <p>文書投入口に手を触れることによって、細断機構に引き込まれるおそれがある。; (that a hand can be drawn into the mechanical section for shredding when touching the document-slot)</p> <p>文書投入口に衣類が触れることによって、細断機構に引き込まれるおそれがある。; (that clothing can be drawn into the mechanical section for shredding when touching the document-slot)</p> <p>文書投入口に髪の毛が触れることによって、細断機構に引き込まれるおそれがある。; (that hairs can be drawn into the mechanical section for shredding when touching the document-slot)</p> <p>- in case of equipment incorporating a commutator motor, 可燃性ガスを噴射することによって引火又は爆発するおそれがある。 (that equipment may catch fire or explode by spraying of flammable gas.)</p> <p>JA.2 Inadvertent reactivation</p> <p>Any safety interlock that can be operated by means of the test finger, Figure JA.1, is considered to be likely to cause inadvertent reactivation of the hazard.</p> <p>Compliance is checked by inspection and, where necessary, by a test with the test finger, Figure JA.1.</p>		N/A

IEC60950_1F - ATTACHMENT			
Clause	Requirement + Test	Result - Remark	Verdict
	<p>JA.3 Disconnection from the mains supply</p> <p>Document shredding machines shall incorporate an isolating switch complying with sub-clause 3.4.2 as the device disconnecting the power of hazardous moving parts. For this switch, two-position (single-use) switch or multi-position (multifunction) switch (e.g., slide switch) may be used.</p> <p>If two-position switch, the positions for “ON” and “OFF” shall be indicated in accordance with sub-clause 1.7.8. If multi-position switch, the position for “OFF” shall be indicated in accordance with sub-clause 1.7.8 and other positions shall be indicated with proper terms or symbols.</p> <p>Compliance is checked by inspection.</p> <p>JA.4 Protection against hazardous moving parts</p> <p>Any warning shall not be used instead of the structure for preventing access to hazardous moving parts.</p> <p>Document shredding machines shall comply with the following requirements.</p> <p>Insert the test finger, Figure JA.1, into all openings in MECHANICAL ENCLOSURES without applying appreciable force. It shall not be possible to touch hazardous moving parts with the test finger. This consideration applies to all sides of MECHANICAL ENCLOSURES when the equipment is mounted as intended. Before testing with the test finger, remove the parts detachable without a tool.</p> <p>Insert the wedge-probe, Figure JA.2, into the document-slot. And, against all directions of openings, if straight-cutting type, a force of 45 N shall apply to the probe, and 90 N if cross-cutting type. In this case, the weight of the probe is to be factored into the overall applied force. Before testing with the wedge-probe, remove the parts detachable without a tool. It shall not be possible to touch any hazardous moving parts, including the shredding roller or the mechanical section for shedding, with the probe.</p>		

IEC60950_1F - ATTACHMENT			
Clause	Requirement + Test	Result - Remark	Verdict

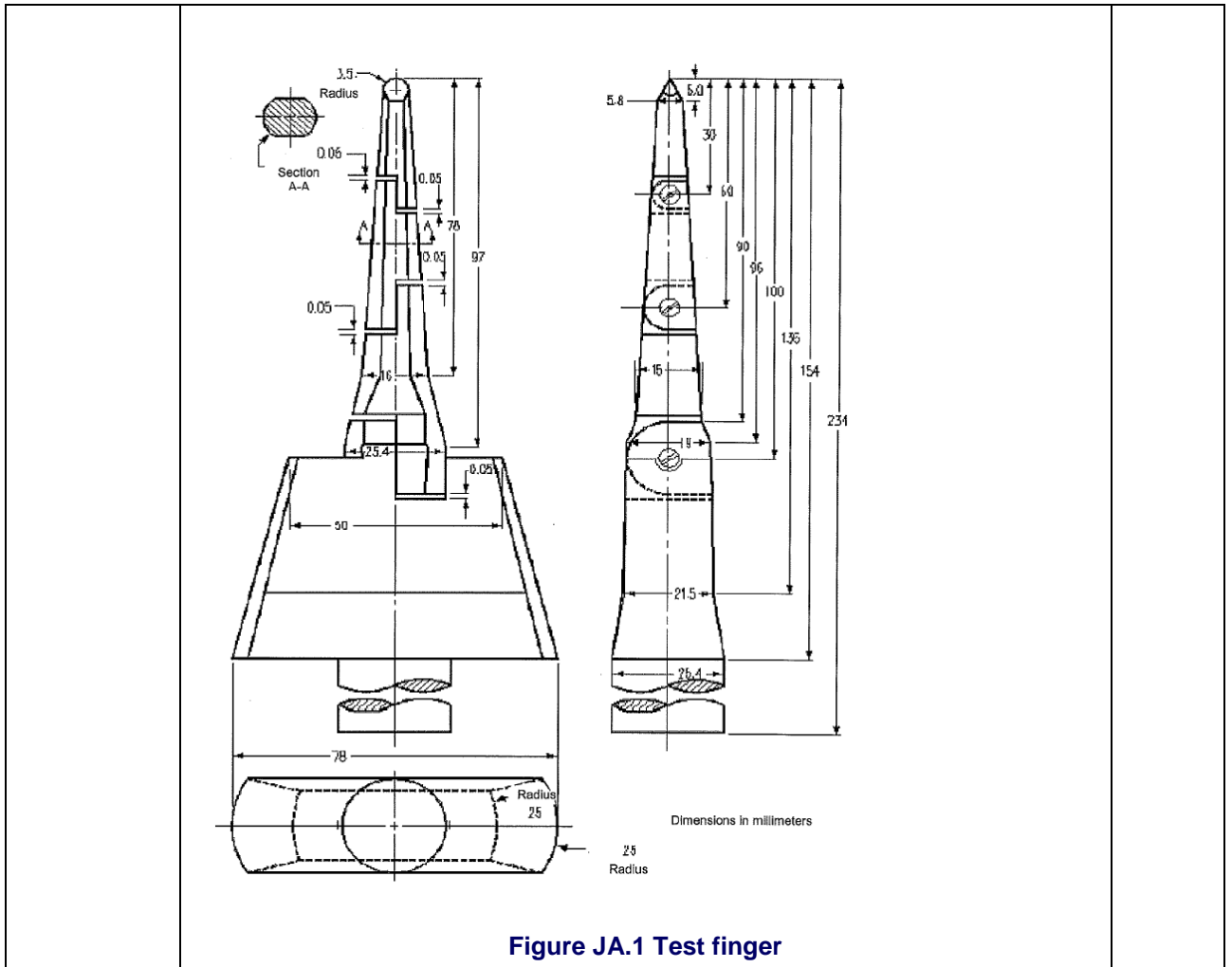

IEC60950_1F - ATTACHMENT

Clause	Requirement + Test	Result - Remark	Verdict
--------	--------------------	-----------------	---------

(Details of the tip of wedge)

Distance from the tip (mm)	Thickness of probe (mm)
0	2
12	4
180	24

Note 1 - The thickness of the probe varies linearly, with slope changes at the respective points shown in the table.
 Note 2 –The allowable dimensional tolerance of the probe is;
 for ≤ 25 mm: ± 0.13 mm
 for > 25 mm: ± 0.3 mm.

Figure JA.2 Wedge-probe

IEC60950_1F - ATTACHMENT			
Clause	Requirement + Test	Result - Remark	Verdict

IEC60950_1F ATTACHMENT			
Clause	Requirement + Test	Result - Remark	Verdict
ATTACHMENT TO TEST REPORT IEC 60950-1 (AUSTRALIA/NEW ZEALAND) NATIONAL DIFFERENCES (Information technology equipment-safety)			
Differences according to: AS/NZS 60950.1:2015			
Attachment Form No.: AU_NZ_ND_IEC60950_1F			
Attachment Originator: JAS-ANZ			
Master Attachment: 2017-06			
Copyright © 2017 IEC System for Conformity Testing and Certification of Electrical Equipment (IECEE), Geneva, Switzerland. All rights reserved.			

	National Differences		
Appendix ZZ	Variations to IEC 60950-1, Ed 2.2 (2013) for Australia and New Zealand		
1.2	DEFINITIONS		P
	After definition 'PERSON, SERVICE', insert the following new definition: POTENTIAL IGNITION SOURCE.....1.2.12.201	Considered.	P
1.5	COMPONENTS		P
1.5.1	1. First paragraph, insert the following text after the words 'IEC component standard': or the relevant Australian/New Zealand Standard 2. In the Note, insert the following text after the word standard: or the relevant Australian/New Zealand Standard 3. Second paragraph, delete the words 'without further evaluation'		P
1.5.2	1. First paragraph, insert the following text after the word 'standard' or an Australian/New Zealand Standard 2. First paragraph, second dash item, second line, insert the following text after the word 'standard' or an Australian/New Zealand Standard 3. First paragraph, second dash item, last line, insert the following text after the word 'standard': or an Australian/New Zealand Standard		P

IEC60950_1F - ATTACHMENT															
Clause	Requirement + Test	Result - Remark	Verdict												
1.7	MARKINGS AND INSTRUCTIONS		P												
1.7.1.3	<i>Delete</i> existing text and <i>replace</i> with the following: Graphical symbols placed on the equipment as a requirement of this standard, shall be in accordance with IEC 60417 or ISO 3864-2 or ISO 7000, if available. In the absence of suitable symbols, the manufacturer may design specific graphical symbols. Symbols as required by this standard placed on the equipment shall be explained in the user manual	See Copy of marking plate .	P												
2.9	ELECTRICAL INSULATION		N/A												
2.9.2	Variation Second paragraph, <i>delete</i> the word 'designated'	Deleted.	N/A												
3.2.5	POWER SUPPLY CORDS		N/A												
Table 3B	Variation 1. <i>Delete</i> the first four rows and replace with the following: <table border="1" data-bbox="416 1111 1031 1424"> <tbody> <tr> <td>Over 0.2 up to and including 3</td> <td>0.5^a</td> <td>18 [0.8]</td> </tr> <tr> <td>Over 3 up to and including 7.5</td> <td>0.75</td> <td>16 [1.3]</td> </tr> <tr> <td>Over 7.5 up to including 10</td> <td>(0.75)^b 1.00</td> <td>16 [1.3]</td> </tr> <tr> <td>Over 10 up to including 16</td> <td>(1.0)^c 1.5</td> <td>14 [2]</td> </tr> </tbody> </table>	Over 0.2 up to and including 3	0.5 ^a	18 [0.8]	Over 3 up to and including 7.5	0.75	16 [1.3]	Over 7.5 up to including 10	(0.75) ^b 1.00	16 [1.3]	Over 10 up to including 16	(1.0) ^c 1.5	14 [2]	Deleted.	N/A
Over 0.2 up to and including 3	0.5 ^a	18 [0.8]													
Over 3 up to and including 7.5	0.75	16 [1.3]													
Over 7.5 up to including 10	(0.75) ^b 1.00	16 [1.3]													
Over 10 up to including 16	(1.0) ^c 1.5	14 [2]													
	1. <i>Delete</i> NOTE 1 and renumber existing NOTE 2 as 'NOTE'	Deleted.	N/A												
	1. <i>Delete</i> Footnote ^a and replace with the following: ^a This nominal cross-sectional area is only allowed for Class II appliances if the length of the power supply cord, measured between the point where the cord, or cord guard, enters the appliance, and the to the plug does not exceed 2 m (0,5 mm ² three-core supply flexible cords are not permitted; see AS/NZS 3191)	Deleted.	N/A												
4.3	DESIGN AND CONSTRUCTION		N/A												
4.3.6	Variation <i>Delete</i> the third paragraph and <i>replace</i> with the following:	Deleted.	N/A												

IEC60950_1F - ATTACHMENT			
Clause	Requirement + Test	Result - Remark	Verdict
	<i>Equipment with a plug portion, suitable for insertion into a 10 A 3-pin flat-pin socket-outlet complying with AS/NZS 3112 shall comply with the requirements in AS/NZS 3112 for equipment with integral pins for insertion into socket-outlets</i>		N/A
4.3.8	Addition Eighth paragraph, <i>insert</i> the following new note after the first dash item:	Added.	N/A
	NOTE 6.201 In cases where the voltage source is provided by power from an unassociated power source, consideration should be given to the effects of possible single fault conditions in the unassociated equipment. If the power source is unknown then it should be assumed that the maximum limit of SELV may be applied to the source input under assumed single fault conditions in the source when assessing the charging circuit in the equipment under test.		N/A
4.3.13.5.1	Variation <i>Delete</i> the first paragraph and <i>replace</i> with the following: Except as permitted below, equipment shall be classified and labelled according to IEC 60825-1 or AS/NZS 60825.1, IEC 60825-2 or AS/NZS 60825.2 and IEC 60825-12, as applicable	Deleted.	N/A
	Third paragraph, first sentence, after 'IEC 60825-1', <i>insert</i> the following text: or AS/NZS 60825.1	Inserted.	N/A
	Fourth paragraph, after 'IEC 60825-1', <i>insert</i> the following text: or AS/NZS 60825.1	Inserted.	N/A
4.7	RESISTANCE TO FIRE		N/A
4.7	Addition At the end of Clause 4.7, <i>insert</i> the following text: For alternate tests refer to Clause 4.7.201	Inserted.	N/A
6	CONNECTION TO TELECOMMUNICATIONS NETWORKS		N/A
6.2.2	Variation For Australia only, <i>delete</i> the first paragraph and Note, and <i>replace</i> with the following: In Australia only, compliance with 6.2.2 shall be checked by the tests of both 6.2.2.1 and 6.2.2.2	Deleted.	N/A

IEC60950_1F - ATTACHMENT			
Clause	Requirement + Test	Result - Remark	Verdict
6.2.2.1	Variation For Australia only, <i>delete</i> the first paragraph including the Notes, and <i>replace</i> with the following: In Australia only, the electrical separation is subjected to 10 impulses of alternating polarity, using the impulse test generator Reference 1 of Table N.1. The interval between successive impulses is 60 s and the initial voltage, U_c , is: (i) for 6.2.1 a): 7.0 kV for hand-held telephones and for headsets and 2.5 kV for other equipment; and (ii) for 6.2.1 b) and 6.2.1 c): 1.5kV	Deleted.	N/A
	NOTE 201 The 7 kV impulse simulates lightning surges on typical rural and semi-rural network lines		N/A
	NOTE 202 The value of 2.5 kV for 6.2.1 a) was chosen to ensure the adequacy of the insulation concerned and does not necessarily simulate likely overvoltages		N/A
6.2.2.2	Variation For Australia only, delete the second paragraph including the Note, and replace with the following: In Australia only, the a.c. test voltage is (i) for 6.2.1 a): 3kV; and (ii) for 6.2.1b) and 6.2.1c): 1.5kV		N/A
	NOTE 201 Where there are capacitors across the insulation under test, it is recommended that d.c. test voltages are used.		N/A
	NOTE 202 The 3 kV and 1.5 kV values have been determined considering the low frequency induced voltages from the power supply distribution system.		N/A
7	CONNECTION TO CABLE DISTRIBUTION NETWORK		N/A
7.3	Addition <i>Add</i> the following before the first paragraph: Equipment providing functions that fall only within the scope of AS/NZS 60065 and that incorporate a PSTN interface, are not required to comply with this Clause where the only ports provided on the equipment, in addition to a coaxial cable connection and a PSTN interface, are audio or video ports and analogue or data ports not intended to be used for telecommunications purposes		N/A
Annex P	Addition <i>Add</i> the following Normative References: AS/NZS 3191, Electric flexible cords AS/NZS 3112, Approval and test specification—Plugs and socket-outlets		N/A

IEC60950_1F - ATTACHMENT			
Clause	Requirement + Test	Result - Remark	Verdict
	Special national conditions (if any)		
1.2.12	FLAMMABILITY		P
1.2.12.15	Addition After Clause 1.2.12.15, <i>insert</i> the following new clause:	Inserted.	P
1.2.12.201	POTENTIAL IGNITION SOURCE Possible fault which can start a fire if the open-circuit voltage measured across an interruption or faulty contact exceeds a value of 50 V (peak) a.c. or d.c. and the product of the peak value of this voltage and the measured r.m.s. current under normal operating conditions exceeds 15 VA	Considered.	P
	Such a faulty contact or interruption in an electrical connection includes those which may occur in CONDUCTIVE PATTERNS on PRINTED BOARDS		N/A
	NOTE 1 An electronic protection circuit may be used to prevent such a fault from becoming a POTENTIAL IGNITION SOURCE		N/A
	NOTE 2 This definition is from AS/NZS 60065:2012, Clause 2.8.11.		N/A
4	PHYSICAL REQUIREMENTS		N/A
4.1	Addition After Clause 4.1, <i>insert</i> new Clause 4.1.201 as follows:		N/A
4.1.201	Display devices used for television purposes Display devices which may be used for television purposes, with a mass of 7 kg or more, shall comply with the requirements for stability and mechanical hazards, including the additional stability requirements for television receivers, specified in AS/NZS 60065	No such components.	N/A
4.3	DESIGN AND CONSTRUCTION		N/A
4.3.8	Addition After Clause 4.3.8, <i>add</i> the following new clause as follows	No such components.	N/A
4.3.8.201	Products containing coin/button cell batteries and batteries designated R1 The requirements of AS/NZS 60065:2012 Amendment 1:2015, Clause 14.10.201 apply for this Clause.		N/A

IEC60950_1F - ATTACHMENT			
Clause	Requirement + Test	Result - Remark	Verdict
4.7	RESISTANCE TO FIRE		N/A
4.7.3.6	Addition After Clause 4.7.3.6, <i>add</i> new clauses as follows:	Added.	N/A
4.7.201	Resistance to fire—Alternative tests	No fire enclosure required.	N/A
4.7.201.1	General Parts of non-metallic material shall be resistant to ignition and spread of fire. This requirement does not apply to decorative trims, knobs and other parts unlikely to be ignited or to propagate flames from inside the apparatus, or the following: a) Components that are contained in an enclosure having a flammability category of V-0 according to AS/NZS 60695.11.10 and having openings only for the connecting wires filling the openings completely, and for ventilation not exceeding 1 mm in width regardless of length.		N/A
	b) The following parts which would contribute negligible fuel to a fire: – small mechanical parts, the mass of which does not exceed 4 g, such as mounting parts, gears, cams, belts and bearings; – small electrical components, such as capacitors with a volume not exceeding 1,750 mm ³ , integrated circuits, transistors and optocoupler packages, if these components are mounted on material of flammability category V-1, or better, according to AS/NZS 60695.11.10		N/A
	NOTE In considering how to minimize propagation of fire and what 'small parts' are, account should be taken of the cumulative effect of small parts adjacent to each other for the possible effect of propagating the fire from one part to another		N/A
	<i>Compliance shall be checked by the tests of 4.7.201.2, 4.7.201.3, 4.7.201.4 and 4.7.201.5</i>		N/A
	<i>For the base material of printed boards, compliance shall be checked by the test of 4.7.201.5</i>		N/A
	The tests shall be carried out on parts of non-metallic material which have been removed from the apparatus. When the glow-wire test is carried out, the parts shall be placed in the same orientation as they would be in normal use. These tests are not carried out on internal wiring		N/A

IEC60950_1F - ATTACHMENT			
Clause	Requirement + Test	Result - Remark	Verdict
4.7.201.2	<p>Testing of non-metallic materials</p> <p>Parts of non-metallic material shall be subject to the glow-wire test of AS/NZS 60695.2.11 which shall be carried out at 550°C</p> <p>Parts for which the glow-wire test cannot be carried out, such as those made of soft or foamy material, shall meet the requirements specified in ISO 9772 for category FH-3 material. The glow-wire test shall be not carried out on parts of material classified at least FH-3 according to ISO 9772 provided that the sample tested was not thicker than the relevant part.</p>		N/A
4.7.201.3	<p>Testing of insulating materials</p> <p>Parts of insulating material supporting POTENTIAL IGNITION SOURCES shall be subject to the glow-wire test of AS/NZS 60695.2.11 which shall be carried out at 750°C.</p> <p>The test shall be also carried out on other parts of insulating material which are within a distance of 3 mm of the connection.</p> <p>NOTE Contacts in components such as switch contacts are considered to be connections.</p> <p>For parts which withstand the glow-wire test but produce a flame, other parts above the connection within the envelope of a vertical cylinder having a diameter of 20 mm and a height of 50 mm shall be subjected to the needle-flame test. However, parts shielded by a barrier which meets the needle-flame test shall not be tested.</p> <p>The needle-flame test shall be made in accordance with AS/NZS 60695.11.5 with the following modifications:</p>		N/A

IEC60950_1F - ATTACHMENT													
Clause	Requirement + Test	Result - Remark	Verdict										
	<table border="1"> <thead> <tr> <th>Clause of AS/NZS 60695.11.5</th> <th>Change</th> </tr> </thead> <tbody> <tr> <td colspan="2">9 Test procedure</td> </tr> <tr> <td>9.2 Application of Needle-flame</td> <td><i>Delete</i> the first and second paragraphs and <i>replace</i> with the following: The specimen shall be arranged so that the flame can be applied to a vertical or horizontal edge as shown in the examples of Figure 1. If possible the flame shall be applied at least 10 mm from a corner. The duration of application of the test flame shall be 30 s ± 1 s</td> </tr> <tr> <td>9.3 Number of test specimens</td> <td><i>Delete</i> existing text and <i>replace</i> with the following: The test shall be made on one specimen. If the specimen does not withstand the test, the test may be repeated on two further specimens, both of which shall withstand the test.</td> </tr> <tr> <td>11 Evaluation of test results</td> <td><i>Delete</i> existing text and <i>replace</i> with the following: The duration of burning (tb) shall not exceed 30 s. However, for printed circuit boards, it shall not exceed 15s</td> </tr> </tbody> </table>	Clause of AS/NZS 60695.11.5	Change	9 Test procedure		9.2 Application of Needle-flame	<i>Delete</i> the first and second paragraphs and <i>replace</i> with the following: The specimen shall be arranged so that the flame can be applied to a vertical or horizontal edge as shown in the examples of Figure 1. If possible the flame shall be applied at least 10 mm from a corner. The duration of application of the test flame shall be 30 s ± 1 s	9.3 Number of test specimens	<i>Delete</i> existing text and <i>replace</i> with the following: The test shall be made on one specimen. If the specimen does not withstand the test, the test may be repeated on two further specimens, both of which shall withstand the test.	11 Evaluation of test results	<i>Delete</i> existing text and <i>replace</i> with the following: The duration of burning (tb) shall not exceed 30 s. However, for printed circuit boards, it shall not exceed 15s		
Clause of AS/NZS 60695.11.5	Change												
9 Test procedure													
9.2 Application of Needle-flame	<i>Delete</i> the first and second paragraphs and <i>replace</i> with the following: The specimen shall be arranged so that the flame can be applied to a vertical or horizontal edge as shown in the examples of Figure 1. If possible the flame shall be applied at least 10 mm from a corner. The duration of application of the test flame shall be 30 s ± 1 s												
9.3 Number of test specimens	<i>Delete</i> existing text and <i>replace</i> with the following: The test shall be made on one specimen. If the specimen does not withstand the test, the test may be repeated on two further specimens, both of which shall withstand the test.												
11 Evaluation of test results	<i>Delete</i> existing text and <i>replace</i> with the following: The duration of burning (tb) shall not exceed 30 s. However, for printed circuit boards, it shall not exceed 15s												
	The needle-flame test shall not be carried out on parts of material classified as V-0 or V-1 according to AS/NZS 60695.11.10, provided that the sample tested was not thicker than the relevant part		N/A										

IEC60950_1F - ATTACHMENT			
Clause	Requirement + Test	Result - Remark	Verdict
4.7.201.4	<p>Testing in the event of non-extinguishing material</p> <p>If parts, other than enclosures, do not withstand the glow wire tests of 4.7.201.3 by failure to extinguish within 30 s after the removal of the glow-wire tip, the needle-flame test detailed in 4.7.201.3 shall be made on all parts of non-metallic material which are within a distance of 50 mm or which are likely to be impinged upon by flame during the tests of 4.7.201.3. Parts shielded by a separate barrier which meets the needle-flame test need not be tested.</p>		N/A
	NOTE 1 If the enclosure does not withstand the glow-wire test the equipment is considered to have failed to meet the requirements of Clause 4.7.201 without the need for consequential testing.		N/A
	NOTE 2 If other parts do not withstand the glow-wire test due to ignition of the tissue paper and if this indicates that burning or glowing particles can fall onto an external surface underneath the equipment, the equipment is considered to have failed to meet the requirements of Clause 4.7.201 without the need for consequential testing		N/A
	NOTE 3 Parts likely to be impinged upon by the flame are considered to be those within the envelope of a vertical cylinder having a radius of 10 mm and a height equal to the height of the flame, positioned above the point of the material supporting, in contact with, or in close proximity to, connections.		N/A
4.7.201.5	<p>Testing of printed boards</p> <p>The base material of printed boards shall be subjected to the needle-flame test of Clause 4.7.201.3. The flame shall be applied to the edge of the board where the heat sink effect is lowest when the board is positioned as in normal use. The flame shall not be applied to an edge, consisting of broken perforations, unless the edge is less than 3 mm from a POTENTIAL IGNITION SOURCE.</p>		N/A

IEC60950_1F - ATTACHMENT			
Clause	Requirement + Test	Result - Remark	Verdict
	<p>The test is not carried out if the</p> <ul style="list-style-type: none"> – Printed board does not carry any POTENTIAL IGNITION SOURCE; – Base material of printed boards, on which the available apparent power at a connection exceeds 15 VA operating at a voltage exceeding 50 V and equal or less than 400 V (peak) a.c. or d.c. under normal operating conditions, is of flammability category V-1 or better according to AS/NZS 60695.11.10, or the printed boards are protected by an enclosure meeting the flammability category V-0 according to AS/NZS 60695.11.10, or made of metal, having openings only for connecting wires which fill the openings completely; or – Base material of printed boards, on which the available apparatus power at a connection exceeds 15 VA operating at a voltage exceeding 400 V (peak) a.c. or d.c. under normal operating conditions, and base material of printed boards supporting spark gaps which provides protection against overvoltages, is of flammability category V-0 according to AS/NZS 60695.11.10 or the printed boards are contained in a metal enclosure, having openings only for connecting wires which fill the openings completely <p><i>Compliance shall be determined using the smallest thickness of the material.</i></p>		
	<p>NOTE Available apparent power is the maximum apparent power which can be drawn from the supplying circuit through a resistive load whose value is chosen to maximise the apparent power for more than 2 m when the circuit supplied is disconnected.</p>		N/A

IEC60950_1F - ATTACHMENT			
Clause	Requirement + Test	Result - Remark	Verdict

ATTACHMENT TO TEST REPORT IEC 60950-1 with A1:2009 and A2:2013 CANADA NATIONAL DIFFERENCES Information technology equipment – Safety – Part 1: General requirements	
Differences according to:	CAN/CSA C22.2 No. 60950-1-07, Amd 1:2011, Amd 2:2014
Attachment Form No. :	CA_ND_IEC60950_1F
Attachment Originator :	CSA
Master Attachment :	Date (2015-05)
Copyright © 2015 IEC System for Conformity Testing and Certification of Electrical Equipment (IECEE), Geneva, Switzerland. All rights reserved.	

1.1.1	All equipment is to be designed to allow installation in accordance with the National Electrical Code (NEC), ANSI/NFPA 70, the Canadian Electrical Code (CEC), Part I, CAN/CSA C22.1, and when applicable, the National Electrical Safety Code, IEEE C2. Also, unless marked or otherwise identified, installation is allowed per the Standard for the Protection of Electronic Computer/Data-Processing Equipment, ANSI/NFPA 75.	In accordance with the National Electrical Code (NEC), ANSI/NFPA 70, and unless marked or otherwise identified, the Standard for Electronic Computer / Data-Processing Equipment, ANSI/NFPA 75.	P
1.1.2	Baby monitors are required to additionally comply with ASTM F2951, Consumer Safety Specification for Baby Monitors.		N/A
1.4.14	For Pluggable Equipment Type A, the protection in the installation is assumed to be 20A.		N/A
1.5.5	For lengths exceeding 3.05 m, external interconnecting flexible cord and cable assemblies are required to be a suitable cable type (e.g., DP, CL2) specified in the CEC/NEC.		N/A
	For lengths 3.05 m or less, external interconnecting flexible cord and cable assemblies that are not types specified in the CEC are required to have special construction features and identification markings.		N/A

IEC60950_1F - ATTACHMENT			
Clause	Requirement + Test	Result - Remark	Verdict
1.7.1	Equipment for use on a.c. mains supply systems with a neutral and more than one phase conductor (e.g. 120/240 V, 3-wire) require a special marking format for electrical ratings. A voltage rating that exceeds an attachment plug cap rating is only permitted if it does not exceed the extreme operating conditions in Table 2 of CAN/CSA C22.2 No. 235, and if it is part of a range that extends into the Table 2 "Normal Operating Conditions." Likewise, a voltage rating shall not be lower than the specified "Normal Operating Conditions," unless it is part of a range that extends into the "Normal Operating Conditions."		N/A
1.7.7	Wiring terminals intended to supply Class 2 outputs in accordance with CEC Part 1 or NEC shall be marked with the voltage rating and "Class 2" or equivalent. Marking shall be located adjacent to the terminals and shall be visible during wiring.		N/A
2.5	Where a fuse is used to provide Class 2, Limited Power Source, or TNV current limiting, it shall not be operator-accessible unless it is not interchangeable.		N/A
2.6	Equipment with isolated ground (earthing) receptacles are required to comply with NEC 250.146(D) and CEC 10-112 and 10-906(8).		N/A
2.7.1	Suitable NEC/CEC branch circuit protection rated at the maximum circuit rating is required for all standard supply outlets and receptacles (such as supplied in power distribution units) if the supply branch circuit protection is not suitable. Power distribution transformers distributing power at 100 volts or more, and rated 10 kVA or more, require special transformer overcurrent protection.		N/A
3.2	Wiring methods (terminals, leads, etc.) used for the connection of the equipment to the mains shall be in accordance with the NEC/CEC.		N/A
3.2.1	Power supply cords are required to have attachment plugs rated not less than 125 percent of the rated current of the equipment.		N/A

IEC60950_1F - ATTACHMENT			
Clause	Requirement + Test	Result - Remark	Verdict
3.2.1.2	Equipment connected to a centralized d.c. power system, and having one pole of the DC mains input terminal connected to the main protective earthing terminal in the equipment, is required to comply with special earthing, wiring, marking and installation instruction requirements.		N/A
3.2.3	Permanent connection of equipment to the mains supply by a power supply cord is not permitted, except for certain equipment, such as ATMs.		N/A
3.2.5	Power supply cords are required to be no longer than 4.5 m in length. Flexible power supply cords are required to be compatible with Tables 11 and 12 of the CEC and Article 400 of the NEC.		N/A
3.2.9	Permanently connected equipment is required to have a suitable wiring compartment and wire bending space.		N/A
3.3	Wiring terminals and associated spacings for field wiring connections shall comply with CSA C22.2 No. 0.		N/A
3.3.3	Wire binding screws are not permitted to attach conductors larger than 10 AWG (5.3 mm ²).		N/A
3.3.4	Terminals for permanent wiring, including protective earthing terminals, are required to be suitable for Canadian/US wire gauge sizes, rated 125 percent of the equipment rating, and be specially marked when specified (1.7.7).		N/A
3.4.2	Motor control devices are required for cord-connected equipment with a motor if the equipment is rated more than 12 A, or if the motor has a nominal voltage rating greater than 120 V, or is rated more than 1/3 hp (locked rotor current over 43 A).		N/A
3.4.8	Vertically-mounted disconnect switches and circuit breakers are required to have the "on" position indicated by the handle in the up position.		N/A
3.4.11	For computer room applications, equipment with battery systems capable of supplying 750 VA for five minutes are required to have a battery disconnect means that may be connected to the computer room remote power-off circuit.		N/A
4.3.12	The maximum quantity of flammable liquid stored in equipment is required to comply with NFPA 30.		N/A

IEC60950_1F - ATTACHMENT			
Clause	Requirement + Test	Result - Remark	Verdict
4.3.13.5	Equipment with lasers is required to meet the Canadian Radiation Emitting Devices Act, REDR C1370 and/or Code of Federal Regulations 21 CFR 1040, as applicable.		N/A
4.7	For computer room applications, automated information storage systems with combustible media greater than 0.76 m ³ (27 cu ft) are required to have a provision for connection of either automatic sprinklers or a gaseous agent extinguishing system with an extended discharge.		N/A
4.7.3.1	For computer room applications, enclosures with combustible material measuring greater than 0.9 m ² (10 sq ft) or a single dimension greater than 1.8 m (6 ft) are required to have a flame spread rating of 50 or less. For other applications, enclosures with the same dimensions require a flame spread rating of 200 or less.		N/A
	Non-metallic enclosures of equipment for use in spaces used for environmental air (plenums) are required to comply with UL 2043.		N/A
Annex H	Equipment that produces ionizing radiation is required to comply with the Canadian Radiation Emitting Devices Act, REDR C1370 and/or Code of Federal Regulations, 21 CFR 1020, as applicable.		N/A
<p>OTHER DIFFERENCES</p> <p>The following key national differences are based on requirements other than national regulatory requirements.</p>			

IEC60950_1F - ATTACHMENT			
Clause	Requirement + Test	Result - Remark	Verdict
1.5.1	<p>Some components and materials associated with the risk of fire, electric shock, or personal injury are required to have component or material ratings in accordance with the applicable national (Canadian and/or U.S.) component or material standard requirements. These components include:</p> <p>attachment plugs, battery packs (rechargeable type, used with transportable equipment), cathode ray tubes, circuit breakers, communication circuit accessories, connectors (used for current interruption of non-LPS circuits), cord sets and power supply cords, direct plug-in equipment, enclosures (outdoor), flexible cords and cables, fuses (branch circuit), fuseholders, ground-fault current interrupters, industrial control equipment, insulating tape, interconnecting cables, lampholders, limit controls, printed wiring, protectors for communications circuits, receptacles, solid state controls, supplementary protectors, switches (including interlock switches), thermal cutoffs, thermostats, (multi-layer) transformer winding wire, transient voltage surge suppressors, tubing, wire connectors, and wire and cables.</p>	<p>All components identified are either complied with IEC standards or relevant requirements of CSA and UL component standards. (See appended Table 1.5.1).</p>	P
1.6.1.2	<p>A circuit for connection to the DC Mains Supply is classified as either a SELV Circuit, TNV-2 Circuit or Hazardous Voltage Circuit depending on the maximum operating voltage of the supply. This maximum operating voltage shall include consideration of the battery charging "float voltage" associated with the intended supply system, regardless of the marked power rating of the equipment.</p>		N/A
2.3.1	<p>For TNV-2 and TNV-3 circuits with other than ringing signals and with voltages exceeding 42.4 V_{peak} or 60 V_{d.c.}, the maximum acceptable current through a 2000 ohm resistor (or greater) connected across the voltage source with other loads disconnected is 7.1 mA peak or 30 mA d.c. under normal operating conditions.</p>		N/A
2.3.2.1	<p>In the event of a single fault between TNV and SELV circuits, the limits of 2.2.3 apply to SELV circuits and accessible conductive parts.</p>		N/A
2.6.2	<p>Equipment with functional earthing is required to be marked with the functional earthing symbol (IEC 60417-6092).</p>		N/A



IEC60950_1F - ATTACHMENT			
Clause	Requirement + Test	Result - Remark	Verdict
2.6.3.4	Protective bonding conductors of non-standard protective bonding constructions (e.g., printed circuit traces) may be subjected to the additional limited short circuit test conditions specified.		N/A
4.2.8.1	Enclosures around CRTs with a face diameter of 160 mm or more are required to reduce the risk of injury due to the implosion of the CRT.		N/A
4.3.2	Equipment with handles is required to comply with special loading tests.		N/A
5.1.8.3	Equipment intended to receive telecommunication ringing signals is required to comply with a special touch current measurement tests.		N/A
5.3.7	Internal (e.g., card cage) SELV circuit connectors and printed wiring board connectors that are accessible to the operator and that deliver power are to be overloaded. During abnormal operating testing, if a circuit is interrupted by the opening of a component, the test shall be repeated twice (three tests total) using new components as necessary.	See appended table 5.3.	P
6.4	Equipment intended for connection to telecommunication network outside plant cable is required to be protected against overvoltage from power line crosses in accordance with 6.4 and Annex NAC.		N/A
Annex EE	UL articulated accessibility probe (Fig EE.3) required for assessing accessibility to document/media shredders instead of the Figure 2A test finger.		N/A
M.2	Continuous ringing signals up to 16 mA only are permitted if the equipment is subjected to special installation and performance restrictions.		N/A
Annex NAD	Equipment connected to a telecommunication and cable distribution networks and supplied with an earphone intended to be held against, or in the ear is required to comply with special acoustic pressure requirements.		N/A

IEC60950_1F - ATTACHMENT			
Clause	Requirement + Test	Result - Remark	Verdict

<p>ATTACHMENT TO TEST REPORT IEC 60950-1 CHINESE NATIONAL DIFFERENCES Information technology equipment – Safety - Part 1: General requirements</p>
<p>Differences according to.....: CQC GB4943.1-2011</p>



1.1.2	<p>GB 4943.1-2011 applies to equipment for use at altitudes not exceeding 5000m above sea level, primarily in regions with moderate or tropical climates.</p> <p>Amend the third dashed paragraph of 1.1.2 as: ——equipment intended to be used in vehicles, on board ships or aircraft, at altitudes greater than 5000m;</p>		N/A
1.4.5	<p>After the third paragraph, add a paragraph: If the equipment is intended for direct connection to an AC mains supply, the tolerances on RATED VOLTAGE shall be taken as +10%,-10% unless a wider tolerance is declared by the manufacturer. The first dash paragraph "-the RATED VOLTAGE is 230V single -phase or 400V three-phase, in which case the tolerance shall be taken as +10% and -10%" of IEC 60950-1:2005 is deleted in GB 4943.1-2011.</p>		N/A
1.4.12.1	<p>T_{ma} in clause 1.4.12.1 amended as: T_{ma}: is the maximum ambient temperature permitted by the manufacturer's specification, or 35°C, whichever is greater.</p> <p>Add note 1: For equipment not to be operated at tropical climatic conditions, T_{ma}: is the maximum ambient temperature permitted by the manufacturer's specification, or 25°C, whichever is greater.</p> <p>Add note 2: For equipment is to be operated at 2000m-5000m above sea leave, its temperature test conditions and temperature limits are under consideration.</p>	See General product information.	P
1.5.2	<p>Add a note behind the first break off section in Clause 1.5.2: A component used shall comply with related requirements corresponding altitude of 5000m.</p>		N/A

IEC60950_1F - ATTACHMENT			
Clause	Requirement + Test	Result - Remark	Verdict
1.7	Add one paragraph before the last paragraph: The required marking and instruction should be given in normative Chinese unless otherwise specified.		N/A
1.7.1	Based on the AC mains supply of China, the RATED VOLTAGE should be 220V (single phase) or 380V (three-phases) for single rated voltage, for RATED VOLTAGE RANGE, it should cover 220V or 380V (three-phases), for multiple RATED VOLTAGES, one of them should be 220V or 380V (three-phases) and set on 220V or 380V (three-phases) when manufactured. And the RATED FREQUENCY or RATED FREQUENCY RANGE should be 50Hz or include 50Hz.		N/A

IEC60950_1F - ATTACHMENT			
Clause	Requirement + Test	Result - Remark	Verdict
1.7.2.1	<p>Add requirements of warning for equipment intended to be used at altitudes not exceeding 2000m or at non-tropical climate regions:</p> <p>For equipment intended to be used at altitude not exceeding 2000m, a warning label containing the following or a similar appropriate wording, or a symbol as in annex DD shall fixed to the equipment at readily visible place.</p> <p>"Only used at altitude not exceeding 2000m."</p>  <p>For equipment intended to be used in not-tropical climate regions, a warning label containing the following or a similar appropriate wording, or a symbol as in annex DD shall fixed to the equipment at readily visible place.</p> <p>"Only used in not-tropical climate regions."</p>  <p>If only the symbol used, the explanation of the symbol shall be contained in the instruction manual.</p> <p>The above statements shall be given in a language acceptable to the regions where the apparatus is intended to be used.</p>	<p>When the equipment marketed to China, the warning label will be marked on marking plate in Chinese, the meaning of the label and instructions will be described in manual in Chinese.</p>	N/A
2.7.1	<p>Amended the first paragraph as:</p> <p>Protection in PRIMARY CIRCUITS against overcurrent short-circuits and earth faults shall be provided as an integral part of the equipment except special provisions. And the protective device shall meet the requirement of Clause 5.3.</p> <p>Delete note of Clause 2.7.1.</p>		N/A

IEC60950_1F - ATTACHMENT			
Clause	Requirement + Test	Result - Remark	Verdict
2.9.2	<p>First section of Clause 2.9.2 amended as two sections:</p> <p>Where required by 2.9.1, 2.10.8.3, 2.10.10 or 2.10.11, humidity conditioning is conducted for 120 h in a cabinet or room containing air with ambient temperature $40\pm 2^{\circ}\text{C}$ and a relative humidity of $(93\pm 3)\%$. During this conditioning the component or subassembly is not energized.</p> <p>For equipment not to be operated at tropical climatic conditions, Where required by 2.9.1, 2.10.8.3, 2.10.10 or 2.10.11, humidity conditioning is conducted for 48 h in a cabinet or room containing air with a relative humidity of $(93\pm 3)\%$. The temperature of the air, at all places where samples can be located, is maintained within 2°C of any convenient value between 20°C and 30°C such that condensation does not occur.</p> <p>Due to pretreatment of equipment operated at high altitude area is humidity conditioning withstand hot shock, specific requirements are to be considered.</p> <p>Add note: For equipment to be operated at 2000 m - 5000m above sea level, assessment and requirement of humidity conditioning for Insulation material properties are considered.</p>		N/A
2.10.3.1	<p>Amend the third paragraph of Clause 2.10.3.1 to be:</p> <p>These requirements apply for equipment to be operated up to 2000 m above sea level. For equipment to be operated at more than 2000 m above sea level and up to 5000m above sea level, the minimum CLEARANCE shall be multiplied by the factor 1.48 corresponding altitude of 5000m given in Table A.2 of IEC 60664-1. For equipment to be operated at more than 5000 m above sea level, the minimum CLEARANCE shall be multiplied by the factor given in Table A.2 of IEC 60664-1. Linear interpolation is permitted between the nearest two points in Table A.2. The calculated minimum CLEARANCE using this multiplication factor shall be rounded up to the next higher 0,1 mm increment.</p>		N/A
2.10.3.3 & 2.10.3.4	Add "(applicable for altitude up to 2000m)" in header of Table 2K , 2L and 2M.	Added.	N/A

IEC60950_1F - ATTACHMENT			
Clause	Requirement + Test	Result - Remark	Verdict
2.10.3.4	Add a new section above Table 2K and in Clause 2.10.3.4: Minimum CLEARANCES determined by above rules apply for equipment to be operated up to 2000m above sea level. For equipment to be operated at 2000 m - 5000m above sea level, the minimum CLEARANCE shall be multiplied by the factor 1.48 corresponding altitude of 5000m given in Table A.2 of GB/T16935.1 (IEC 60664-1). For equipment to be operated at more than 5000 m above sea level, the minimum CLEARANCE shall be multiplied by the factor given in Table A.2 of GB/T16935.1.		N/A
3.2.1.1	Add a paragraph before the last paragraph: Plugs connected to AC mains supply shall comply with GB 1002 or GB 1003 or GB/T 11918 as applicable.		N/A
4.2.8	Clause 4.2.8 cathode ray tubes quoted Clause 18 of GB8898-2011. Delete note of Clause 4.2.8.		N/A
Annex E	Last section of Annex E amended as: For comparison of winding temperatures determined by the resistance method of this annex with the temperature limits of Table 4B, 35°C shall be added to the calculated temperature rise. And add note: for equipment not to be operated at tropical climatic conditions, 25°C shall be added to the calculated temperature rise to compare with the temperature of Table 4B.		N/A
Annex G.6	Change the second section of Clause G.6 to be: For equipment to be operated at 2000 – 5000 m above sea level, the minimum CLEARANCE shall be multiplied by the factor 1.48 corresponding altitude of 5000m given in Table A.2 of GB/T16935.1. For equipment to be operated at more than 5000 m above sea level, the minimum CLEARANCE shall be multiplied by the factor given in Table A.2 of IEC 60664-1. Linear interpolation is permitted between the nearest two points in Table A.2. The calculated minimum CLEARANCE using this multiplication factor shall be rounded up to the next higher 0,1 mm increment.		N/A

IEC60950_1F - ATTACHMENT			
Clause	Requirement + Test	Result - Remark	Verdict
Annex BB (informative)	Amended as : The differences between Chinese national standards GB 4943.1-2011 and GB 4943-2001.		P
Annex DD (normative)	<p>Added annex DD: Instructions for the new safety warning labels.</p> <p>DD.1 Altitude warning label</p>  <p>Meaning of the label: Evaluation for apparatus only based on altitude not exceeding 2000m, therefor it's the only operating condition applied for the equipment .There may be some potential safety hazard if the equipment is used at altitude above 2000m.</p> <p>DD.2 Climate warning label</p>  <p>Meaning of the label: Evaluation for apparatus only based on temperate climate condition, therefor it's the only operating condition applied for the equipment .There may be some potential safety hazard if the equipment is used in tropical climate region.</p>	When the equipment marketed to China, the warning label will be marked on marking plate in Chinese, the meaning of the label and instructions will be described in manual in Chinese.	N/A
Annex EE (informative)	Added annex EE: Illustration relative to safety explanation in normative Chinese · Tibetan · Mongolian · Zhuang Language and Uighu.	Review it when the equipment marketed to China.	N/A
Other amendments	In accordance with the relevant CTL decisions and the amendments of IEC 60950-1, the specific requirements or mistakes in IEC standard are corrected or editorially modified in this part, Including clause 1.7, 2.1.1.7, 2.9.2, Table 2H, Figure 2H, F.8, F.9, M.3 and Annex U.		N/A

IEC60950_1F - ATTACHMENT			
Clause	Requirement + Test	Result - Remark	Verdict
Quoting standards and reference documents	<p>The principles of quoting and referring to other standards in Annex P and reference documents of IEC 60950-1 are as follows:</p> <p>If the date of the reference document is given, only that edition applies, excluding any subsequent corrigenda and amendments. However, parties to agreements based on this part are encouraged to investigate the possibility of applying the most recent editions of the reference documents. For undated references, the latest edition of the referenced document applies, including any corrigenda and amendments.</p> <p>For the usage of international standards in Chinese national standards and industry standards is various, in the aim of achieving easy operation and based on the requirements of GB/T 1.1 and GB/T 20000.2, when quoting an entire international standard in the normative quoting files and reference documents of Annex P of this part, the principles of quotation are as follows:</p> <ul style="list-style-type: none"> - If there is no national standard or industry standard corresponding to the international standard, then the international standard is quoted; - If there is national standard or industry standard corresponding to the international standard, then either the national or industry standard is quoted; - If the date of the national standard or industry standard is not given, the latest edition of the standard applies; - The national standard or industry standard number, corresponding international standard number and the consistency level code should be identified in parentheses behind the listed national standard or industry standard. 		N/A

IEC60950_1F - ATTACHMENT			
Clause	Requirement + Test	Result - Remark	Verdict
	<p>When quoting several chapters or clauses of the international standard, the principles of quotation are as follows:</p> <ul style="list-style-type: none"> - If there is no national standard or industry standard corresponding to the international standard, then the international standard is quoted; - If there is national standard or industry standard corresponding to the international standard, then either the national or industry standard is quoted. <p>Meanwhile, in order to retain the relevant information on international standards, informative annex CC is increased, which gives the table about the comparison of the normative quoting files and reference documents in IEC 60950-1:2005 and GB 4943.1-2011.</p>		



IEC60950_1F - ATTACHMENT			
Clause	Requirement + Test	Result - Remark	Verdict

<p>ATTACHMENT TO TEST REPORT IEC 60950-1 GERMANY NATIONAL DIFFERENCES</p> <p>Information technology equipment – Safety – Part 1: General requirements</p> <p>Differences according to.....: VDE 0805-1:2011-01</p>

Annex ZC, 1.7.2.1	According to GPSG, section 2, clause 4: If certain rules on the use, supplementation or maintenance of an item of technical work equipment or ready-to-use commodity must be observed in order to guarantee safety and health, instructions for use in German must be supplied when it is brought into circulation.		N/A
----------------------	--	--	-----

IEC60950_1F - ATTACHMENT			
Clause	Requirement + Test	Result - Remark	Verdict

ATTACHMENT TO TEST REPORT IEC 60950 - 1, ed2, amd1 ISRAEL NATIONAL DIFFERENCES (INFORMATION TECHNOLOGY EQUIPMENT – SAFETY: GENERAL REQUIREMENTS)			
Differences according to : National standard SI 60950 - 1, ed2, amd1.			
Attachment Form No. : IL_ND_IEC60950_1C			
Attachment Originator : Standards Institution of Israel			
Master Attachment : Date 2015-12			
Copyright © 2015 IEC System of Conformity Assessment Schemes for Electrotechnical Equipment and Components (IECEE System). All rights reserved.			

	National Differences		N/A
1.6	Power interface The clause is applicable with the following addition:		N/A
1.6.1	AC Power distribution systems		N/A
	At the end of the clause, the following note shall be added: Note: In Israel, the clause is subject to the Electricity Law, 1954, its Regulations and updates.		N/A
1.7	Marking and instructions The clause is applicable with the following additions:	When the equipment marketed to Israel, the marking and instructions will be described in Hebrew language.	N/A
1.7.1	Power rating		N/A
	Subclause 1.7.201 shall be added after the clause, as follows:		N/A

IEC60950_1F - ATTACHMENT			
Clause	Requirement + Test	Result - Remark	Verdict
1.7.201	<p>Marking in the Hebrew language</p> <p>The marking in the Hebrew language shall be in accordance with the Consumer Protection Order (Marking of goods), 1983.</p> <p>In addition to the marking required by clause 1.7.1, the following details shall be marked in the Hebrew language.</p> <p>The details shall be marked on the apparatus or on its package, or on a label properly attached to the apparatus or on the package, by bonding or sewing, in a manner that the label cannot be easily removed.</p> <ol style="list-style-type: none"> 1. Name of the apparatus and its commercial designation; 2. Manufacturer's name and address. If the apparatus is imported, the importer's name and address; 3. Manufacturer's registered trademark, if any; 4. Name of the model and serial number, if any; 5. Country of manufacture. <p>The items shall be marked on the apparatus or on its packaging, or on a label well attached to the apparatus or its packaging, by bonding or sewing, such that the label cannot be easily removed.</p>		N/A
1.7.2	Safety instructions and marking		N/A
1.7.2.1	<p>General</p> <p>- The following shall be added at the end of the clause:</p> <p>All the instruction and all the warnings related to safety shall also be written in the Hebrew language.</p>		N/A
At the end of clause 1, clause 1.201 shall be added as follows:			
1.201	<p>Power consumption in standby mode</p> <p>The equipment shall comply with the requirements of the Energy Sources Regulations (Maximum electrical power in standby mode for domestic and office electrical appliances), 2011, with a permitted deviation of up to 10 %.</p>		N/A
2	<p>Protection from hazards</p> <p>The clause is applicable with the following additions:</p>		N/A

IEC60950_1F - ATTACHMENT			
Clause	Requirement + Test	Result - Remark	Verdict
2.9.4	<p>Separation from hazardous voltages</p> <p>The following shall be added at the beginning of the clause:</p> <p>According to the Electricity Law, 1954, and the Electricity Regulations (Earthing and protection means from electricity at voltages up to 1,000 V), 1991, in Israel, seven means of protection from electricity are permitted, as follows:</p> <ol style="list-style-type: none"> 1) Network system earthing - (TN-C-S, TN-S); 2) Network system earthing - (TT); 3) Network Insulation Terre - (IT); 4) Isolated transformer; 5) Safety extra low voltage; 6) Residual current circuit breaker; 7) Reinforced insulation; Double insulation 		N/A
Clause 2.201 shall be added at the end of clause 2, as follows:			
2.201	<p>Prevention of electromagnetic interference</p> <p>The device shall meet the requirements of the relevant part of the Israeli Standard series, SI 961.</p> <p>If the device contains components for prevention of electromagnetic interference, the devices shall not lower the safety level of the device, as required by this Standard.</p>		N/A
3	<p>Wiring, connections and supply</p> <p>The clause is applicable with the following additions:</p>		N/A
3.2	Connection to a mains supply		N/A
3.2.1	Means of connection		N/A
3.2.1.1	<p>Connection to an a.c. mains supply</p> <p>After the Note, the following note shall be added:</p> <p>Note: In Israel, the supply plug shall comply with the requirements in Israeli Standard, SI 32 Part 1.1.</p>		N/A
3.2.1.2	<p>Connection to a d.c. mains supply</p> <p>After the first paragraph, the following note shall be added:</p> <p>Note: As of the date of publication of this Standard, there is no Israeli Standard for connection accessories to d.c.</p>		N/A

IEC60950_1F - ATTACHMENT			
Clause	Requirement + Test	Result - Remark	Verdict
	Special national conditions (if any)		N/A
	ANNEX P Normative references		N/A
	The annex is applicable with the following modifications and additions: In place of some of the International Standards cited in the Standard and noted in this annex, the following Israeli Standards shall apply:		N/A



IEC60950_1F - ATTACHMENT			
Clause	Requirement + Test	Result - Remark	Verdict

<p>ATTACHMENT TO TEST REPORT IEC 60950-1 KOREA NATIONAL DIFFERENCES Information technology equipment – Safety – Part 1: General requirements</p>
<p>Differences according to.....: K 60950-1</p>

1.5.101	Plugs for the connection of the apparatus to the supply mains shall comply with the Korean requirement (KSC 8305)		N/A
8	EMC The apparatus shall comply with the relevant CISPR standards.		N/A

IEC60950_1F - ATTACHMENT			
Clause	Requirement + Test	Result - Remark	Verdict

ATTACHMENT TO TEST REPORT IEC 60950-1 with A1: 2009 and A2:2013 U.S.A. NATIONAL DIFFERENCES Information technology equipment – Safety – Part 1: General requirements			
Differences according to.....: UL 60950-1-07(Second Edition) + A1: 2011 + A2: 2014			
Attachment Form No.: US_ND_IEC60950_1F			
Attachment Originator: UL			
Master Attachment: Date 2014-07			
Copyright © 2014 IEC System for Conformity Testing and Certification of Electrical Equipment (IECEE), Geneva, Switzerland. All rights reserved.			

SPECIAL NATIONAL CONDITIONS BASED ON REGULATIONS			
1.1.1	All equipment is to be designed to allow installation in accordance with the National Electrical Code (NEC), ANSI/NFPA 70, the Canadian Electrical Code (CEC), Part I, CAN/CSA C22.1, and when applicable, the National Electrical Safety Code, IEEE C2.	All components identified are either complied with IEC standards or relevant requirements of CSA and UL component standards. (See appended Table 1.5.1).	P
	Also, unless marked or otherwise identified, installation is allowed per the Standard for the Protection of Electronic Computer/Data-Processing Equipment, ANSI/NFPA 75.		N/A
1.1.2	Baby monitors are required to additionally comply with ASTM F2951, Consumer Safety Specification for Baby Monitors		N/A
1.4.14	For Pluggable Equipment Type A, the protection in the installation is assumed to be 20A.		N/A
1.5.5	For lengths exceeding 3.05 m, external interconnecting flexible cord and cable assemblies are required to be a suitable cable type (e.g., DP, CL2) specified in the NEC.		N/A
	For lengths 3.05 m or less, external interconnecting flexible cord and cable assemblies that are not types specified in the NEC are required to have special construction features and identification markings.		N/A
1.7.1	Equipment for use on a.c. mains supply systems with a neutral and more than one phase conductor (e.g. 120/240 V, 3-wire) require a special marking format for electrical ratings.		N/A

IEC60950_1F - ATTACHMENT			
Clause	Requirement + Test	Result - Remark	Verdict
	A voltage rating that exceeds an attachment plug cap rating is only permitted if it does not exceed the extreme operating conditions in Table 2 of CAN/CSA C22.2 No. 235, and		N/A
	if it is part of a range that extends into the Table 2 "Normal Operating Conditions." Likewise, a voltage rating shall not be lower than the specified "Normal Operating Conditions," unless it is part of a range that extends into the "Normal Operating Conditions."		N/A
1.7.7	Wiring terminals intended to supply Class 2 outputs in accordance with the NEC or CEC Part 1 shall be marked with the voltage rating and "Class 2" or equivalent.		N/A
	- Marking is located adjacent to the terminals		N/A
	- Marking is visible during wiring		N/A
2.5	Where a fuse is used to provide Class 2, Limited Power Source, or TNV current limiting, it shall not be operator-accessible unless it is not interchangeable.		N/A
2.6	Equipment with isolated ground (earthing) receptacles is in compliance with NEC 250.146(D) and CEC 10-112 and 10-906(8)		N/A
2.7.1	Suitable NEC/CEC branch circuit protection rated at the maximum circuit rating is required for all standard supply outlets and receptacles (such as supplied in power distribution units) if the supply branch circuit protection is not suitable.		N/A
	Power distribution transformers distributing power at 100 volts or more, and rated 10 kVA or more, require special transformer overcurrent protection.		N/A
3.2	Wiring methods (terminals, leads, etc.) used for the connection of the equipment to the mains shall be in accordance with the NEC/CEC.		N/A
3.2.1	Power supply cords are required to have attachment plugs rated not less than 125 percent of the rated current of the equipment.		N/A
3.2.1.2	Equipment connected to a centralized d.c. power system, and having one pole of the DC mains input terminal connected to the main protective earthing terminal in the equipment, is required to comply with special earthing, wiring, marking and installation instruction requirements.		N/A

IEC60950_1F - ATTACHMENT			
Clause	Requirement + Test	Result - Remark	Verdict
3.2.3	Permanent connection of equipment to the mains supply by a power supply cord is not permitted, except for certain equipment, such as ATMs.		N/A
3.2.5	Power supply cords are required to be no longer than 4.5 m in length.		N/A
	Minimum cord length is required to be 1.5 m, with certain constructions such as external power supplies allowed to consider both input and output cord lengths into the requirement.		N/A
	Flexible power supply cords are required to be compatible with Article 400 of the NEC, and Tables 11 and 12 of the CEC.		N/A
3.2.9	Permanently connected equipment is required to have a suitable wiring compartment and wire bending space.		N/A
3.3	Wiring terminals and associated spacings for field wiring connections shall comply with CSA C22.2 No. 0.		N/A
3.3.3	Wire binding screws are not permitted to attach conductors larger than 10 AWG (5.3 mm ²).		N/A
3.3.4	Terminals for permanent wiring, including protective earthing terminals, are suitable for Canadian/US wire gauge sizes, are		N/A
	- rated 125 per cent of the equipment rating, and		N/A
	- are specially marked when specified (1.7.7)		N/A
3.3.5	First column of Table 3E revised to require "Smaller of the RATED CURRENT of the equipment or the PROTECTIVE CURRENT RATING of the circuit under consideration."		N/A
3.4.2	Motor control devices are provided for cord-connected equipment with a motor if the equipment is rated more than 12 A,		N/A
	- or if the motor has a nominal voltage rating greater than 120 V		N/A
	- or is rated more than 1/3 hp (locked rotor current over 43 A)		N/A
3.4.8	Vertically-mounted disconnect switches and circuit breakers are required to have the "on" position indicated by the handle in the up position.		N/A

IEC60950_1F - ATTACHMENT			
Clause	Requirement + Test	Result - Remark	Verdict
3.4.11	For computer room applications, equipment with battery systems capable of supplying 750 VA for five minutes are required to have a battery disconnect means that may be connected to the computer room remote power-off circuit.		N/A
4.3.12	The maximum quantity of flammable liquid stored in equipment is required to comply with NFPA30		N/A
4.3.13.5.1	Equipment with lasers meets the U.S. Code of Federal Regulations 21 CFR 1040 (and the Canadian Radiation Emitting Devices Act, REDR C1370).		N/A
4.7	For computer room applications, automated information storage systems with combustible media greater than 0.76 m ³ (27 cu ft) are required to have a provision for connection of either automatic sprinklers or a gaseous agent extinguishing system with an extended discharge.		N/A
4.7.3.1	For computer room applications, enclosures with combustible material measuring greater than 0.9 m ² (10 sq ft) or a single dimension greater than 1.8 m (6 ft) are required to have a flame spread rating of 50 or less.		N/A
	For other applications, enclosures with the same dimensions require a flame spread rating of 200 or less.		N/A
4.7.3.1	Non-metallic enclosures of equipment for use in spaces used for environmental air (plenums) are required to comply with UL 2043		N/A
Annex H	Equipment that produces ionizing radiation is required to comply with the U.S. Code of Federal Regulations, 21 CFR 1020 (and the Canadian Radiation Emitting Devices Act, REDR C1370).		N/A
OTHER NATIONAL DIFFERENCES			

IEC60950_1F - ATTACHMENT			
Clause	Requirement + Test	Result - Remark	Verdict
1.5.1	Some components and materials associated with the risk of fire, electric shock, or personal injury are required to have component or material ratings in accordance with the applicable national (U.S. and Canadian) component or material requirements. These components include: attachment plugs, battery packs (rechargeable type, used with transportable equipment), cathode ray tubes, circuit breakers, communication circuit accessories, connectors (used for current interruption of non-LPS circuits), cord sets and power supply cords, direct plug-in equipment, electrochemical capacitor modules (energy storage modules with ultracapacitors), enclosures (outdoor), flexible cords and cables, fuses (branch circuit), fuseholders, ground-fault current interrupters, industrial control equipment, insulating tape, interconnecting cables, lampholders, limit controls, printed wiring, protectors for communications circuits, receptacles, solid state controls, supplementary protectors, switches (including interlock switches), thermal cutoffs, thermostats, (multi-layer) transformer winding wire, surge protective devices, tubing, vehicle battery adapters, wire connectors, and wire and cables.	All components identified are either complied with IEC standards or relevant requirements of CSA and UL component standards. (See appended Table 1.5.1).	P
1.6.1.2	A circuit for connection to the DC Mains Supply is classified as a SELV Circuit, a TNV-2 Circuit or a Hazardous Voltage Circuit depending on the maximum operating voltage of the supply.		N/A
	This maximum operating voltage shall include consideration of the battery charging "float voltage" associated with the intended supply system, regardless of the marked power rating of the equipment.		N/A
2.3.1	For TNV-2 and TNV-3 circuits with other than ringing signals and with voltages exceeding 42.4 V _{peak} or 60 V _{d.c.} , the maximum acceptable current through a 2000 ohm resistor (or greater) connected across the voltage source with other loads disconnected is 7.1 mA peak or 30 mA d.c. under normal operating conditions.		N/A
2.3.2.1	In the event of a single fault between TNV and SELV circuits, the limits of 2.2.3 apply to SELV circuits and accessible conductive parts.		N/A
2.6.2	Equipment with functional earthing marked with the functional earthing symbol (IEC 60417-6092)		N/A

IEC60950_1F - ATTACHMENT			
Clause	Requirement + Test	Result - Remark	Verdict
2.6.3.4	Protective bonding conductors of non-standard protective bonding constructions (e.g., printed circuit traces) may be subjected to the additional limited short circuit test conditions specified.		N/A
4.2.8.1	Enclosures around CRTs with a face diameter of 160 mm or more are required to reduce the risk of injury due to the implosion of the CRT.		N/A
4.3.2	Equipment with handles is required to comply with special loading tests.		N/A
4.3.8	Battery packs for both portable and stationary applications comply with special component requirements		N/A
5.1.8.3	Equipment intended to receive telecommunication ringing signals is required to comply with a special touch current measurement tests.		N/A
5.3.7	Internal (e.g., card cage) SELV circuit connectors and printed wiring board connectors that are accessible to the operator and that deliver power are to be overloaded.	See appended table 5.3.	P
	During abnormal operating testing, if a circuit is interrupted by the opening of a component, the test shall be repeated twice (three tests total) using new components as necessary.		N/A
6.4	Equipment intended for connection to telecommunication network outside plant cable is required to be protected against overvoltage from power line crosses in accordance with 6.4 and Annex NAC.		N/A
Annex EE	UL articulated accessibility probe (Fig EE.3) required for assessing accessibility to document/media shredders instead of the Figure 2A test finger.		N/A
Annex M.2	Continuous ringing signals up to 16 mA only are permitted if the equipment is subjected to special installation and performance restrictions.		N/A
Annex NAD	Equipment connected to a telecommunication and cable distribution networks and supplied with an earphone intended to be held against, or in the ear is required to comply with special acoustic pressure requirements.		N/A

Attachments

Photographs

Supplement ID	Description
2-01	Overall View-1 for Model FD9387-EHTV
2-02	Overall View-2 for Model FD9387-EHTV
2-03	Overall View-3 for Model FD9387-EHTV
2-04	Overall View-4 for Model FD9387-EHTV
2-05	Overall View-5 for Model FD9387-EHV
2-06	Overall View-6 for Model FD9387-EHV
2-07	Overall View-7 for Model FD9387-EHV
2-08	Overall View-8 for Model FD9387-EHV
2-09	Overall View-9 for Model FD9387-HTV
2-10	Overall View-10 for Model FD9387-HTV
2-11	Overall View-11 for Model FD9387-HTV
2-12	Overall View-12 for Model FD9387-HTV
2-13	Overall View-13 for Model FD9387-HV, FD9387-HVTPM
2-14	Overall View-14 for Model FD9387-HV, FD9387-HVTPM
2-15	Overall View-15 for Model FD9387-HV, FD9387-HVTPM
2-16	Overall View-16 for Model FD9387-HV, FD9387-HVTPM
2-17	Overall View-17 for Model FD9187-HT
2-18	Overall View-18 for Model FD9187-HT
2-19	Overall View-19 for Model FD9187-HT
2-20	Overall View-20 for Model FD9187-HT
2-21	Overall View-21 for Model FD9187-H
2-22	Overall View-22 for Model FD9187-H
2-23	Overall View-23 for Model FD9187-H
2-24	Overall View-24 for Model FD9187-H
2-25	Internal View-1 for Model FD9387-EHTV
2-26	Internal View-2 for Model FD9387-EHTV
2-27	Internal View-3 for Model FD9387-EHTV
2-28	Internal View-4 for Model FD9387-EHV
2-29	Internal View-5 for Model FD9387-HTV
2-30	Internal View-6 for Model FD9387-HV, FD9387-HVTPM
2-31	Internal View-7 for Model FD9187-HT

2-32	Internal View-8 for Model FD9187-H
2-33	Internal View-9 for Model FD9387-EHTV
2-34	Internal View-10 for Model FD9387-EHTV
2-35	Main board top View-1 for Model FD9387-EHTV, FD9387-EHV
2-36	Main board bottom View-2 for Model FD9387-EHTV, FD9387-EHV
2-37	Main board top View-3 for Model FD9387-HTV, FD9387-HV, FD9387-HVTPM
2-38	Main board top View-4 for Model FD9387-HTV, FD9387-HV, FD9387-HVTPM
2-39	Main board top View-5 for Model FD9187-HT, FD9187-H
2-40	Main board bottom View-6 for Model FD9187-HT, FD9187-H
2-41	IR LED board View-1 for Model FD9387-EHTV, FD9387-HTV, FD9187-HT
2-42	IR LED board View-2 for Model FD9387-EHTV, FD9387-HTV, FD9187-HT
2-43	IR LED board View-3 for Model FD9387-EHV, FD9387-HV, FD9387-HVTPM, FD9187-H
2-44	IR LED board View-4 for Model FD9387-EHV, FD9387-HV, FD9387-HVTPM, FD9187-H
2-45	Sensor board View-1 for All Model
2-46	Sensor board View-2 for All Model

Photographs ID 2-01



Photographs ID 2-02



Photographs ID 2-03



Photographs ID 2-04

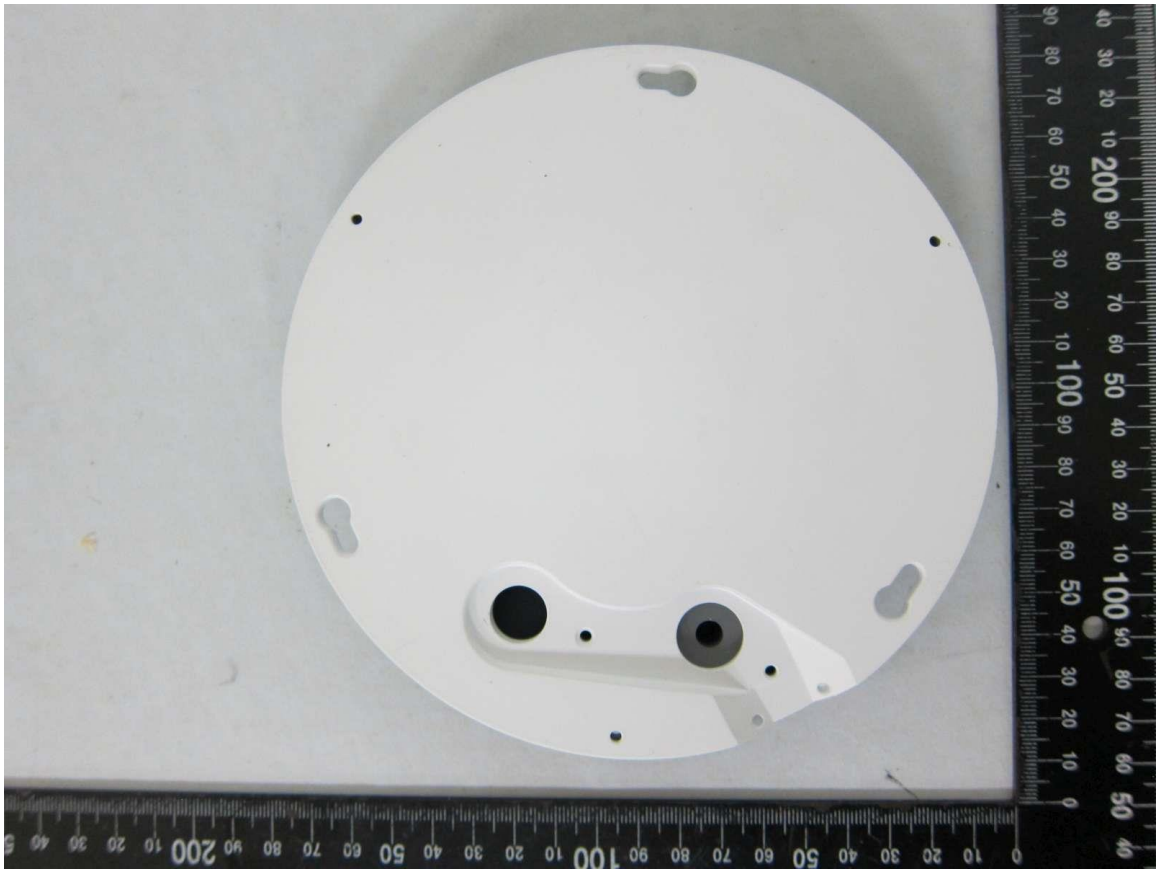

Photographs ID 2-05



Photographs ID 2-06



Photographs ID 2-07



Photographs ID 2-08

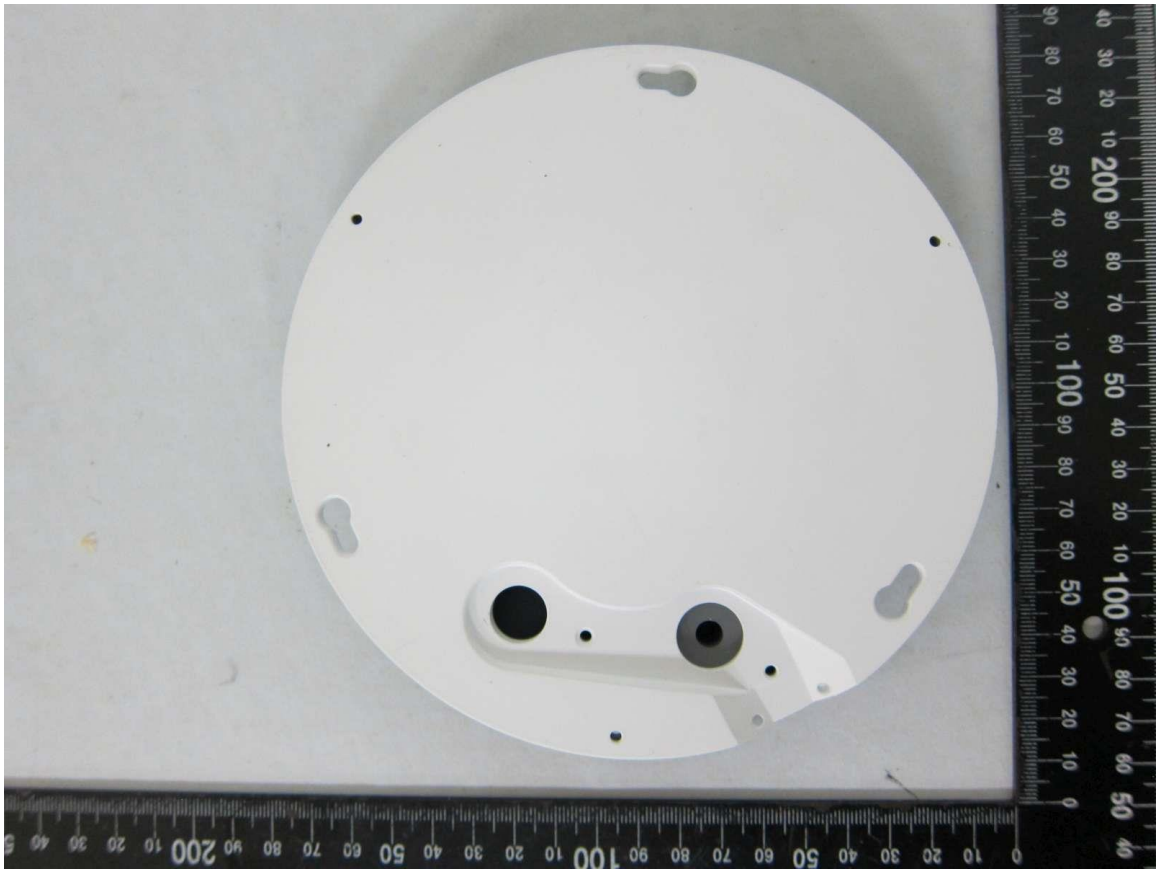

Photographs ID 2-09



Photographs ID 2-10

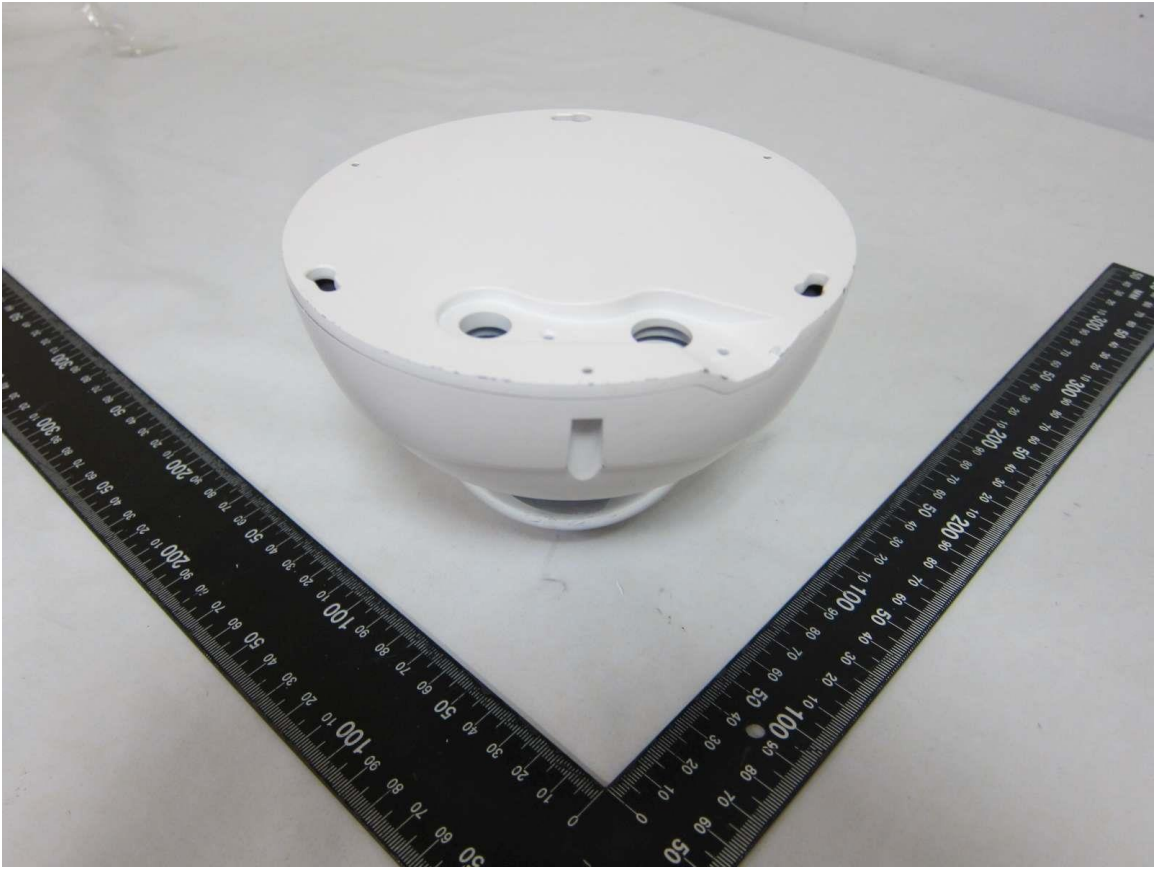

Photographs ID 2-11



Photographs ID 2-12

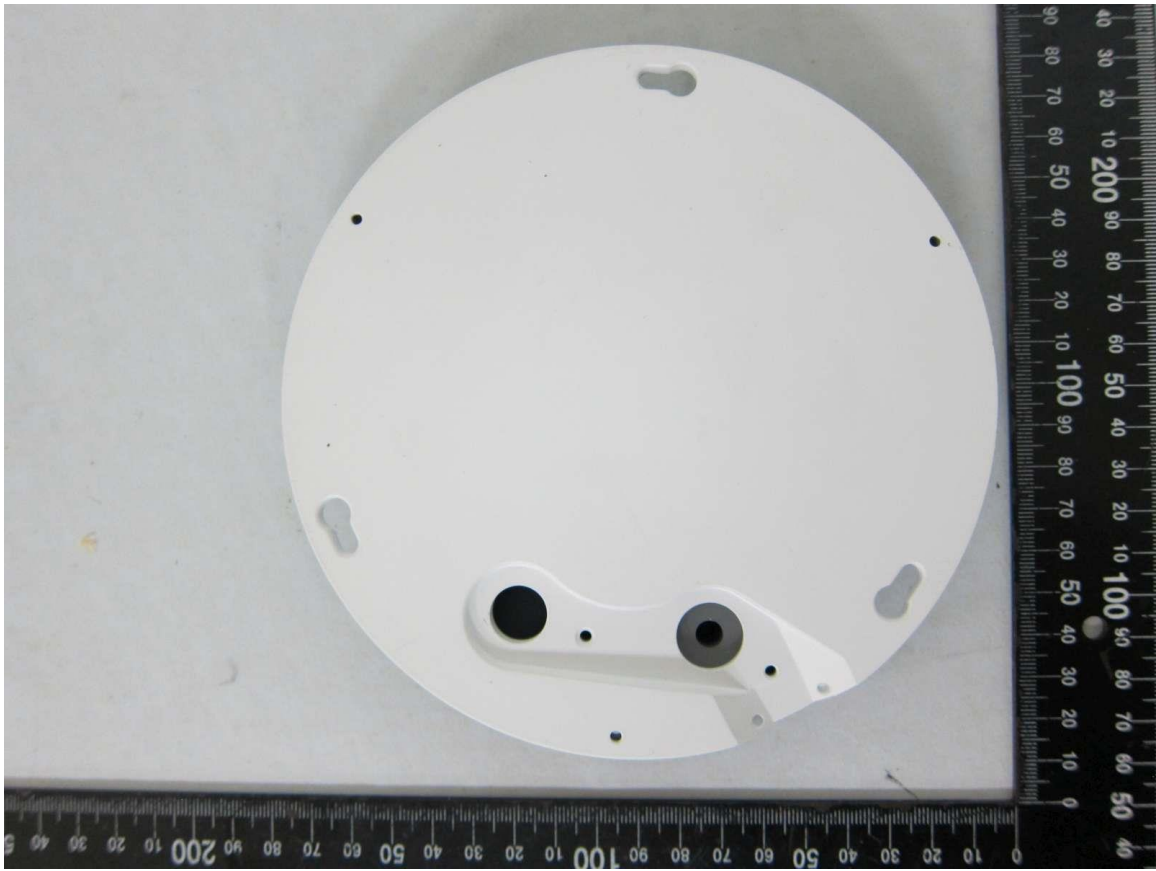

Photographs ID 2-13



Photographs ID 2-14

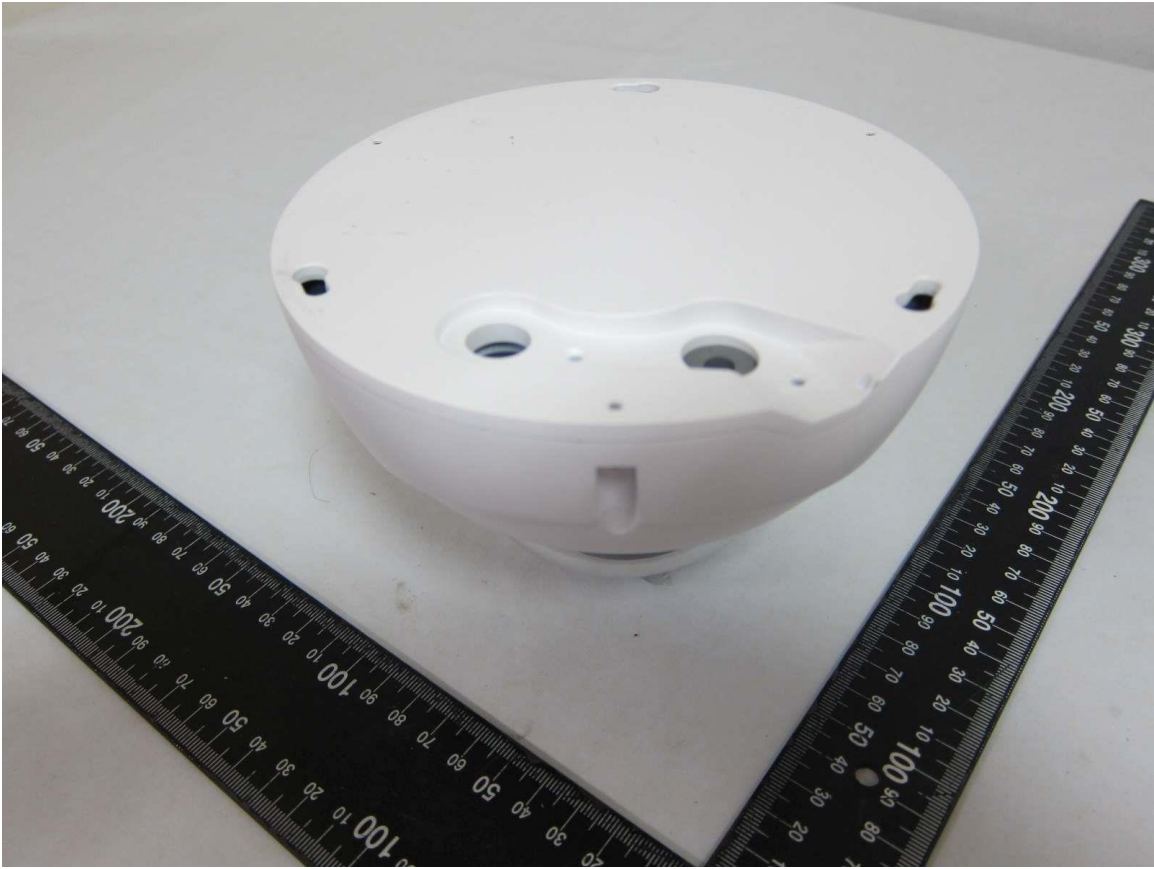

Photographs ID 2-15



Photographs ID 2-16

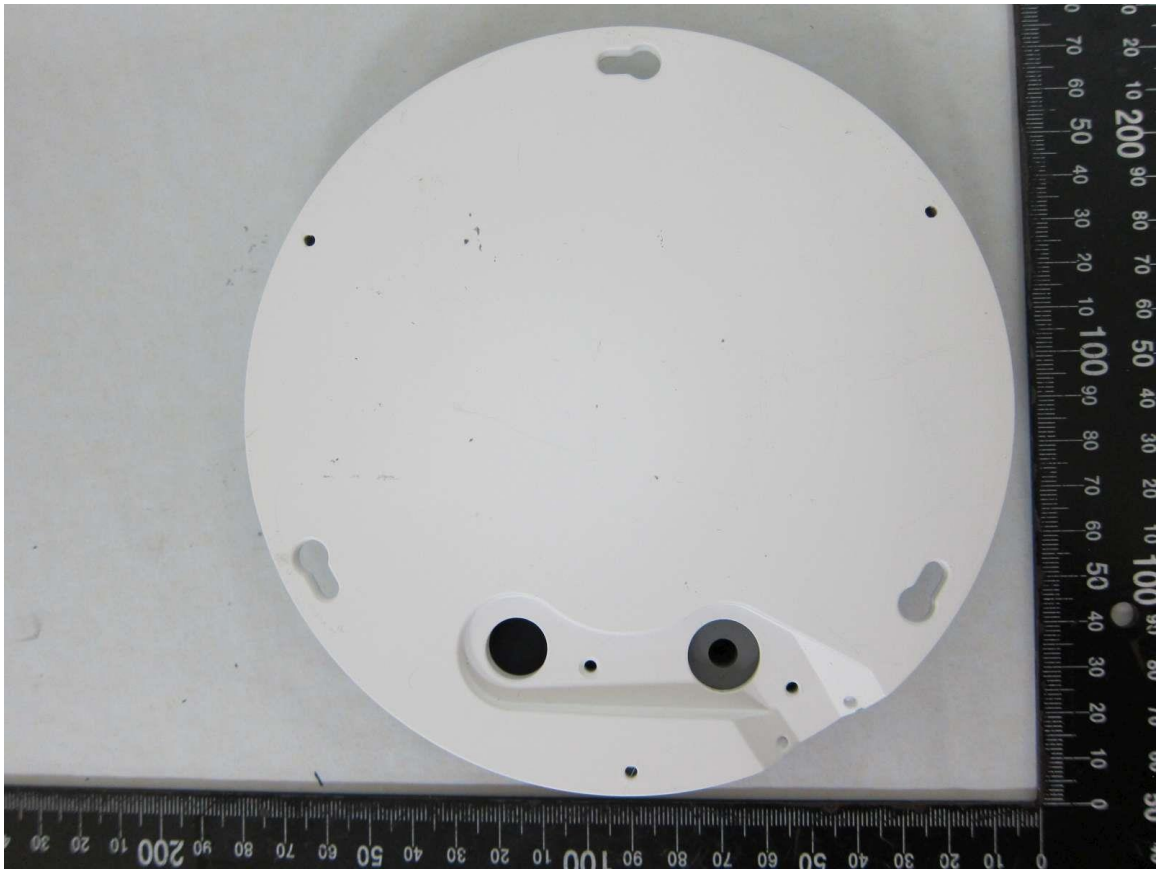

Photographs ID 2-17



Photographs ID 2-18

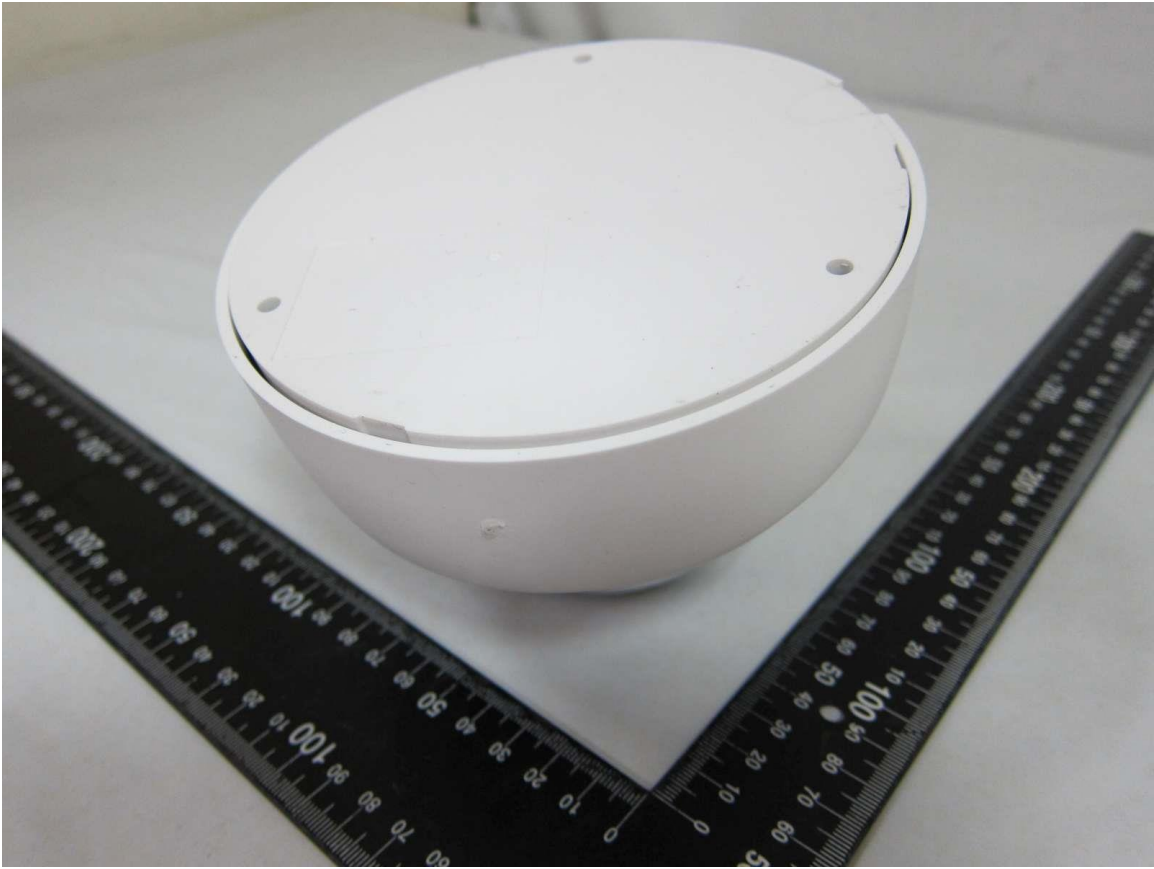

Photographs ID 2-19



Photographs ID 2-20

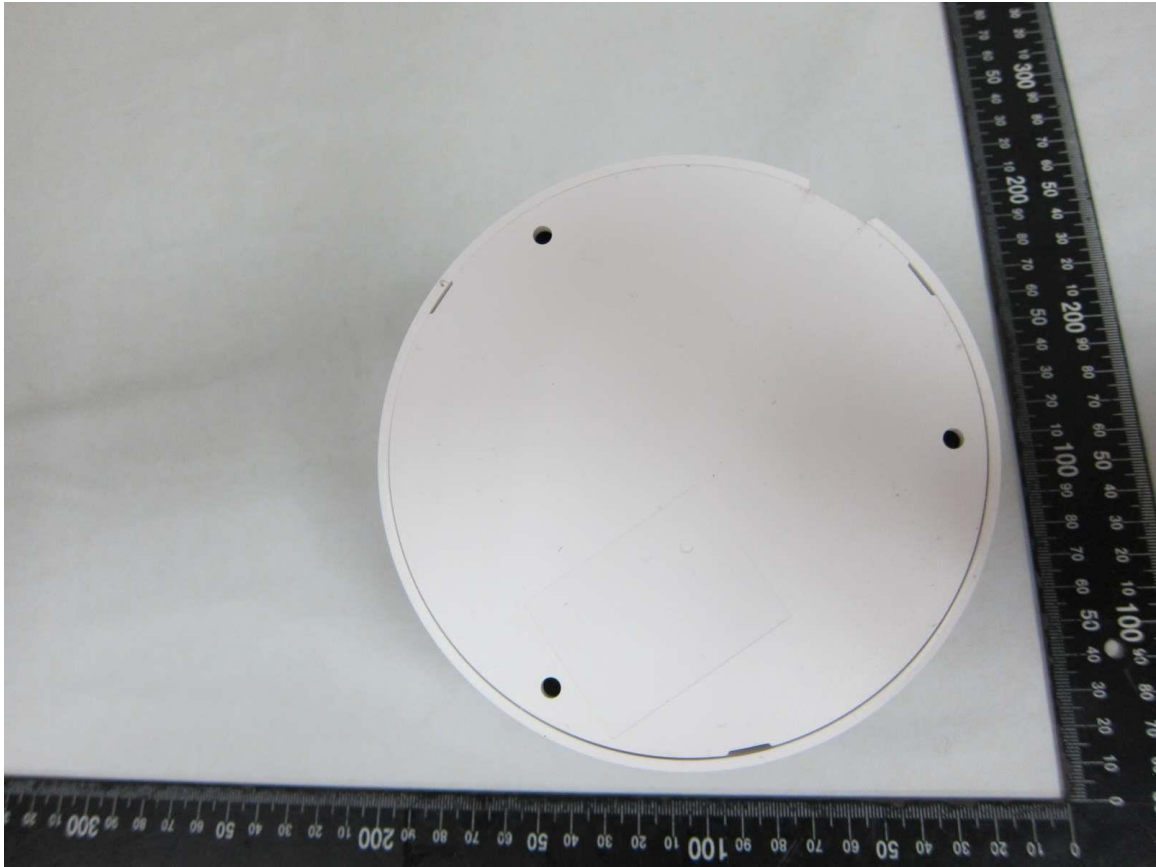

Photographs ID 2-21



Photographs ID 2-22

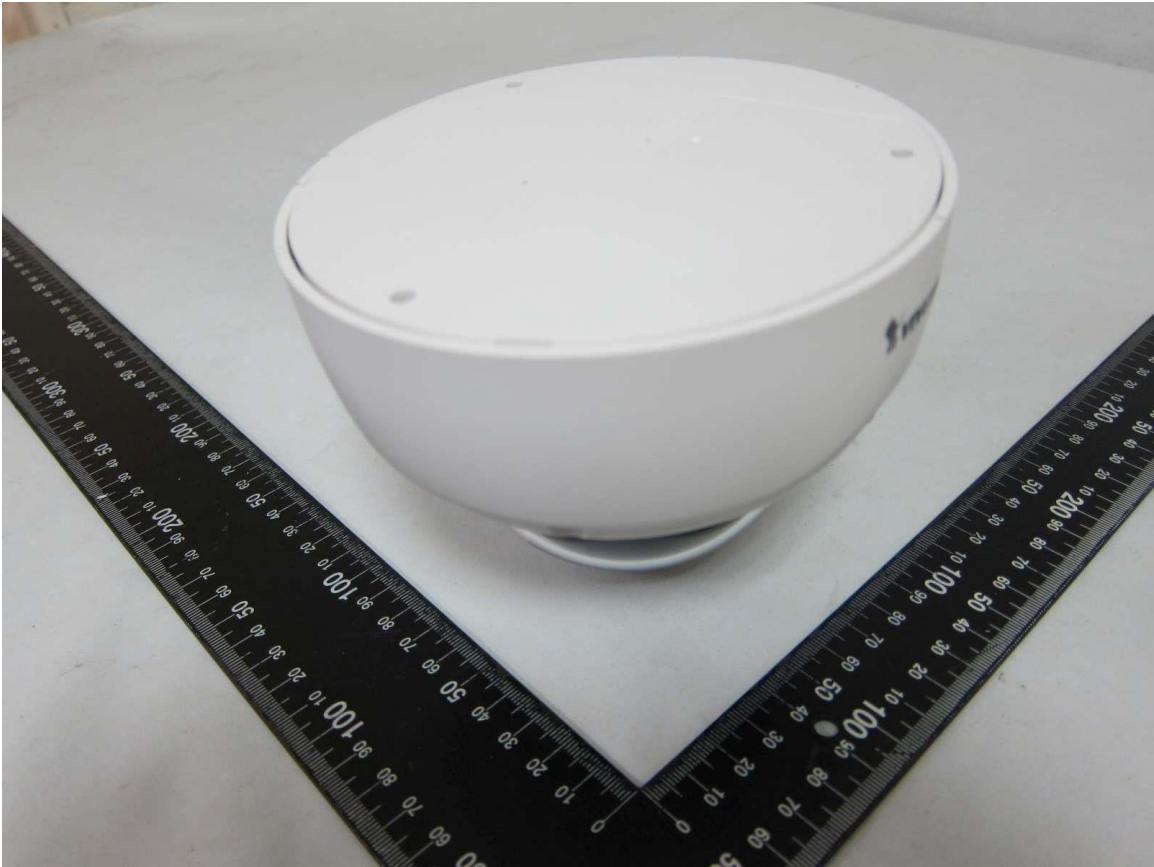

Photographs ID 2-23



Photographs ID 2-24

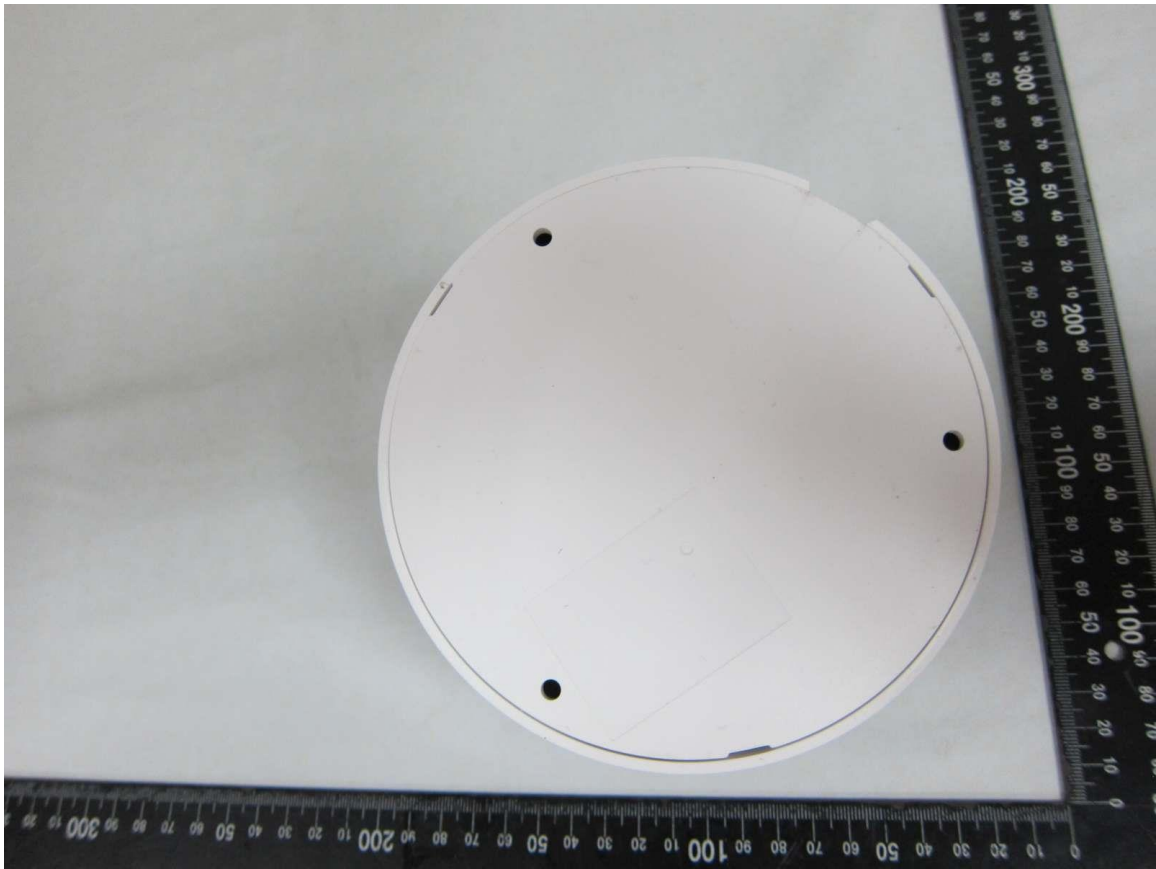

Photographs ID 2-25



Photographs ID 2-26



Photographs ID 2-27

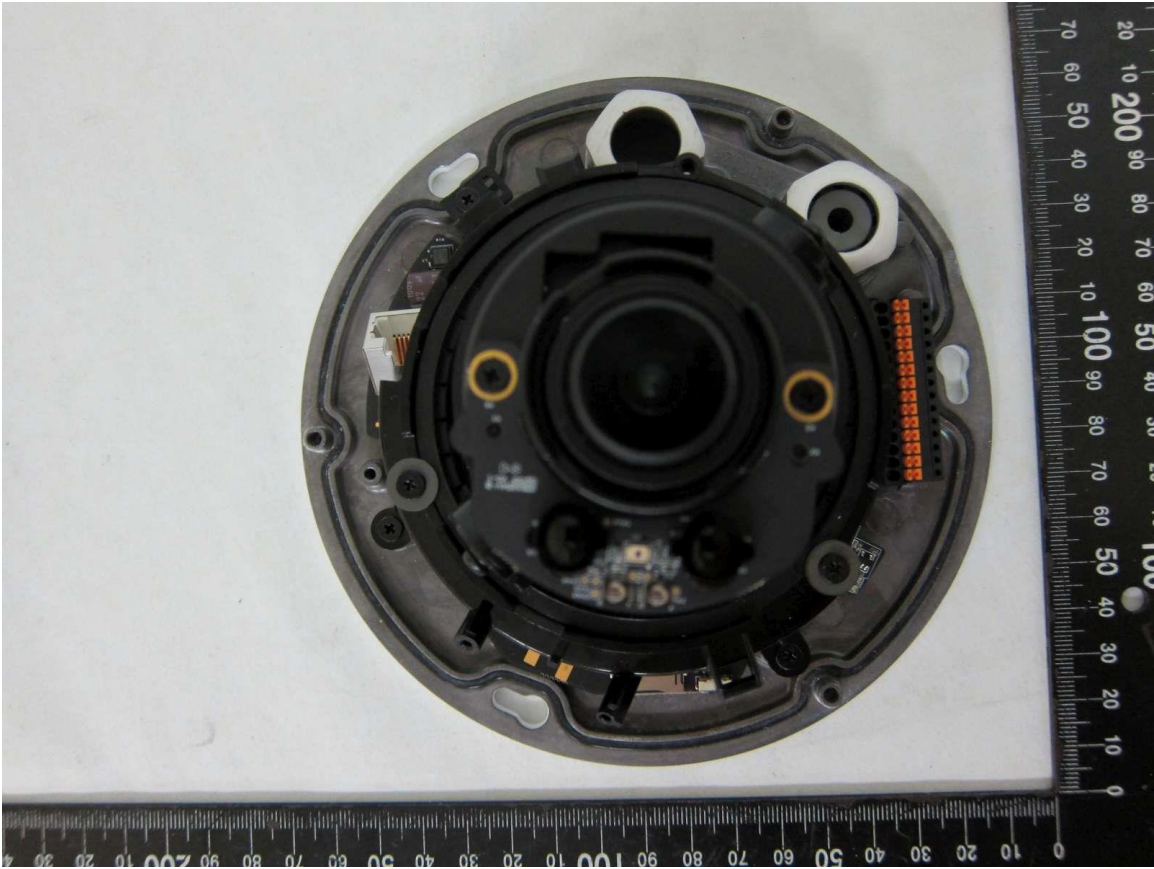

Photographs ID 2-28



Photographs ID 2-29



Photographs ID 2-30

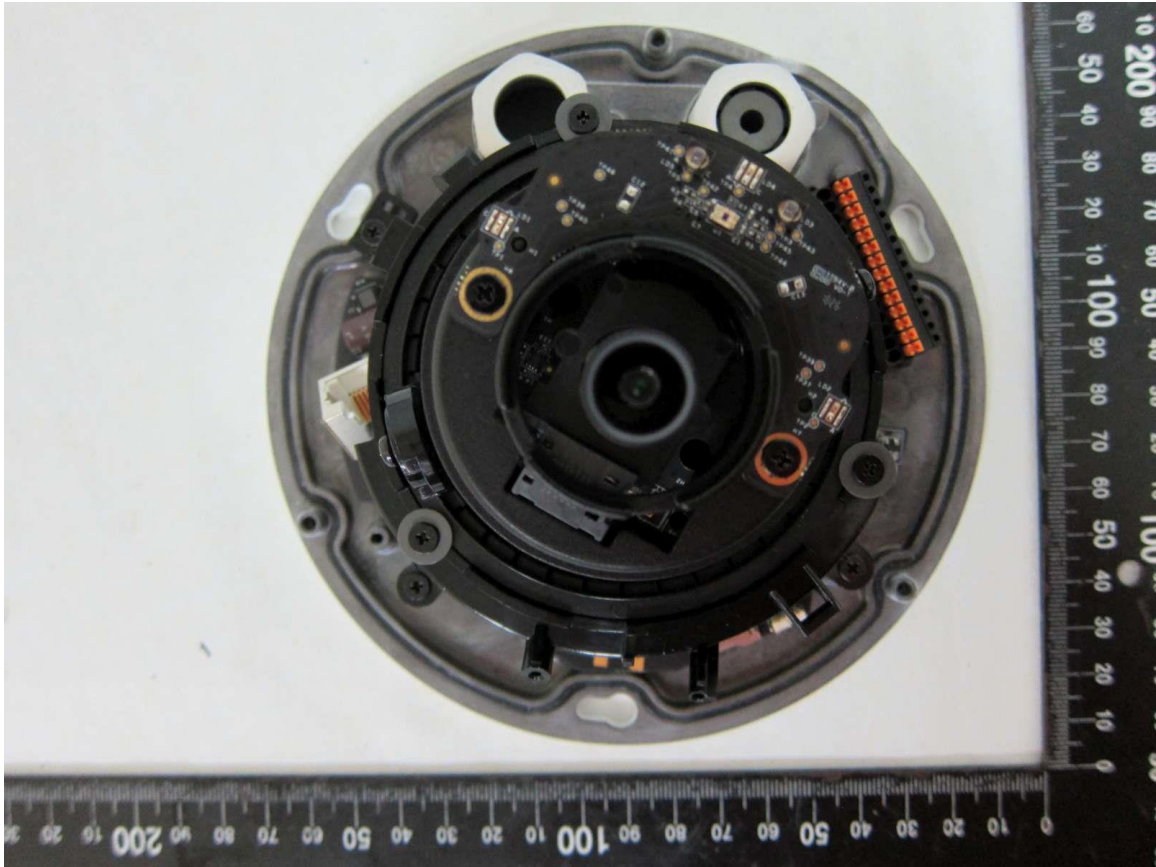

Photographs ID 2-31

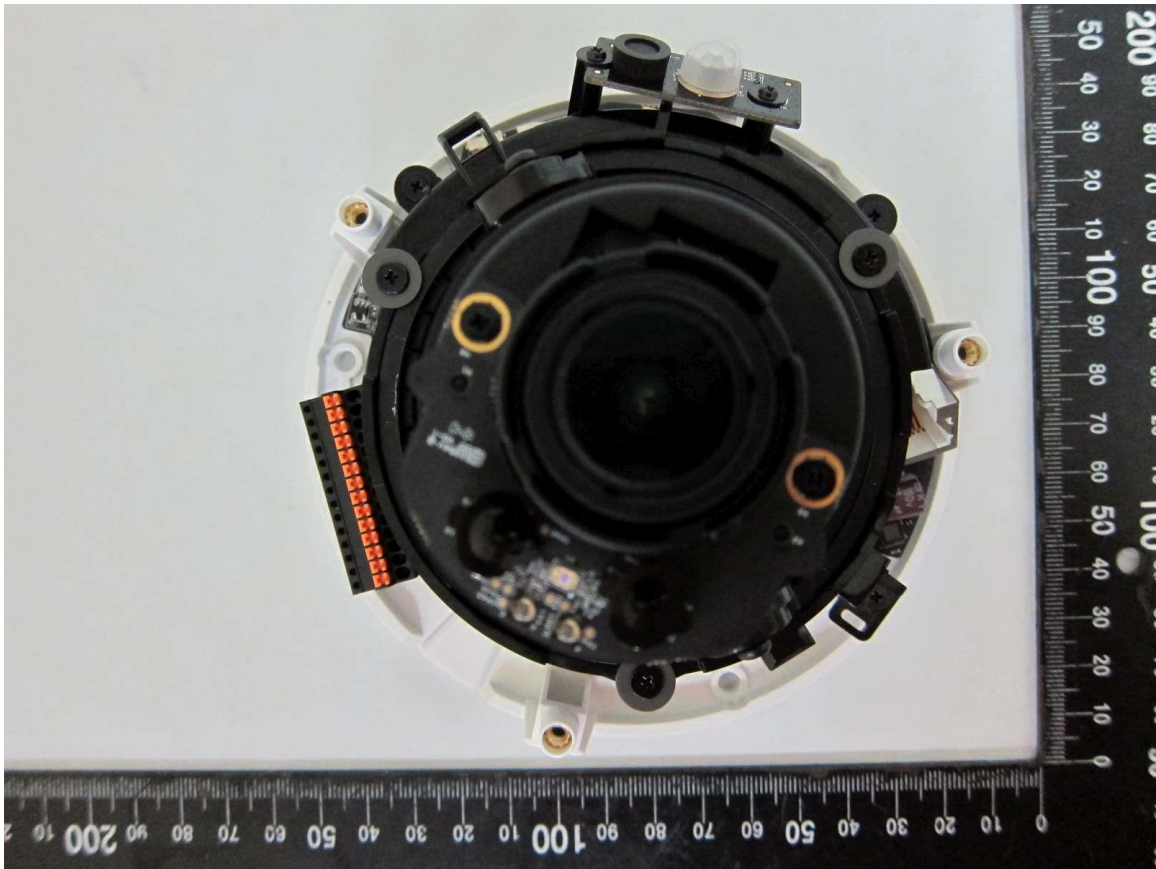

Photographs ID 2-32



Photographs ID 2-33

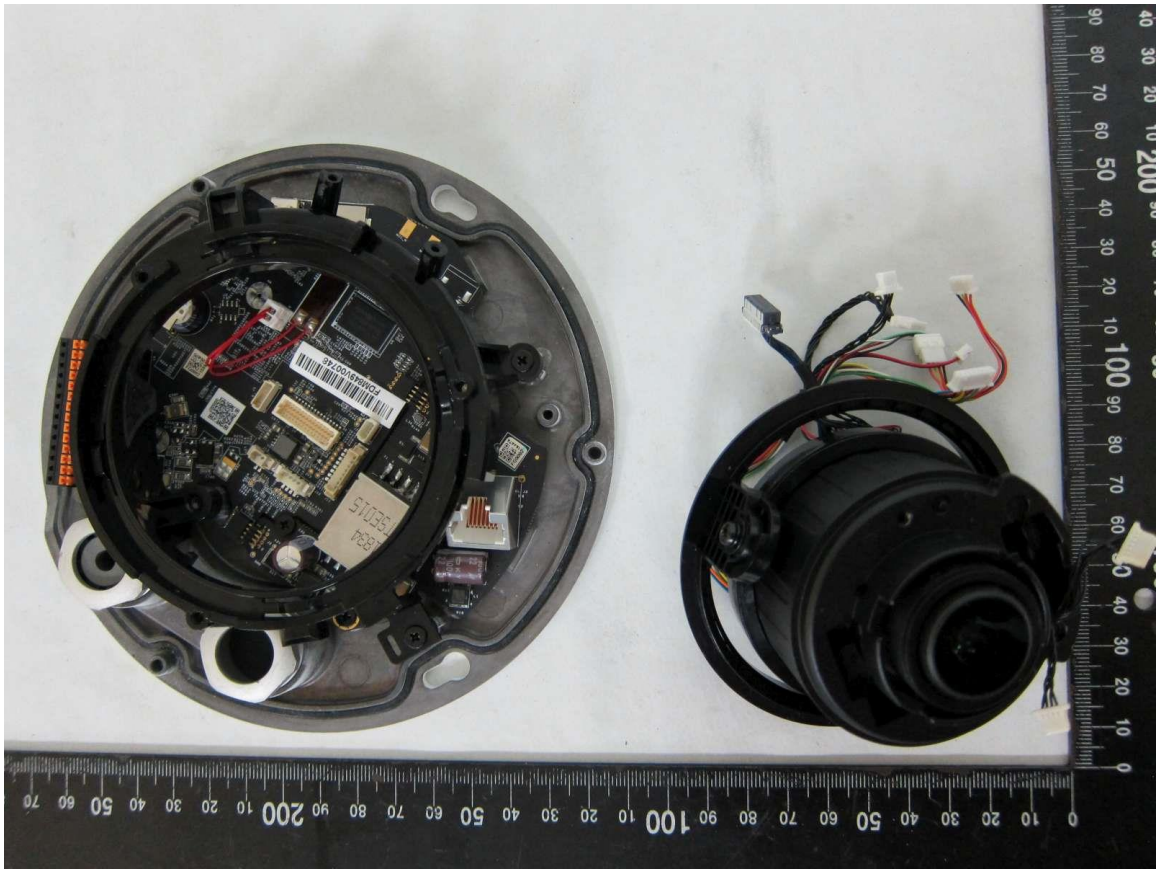

Photographs ID 2-34

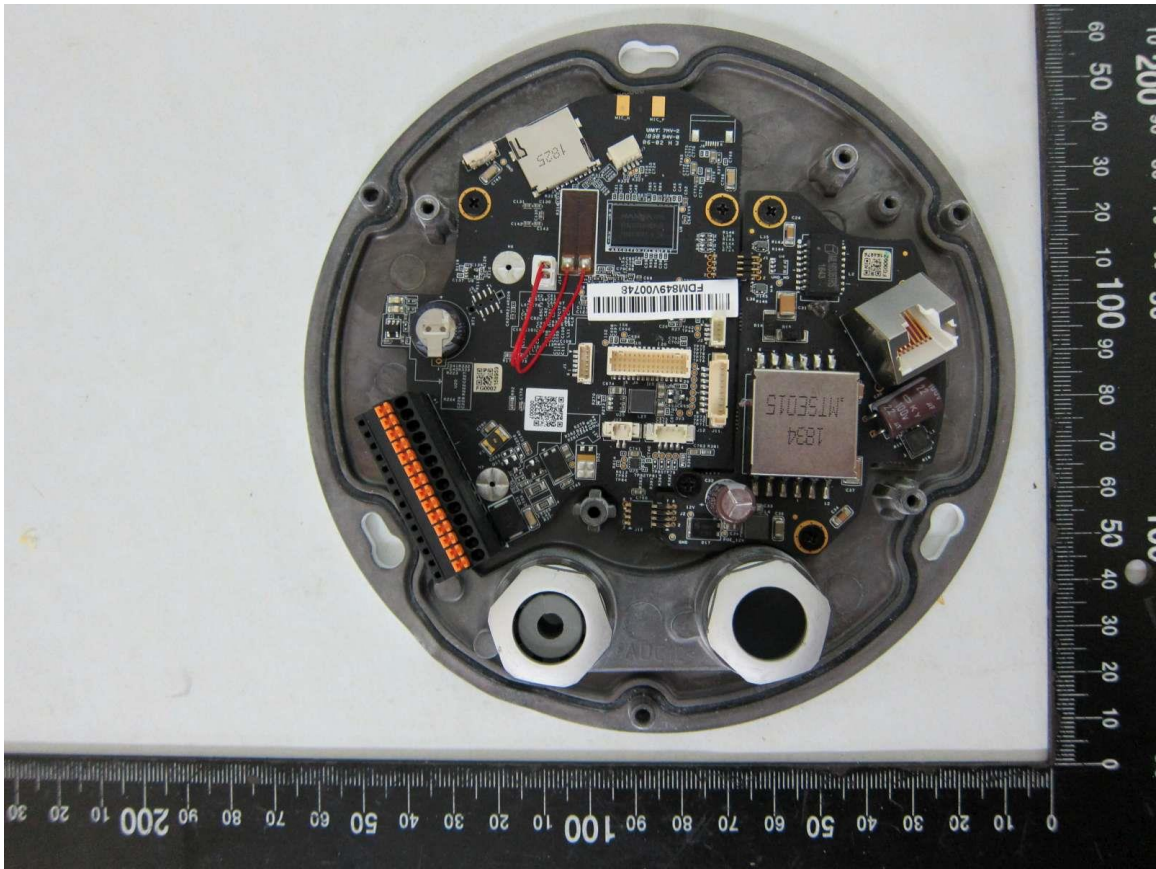

Photographs ID 2-35

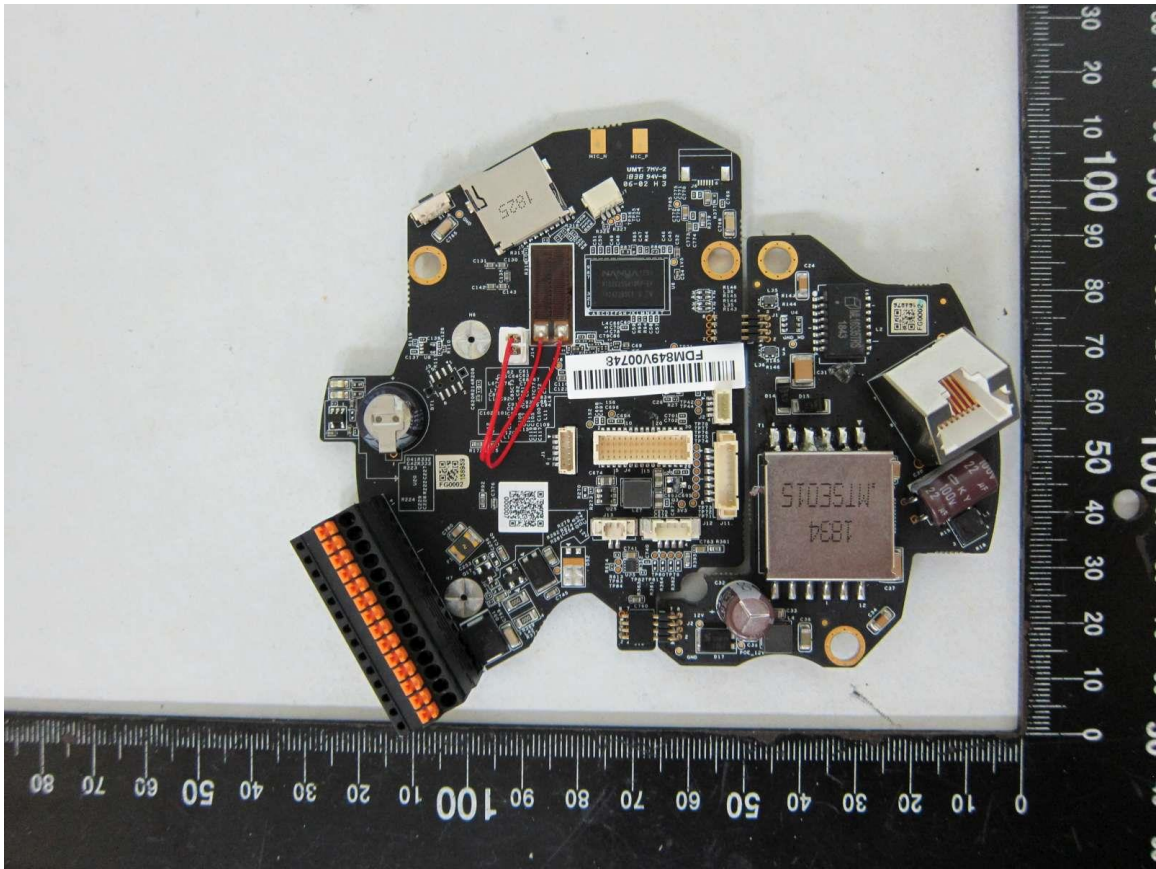

Photographs ID 2-36

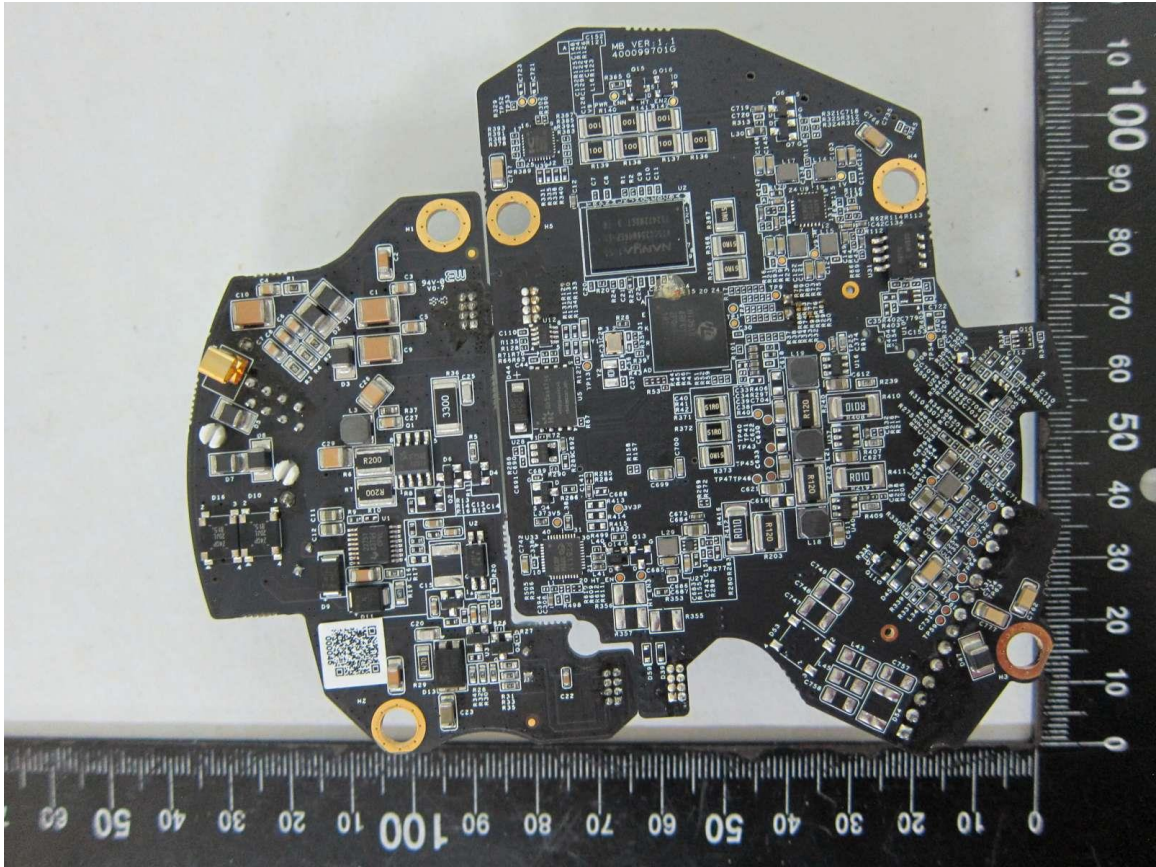

Photographs ID 2-37

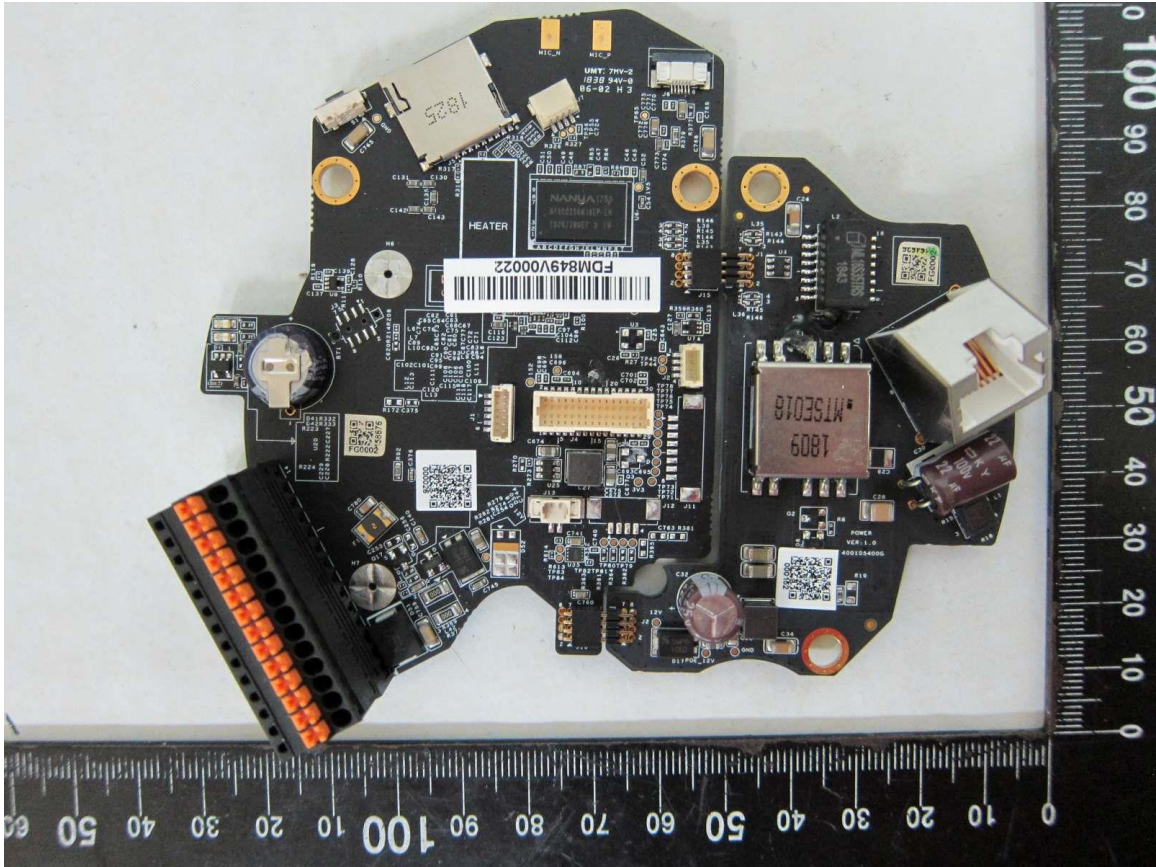

Photographs ID 2-38

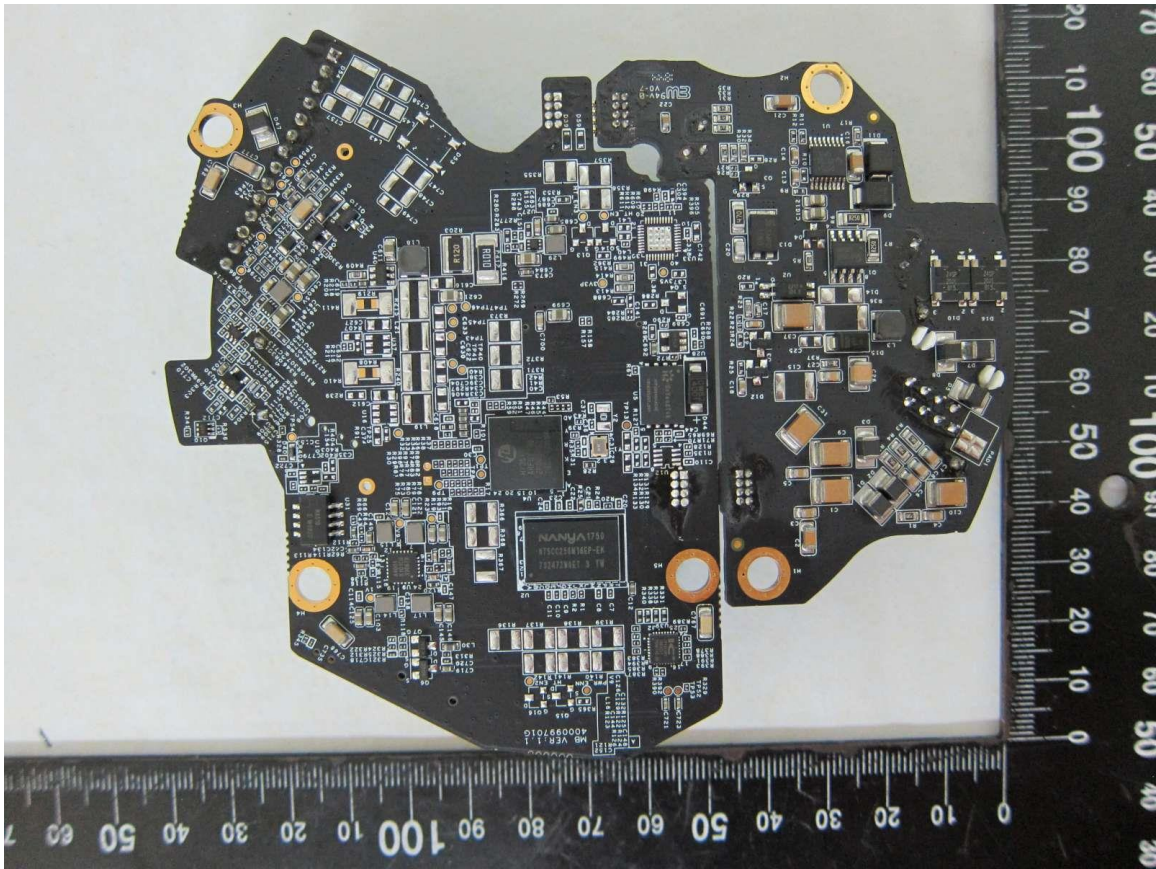

Photographs ID 2-39

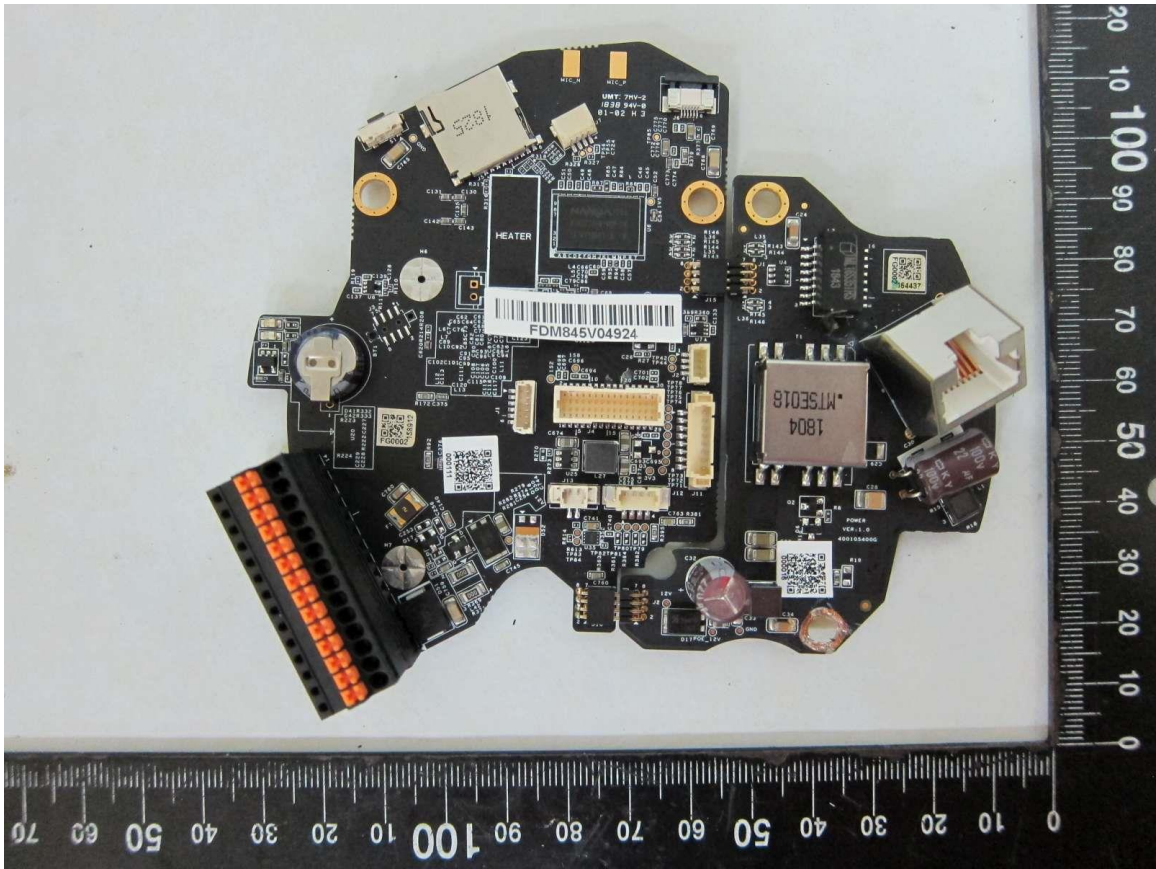

Photographs ID 2-40

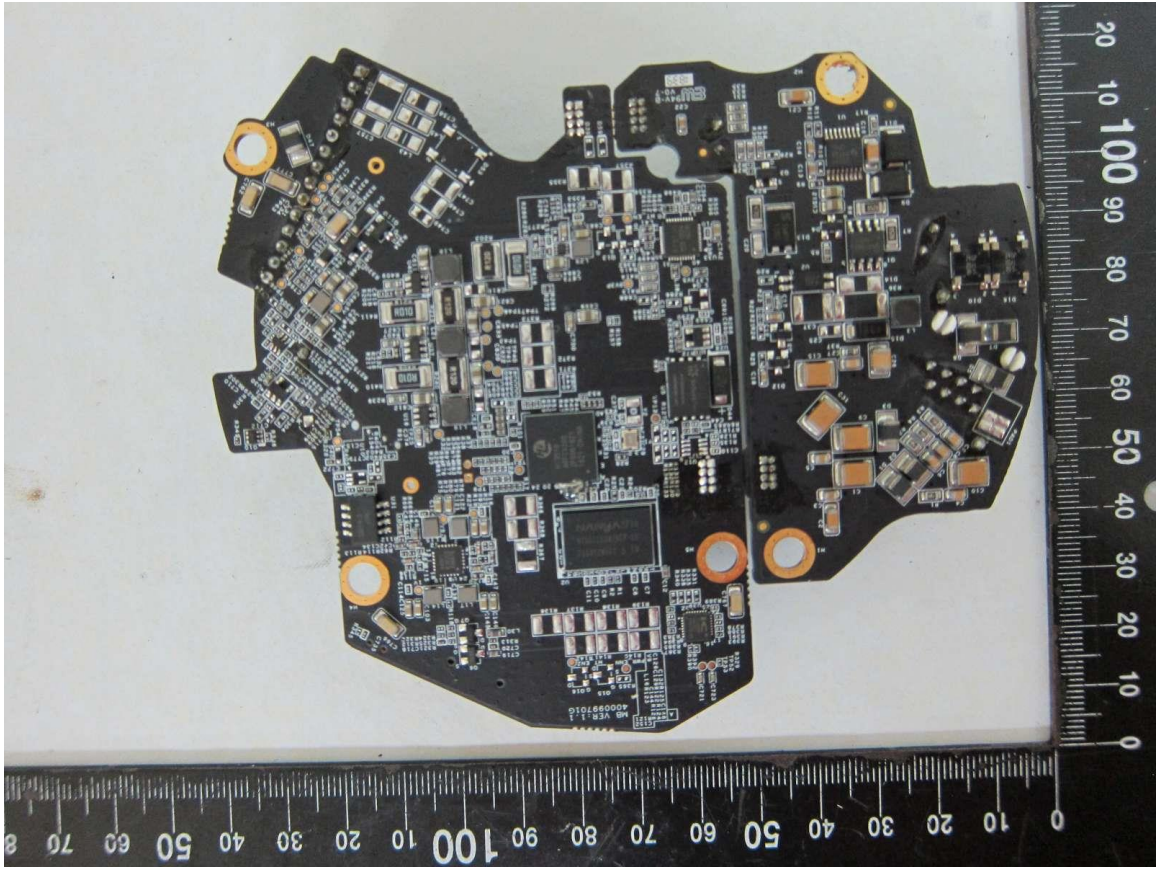

Photographs ID 2-41

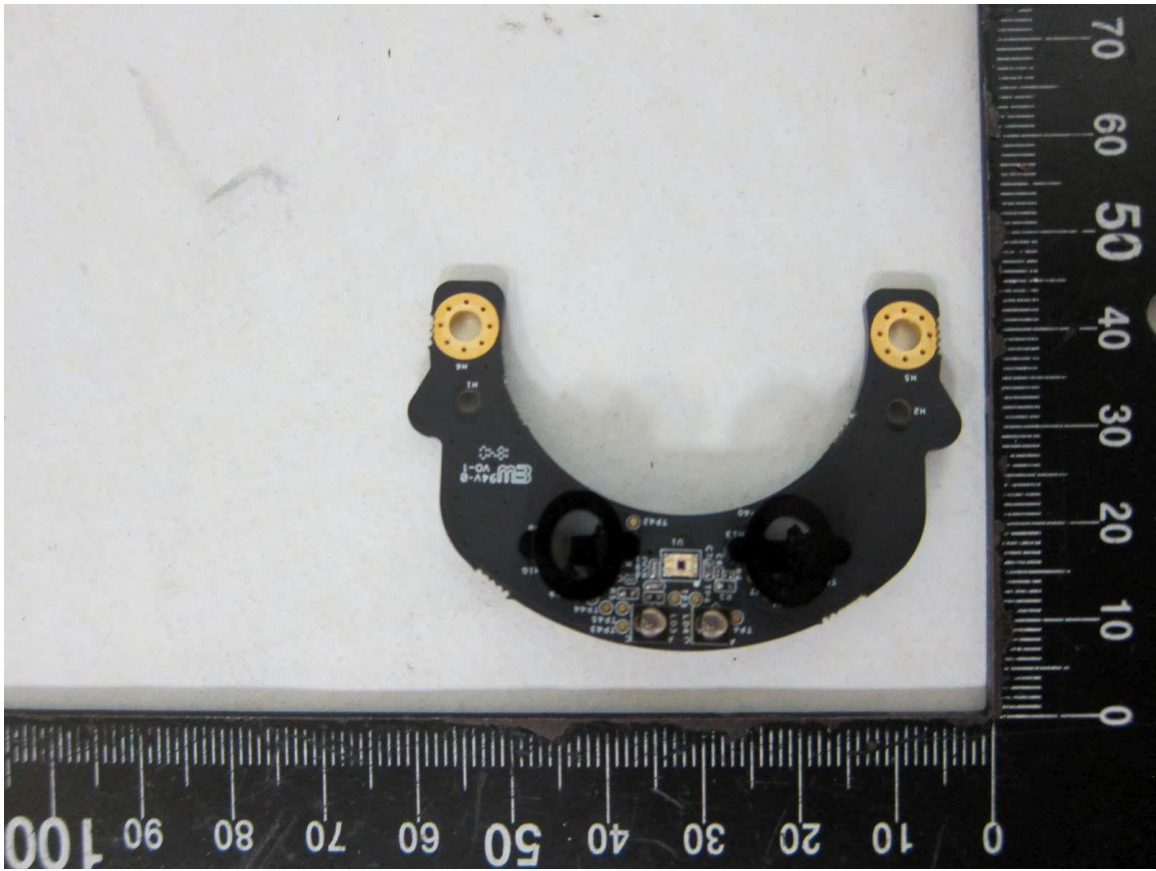

Photographs ID 2-42

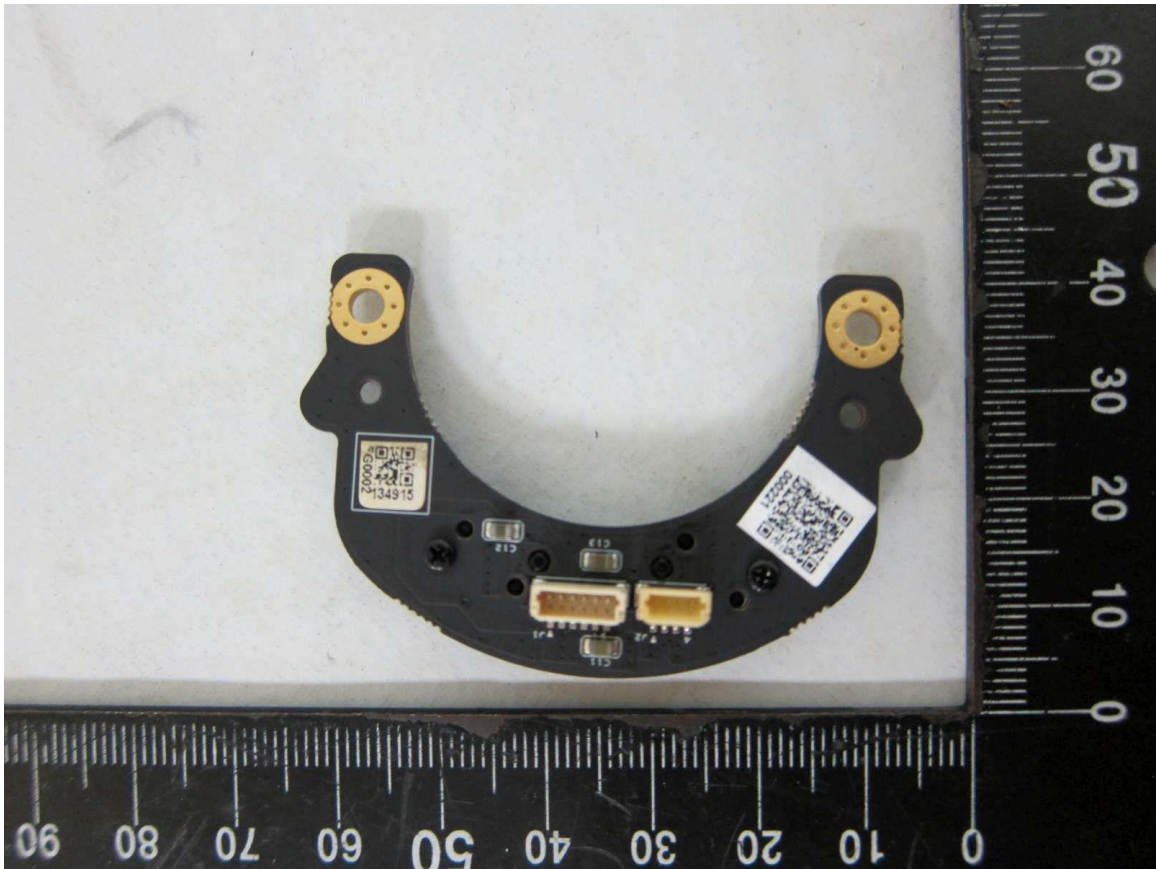

Photographs ID 2-43



Photographs ID 2-44



Photographs ID 2-45

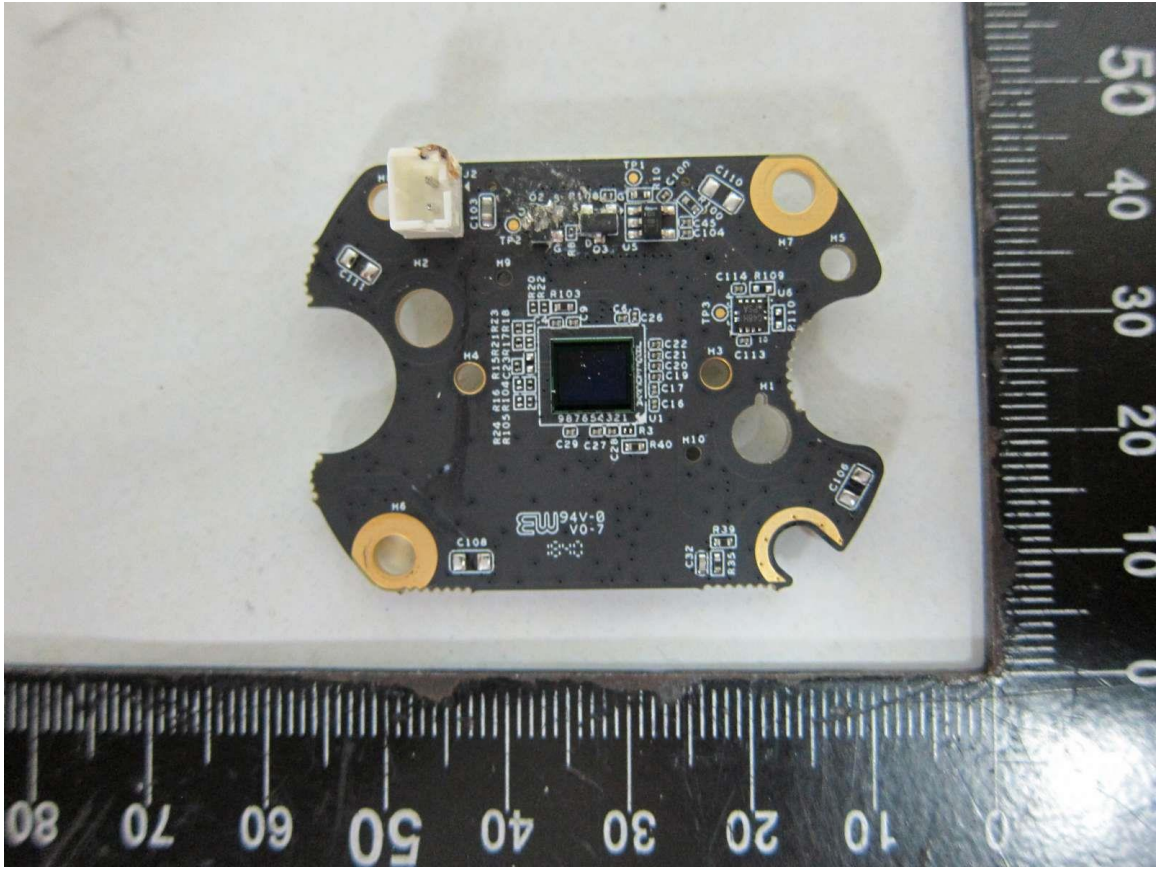

Photographs ID 2-46

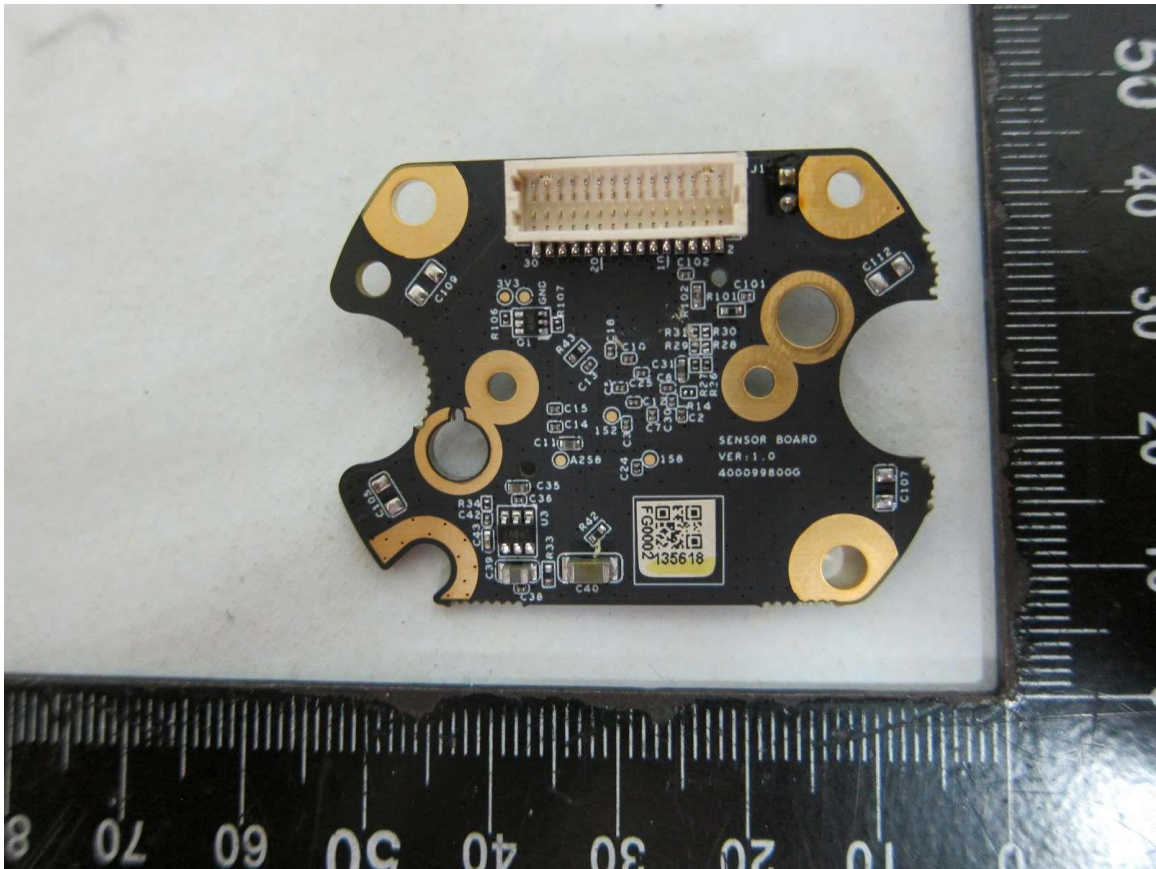

Attachments

Diagrams

Supplement ID	Description
3-01	O-ring drawing (Between plastic lens cover and metal enclosure)
3-02	O-ring drawing (Between top enclosure and bottom enclosure)
3-03	Gasket for Cable Glands(Hole of LAN cable)
3-04	Gasket of Cable Glands (for I/O terminal), if cable is not provided.

Diagrams ID 3-01

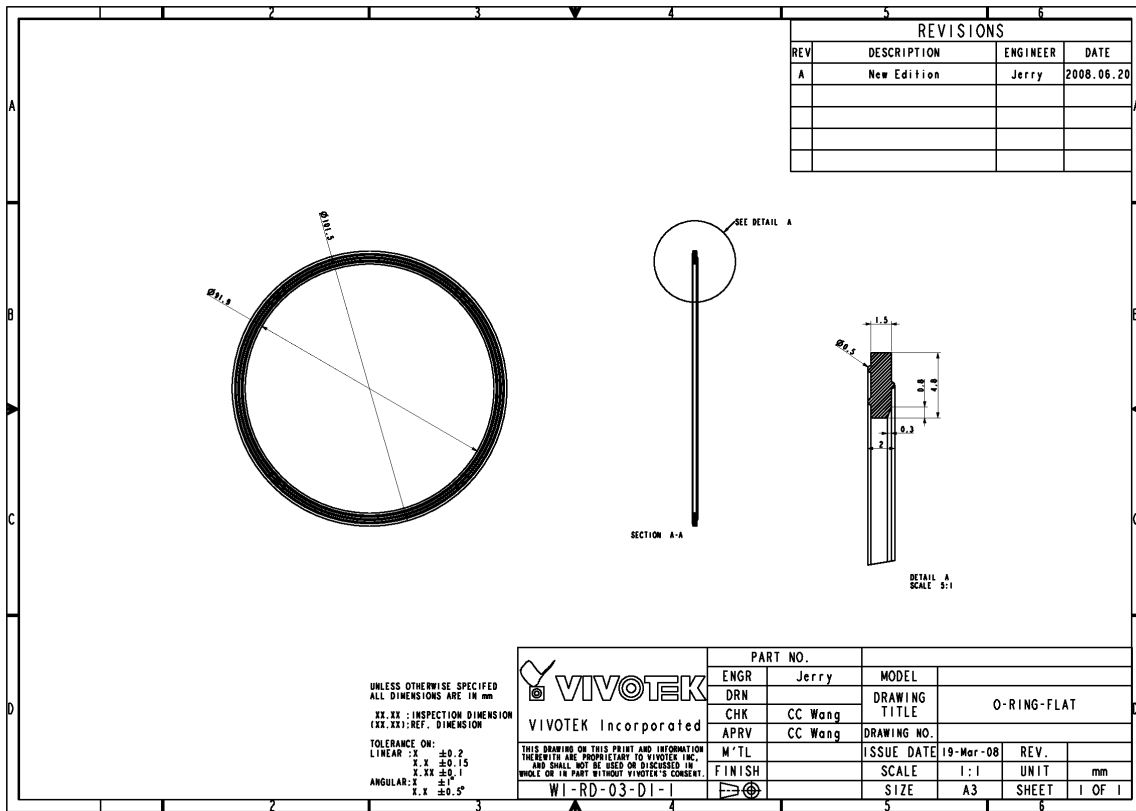

Diagrams ID 3-02

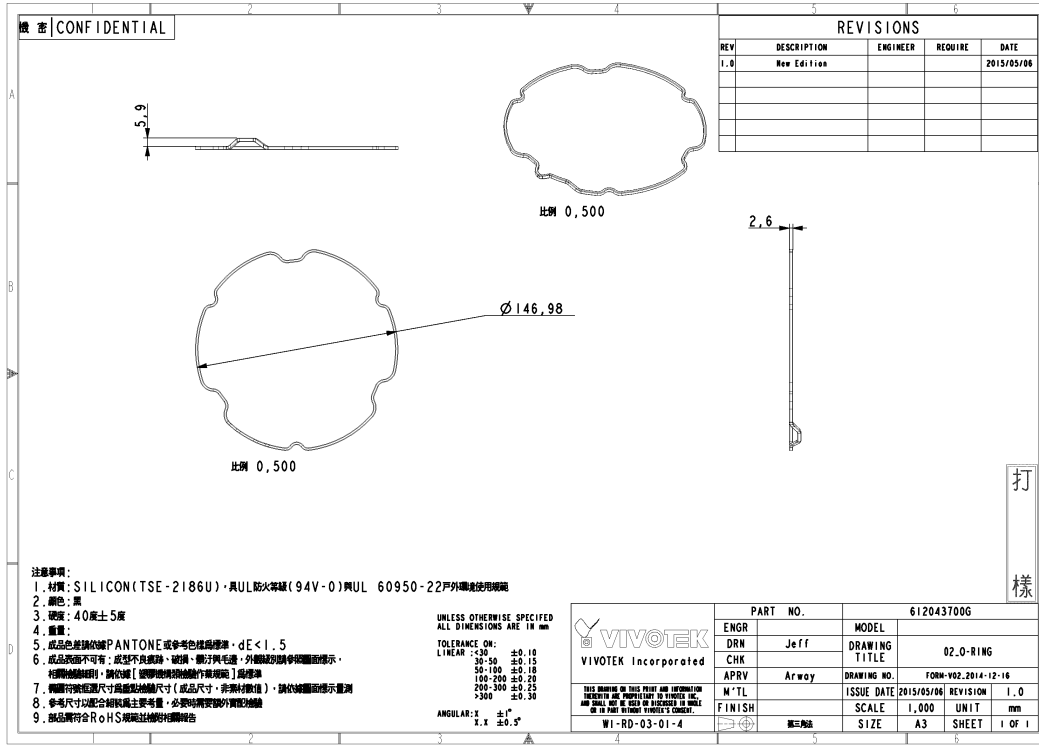

Diagrams ID 3-03

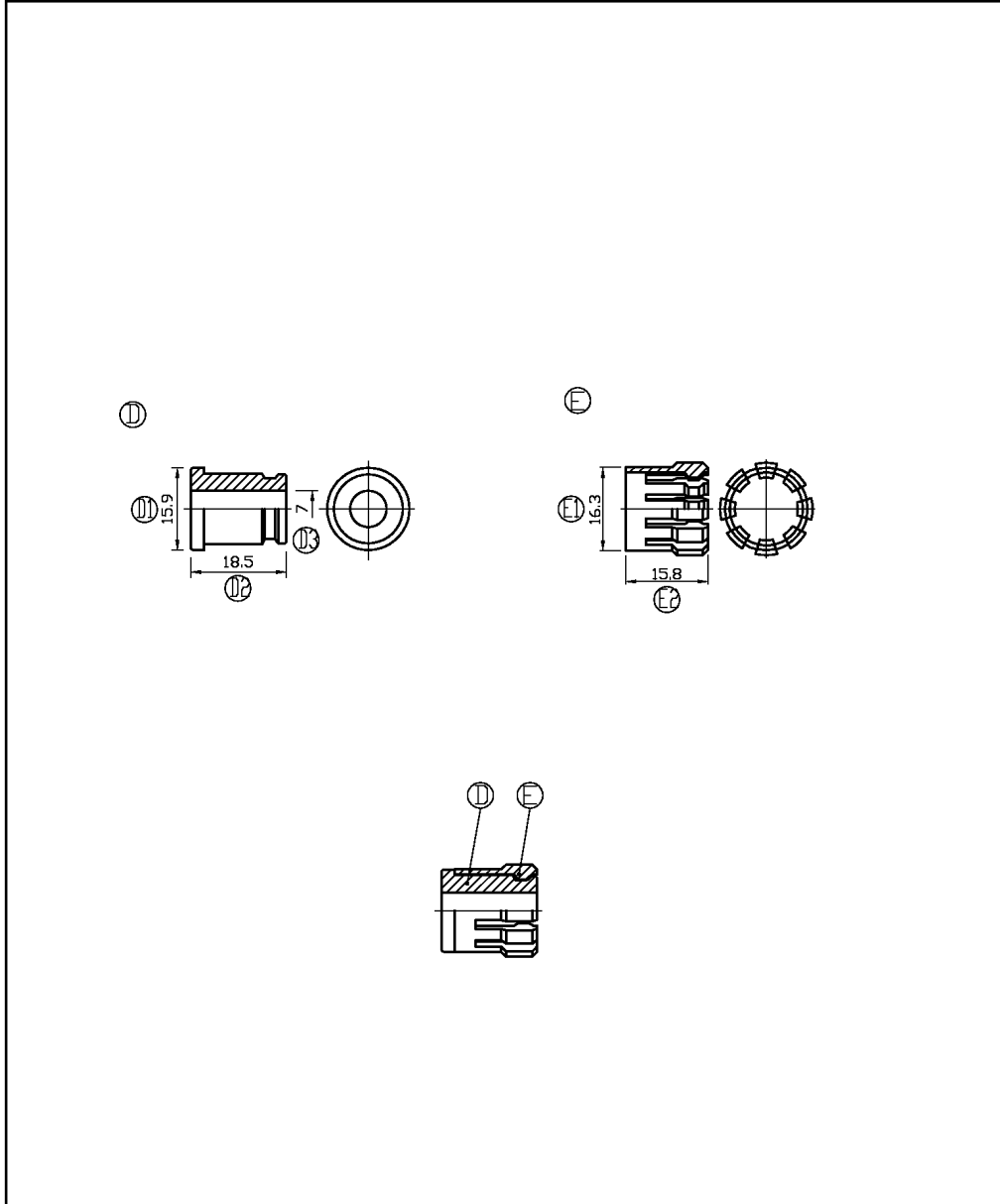

Confidential 機密文件 非授權 請勿外流

AVC 全冠企業有限公司 AVC Industrial Corp.			INSPECTED BY YAWEN	2014.09.19	TOLERANCE: 6 ±0.2 18.1-30±0.5 8.1-9±0.3 30.1-50±0.6 9.1-18±0.4 50.1-80±0.8 REMARK: All rights reserved () Inside reference value	PATENTED
PRODUCT: NYLON CABLE GLANDS			DRAWN BY LING GHIU	2014.09.19		
PART NO.: MG16A-06B-ST-XABCF			MATERIAL D PART:BLACK EPDM E PART:BLACK PA66 UL94V-2	Working Temp. -40°C to 105°C (-40°F to 221°F)		
SCALE: 1:1	UNIT: mm	REV. 7.1		() Inside reference value		



Diagrams ID 3-04

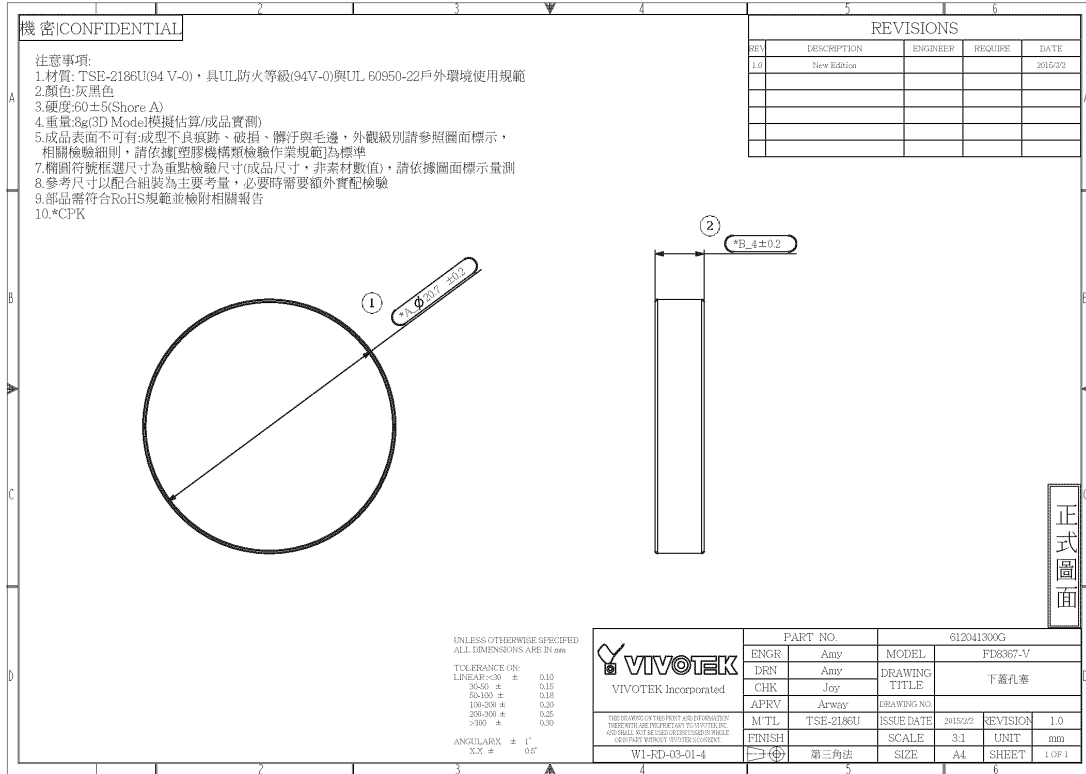

Attachments**Miscellaneous**

Supplement ID	Description
4-01	IEC60950-22 Test report
4-02	IR LED IEC62471 CB report
4-03	IP66 Test report

Miscellaneous ID 4-01



Test Report issued under the responsibility of:



TEST REPORT IEC 60950-22 Information technology equipment Safety – Part 22: Equipment to be installed outdoors	
Report Reference No.	E324690- 4788944424 -1 Original
Date of issue	2019-05-27
Total number of pages	24
CB Testing Laboratory	UNDERWRITERS LABORATORIES TAIWAN CO LTD
Address	260 Da-Yeh Road, TW-112 Peitou Taipei City, Chinese Taipei
Applicant's name	VIVOTEK INC
Address	6F, No.192, LIEN CHENG RD CHUNG HO DISTRICT, NEW TAIPEI 235, TAIWAN
Test specification:	
Standard	IEC 60950-22: 2005 (1 st Edition)
Test procedure	CB / CCA
Non-standard test method	N/A
Test Report Form No.	IEC60950_22A
Test Report Form(s) Originator	The Standards Institution of Israel Ltd.
Master TRF	Dated 2007-03
Copyright © 2007 IEC System for Conformity Testing and Certification of Electrical Equipment (IECEE), Geneva, Switzerland. All rights reserved. This publication may be reproduced in whole or in part for non-commercial purposes as long as the IECEE is acknowledged as copyright owner and source of the material. IECEE takes no responsibility for and will not assume liability for damages resulting from the reader's interpretation of the reproduced material due to its placement and context. If this Test Report Form is used by non-IECEE members, the IECEE/IEC logo and the reference to the CB Scheme procedure shall be removed. This report is not valid as a CB Test Report unless signed by an approved CB Testing Laboratory and appended to a CB Test Certificate issued by an NCB in accordance with IECEE 02.	
Test item description	Network Camera
Trade Mark	VIVOTEK
Manufacturer	VIVOTEK INC 6F, No.192, LIEN CHENG RD CHUNG HO DISTRICT, NEW TAIPEI 235, TAIWAN
Model/Type reference	FD9387-EHTV, FD9387-EHV, FD9387-HTV, FD9387-HV, FD9387-HVTPM
Ratings	For Model FD9387-EHTV, FD9387-EHV: 12Vdc, 1.9A; or 42.5~57Vdc, 0.59~0.44A (POE) For Model FD9387-HTV, FD9387-HV, FD9387-HVTPM: 12Vdc, 0.87A; or 37~57Vdc, 0.31~0.2A (POE)

Miscellaneous ID 4-01

Page 2 of 24 Report No. E324690- 4788944424 Original

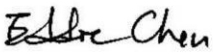
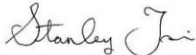
Testing procedure and testing location:	
<input checked="" type="checkbox"/> CB Testing Laboratory:	UNDERWRITERS LABORATORIES TAIWAN CO LTD Testing location/ address: 260 Da-Yeh Road, TW-112 Peitou Taipei City, Chinese Taipei
<input type="checkbox"/> Associated CB Test Laboratory:	Testing location/ address: Tested by (name + signature): Eddie Chen / handler  Approved by (name + signature) : Stanley Tsai / reviewer 
<input type="checkbox"/> Testing procedure: TMP	Tested by (name + signature) : Approved by (+ signature)..... : Testing location/ address :
<input type="checkbox"/> Testing procedure: WMT	Tested by (name + signature) : Witnessed by (+ signature) : Approved by (+ signature)..... : Testing location/ address :
<input type="checkbox"/> Testing procedure: SMT	Tested by (name + signature) : Approved by (+ signature)..... : Supervised by (+ signature) : Testing location/ address :
<input type="checkbox"/> Testing procedure: RMT	Tested by (name + signature) : Approved by (+ signature)..... : Supervised by (+ signature) : Testing location/ address :

Miscellaneous ID 4-01

Page 3 of 24 Report No. E324690- 4788944424 Original

<p>Summary of testing:</p> <ul style="list-style-type: none"> - The manufacturer submitted representative production sample of Network Camera, Model FD9387-EHTV, FD9387-EHV, FD9387-HTV, FD9387-HV, FD9387-HVTPM - The unit was considered exposed SELV circuit. - The following tests were conducted according to CSA C22.2 NO. 60950-22-07 Edition 1, Revision Date 2011/12/01 & UL 60950-22 Edition 1, Revision Date 2011/12/19. <p>4.2.5, 4.2.1, PART 22 10.2 – IMPACT TEST PART 22 9.1, ANNEX B – WATER SPRAY TEST PART 22, 8.5, ANNEX D.2 – TENSILE STRENGTH AND ELONGATION</p>	
<p>Tests performed (name of test and test clause):</p> <p>STRENGTH AND ELONGATION 4.2.5, 4.2.1, PART 22 10.2 – IMPACT TEST PART 22 9.1, ANNEX B – WATER SPRAY TEST PART 22, 8.5, ANNEX D.2 – TENSILE STRENGTH AND ELONGATION</p>	<p>Testing location:</p> <p>UNDERWRITERS LABORATORIES TAIWAN CO LTD/ 260 Da-Yeh Road, TW-112 Peitou Taipei City, Chinese Taipei</p>
<p>Summary of compliance with National Differences:</p> <p>Countries outside the CB Scheme membership may also accept this report. List of countries addressed: CA, US, EU. The product fulfils the requirements of: EN 60950-22:2006 +A11:2008.</p>	
<p>Copy of marking plate:</p> <p>The artwork below may be only a draft. The use of certification marks on a product must be authorized by the respective NCBs that own these marks.</p> <p>Refer to IEC 60950-1 Main report</p>	

Miscellaneous ID 4-01

Page 4 of 24 Report No. E324690- 4788944424 Original

Test item particulars	
Temperature range	-50 to 55 degree C for Model FD9387-EHTV and FD9387-EHV; -30 to 55 degree C for Model FD9387-HTV, FD9387-HV, and FD9387-HVTPM
Overvoltage category.....	<input type="checkbox"/> OVC I <input type="checkbox"/> OVC II <input type="checkbox"/> OVC III <input type="checkbox"/> OVC IV
IP protection class	IPX0
Possible test case verdicts:	
- test case does not apply to the test object.....	N/A
- test object does meet the requirement	P (Pass)
- test object does not meet the requirement	F (Fail)
Testing	
Date of receipt of test item.....	2018-01-19
Date (s) of performance of tests.....	2018-02-05
General remarks:	
<p>The test results presented in this report relate only to the object tested. This report shall not be reproduced, except in full, without the written approval of the Issuing testing laboratory. "(see Enclosure #)" refers to additional information appended to the report. "(see appended table)" refers to a table appended to the report.</p> <p>Throughout this report a comma (point) is used as the decimal separator.</p> <p>This Test Report Form is intended for the investigation of safety of equipment to be installed outdoors in accordance with IEC 60950-22. It can only be used together with the IEC 60950-1 requirements.</p>	
Name and address of factory (ies):	
VIVOTEK INC 5TH FL, 168 LIEN CHENG RD CHUNG HO DISTRICT NEW TAIPEI, 235 TAIWAN	
General product information:	
Report Summary:	
All applicable tests according to the referenced standard(s) have been carried out.	
Product Description:	
The equipment is a Class III Network Camera, consists of electronic components mounted on PWB and housed with metal/plastic enclosure.	

Miscellaneous ID 4-01

Page 5 of 24

Report No. E324690- 4788944424 Original

The equipment will be installed to the ceiling or wall.

Model Difference:

Refer to IEC 60950-1 Main report

The official TRF used for this evaluation has not been updated to include CTF information. As a temporary solution the NCB included missing CTF page and informed IECEE Secretariat about the required TRF update.

Miscellaneous ID 4-01

Page 6 of 24 Report No. E324690- 4788944424 Original

IEC 60950-22			
Clause	Requirement + Test	Result - Remark	Verdict
4	CONDITIONS FOR OUTDOOR EQUIPMENT		P
4.1	Ambient air temperature		P
	Suitability for use at any temperature in the range specified by the manufacturer. If not specified by the manufacturer, the range is taken as -33°C to +40°C	-50 to 55 degree C for Model FD9387-EHTV and FD9387-EHV; -30 to 55 degree C for Model FD9387-HTV, FD9387-HV, and FD9387-HVTPM	P
4.2	AC mains supply		N/A
	Suitability for the highest Overvoltage Category expected in the installation location	Class III equipment.	N/A
	Components used to reduce the Overvoltage Category comply with IEC 61643-series		N/A
	Reference to installation instructions		N/A
4.3	Rise of earth potential		
	Special earthing conditions	Class III equipment.	N/A
	Reference to installation instructions		N/A
5	MARKING AND INSTRUCTIONS		P
	Special installation features for protection from conditions in the OUTDOOR LOCATION (see 1.7.2 of IEC 60950-1)	Precautions in the installation instruction.	P
	OUTDOOR ENCLOSURE classification according to IEC 60529 (IP Code)	The unit is considered as outdoor equipment	N/A
6	PROTECTION FROM ELECTRICAL SHOCK IN AN OUTDOOR LOCATION		P
6.1	Voltage limits of user-accessible parts in OUTDOOR LOCATIONS (2.2.2 and 2.2.3 of IEC 60950-1 with voltage limits of IEC 60950-22)		P
	Voltages under normal conditions (V)	Accessible parts are less than 21.2 Vp or 30Vdc and are classified as SELV.	P
	Voltages under fault conditions (V)	Single fault did not cause excessive voltage in accessible SELV circuits. Limits of 15 V a.c., 21,2 V peak, or 30 V d.c. for longer than 0,2 s under single fault conditions.	P
6.2	Limited current circuits in outdoor locations		N/A

Miscellaneous ID 4-01

Page 7 of 24 Report No. E324690- 4788944424 Original

IEC 60950-22			
Clause	Requirement + Test	Result - Remark	Verdict
	The requirements of 2.4 of IEC 60950-1 apply without change		N/A

Miscellaneous ID 4-01

Page 8 of 24 Report No. E324690- 4788944424 Original

IEC 60950-22			
Clause	Requirement + Test	Result - Remark	Verdict

7	WIRING TERMINALS FOR CONNECTION OF EXTERNAL CONDUCTORS		N/A
	The mains supply terminations powered via the normal building installation wiring are as specified in 3.3 of IEC 60950-1	Not directly connected to mains.	N/A
	The mains supply terminations powered directly from the mains distribution system are as specified in IEC 60364	Not directly connected to mains.	N/A

8	CONSTRUCTION REQUIREMENTS FOR OUTDOOR ENCLOSURES		P
8.1	General		P
	Protection against corrosion by use of suitable materials or by application of a protective coating	Metallic enclosure was made of aluminium.	P
	Parts serving as a functional part of an OUTDOOR ENCLOSURE (e.g., dials, connectors, etc.) comply with the same environmental protection requirements as for the OUTDOOR ENCLOSURE	All relevant parts comply with applicable requirements	P
	Use of OUTDOOR ENCLOSURE to carry current during normal operation	Outdoor enclosure does not carry current during normal operation.	P
	Connection of a conductive part of an OUTDOOR ENCLOSURE to protective earth for carrying fault currents (see 2.6 of IEC 60950-1 and 8.3 of this standard)		N/A
8.2	Resistance to ultra-violet radiation		N/A
	Resistance of non-metallic parts of an outdoor enclosure to degradation by ultra-violet (UV) radiation		N/A
	Parts providing mechanical support:		N/A
	Tensile strength test (ISO 527)		N/A
	Flexural strength test (ISO 178)		N/A
	Parts providing impact resistance:		N/A
	Charpy impact test (ISO 179)		N/A
	Izod impact test (ISO 180)		N/A
	Tensile impact test (ISO 8256)		N/A
	All parts:		N/A
	Flammability classification (1.2.12 and annex A of IEC 60950-1)		N/A

TRF No. IEC60950_22A

Miscellaneous ID 4-01

Page 9 of 24 Report No. E324690- 4788944424 Original

IEC 60950-22			
Clause	Requirement + Test	Result - Remark	Verdict
8.3	Resistance to corrosion		P
8.3.1	General	Metallic enclosure was made of aluminum and after evaluated/reviewed the data provided from manufacturer, the construction complied with requirements.	P
	Resistance of metallic parts of an OUTDOOR ENCLOSURE to the effects of water-borne contaminants		N/A
	Alternate method for 8.3.2-8.3.4 (IEC 61587-1)		N/A
8.3.2	Test apparatus		N/A
	Salt-spray test (IEC 60068-2-11)		N/A
	Test in a water-saturated sulphur dioxide atmosphere (water-saturated sulphur dioxide atmosphere as described in Annex A; chamber as described in ISO 3231)		N/A
8.3.3	Test procedure		N/A
8.3.4	Compliance criteria		N/A
8.4	Bottoms of FIRE ENCLOSURES		N/A
	Comply with 4.6.2 of IEC 60950-1	No bottom opening.	N/A
	Bottom of FIRE ENCLOSURE of OUTDOOR EQUIPMENT mounted directly and permanently on a non-combustible surface (e.g., concrete or metal)		N/A
8.5	Gaskets		P
	If gaskets are used as the method for protection against the ingress of potential contaminants, requirements of 8.5.1 through 8.5.3 apply	Annex D.2 Mfr. Momentive Performance Materials Japan L L C, model TSE2186U(aq) Mfr. AVC Industrial Corp., model S61 (AVC)	P
8.5.1	General		N/A
8.5.2	Oil resistance		N/A
8.5.3	Securing means	mechanical means used	P
9	PROTECTION OF EQUIPMENT WITHIN AN OUTDOOR ENCLOSURE		P
9.1	Protection from moisture (see Table 2)	After test, no water has entered to enclosure.	P

Miscellaneous ID 4-01

Page 10 of 24 Report No. E324690- 4788944424 Original

IEC 60950-22			
Clause	Requirement + Test	Result - Remark	Verdict
9.2	Protection from plants and vermin	No openings on the enclosure.	N/A
9.3	Protection from excessive dust		N/A

Miscellaneous ID 4-01

Page 11 of 24 Report No. E324690- 4788944424 Original

IEC 60950-22			
Clause	Requirement + Test	Result - Remark	Verdict
10	MECHANICAL STRENGTH OF ENCLOSURES		P
10.1	General		P
10.2	Impact test (4.2.5 of IEC 60950-1)	(see separate test report IEC 60950-1)	P
	Compliance criteria:		P
	- after test the level of protection remains in accordance with 9.1 of this standard		P
	- after test the requirements of 4.2.1 of IEC 60950-1 are met		P
11	OUTDOOR EQUIPMENT CONTAINING VENTED BATTERIES		N/A
	Adequate ventilation in the compartment housing a vented battery, where gassing is possible during normal usage or over-charging	No such battery was provided.	N/A
	Protection against the risk of ignition of local concentrations of hydrogen and oxygen in a compartment containing both a battery and electrical components		N/A
	Hydrogen gas concentration measurement test		N/A
	Measured hydrogen gas concentration (% by volume)		—
	Max. allowed gas concentration for the mixture location in proximity to an ignition source (% by volume)		—
	Max. allowed gas concentration for the mixture location not in proximity to an ignition source (% by volume)		—
	Overcharging of rechargeable battery (see 4.3.8 of IEC 60950-1)		N/A
A	ANNEX A, WATER-SATURATED SULPHUR DIOXIDE ATMOSPHERE (see 8.3.2 and 8.3.3)		N/A
B	ANNEX B, WATER SPRAY TEST (see 9.1)		P
C	ANNEX C, ULTRAVIOLET LIGHT CONDITIONING TEST (see 8.2)		N/A
C.1	Test apparatus.....		N/A
C.2	Mounting of test samples.....		N/A
C.3	Carbon-arc light-exposure apparatus		N/A

TRF No. IEC60950_22A

Miscellaneous ID 4-01

Page 12 of 24 Report No. E324690- 4788944424 Original

IEC 60950-22			
Clause	Requirement + Test	Result - Remark	Verdict
C.4	Xenon-arc light-exposure apparatus..... :		N/A
D	ANNEX D, GASKET TESTS (see 8.5)		P
D.1	Gasket tests		P
D.2	Tensile strength and elongation tests (for gaskets that can stretch)	Annex D.2 Mfr. Momentive Performance Materials Japan L L C, model TSE2186U(aq) Mfr. AVC Industrial Corp., model S61 (AVC)	P
	Tensile strength (%)		N/A
	Elongation (%)		N/A
	Visible deterioration, deformation, melting, cracking or hardening of the material	There was no visible cracking or other adverse effect of the conditioned material.	P
D.3	Compression test (for gaskets with closed cell construction)		N/A
	Initial thickness of the specimen (mm)		N/A
	Thickness of the specimen after test a) (mm), compression set after test a) (%).....		N/A
	Thickness of the specimen after test b) (mm), compression set after test b) (%).....		N/A
	Thickness of the specimen after test c) (mm), compression set after test c) (%).....		N/A
	Visible cracks or deterioration		N/A
D.4	Oil immersion test		N/A
	Swelling (%).....		N/A
	Shrinking (%).....		N/A
E	ANNEX E, RATIONALE		—
E.1	General		—
E.2	Electric shock		—
E.3	Energy related hazards		—
E.4	Fire		—
E.5	Mechanical hazards		—
E.6	Heat related hazards		—

Miscellaneous ID 4-01

Page 13 of 24 Report No. E324690- 4788944424 Original

IEC 60950-22			
Clause	Requirement + Test	Result - Remark	Verdict
E.7	Radiation		—
E.8	Chemical hazards		—
E.9	Biological hazards		—
E.10	Explosion hazards		—

Miscellaneous ID 4-01

Page 14 of 24 Report No. E324690- 4788944424 Original

IEC 60950-22			
Clause	Requirement + Test	Result - Remark	Verdict

IEC 60950-22:2005 – COMMON MODIFICATIONS			
Contents	Add the following annexes: Annex ZA (normative) Normative references to international publications with their corresponding European publications Annex ZB (normative) Special national conditions		N/A
General	Delete all the "country" notes in the reference document according to the following list: 4.1 Note 3 4.3 Note 8.5 Note 10.2 Note D.3 Note D.4 Note		N/A

ZA	NORMATIVE REFERENCES TO INTERNATIONAL PUBLICATIONS WITH THEIR CORRESPONDING EUROPEAN PUBLICATIONS		—
----	---	--	---

ZB	SPECIAL NATIONAL CONDITIONS		N/A
4.1	In Finland, Norway and Sweden , the temperature in winter may be extremely low. For OUTDOOR EQUIPMENT this will demand special design so that the equipment can withstand transport, erection and operation/service at temperatures down to -50°C	This National Condition has been removed in EN 60950-22:2006 + A11:2008.	N/A
10.2	In Finland, Norway and Sweden there are additional requirements for the minimum ambient temperature. See 4.1 of this annex.	This National Condition has been removed in EN 60950-22:2006 + A11:2008.	N/A
D.3	In Finland, Norway and Sweden there are additional requirements for the minimum ambient temperature. See 4.1 of this annex.	This National Condition has been removed in EN 60950-22:2006 + A11:2008.	N/A

Miscellaneous ID 4-01

Page 15 of 24 Report No. E324690- 4788944424 Original

IEC 60950-22

Clause	Requirement + Test	Result - Remark	Verdict
--------	--------------------	-----------------	---------

8.2 TABLE: Resistance to ultra-violet radiation			
8.2a)	Tensile strength test (ISO 527)		N/A
Material identification (manufacturer, type designation)			—
Shape and dimensions of test samples			—
Conditioning for Set 1 of samples			—
Conditioning for Set 2 of samples (including Annex C)			—
Test conditions (T °C, RH %)			—
Set 1 (without Annex C conditioning)		Set 2 (after Annex C conditioning)	
Test sample #	Tensile strength (MPa)	Test sample #	Tensile strength (MPa)
Arithmetic mean for Set 1 (MPa)			
Arithmetic mean for Set 2 (MPa)			
Retention (%)			
Supplementary information:			

Miscellaneous ID 4-01

Page 24 of 24 Report No. E324690- 4788944424 Original

IEC 60950-22			
Clause	Requirement + Test	Result - Remark	Verdict

ATTACHMENT

US - UL60950-22, First Edition - SPECIAL NATIONAL CONDITIONS			
4	Applicable parts of Chapter 8 of the NEC may be applicable to ITE installed outdoors with connections to communication systems		P
4.2	Power supply cords are to be suitable outdoor use type as required by Section 400-4 of the NEC, i.e., marked "water resistant," "outdoor," "W" or "W-A."		N/A
4.2	Surge Arrestors and Transient Voltage Surge Suppressors installed external to the ITE are required to comply with the appropriate NEC requirements.		N/A
5	Outdoor Enclosures are required to be classified and marked in accordance with UL 50		N/A
7	Applicable parts of the NEC, NFPA 70; and the National Electrical Safety Code, ANSI/IEEE C2, are required, as appropriate.		N/A
7	Wiring terminals intended to supply Class 2 outputs are required per Article 725 of the NEC to be marked.		N/A
11	Requires stationary installations of storage batteries external to the ITE to comply with Article 480 of the NEC		N/A
OTHER DIFFERENCES			
1.2	For protection of ITE against direct lightning strikes, reference is made to NFPA 780 for additional requirements.		P
2	All references to IEC 60950-1 in this standard are replaced by the equivalent UL 60950-1 Standards. All relevant Standards referenced in the Part 1 Standard (Annex P, including P.1 and P.2) also apply to this Part 22 Standard and are not listed below. All references to clauses and subclauses in IEC 60950-1 are to the second edition.		P

Miscellaneous ID 4-02

IECEE OD-2020-F1:2017 © IEC 2017
TRF Template



Ed.1.0
2017-05-17

Test Report issued under the responsibility of:



TEST REPORT IEC 62471 Photobiological safety of lamps and lamp systems	
Report Reference No.	4788944424-1
Date of issue	2019-05-24
Total number of pages	17
Name of Testing Laboratory preparing the Report	Underwriters Laboratories Taiwan Co., Ltd / 260 Da-Yeh Road TW-112 Peitou Taipei City, Chinese Taipei
Applicant's name	VIVOTEK INC
Address	6F, No.192, Lien-Cheng Rd., Chung-Ho, New Taipei City, 235, Taiwan
Test specification:	
Standard	IEC 62471:2006
Test procedure	Informative Report
Non-standard test method	N/A
Test Report Form No.	IEC62471B
TRF Originator	VDE Testing and Certification Institute
Master TRF	Dated 2018-08-16
Copyright © 2018 IEC System for Conformity Testing and Certification of Electrical Equipment (IECEE), Geneva, Switzerland. All rights reserved.	
This publication may be reproduced in whole or in part for non-commercial purposes as long as the IECEE is acknowledged as copyright owner and source of the material. IECEE takes no responsibility for and will not assume liability for damages resulting from the reader's interpretation of the reproduced material due to its placement and context.	
This report is not valid as a CB Test Report unless signed by an approved CB Testing Laboratory and appended to a CB Test Certificate issued by an NCB in accordance with IECEE 02.	
General disclaimer:	
The test results presented in this report relate only to the object tested. This report shall not be reproduced, except in full, without the written approval of the Issuing CB Testing Laboratory. The authenticity of this Test Report and its contents can be verified by contacting the NCB, responsible for this Test Report.	

Miscellaneous ID 4-02

Test item description	Network Camera	
Trade Mark		
Manufacturer	VIVOTEK INC 6F, No.192, Lien-Cheng Rd., Chung-Ho, New Taipei City, 235, Taiwan, R.O.C.	
Model/Type reference	FD9387-EHTV, FD9387-EHV, FD9387-HTV, FD9387-HV, FD9387-HVTPM, FD9187-HT, FD9187-H	
Ratings	(Optionally provided on marking plate) See page 6 for details (Exempt Group)	
Responsible Testing Laboratory (as applicable), testing procedure and testing location(s):		
<input type="checkbox"/>	CB Testing Laboratory:	
Testing location/ address	Underwriters Laboratories Taiwan Co., Ltd / 260 Da-Yeh Road TW-112 Peitou Taipei City, Chinese Taipei	
Tested by (name, function, signature)	Stanley Tsai / Project handler	
Approved by (name, function, signature) ..	Jerry Lin / Reviewer	
<input type="checkbox"/>	Testing procedure: CTF Stage 1:	
Testing location/ address		
Tested by (name, function, signature)		
Approved by (name, function, signature) ..		
<input type="checkbox"/>	Testing procedure: CTF Stage 2:	
Testing location/ address		
Tested by (name + signature)		
Witnessed by (name, function, signature) .:		
Approved by (name, function, signature) ..:		
<input type="checkbox"/>	Testing procedure: CTF Stage 3:	
<input type="checkbox"/>	Testing procedure: CTF Stage 4:	
Testing location/ address		
Tested by (name, function, signature)		
Witnessed by (name, function, signature) .:		
Approved by (name, function, signature) ..:		
Supervised by (name, function, signature) :		

Miscellaneous ID 4-02

Page 3 of 17

Report No.: 4788901295-1

<p>List of Attachments (including a total number of pages in each attachment): Enclosure - Photos (total 5 pages) Table – Additional test table (total 3 pages)</p>	
<p>Summary of testing:</p>	
<p>Tests performed (name of test and test clause):</p> <p>The product was tested and classified according to the following clauses: Irradiance Measurement – 5.2.1 Radiance Measurement – 5.2.2</p>	<p>Testing location:</p> <p>Underwriters Laboratories Taiwan Co., Ltd Lab 3: No.2, Wenming 1st St. Guishan, Taoyuan City TW-333 Taiwan Chinese Taipei</p>
<p>Summary of compliance with National Differences (List of countries addressed):</p> <p><input type="checkbox"/> The product fulfils the requirements of _____ (insert standard number and edition and delete the text in parenthesis, leave it blank or delete the whole sentence, if not applicable)</p>	

Miscellaneous ID 4-02

Copy of marking plate:

The artwork below may be only a draft. The use of certification marks on a product must be authorized by the respective NCBs that own these marks.

<p>FD9187-H Network Camera</p> <p>MAC:0002D1XXXXXX</p>  <p>12V=0.87A PoE 37-57V=0.31-0.20A</p>  <p>This device complies with Part 15 of the FCC Rules. Operation is subject to the following two conditions: (1) this device may not cause harmful interference, and (2) this device must accept any interference received, including interference that may cause undesired operation. Brand Owner Add.: 6F, No.192, Lian-Cheng Rd., Chung-Ho, New Taipei City, 235, Taiwan, R.O.C. M.F.S. Add.: 5F, 1F, 1F-2, No.168, Lian-Cheng Rd., Zhonghe Dist., New Taipei City 235, Taiwan, R.O.C. Pat.6, 930, 709 www.vivotek.com Made in Taiwan</p>	<p>FD9187-HT Network Camera</p> <p>MAC:0002D1XXXXXX</p>  <p>12V=0.87A PoE 37-57V=0.31-0.20A</p>  <p>This device complies with Part 15 of the FCC Rules. Operation is subject to the following two conditions: (1) this device may not cause harmful interference, and (2) this device must accept any interference received, including interference that may cause undesired operation. Brand Owner Add.: 6F, No.192, Lian-Cheng Rd., Chung-Ho, New Taipei City, 235, Taiwan, R.O.C. M.F.S. Add.: 5F, 1F, 1F-2, No.168, Lian-Cheng Rd., Zhonghe Dist., New Taipei City 235, Taiwan, R.O.C. Pat.6, 930, 709 www.vivotek.com Made in Taiwan</p>
<p>FD9387-HTV Network Camera</p> <p>MAC:0002D1XXXXXX</p>  <p>12V=0.87A PoE 37-57V=0.31-0.20A</p>  <p>This device complies with Part 15 of the FCC Rules. Operation is subject to the following two conditions: (1) this device may not cause harmful interference, and (2) this device must accept any interference received, including interference that may cause undesired operation. Brand Owner Add.: 6F, No.192, Lian-Cheng Rd., Chung-Ho, New Taipei City, 235, Taiwan, R.O.C. M.F.S. Add.: 5F, 1F, 1F-2, No.168, Lian-Cheng Rd., Zhonghe Dist., New Taipei City 235, Taiwan, R.O.C. Pat.6, 930, 709 www.vivotek.com Made in Taiwan</p>	<p>FD9387-EHTV Network Camera</p> <p>MAC:0002D1XXXXXX</p>  <p>12V=1.9A PoE 42.5-57V=0.59-0.44A</p>  <p>This device complies with Part 15 of the FCC Rules. Operation is subject to the following two conditions: (1) this device may not cause harmful interference, and (2) this device must accept any interference received, including interference that may cause undesired operation. Brand Owner Add.: 6F, No.192, Lian-Cheng Rd., Chung-Ho, New Taipei City, 235, Taiwan, R.O.C. M.F.S. Add.: 5F, 1F, 1F-2, No.168, Lian-Cheng Rd., Zhonghe Dist., New Taipei City 235, Taiwan, R.O.C. Pat.6, 930, 709 www.vivotek.com Made in Taiwan</p>
<p>FD9387-HVTPM Network Camera</p> <p>MAC:0002D1XXXXXX</p>  <p>12V=0.87A PoE 37-57V=0.31-0.20A</p>  <p>This device complies with Part 15 of the FCC Rules. Operation is subject to the following two conditions: (1) this device may not cause harmful interference, and (2) this device must accept any interference received, including interference that may cause undesired operation. Brand Owner Add.: 6F, No.192, Lian-Cheng Rd., Chung-Ho, New Taipei City, 235, Taiwan, R.O.C. M.F.S. Add.: 5F, 1F, 1F-2, No.168, Lian-Cheng Rd., Zhonghe Dist., New Taipei City 235, Taiwan, R.O.C. Pat.6, 930, 709 www.vivotek.com Made in Taiwan</p>	<p>FD9387-HV Network Camera</p> <p>MAC:0002D1XXXXXX</p>  <p>12V=0.87A PoE 37-57V=0.31-0.20A</p>  <p>This device complies with Part 15 of the FCC Rules. Operation is subject to the following two conditions: (1) this device may not cause harmful interference, and (2) this device must accept any interference received, including interference that may cause undesired operation. Brand Owner Add.: 6F, No.192, Lian-Cheng Rd., Chung-Ho, New Taipei City, 235, Taiwan, R.O.C. M.F.S. Add.: 5F, 1F, 1F-2, No.168, Lian-Cheng Rd., Zhonghe Dist., New Taipei City 235, Taiwan, R.O.C. Pat.6, 930, 709 www.vivotek.com Made in Taiwan</p>
<p>FD9387-EHV Network Camera</p> <p>MAC:0002D1XXXXXX</p>  <p>12V=1.9A PoE 42.5-57V=0.59-0.44A</p>  <p>This device complies with Part 15 of the FCC Rules. Operation is subject to the following two conditions: (1) this device may not cause harmful interference, and (2) this device must accept any interference received, including interference that may cause undesired operation. Brand Owner Add.: 6F, No.192, Lian-Cheng Rd., Chung-Ho, New Taipei City, 235, Taiwan, R.O.C. M.F.S. Add.: 5F, 1F, 1F-2, No.168, Lian-Cheng Rd., Zhonghe Dist., New Taipei City 235, Taiwan, R.O.C. Pat.6, 930, 709 www.vivotek.com Made in Taiwan</p>	

Miscellaneous ID 4-02

Page 5 of 17

Report No.: 4788944424-1

Test item particulars	See below
Tested lamp	<input checked="" type="checkbox"/> continuous wave lamps <input type="checkbox"/> pulsed lamps
Tested lamp system	See general product information
Lamp classification group	<input checked="" type="checkbox"/> exempt <input type="checkbox"/> risk 1 <input type="checkbox"/> risk 2 <input type="checkbox"/> risk 3
Lamp cap	N/A
Bulb	N/A
Rated of the lamp	N/A
Furthermore marking on the lamp	N/A
Seasoning of lamps according IEC standard	Not covered in this report
Used measurement instrument	N/A
Temperature by measurement	25°C, 24.7 °C
Information for safety use	Not covered in this report
Possible test case verdicts:	
– test case does not apply to the test object : N/A	
– test object does meet the requirement : P (Pass)	
– test object does not meet the requirement : F (Fail)	
Testing:	
Date of receipt of test item	2019-04-17, 2019-05-08
Date (s) of performance of tests	2019-04-18, 2019-05-15
General remarks:	
"(See Enclosure #)" refers to additional information appended to the report. "(See appended table)" refers to a table appended to the report.	
Throughout this report a <input type="checkbox"/> comma / <input checked="" type="checkbox"/> point is used as the decimal separator.	
Manufacturer's Declaration per sub-clause 4.2.5 of IEC60060-2:	
The application for obtaining a CB Test Certificate includes more than one factory location and a declaration from the Manufacturer stating that the sample(s) submitted for evaluation is (are) representative of the products from each factory has been provided	<input type="checkbox"/> Yes <input checked="" type="checkbox"/> Not applicable
When differences exist; they shall be identified in the General product information section.	
Name and address of factory (ies)	VIVOTEK INC 5TH FL., 168 LIEN CHENG RD CHUNG HO DISTRICT NEW TAIPEI, 235 TAIWAN

Miscellaneous ID 4-02

General product information and other remarks:

- The equipment is a Network Camera, intended for used with information technology equipment.
- The test sample was a pre-production sample without serial number.
- Only photobiological hazards have been addressed.

Optical LED information:

LED board (Fix), Infrared LED made by:

LD3: Lextar, TYPE: PR35F0A (370015500G), 850nm, 209 mW/sr.

LD5: Lextar, TYPE: PR35F0A (370015500G), 850nm, 209 mW/sr.

(CW mode, total two Infrared LEDs on module)

LED board (Remote), Infrared LED made by:

LD1: Lextar, TYPE: PR88F03 (370014700G), 850nm, 210 mW/sr.

LD2: Lextar, TYPE: PR88F03 (370014700G), 850nm, 210 mW/sr.

LD3: Lextar, TYPE: PR35F0A (370015500G), 850nm, 209 mW/sr.

LD4: Lextar, TYPE: PR35F0A (370015500G), 850nm, 209 mW/sr.

(CW mode, total four Infrared LEDs on module)

Only photobiological hazards have been addressed.

Model difference:

	FD9387-EH TV	FD9387-E HV	FD9387-HTV	FD9387 -HV	FD9387-H VTPM	FD9187-HT	FD9187-H
Rating	PoE 42.5-57V, 0.59-0.44A DC 12V, 1.9A		PoE 37-57V, 0.31-0.20A DC 12V, 0.87A			PoE 37-57V, 0.31-0.20A DC 12V, 0.87A	
Tma	-50°C ~55°C		-30°C ~55°C			-10°C ~50°C	
Heater	YES		No			No	
Enclosure	Metal (Outdoor)		Metal (Outdoor)			Plastic (Indoor)	
Lens	Remote (HD27135)	Fix (YT1011)	Remote (HD27135)	Fix (YT1011)	Remote (HD27135)	Fix (YT1011)	
LED board	Remote	Fix	Remote	Fix	Remote	Fix	

Miscellaneous ID 4-02

Page 7 of 17

Report No.: 4788944424-1

IEC 62471			
Clause	Requirement + Test	Result – Remark	Verdict
4	EXPOSURE LIMITS		P
4.1	General		P
	The exposure limits in this standard is not less than 0,01 ms and not more than any 8-hour period and should be used as guides in the control of exposure		P
	Detailed spectral data of a light source are generally required only if the luminance of the source exceeds 10^4 cd m^{-2}	see clause 4.3	P
4.3	Hazard exposure limits		P
4.3.1	Actinic UV hazard exposure limit for the skin and eye		N/A
	The exposure limit for effective radiant exposure is 30 J m^{-2} within any 8-hour period		N/A
	To protect against injury of the eye or skin from ultraviolet radiation exposure produced by a broadband source, the effective integrated spectral irradiance, E_s , of the light source shall not exceed the levels defined by:		N/A
	$E_s \cdot t = \sum_{200}^{400} \sum_t E_\lambda(\lambda, t) \cdot S_{UV}(\lambda) \cdot \Delta t \cdot \Delta \lambda \leq 30 \quad \text{J m}^{-2}$		N/A
	The permissible time for exposure to ultraviolet radiation incident upon the unprotected eye or skin shall be computed by:		N/A
	$t_{\max} = \frac{30}{E_s} \quad \text{s}$		N/A
4.3.2	Near-UV hazard exposure limit for eye		N/A
	For the spectral region 315 nm to 400 nm (UV-A) the total radiant exposure to the eye shall not exceed 10000 J m^{-2} for exposure times less than 1000 s. For exposure times greater than 1000 s (approximately 16 minutes) the UV-A irradiance for the unprotected eye, E_{UVA} , shall not exceed 10 W m^{-2} .		N/A
	The permissible time for exposure to ultraviolet radiation incident upon the unprotected eye for time less than 1000 s, shall be computed by:		N/A
	$t_{\max} \leq \frac{10\,000}{E_{UVA}} \quad \text{s}$		N/A
4.3.3	Retinal blue light hazard exposure limit		P
	To protect against retinal photochemical injury from chronic blue-light exposure, the integrated spectral radiance of the light source weighted against the blue-light hazard function, $B(\lambda)$, i.e., the blue-light weighted radiance, L_B , shall not exceed the levels defined by:		P
	$L_B \cdot t = \sum_{300}^{700} L_\lambda(\lambda, t) \cdot B(\lambda) \cdot \Delta t \cdot \Delta \lambda \leq 10^6 \quad \text{J} \cdot \text{m}^{-2} \cdot \text{sr}^{-1}$	for $t \leq 10^4 \text{ s}$ $t_{\max} = \frac{10^6}{L_B}$	P

Miscellaneous ID 4-02

Page 8 of 17

Report No.: 4788944424-1

IEC 62471			
Clause	Requirement + Test	Result – Remark	Verdict
	$L_B = \sum_{300}^{700} L_\lambda \cdot B(\lambda) \cdot \Delta\lambda \leq 100 \quad \text{W} \cdot \text{m}^{-2} \cdot \text{sr}^{-1}$	for $t > 10^4$ s	P
4.3.4	Retinal blue light hazard exposure limit - small source		N/A
	Thus the spectral irradiance at the eye E_λ , weighted against the blue-light hazard function $B(\lambda)$ shall not exceed the levels defined by:	The sources of LED are small source. See table 6.1 for details.	N/A
	$E_B \cdot t = \sum_{300}^{700} \sum_t E_\lambda(\lambda, t) \cdot B(\lambda) \cdot \Delta\lambda \leq 100 \quad \text{J} \cdot \text{m}^{-2}$	for $t \leq 100$ s	N/A
	$E_B = \sum_{300}^{700} E_\lambda \cdot B(\lambda) \cdot \Delta\lambda \leq 1 \quad \text{W} \cdot \text{m}^{-2}$	for $t > 100$ s	N/A
4.3.5	Retinal thermal hazard exposure limit		P
	To protect against retinal thermal injury, the integrated spectral radiance of the light source, L_λ , weighted by the burn hazard weighting function $R(\lambda)$ (from Figure 4.2 and Table 4.2), i.e., the burn hazard weighted radiance, shall not exceed the levels defined by:		P
	$L_R = \sum_{380}^{1400} L_\lambda \cdot R(\lambda) \cdot \Delta\lambda \leq \frac{50\,000}{\alpha \cdot t^{0.25}} \quad \text{W} \cdot \text{m}^{-2} \cdot \text{sr}^{-1}$	($10 \mu\text{s} \leq t \leq 10$ s)	P
4.3.6	Retinal thermal hazard exposure limit – weak visual stimulus		P
	For an infrared heat lamp or any near-infrared source where a weak visual stimulus is inadequate to activate the aversion response, the near infrared (780 nm to 1400 nm) radiance, L_{IR} , as viewed by the eye for exposure times greater than 10 s shall be limited to:		P
	$L_{IR} = \sum_{780}^{1400} L_\lambda \cdot R(\lambda) \cdot \Delta\lambda \leq \frac{6\,000}{\alpha} \quad \text{W} \cdot \text{m}^{-2} \cdot \text{sr}^{-1}$	$t > 10$ s	P
4.3.7	Infrared radiation hazard exposure limits for the eye		P
	The avoid thermal injury of the cornea and possible delayed effects upon the lens of the eye (cataractogenesis), ocular exposure to infrared radiation, E_{IR} , over the wavelength range 780 nm to 3000 nm, for times less than 1000 s, shall not exceed:		P
	$E_{IR} = \sum_{780}^{3000} E_\lambda \cdot \Delta\lambda \leq 18\,000 \cdot t^{-0.75} \quad \text{W} \cdot \text{m}^{-2}$	$t \leq 1000$ s	P
	For times greater than 1000 s the limit becomes:		P
	$E_{IR} = \sum_{780}^{3000} E_\lambda \cdot \Delta\lambda \leq 100 \quad \text{W} \cdot \text{m}^{-2}$	$t > 1000$ s	P
4.3.8	Thermal hazard exposure limit for the skin		N/A
	Visible and infrared radiant exposure (380 nm to 3000 nm) of the skin shall be limited to:		N/A

Miscellaneous ID 4-02

Page 9 of 17

Report No.: 4788944424-1

IEC 62471			
Clause	Requirement + Test	Result – Remark	Verdict
	$E_H \cdot t = \sum_{380}^{3000} \sum_{\tau} E_{\lambda}(\lambda, \tau) \cdot \Delta\lambda \cdot \Delta\tau \leq 20\,000 \cdot t^{0,25} \quad \text{J} \cdot \text{m}^{-2}$		N/A
5	MEASUREMENT OF LAMPS AND LAMP SYSTEMS		P
5.1	Measurement conditions		P
	Measurement conditions shall be reported as part of the evaluation against the exposure limits and the assignment of risk classification.		P
5.1.1	Lamp ageing (seasoning)		N/A
	Seasoning of lamps shall be done as stated in the appropriate IEC lamp standard.		N/A
5.1.2	Test environment		P
	For specific test conditions, see the appropriate IEC lamp standard or in absence of such standards, the appropriate national standards or manufacturer's recommendations.		P
5.1.3	Extraneous radiation		P
	Careful checks should be made to ensure that extraneous sources of radiation and reflections do not add significantly to the measurement results.		P
5.1.4	Lamp operation		N/A
	Operation of the test lamp shall be provided in accordance with:		N/A
	– the appropriate IEC lamp standard, or		N/A
	– the manufacturer's recommendation		N/A
5.1.5	Lamp system operation		P
	The power source for operation of the test lamp shall be provided in accordance with:		P
	– the appropriate IEC standard, or		N/A
	– the manufacturer's recommendation		P
5.2	Measurement procedure		P
5.2.1	Irradiance measurements		P
	Minimum aperture diameter 7mm.		P
	Maximum aperture diameter 50 mm.		P
	The measurement shall be made in that position of the beam giving the maximum reading.		P
	The measurement instrument is adequate calibrated.		P
5.2.2	Radiance measurements		P
5.2.2.1	Standard method		P
	The measurements made with an optical system.		P
	The instrument shall be calibrated to read in absolute radiant power per unit receiving area and per unit solid angle to acceptance averaged over the field of view of the instrument.		P

TRF No. IEC62471B

Miscellaneous ID 4-02

Page 10 of 17

Report No.: 4788944424-1

IEC 62471			
Clause	Requirement + Test	Result – Remark	Verdict
5.2.2.2	Alternative method		N/A
	Alternatively to an imaging radiance set-up, an irradiance measurement set-up with a circular field stop placed at the source can be used to perform radiance measurements.		N/A
5.2.3	Measurement of source size		P
	The determination of α , the angle subtended by a source, requires the determination of the 50% emission points of the source.		P
5.2.4	Pulse width measurement for pulsed sources		N/A
	The determination of Δt , the nominal pulse duration of a source, requires the determination of the time during which the emission is > 50% of its peak value.		N/A
5.3	Analysis methods		P
5.3.1	Weighting curve interpolations		P
	To standardize interpolated values, use linear interpolation on the log of given values to obtain intermediate points at the wavelength intervals desired.	see table 4.1	P
5.3.2	Calculations		P
	The calculation of source hazard values shall be performed by weighting the spectral scan by the appropriate function and calculating the total weighted energy.		P
5.3.3	Measurement uncertainty		P
	The quality of all measurement results must be quantified by an analysis of the uncertainty.	see Annex C in the norm	P
6	LAMP CLASSIFICATION		P
	For the purposes of this standard it was decided that the values shall be reported as follows:	see table 6.1	P
	– for lamps intended for general lighting service, the hazard values shall be reported as either irradiance or radiance values at a distance which produces an illuminance of 500 lux, but not at a distance less than 200 mm		N/A
	– for all other light sources, including pulsed lamp sources, the hazard values shall be reported at a distance of 200 mm		P
6.1	Continuous wave lamps		P
6.1.1	Except Group		P
	In the except group are lamps, which does not pose any photobiological hazard. The requirement is met by any lamp that does not pose:		P
	– an actinic ultraviolet hazard (E_s) within 8-hours exposure (30000 s), nor		P
	– a near-UV hazard (E_{UVa}) within 1000 s, (about 16 min), nor		P

TRF No. IEC62471B

Miscellaneous ID 4-02

Page 11 of 17

Report No.: 4788944424-1

IEC 62471			
Clause	Requirement + Test	Result – Remark	Verdict
	– a retinal blue-light hazard (L_B) within 10000 s (about 2,8 h), nor		P
	– a retinal thermal hazard (L_R) within 10 s, nor		P
	– an infrared radiation hazard for the eye (E_{IR}) within 1000 s		P
6.1.2	Risk Group 1 (Low-Risk)		N/A
	In this group are lamps, which exceeds the limits for the except group but that does not pose:		NA
	– an actinic ultraviolet hazard (E_s) within 10000 s, nor		NA
	– a near ultraviolet hazard (E_{UVA}) within 300 s, nor		NA
	– a retinal blue-light hazard (L_B) within 100 s, nor		NA
	– a retinal thermal hazard (L_R) within 10 s, nor		NA
	– an infrared radiation hazard for the eye (E_{IR}) within 100 s		NA
	Lamps that emit infrared radiation without a strong visual stimulus and do not pose a near-infrared retinal hazard (L_{IR}), within 100 s are in Risk Group 1.		NA
6.1.3	Risk Group 2 (Moderate-Risk)		NA
	This requirement is met by any lamp that exceeds the limits for Risk Group 1, but that does not pose:		NA
	– an actinic ultraviolet hazard (E_s) within 1000 s exposure, nor		NA
	– a near ultraviolet hazard (E_{UVA}) within 100 s, nor		NA
	– a retinal blue-light hazard (L_B) within 0,25 s (aversion response), nor		NA
	– a retinal thermal hazard (L_R) within 0,25 s (aversion response), nor		NA
	– an infrared radiation hazard for the eye (E_{IR}) within 10 s		NA
	Lamps that emit infrared radiation without a strong visual stimulus and do not pose a near-infrared retinal hazard (L_{IR}), within 10 s are in Risk Group 2.		NA
6.1.4	Risk Group 3 (High-Risk)		NA
	Lamps which exceed the limits for Risk Group 2 are in Group 3.		N/A
6.2	Pulsed lamps		N/A
	Pulse lamp criteria shall apply to a single pulse and to any group of pulses within 0,25 s.		NA
	A pulsed lamp shall be evaluated at the highest nominal energy loading as specified by the manufacturer.		NA
	The risk group determination of the lamp being tested shall be made as follows:		NA

TRF No. IEC62471B

Miscellaneous ID 4-02

Page 12 of 17

Report No.: 4788944424-1

IEC 62471			
Clause	Requirement + Test	Result – Remark	Verdict
	– a lamp that exceeds the exposure limit shall be classified as belonging to Risk Group 3 (High-Risk)		NA
	– for single pulsed lamps, a lamp whose weighted radiant exposure or weighted radiance does is below the EL shall be classified as belonging to the Exempt Group		NA
	– for repetitively pulsed lamps, a lamp whose weighted radiant exposure or weighted radiance dose is below the EL, shall be evaluated using the continuous wave risk criteria discussed in clause 6.1, using time averaged values of the pulsed emission		NA

Miscellaneous ID 4-02

Page 13 of 17

Report No.: 4788944424-1

IEC 62471			
Clause	Requirement + Test	Result – Remark	Verdict

Table 4.1 Spectral weighting function for assessing ultraviolet hazards for skin and eye			P
Wavelength λ , nm	UV hazard function $S_{uv}(\lambda)$	Wavelength λ , nm	UV hazard function $S_{uv}(\lambda)$
200	0,030	313*	0,006
205	0,051	315	0,003
210	0,075	316	0,0024
215	0,095	317	0,0020
220	0,120	318	0,0016
225	0,150	319	0,0012
230	0,190	320	0,0010
235	0,240	322	0,00067
240	0,300	323	0,00054
245	0,360	325	0,00050
250	0,430	328	0,00044
254*	0,500	330	0,00041
255	0,520	333*	0,00037
260	0,650	335	0,00034
265	0,810	340	0,00028
270	1,000	345	0,00024
275	0,960	350	0,00020
280*	0,880	355	0,00016
285	0,770	360	0,00013
290	0,640	365*	0,00011
295	0,540	370	0,000093
297*	0,460	375	0,000077
300	0,300	380	0,000064
303*	0,120	385	0,000053
305	0,060	390	0,000044
308	0,026	395	0,000036
310	0,015	400	0,000030

¹ Wavelengths chosen are representative: other values should be obtained by logarithmic interpolation at intermediate wavelengths.
* Emission lines of a mercury discharge spectrum.

Miscellaneous ID 4-02

Page 14 of 17

Report No.: 4788944424-1

IEC 62471			
Clause	Requirement + Test	Result – Remark	Verdict

Table 4.2		Spectral weighting functions for assessing retinal hazards from broadband optical sources	P
Wavelength nm	Blue-light hazard function B (λ)	Burn hazard function R (λ)	
300	0,01		
305	0,01		
310	0,01		
315	0,01		
320	0,01		
325	0,01		
330	0,01		
335	0,01		
340	0,01		
345	0,01		
350	0,01		
355	0,01		
360	0,01		
365	0,01		
370	0,01		
375	0,01		
380	0,01	0,1	
385	0,013	0,13	
390	0,025	0,25	
395	0,05	0,5	
400	0,10	1,0	
405	0,20	2,0	
410	0,40	4,0	
415	0,80	8,0	
420	0,90	9,0	
425	0,95	9,5	
430	0,98	9,8	
435	1,00	10,0	
440	1,00	10,0	
445	0,97	9,7	
450	0,94	9,4	
455	0,90	9,0	
460	0,80	8,0	
465	0,70	7,0	
470	0,62	6,2	
475	0,55	5,5	
480	0,45	4,5	
485	0,40	4,0	
490	0,22	2,2	
495	0,16	1,6	
500-600	$10^{[(450-\lambda)/50]}$	1,0	
600-700	0,001	1,0	
700-1050		$10^{[(700-\lambda)/500]}$	
1050-1150		0,2	
1150-1200		$0,2 \cdot 10^{0,02(1150-\lambda)}$	
1200-1400		0,02	

Miscellaneous ID 4-02

Page 15 of 17

Report No.: 4788944424-1

IEC 62471			
Clause	Requirement + Test	Result – Remark	Verdict

Table 5.4 Summary of the ELs for the surface of the skin or cornea (irradiance based values)						P
Hazard Name	Relevant equation	Wavelength range nm	Exposure duration sec	Limiting aperture rad (deg)	EL in terms of constant irradiance $W \cdot m^{-2}$	
Actinic UV skin & eye	$E_s = \sum E_\lambda \cdot S(\lambda) \cdot \Delta\lambda$	200 – 400	< 30000	1,4 (80)	30/t	
Eye UV-A	$E_{UVA} = \sum E_\lambda \cdot \Delta\lambda$	315 – 400	≤ 1000 > 1000	1,4 (80)	10000/t 10	
Blue-light small source	$E_B = \sum E_\lambda \cdot B(\lambda) \cdot \Delta\lambda$	300 – 700	≤ 100 > 100	< 0,011	100/t 1,0	
Eye IR	$E_{IR} = \sum E_\lambda \cdot \Delta\lambda$	780 – 3000	≤ 1000 > 1000	1,4 (80)	18000/t ^{0.75} 100	
Skin thermal	$E_H = \sum E_\lambda \cdot \Delta\lambda$	380 – 3000	< 10	2π sr	20000/t ^{0.75}	

Table 5.5 Summary of the ELs for the retina (radiance based values)						P
Hazard Name	Relevant equation	Wavelength range nm	Exposure duration sec	Field of view radians	EL in terms of constant radiance $W \cdot m^{-2} \cdot sr^{-1}$	
Blue light	$L_B = \sum L_\lambda \cdot B(\lambda) \cdot \Delta\lambda$	300 – 700	0,25 – 10 10-100 100-10000 ≥ 10000	$0,011 \cdot \sqrt{(t/10)}$ 0,011 $0,0011 \cdot \sqrt{t}$ 0,1	$10^6/t$ $10^6/t$ $10^6/t$ 100	
Retinal thermal	$L_R = \sum L_\lambda \cdot R(\lambda) \cdot \Delta\lambda$	380 – 1400	< 0,25 0,25 – 10	0,0017 $0,011 \cdot \sqrt{(t/10)}$	$50000/(\alpha \cdot t^{0.25})$ $50000/(\alpha \cdot t^{0.25})$	
Retinal thermal (weak visual stimulus)	$L_{IR} = \sum L_\lambda \cdot R(\lambda) \cdot \Delta\lambda$	780 – 1400	> 10	0,011	6000/α	

Miscellaneous ID 4-02

Page 16 of 17

Report No.: 4788901295-1

IEC 62471			
Clause	Requirement + Test	Result – Remark	Verdict

Risk	Action spectrum	Symbol	Units	Emission Measurement					
				Exempt		Low risk		Mod risk	
				Limit	Result	Limit	Result	Limit	Result
Actinic UV	$S_{UV}(\lambda)$	E_s	$W \cdot m^{-2}$	0,001	0.000E+00	0,003	0.000E+00	0,03	0.000E+00
Near UV		E_{UVA}	$W \cdot m^{-2}$	10	0.000E+00	33	0.000E+00	100	0.000E+00
Blue light	$B(\lambda)$	L_B	$W \cdot m^{-2} \cdot sr^{-1}$	100	6.530E-02	10000	2.542E+00	4000000	5.828E+00
Blue light, small source	$B(\lambda)$	E_B	$W \cdot m^{-2}$	1,0*	-	1,0	-	400	-
Retinal thermal	$R(\lambda)$	L_R	$W \cdot m^{-2} \cdot sr^{-1}$	6.112E+05	6.105E+03	6.112E+05	6.105E+03	1.550E+06	1.400E+04
Retinal thermal, weak visual stimulus**	$R(\lambda)$	L_{IR}	$W \cdot m^{-2} \cdot sr^{-1}$	1.310E+05	5.977E+03	1.310E+05	5.977E+03	1.310E+05	5.977E+03
IR radiation, eye		E_{IR}	$W \cdot m^{-2}$	100	4.663E+00	570	4.663E+00	3200	4.663E+00

* Small source defined as one with $\alpha < 0,011$ radian. Averaging field of view at 10000 s is 0,1 radian.
** Involves evaluation of non-GLS source
Angular subtense of apparent source: $\alpha=45.81$ mrad
Test condition: Normal condition (CW mode) for fix LED board
Conclusion: Infrared LED (LD3, LD5): Lextar / PR35F0A (370015500G) were assigned as Exempt Group.

TRF No. IEC62471B

Miscellaneous ID 4-02

List of test equipment used:

A completed list of used test equipment shall be provided in the Test Reports when a Customer's Testing Facility according to CTF stage 1 or CTF stage 2 procedure has been used.

Note: This page may be removed when CTF stage 1 or CTF stage 2 are not used. See also clause 4.8 in OD 2020 for more details.

Clause	Measurement / testing	Testing / measuring equipment / material used, (Equipment ID)	Range used	Last Calibration date	Calibration due date
N/A					

Miscellaneous ID 4-02

Enclose : Photo

Page 1 of 5

Report No.: 4788944424-1

Fig.1: Overall view (For Model FD9387-EHV w/ fix LED board)



Fig.2: Internal view (For Model FD9387-EHV w/ fix LED board)



Miscellaneous ID 4-02

Enclose : Photo

Page 2 of 5

Report No.: 4788944424-1

Fig.3: Fix LED board view-1

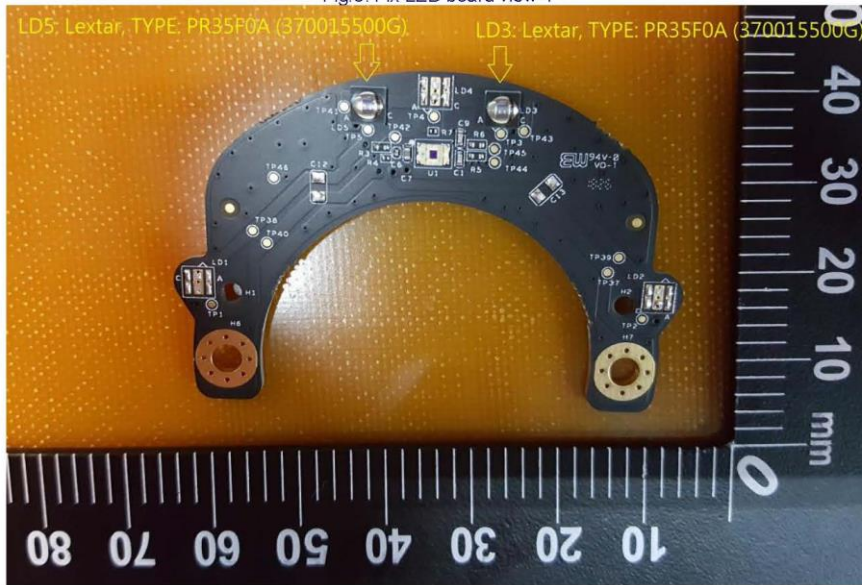
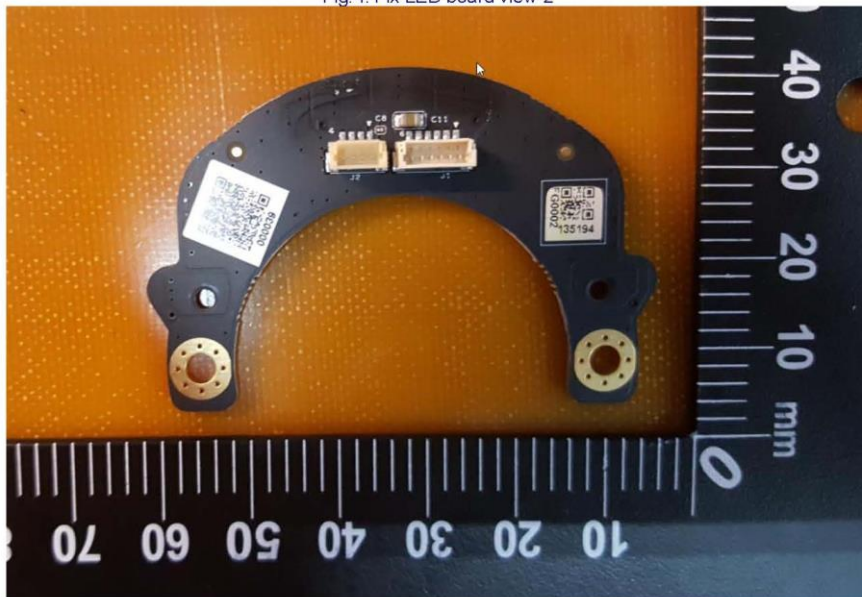

Fig.4: Fix LED board view-2



Miscellaneous ID 4-02

Enclose : Photo

Page 3 of 5

Report No.: 4788944424-1

Fig.5: Overall view-1 (For Model FD9387-HTV w/ remote LED board)



Fig.6: Overall view-2 (For Model FD9387-HTV w/ remote LED board)



Miscellaneous ID 4-02

Enclose : Photo

Page 4 of 5

Report No.: 4788944424-1

Fig.7: Internal view-1 (For Model FD9387-HTV w/ remote LED board)



Fig.8: Internal view-2 (For Model FD9387-HTV w/ remote LED board)

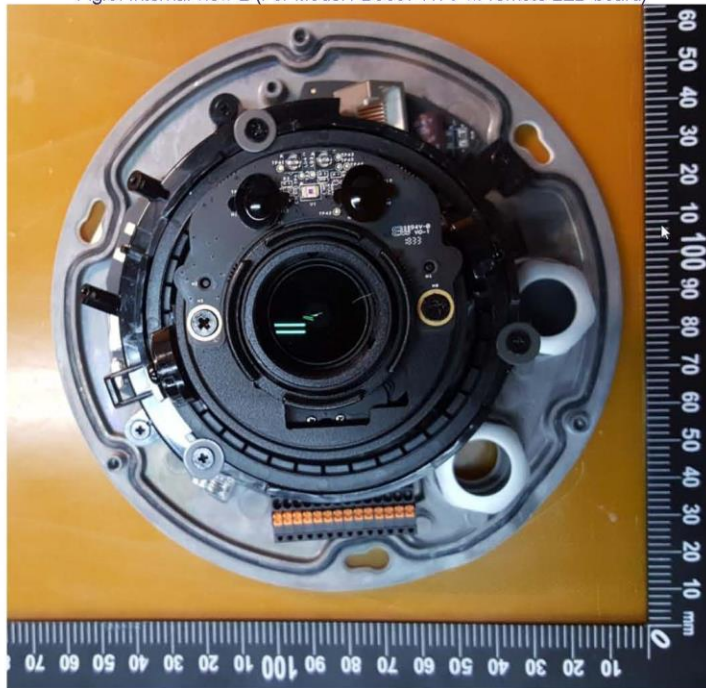

Miscellaneous ID 4-02

Enclose : Photo

Page 5 of 5

Report No.: 4788944424-1

Fig.9: Remote LED board view-1

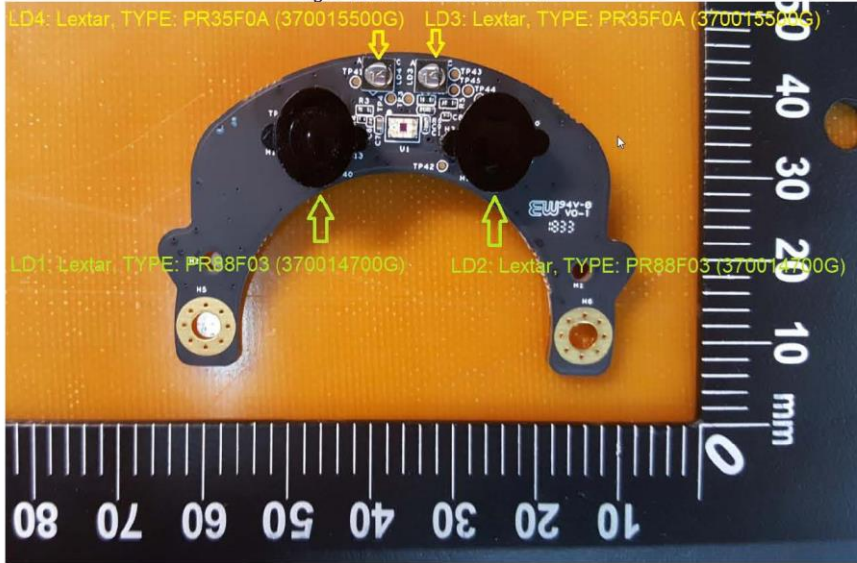
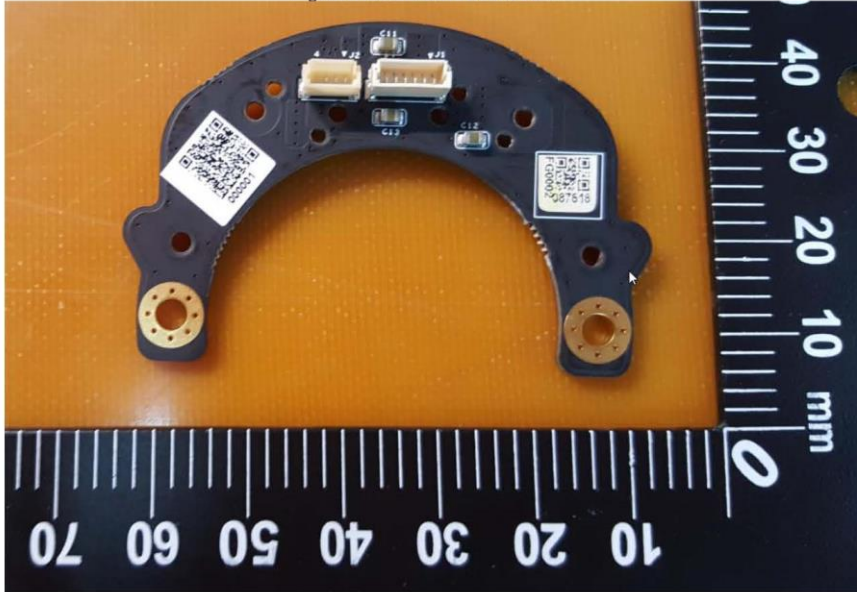

Fig.10: Remote LED board view-2



Miscellaneous ID 4-02

Table: Additional Test Table

Page 1 of 3

Report No.: 4788944424-1

Table 6.1 Emission limits for risk groups of continuous wave lamps										P
Risk	Action spectrum	Symbol	Units	Emission Measurement						
				Exempt		Low risk		Mod risk		
				Limit	Result	Limit	Result	Limit	Result	
Actinic UV	$S_{UV}(\lambda)$	E_s	$W \cdot m^{-2}$	0,001	0.000E+00	0,003	0.000E+00	0,03	0.000E+00	
Near UV		E_{uVA}	$W \cdot m^{-2}$	10	0.000E+00	33	0.000E+00	100	0.000E+00	
Blue light	$B(\lambda)$	L_B	$W \cdot m^{-2} \cdot sr^{-1}$	100	1.045E-01	10000	4.067E+00	4000000	9.325E+00	
Blue light, small source	$B(\lambda)$	E_B	$W \cdot m^{-2}$	1,0*	-	1,0	-	400	-	
Retinal thermal	$R(\lambda)$	L_R	$W \cdot m^{-2} \cdot sr^{-1}$	6.112E+05	9.768E+03	6.112E+05	9.768E+03	1.550E+06	2.240E+04	
Retinal thermal, weak visual stimulus**	$R(\lambda)$	L_{IR}	$W \cdot m^{-2} \cdot sr^{-1}$	1.310E+05	9.563E+03	1.310E+05	9.563E+03	1.310E+05	9.563E+03	
IR radiation, eye		E_{IR}	$W \cdot m^{-2}$	100	7.461E+00	570	7.461E+00	3200	7.461E+00	

* Small source defined as one with $\alpha < 0,011$ radian. Averaging field of view at 10000 s is 0,1 radian.
** Involves evaluation of non-GLS source
Angular subtense of apparent source: $\alpha = 45.81$ mrad
Test condition: Fault condition (driving LED by 1.5A/5.277V directly) for fix LED board.
Conclusion: Infrared LEDs (LD3, LD5): Lextar / PR35F0A (370015500G), were assigned as Exempt Group.

Miscellaneous ID 4-02

Table: Additional Test Table

Page 2 of 3

Report No.: 4788944424-1

Table 6.1 Emission limits for risk groups of continuous wave lamps									P
Risk	Action spectrum	Symbol	Units	Emission Measurement					
				Exempt		Low risk		Mod risk	
				Limit	Result	Limit	Result	Limit	Result
Actinic UV	$S_{UV}(\lambda)$	E_s	$W \cdot m^{-2}$	0,001	0.000E+00	0,003	0.000E+00	0,03	0.000E+00
Near UV		E_{UVA}	$W \cdot m^{-2}$	10	0.000E+00	33	0.000E+00	100	0.000E+00
Blue light	$B(\lambda)$	L_B	$W \cdot m^{-2} \cdot sr^{-1}$	100	6.705E-02	10000	2.061E+00	4000000	2.556E+00
Blue light, small source	$B(\lambda)$	E_B	$W \cdot m^{-2}$	1,0*	-	1,0	-	400	-
Retinal thermal	$R(\lambda)$	L_R	$W \cdot m^{-2} \cdot sr^{-1}$	3.436E+05	4.436E+03	3.436E+05	4.436E+03	8.712E+05	5.500E+03
Retinal thermal, weak visual stimulus**	$R(\lambda)$	L_{IR}	$W \cdot m^{-2} \cdot sr^{-1}$	7.363E+04	4.345E+03	7.363E+04	4.345E+03	7.363E+04	4.345E+03
IR radiation, eye		E_{IR}	$W \cdot m^{-2}$	100	1.366E+01	570	1.366E+01	3200	1.366E+01

* Small source defined as one with $\alpha < 0,011$ radian. Averaging field of view at 10000 s is 0,1 radian.
** Involves evaluation of non-GLS source
Angular subtense of apparent source: $\alpha=45.81$ mrad
Test condition: Normal condition (CW mode) for remote LED board
Conclusion: Infrared LED (LD1): Lextar / PR88F03 (370014700G) & LED (LD2): Lextar / PR88F03 (370014700G) & LED (LD3): Lextar / PR35F0A (370015500G) & LED (LD4): Lextar / PR35F0A (370015500G), were assigned as Exempt Group.

Miscellaneous ID 4-02

Table: Additional Test Table

Page 3 of 3

Report No.: 4788944424-1

Table 6.1 Emission limits for risk groups of continuous wave lamps										P
Risk	Action spectrum	Symbol	Units	Emission Measurement						
				Exempt		Low risk		Mod risk		
				Limit	Result	Limit	Result	Limit	Result	
Actinic UV	$S_{UV}(\lambda)$	E_s	$W \cdot m^{-2}$	0,001	0.000E+00	0,003	0.000E+00	0,03	0.000E+00	
Near UV		E_{uVA}	$W \cdot m^{-2}$	10	0.000E+00	33	0.000E+00	100	0.000E+00	
Blue light	$B(\lambda)$	L_B	$W \cdot m^{-2} \cdot sr^{-1}$	100	1.341E-01	10000	4.122E+00	4000000	5.112E+00	
Blue light, small source	$B(\lambda)$	E_B	$W \cdot m^{-2}$	1,0*	-	1,0	-	400	-	
Retinal thermal	$R(\lambda)$	L_R	$W \cdot m^{-2} \cdot sr^{-1}$	3.436E+05	8.872E+03	3.436E+05	8.872E+03	8.712E+05	1.100E+04	
Retinal thermal, weak visual stimulus**	$R(\lambda)$	L_{IR}	$W \cdot m^{-2} \cdot sr^{-1}$	7.363E+04	8.690E+03	7.363E+04	8.690E+03	7.363E+04	8.690E+03	
IR radiation, eye		E_{IR}	$W \cdot m^{-2}$	100	2.732E+01	570	2.732E+01	3200	2.732E+01	

* Small source defined as one with $\alpha < 0,011$ radian. Averaging field of view at 10000 s is 0,1 radian.

** Involves evaluation of non-GLS source

Angular subtense of apparent source: $\alpha = 45.81$ mrad

Test condition: Fault condition (driving LEDs (LD1 & LD2) by 4.0A/7.41V directly & LEDs (LD3 & LD4) by 1.5A/4.81V directly) for remote LED board.

Conclusion: Infrared LED (LD1): Lextar / PR88F03 (370014700G) & LED (LD2): Lextar / PR88F03 (370014700G) & LED (LD3): Lextar / PR35F0A (370015500G) & LED (LD4): Lextar / PR35F0A (370015500G), were assigned as Exempt Group.

Miscellaneous ID 4-03



TEST REPORT



Report No.: HC60144/2019
 Page: 1 of 7
 Date: July 1, 2019

VIVOTEK INC.
 6F., NO. 192, LIEN-CHENG RD., CHUNG-HO,
 NEW TAIPEI CITY, TAIWAN, R.O.C.

The following merchandise was submitted and identified by the vendor as:

Product Description: IP CAMERA
Style/ Item No.: FD9387-HV/ No.1
Manufacturer/ Vendor: Vivotek Inc.
Country of Origin: Taiwan
Quantity: Total 1 piece
Testing Period: Jun. 25, 2019 to Jun. 28, 2019
Note: (Client's declaration) The other styles used the identical enclosure with FD9387-HV are shown in appendix I

We have tested the submitted sample(s) as requested and the following results were obtained:

Test Required:

Test for Degrees of Protection Provided by Enclosures (IEC 60529 Edition 2.2: 2013)

IP Code	IP66
First characteristic numeral	Degrees of protection against access to hazardous parts and against solid foreign objects
Second characteristic numeral	Degrees of protection against ingress of water

Test Results:

Conclusion
Submittals sample(s) comply with the requirement and acceptance conditions of IEC 60529 Edition 2.2: 2013 Degrees of Protection Provided by Enclosures--IP66 The detailed description of test result, please see attached sheet(s).

SGS TAIWAN Ltd.

Ivan Wang

Ivan Wang
 Team Leader

Unless otherwise stated the results shown in this test report refer only to the sample(s) tested and such sample(s) are retained for 90 days only. This test report cannot be reproduced, except in full, without prior written permission of the Company. 除非另有說明，此報告結果僅對測試之樣品負責，同時此樣品僅保留90天，本報告未經本公司書面許可，不可部份複製。
 This document is issued by the Company subject to its General Conditions of Service printed overleaf, available on request or accessible at www.sgs.com/terms_and_conditions.htm and, for electronic format documents, subject to Terms and Conditions for Electronic Documents at www.sgs.com/terms_e-document.htm. Attention is drawn to the limitation of liability, indemnification and jurisdiction issues defined therein. Any holder of this document is advised that information contained hereon reflects the Company's findings at the time of its intervention only and within the limits of Client's instructions, if any. The Company's sole responsibility is to its Client and this document does not exonerate parties to a transaction from exercising all their rights and obligations under the transaction documents. This document cannot be reproduced except in full, without prior written approval of the Company. Any unauthorized alteration, forgery or falsification of the content or appearance of this document is unlawful and offenders may be prosecuted to the fullest extent of the law.

SGS Taiwan Ltd.
 台灣檢驗科技股份有限公司

Reliability Laboratory/ No.31, Wu Chyuan Road, New Taipei Industrial Park, Wuku Distrid, New Taipei City, Taiwan
 可靠度實驗室/ 新北市五股區新北產業園區五權路31號
 t (886-2) 2289-3279 f (886-2) 2289-9568

www.tw.sgs.com
 Member of SGS Group

Miscellaneous ID 4-03



TEST REPORT

Report No.: HC60144/2019

Page: 2 of 7

Test for Degrees of Protection Provided by Enclosures:Test Equipment:

Name	Brand	Model	Serial No.
1.0 mm Test Wire Probe	ED&D	TRP-02	L12470907
Digital Force Gauge	ALGOL	HF-50	HF-106764
Dust Tester	T-MACHINE	TMJ-9723S	T-23-110708
IPX6 Water Jet Hose Nozzle Set	PTL	P03.28	5040045

Lab Environmental Conditions:Ambient temperature: (15 ~ 35)°CAmbient humidity: (25 ~ 75) % RH

Test Location: No.33, Wu Chyuan Road, New Taipei Industrial Park, WuKu District, New Taipei City, Taiwan

Test Method/ Specification:Test method: IEC 60529 Edition 2.2: 2013--IP66**1. Test for protection against access to hazardous parts:**

Test method: The test wire with 1.0 mm in diameter and 100 mm long is pushed against or inserted through any openings of the enclosure with designated force. Examine whether the test wire touches the hazardous live parts inside the enclosure or not.

Test force: 1 N±10 %**2. Test for protection against solid foreign objects:**Test method: Dust testSample condition: Non-OperatingCategory of enclosure: Category 1Type of dust: Talcum powderThe amount of dust: 2 kg per cubic meter of the chamber volumeThe maximum depression: < 20 mbarTest duration: 8 hours

- Examine the protection against ingress dust of specimen(s) after this test.

Unless otherwise stated the results shown in this test report refer only to the sample(s) tested and such sample(s) are retained for 90 days only. This test report cannot be reproduced, except in full, without prior written permission of the Company. 除非另有說明，此報告結果僅對測試之樣品負責，同時此樣品僅保留90天，本報告未經本公司書面許可，不可部份複製。
This document is issued by the Company subject to its General Conditions of Service printed overleaf, available on request or accessible at www.sgs.com/terms_and_conditions.htm and, for electronic format documents, subject to Terms and Conditions for Electronic Documents at www.sgs.com/terms_e-document.htm. Attention is drawn to the limitation of liability, indemnification and jurisdiction issues defined therein. Any holder of this document is advised that information contained hereon reflects the Company's findings at the time of its intervention only and within the limits of Client's instructions, if any. The Company's sole responsibility is to its Client and this document does not exonerate parties to a transaction from exercising all their rights and obligations under the transaction documents. This document cannot be reproduced except in full, without prior written approval of the Company. Any unauthorized alteration, forgery or falsification of the content or appearance of this document is unlawful and offenders may be prosecuted to the fullest extent of the law.

Miscellaneous ID 4-03



TEST REPORT

Report No.: HC60144/2019

Page: 3 of 7

Test Method/ Specification--Continued:**3. Test for protection against water:**Sample condition: Non-OperatingTest means: Spraying the enclosure from all practicable directions with a stream of water from a standard test nozzle as specified in test standard.

Internal diameter

of the nozzle: 12.5 mmDelivery rate: 100 l/minute ±5%

Distance from nozzle

to enclosure surface: between 2.5 m and 3 m

Core of the substantial

stream: circle of approximately 120 mm diameter at 2.5 m distance from nozzleTest duration: Total 3 minutes (Top/ Front face, each face 90 seconds)

- Examine the protection against ingress water of specimen after this test.

Unless otherwise stated the results shown in this test report refer only to the sample(s) tested and such sample(s) are retained for 90 days only. This test report cannot be reproduced, except in full, without prior written permission of the Company. 除非另有說明，此報告結果僅對檢驗之樣品負責，同時此樣品僅保留90天，本報告未經本公司書面許可，不可部份複製。

This document is issued by the Company subject to its General Conditions of Service printed overleaf, available on request or accessible at www.sgs.com/terms_and_conditions.htm and, for electronic format documents, subject to Terms and Conditions for Electronic Documents at www.sgs.com/terms_e-document.htm. Attention is drawn to the limitation of liability, indemnification and jurisdiction issues defined therein. Any holder of this document is advised that information contained hereon reflects the Company's findings at the time of its intervention only and within the limits of Client's instructions, if any. The Company's sole responsibility is to its Client and this document does not exonerate parties to a transaction from exercising all their rights and obligations under the transaction documents. This document cannot be reproduced except in full, without prior written approval of the Company. Any unauthorized alteration, forgery or falsification of the content or appearance of this document is unlawful and offenders may be prosecuted to the fullest extent of the law.

Miscellaneous ID 4-03



TEST REPORT

Report No.: HC60144/2019

Page: 4 of 7

Specimen:Style/ Item No.: FD9387-HV/ No.1Quantity: Total 1 pieceTest Result:

A. Degrees of protection against access to hazardous parts and against solid foreign objects (IP6X)

A-1 Test for protection against access to hazardous parts (IP6X)

Test Result		
Check Item		Style/ Item No.
		FD9387-HV/ No.1
1	Does the test wire penetrate any openings of the enclosure?	No
2	(followed check item 1) If the test wire penetrates any openings of the enclosure, does the test wire touch any hazardous live parts or any hazardous mechanical parts?	N/A
3	(followed check item 2) Does adequate clearance be kept between the test wire and hazardous live parts or hazardous mechanical parts?	N/A
Note 1: N/A means "Not Applicable".		
Note 2: The check items in this test report for inspecting the degree of protection provided by enclosures are reference to the requirements specified in IEC 60529 Edition 2.2: 2013 and in accordance with the acceptance conditions specified by client.		

A-2 Test for protection against solid foreign objects (IP6X)

Test Result		
Check Item		Style/ Item No.
		FD9387-HV/ No.1
1	Does any dust deposit inside the enclosure?	No
Note 1: N/A means "Not Applicable".		
Note 2: The check items in this test report for inspecting the degree of protection provided by enclosures are reference to the requirements specified in IEC 60529 Edition 2.2: 2013 and in accordance with the acceptance conditions specified by client.		

Unless otherwise stated the results shown in this test report refer only to the sample(s) tested and such sample(s) are retained for 90 days only. This test report cannot be reproduced, except in full, without prior written permission of the Company. 除非另有說明，此報告結果僅對測試之樣品負責，同時此樣品僅保留 90 天。本報告未經本公司書面許可，不可部份複製。

This document is issued by the Company subject to its General Conditions of Service printed overleaf, available on request or accessible at www.sgs.com/terms_and_conditions.htm and, for electronic format documents, subject to Terms and Conditions for Electronic Documents at www.sgs.com/terms_e-document.htm. Attention is drawn to the limitation of liability, indemnification and jurisdiction issues defined therein. Any holder of this document is advised that information contained herein reflects the Company's findings at the time of its intervention only and within the limits of Client's instructions, if any. The Company's sole responsibility is to its Client and this document does not exonerate parties to a transaction from exercising all their rights and obligations under the transaction documents. This document cannot be reproduced except in full, without prior written approval of the Company. Any unauthorized alteration, forgery or falsification of the content or appearance of this document is unlawful and offenders may be prosecuted to the fullest extent of the law.

SGS Taiwan Ltd.
台灣檢驗科技股份有限公司

Reliability Laboratory/ No.31, Wu Chyuan Road, New Taipei Industrial Park, WuKu District, New Taipei City, Taiwan
可靠度實驗室/ 新北市五股區新北產業園區五權路31號
t.(886-2) 2299-3279 f.(886-2) 2299-9558

www.tw.sgs.com
Member of SGS Group

Miscellaneous ID 4-03



TEST REPORT

Report No.: HC60144/2019

Page: 5 of 7

Test Result--Continued:

B. Degree of protection against ingress of water (IPX6)

Test Result		
Check Item		Style/ Item No.
		FD9387-HV/ No.1
1	Does any water enter the enclosure?	No
2	(followed check item 1) If any water has entered, does the water accumulate near the cable end or live parts?	N/A
2.1	(followed check item 2) Does the water be sufficient to interfere with the correct operation of the equipment or impair safety?	N/A
2.2	(followed check item 2.1) Does the water deposit on insulation parts where it could lead to tracking along the creepage distances?	N/A
2.3	(followed check item 2.2) Does the water reach live parts or windings not designed to operate when wet?	N/A
Note 1: N/A means "Not Applicable".		
Note 2: The check items in this test report for inspecting the degree of protection provided by enclosures are reference to the requirements specified in IEC 60529 Edition 2.2: 2013 and in accordance with the acceptance conditions specified by client.		

Unless otherwise stated the results shown in this test report refer only to the sample(s) tested and such sample(s) are retained for 90 days only. This test report cannot be reproduced, except in full, without prior written permission of the Company. 除非另有說明，此報告結果僅對測試之樣品負責，同時此樣品僅保留90天。本報告未經本公司書面許可，不可部份複製。
This document is issued by the Company subject to its General Conditions of Service printed overleaf, available on request or accessible at www.sgs.com/terms_and_conditions.htm and for electronic format documents, subject to Terms and Conditions for Electronic Documents at www.sgs.com/terms_e-document.htm. Attention is drawn to the limitation of liability, indemnification and jurisdiction issues defined therein. Any holder of this document is advised that information contained hereon reflects the Company's findings at the time of its intervention only and within the limits of Client's instructions, if any. The Company's sole responsibility is to its Client and this document does not exonerate parties to a transaction from exercising all their rights and obligations under the transaction documents. This document cannot be reproduced except in full, without prior written approval of the Company. Any unauthorized alteration, forgery or falsification of the content or appearance of this document is unlawful and offenders may be prosecuted to the fullest extent of the law.

SGS Taiwan Ltd.
台灣檢驗科技股份有限公司

Reliability Laboratory/ No.31, WU Chyuan Road, New Taipei Industrial Park, Wuku District, New Taipei City, Taiwan
可靠度實驗室/ 新北市五股區新北產業園區五權路31號
T (886-2) 2299-3279 F (886-2) 2299-9558

www.tai.sgs.com
Member of SGS Group

Miscellaneous ID 4-03



TEST REPORT

Report No.: HC60144/2019

Page: 6 of 7

Appendix I (styles declaration by client):

FD9365-HTV-A、FD9365-EHTV-A、FD9387-HTV-A、FD9387-EHTV-A、FD9365-HTVL、
 FD9387-HTV、FD9387-EHV、FD9387-EHTV、FD9387-HV(AC)、FD9387-HTV(AC)、
 FD9387-HTV(W/O LOGO)、FD9387-EHV(AC)、FD9387-EHTV(AC)、FD9387-HVTPM、
 FD9367-EHTV、FD9367-HTV、FD9367-HV、FD9367-HTV(EPOC)、FD9367-HV(W/O IR)、
 FD9367-HV(W/O MIC)、FD8377-EHTV、FD8377-HTV、FD9371-EHTV、FD9371-HTV、
 FD9371-HTV(TILT 80)、FD9381-EHTV and FD9381-HTV

Unless otherwise stated the results shown in this test report refer only to the sample(s) tested and such sample(s) are retained for 90 days only. This test report cannot be reproduced, except in full, without prior written permission of the Company. 除非另有說明，此報告結果僅對測試之樣品負責，同時此樣品僅保留90天。本報告未經本公司書面許可，不可部份複製。
 This document is issued by the Company subject to its General Conditions of Service printed overleaf, available on request or accessible at www.sgs.com/terms_and_conditions.htm and for electronic format documents, subject to Terms and Conditions for Electronic Documents at www.sgs.com/terms_e-document.htm. Attention is drawn to the limitation of liability, indemnification and jurisdiction issues defined therein. Any holder of this document is advised that information contained hereon reflects the Company's findings at the time of its intervention only and within the limits of Client's instructions, if any. The Company's sole responsibility is to its Client and this document does not exonerate parties to a transaction from exercising all their rights and obligations under the transaction documents. This document cannot be reproduced except in full, without prior written approval of the Company. Any unauthorized alteration, forgery or falsification of the content or appearance of this document is unlawful and offenders may be prosecuted to the fullest extent of the law.

SGS Taiwan Ltd.
 台灣檢驗科技股份有限公司

Reliability Laboratory/ No.31, Wlu Chyuan Road, New Taipei Industrial Park, Wuku District, New Taipei City, Taiwan
 可靠度實驗室/ 新北市五股區新北產業園區五權路31號
 T: (886-2) 2299-3279 F: (886-2) 2299-9558

www.tw.sgs.com
 Member of SGS Group

Miscellaneous ID 4-03



TEST REPORT

Report No.: HC60144/2019

Page: 7 of 7

Test Photos:

1. Appearance of specimen	2. Appearance of specimen
3. Test for protection against solid foreign objects (Dust test)	4. Test for protection against water

— — — The End of Test Report — — —

Unless otherwise stated the results shown in this test report refer only to the sample(s) tested and such sample(s) are retained for 90 days only. This test report cannot be reproduced, except in full, without prior written permission of the Company. 除非另有說明，此報告結果僅對測試之樣品負責，同時此樣品僅保留 90 天。本報告未經本公司書面許可，不可部份複製。

This document is issued by the Company subject to its General Conditions of Service printed overleaf, available on request or accessible at www.sgs.com/terms_and_conditions.htm and, for electronic format documents, subject to Terms and Conditions for Electronic Documents at www.sgs.com/terms_e-document.htm. Attention is drawn to the limitation of liability, indemnification and jurisdiction issues defined therein. Any holder of this document is advised that information contained hereon reflects the Company's findings at the time of its intervention only and within the limits of Client's instructions, if any. The Company's sole responsibility is to its Client and this document does not exonerate parties to a transaction from exercising all their rights and obligations under the transaction documents. This document cannot be reproduced except in full, without prior written approval of the Company. Any unauthorized alteration, forgery or falsification of the content or appearance of this document is unlawful and offenders may be prosecuted to the fullest extent of the law.