



CE EMC Test Report

Issued date: Jan. 23, 2017

Project No.: 16Q122214

Product : Network Camera

Model : FD816CA-HF2

Applicant : VIVOTEK INC.

Address : 6F, No.192, Lien-Cheng Rd., Chung-Ho, New Taipei City, 235,
Taiwan, R.O.C.

Report No: WD-EE-R-160211-00

According to

EN55032: 2012 + AC:2013, Class B

CISPR 32: 2012

EN55022: 2010 +AC:2011, Class B

CISPR 22: 2008 (Ed 6.0)

EN 61000-3-2: 2014

EN 61000-3-3: 2013

EN55024: 2010 + A1:2015

IEC 61000-4-2: 2008 (Ed 2.0)

IEC 61000-4-3: 2010 (Ed 3.2)

IEC 61000-4-4: 2012 (Ed 3.0)

IEC 61000-4-5: 2014 (Ed 3.0)

IEC 61000-4-6: 2013 (Ed 4.0)

IEC 61000-4-8: 2009 (Ed 2.0)

IEC 61000-4-11: 2004 (Ed 2.0)

Technical Engineer : Evan Cheng / Evan Cheng

Authorized Signatory : Ken Huang / Ken Huang

Wendell Industrial Co., Ltd

Wendell Electronic Test Laboratory

Addr: 6F/6F-1, No.188, Baoqiao Rd., Xindian Dist., New Taipei City 23145, Taiwan R.O.C.



Table of Contents

- 1 Certification 6**
 - 1.1 Summary of Test Result..... 7**
- 2 Test Configuration of Equipment Under Test 8**
 - 2.1 Test Facility..... 8**
 - 2.2 Measurement Uncertainty 9**
 - 2.2.1 Conducted Emission test..... 9
 - 2.2.2 Conducted emission at telecom port test 9
 - 2.2.3 Radiated Emission test..... 9
 - 2.2.4 Harmonics Current Measurement 9
 - 2.2.5 Voltage Fluctuation and Flicker Measurement..... 10
 - 2.2.6 Immunity Test..... 10
- 3 Generation Information 11**
 - 3.1 Description of EUT..... 11**
 - 3.2 Description of Test Modes..... 12**
 - 3.3 EUT Operating Condition 12**
 - 3.4 Description of Support Unit 13**
 - 3.5 Configuration of System Under Test..... 13**
- 4 Emission Test..... 14**
 - 4.1 Conducted Emission Measurement (Frequency Range 150 KHz-30MHz)..... 14**
 - 4.2 Conducted Emission at Telecommunication Ports Test 15**
 - 4.2.1 Limit of Conducted Emission at Telecommunication Ports Test..... 15
 - 4.2.2 Test Instrument 17
 - 4.2.3 Test Procedure..... 18
 - 4.2.4 Deviation from Test Standard 18
 - 4.2.5 Test Setup..... 19
 - 4.2.6 Test Result 20
 - 4.2.7 Photographs of Test Configuration 24
 - 4.3 Radiated Emission Measurement 26**
 - 4.3.1 Limits of Radiated Emission Measurement 26
 - 4.3.2 Test Instrument 29
 - 4.3.3 Test Procedure..... 30
 - 4.3.4 Deviation from Test Standard 30
 - 4.3.5 Test Setup..... 31
 - 4.3.6 Test Result 33
 - 4.3.7 Photographs of Test Configuration 41
 - 4.4 Harmonics Current Measurement..... 45**
 - 4.5 Voltage Fluctuation and Flicker Measurement 46**
- 5 Immunity Test 47**
 - 5.1 Standard Description 47**
 - 5.2 Performance Criteria 48**
 - 5.3 Electrostatic Discharge (ESD)..... 49**
 - 5.3.1 Test Specification..... 49
 - 5.3.2 Test Instrument 49
 - 5.3.3 Test Procedure..... 50
 - 5.3.4 Deviation from Test Standard 51



5.3.5	Test Setup.....	51
5.3.6	Test Result	52
5.3.7	Photographs of Test Configuration	56
5.4	Radiated, Radio-frequency, Electromagnetic Field Immunity Test (RS).....	57
5.4.1	Test Specification.....	57
5.4.2	Test Instrument	57
5.4.3	Test Procedure.....	58
5.4.4	Deviation from Test Standard	58
5.4.5	Test Setup.....	59
5.4.6	Test Result	60
5.4.7	Photographs of Test Configuration	61
5.5	Electrical Fast Transient /Burst Immunity Test (EFT).....	64
5.5.1	Test Specification.....	64
5.5.2	Test Instrument	64
5.5.3	Test Procedure.....	65
5.5.4	Deviation from Test Standard	65
5.5.5	Test Setup.....	66
5.5.6	Test Result	67
5.5.7	Photographs of Test Configuration	68
5.6	Surge Immunity Test.....	69
5.6.1	Test Specification.....	69
5.6.2	Test Instrument	69
5.6.3	Test Procedure.....	70
5.6.4	Deviation from Test Standard	70
5.6.5	Test Setup.....	70
5.6.6	Test Result	71
5.6.7	Photographs of Test Configuration	72
5.7	Continuous Conducted Disturbances (CS)	73
5.7.1	Test Specification.....	73
5.7.2	Test Instrument	73
5.7.3	Test Procedure.....	73
5.7.4	Deviation from Test Standard	74
5.7.5	Test Setup.....	74
5.7.6	Test Result	75
5.7.7	Photographs of Test Configuration	76
5.8	Power Frequency Magnetic Field Immunity Test	77
5.8.1	Test Specification.....	77
5.8.2	Test Instrument	77
5.8.3	Test Procedure.....	77
5.8.4	Deviation from Test Standard	77
5.8.5	Test Setup.....	78
5.8.6	Test Result	79
5.8.7	Photographs of Test Configuration	80
5.9	Voltage Dips & Short Interruptions	81



History of this test report

Report No.	Issue date	Description
WD-EE-R-160211-00	Jan. 23, 2017	Initial Issue

Declaration

This report is for your exclusive use. Any copying or replication of this report to or for any other person or entity, or use of our name or trademark, is permitted only with our prior written permission. This report sets forth our findings solely with respect to the test samples identified herein. The results set forth in this report are not indicative or representative of the quality or characteristics of the lot from which a test sample was taken or any similar or identical product unless specifically and expressly noted. Our report includes all of the tests requested by you and the results thereof based upon the information that you provided to us.



History of supplementary report

Report No.	Issue date	Description
WD-EE-R-160167-00	Nov. 24, 2016	Original report
WD-EE-R-160211-00	Jan. 23, 2017	Update standard

Declaration

This report is for your exclusive use. Any copying or replication of this report to or for any other person or entity, or use of our name or trademark, is permitted only with our prior written permission. This report sets forth our findings solely with respect to the test samples identified herein. The results set forth in this report are not indicative or representative of the quality or characteristics of the lot from which a test sample was taken or any similar or identical product unless specifically and expressly noted. Our report includes all of the tests requested by you and the results thereof based upon the information that you provided to us.



1 Certification

Product: Network Camera
Brand Name: VIVOTEK
Model No: FD816CA-HF2
Applicant: VIVOTEK INC.
Tested: Oct. 28 ~ Nov. 07, 2016 (for EN55022, EN55024)
Jan. 04 ~ Jan. 06, 2017 (for EN55032)
Standard: **EN55032: 2012 + AC:2013, Class B**
CISPR 32: 2012
EN 55022: 2010 +AC: 2011, Class B
CISPR 22: 2008 (Ed 6.0)
EN 61000-3-2: 2014
EN 61000-3-3: 2013
EN 55024: 2010 + A1:2015
IEC 61000-4-2: 2008
IEC 61000-4-3: 2010
IEC 61000-4-4: 2012
IEC 61000-4-5: 2014
IEC 61000-4-6: 2013
IEC 61000-4-8: 2009
IEC 61000-4-11: 2004

The above equipment (Model: FD816CA-HF2) has been tested by **Wendell Electrical Test Laboratory**, and found compliance with the requirement of the above standards. The test record, data evaluation and Equipment Under Test (EUT) configurations represented herein are true and accurate accounts of the measurements of the sample's EMC characteristics under the conditions specified in this report.

1.1 Summary of Test Result

The EUT has been tested according to the following specifications:

Emission				
Standard	Test Item	Limit	Result	Remark
EN 55032 EN 55022	Conducted disturbance at mains terminals	-	N/A	Without AC power port of the EUT
CISPR 32 CISPR 22	Conducted disturbance at telecommunication ports test	Class B	Pass	Meets the requirements
	Radiated disturbance	Class B	Pass	Meets the requirements
EN 61000-3-2	Harmonic current emissions	-	N/A	Without AC power port of the EUT
EN 61000-3-3	Voltage fluctuations and flicker	-	N/A	Without AC power port of the EUT

Immunity			
Standard	Test Item	Result	Remark
IEC 61000-4-2	Electrostatic discharges (ESD)	Pass	Meets the requirements of Performance Criterion B
IEC 61000-4-3	Continuous radiated disturbances (RS)	Pass	Meets the requirements of Performance Criterion A
IEC 61000-4-4	Electrical fast transients (EFT)	Pass	Meets the requirements of Performance Criterion A
IEC 61000-4-5	Surges	Pass	Meets the requirements of Performance Criterion B
IEC 61000-4-6	Continuous conducted disturbances(CS)	Pass	Meets the requirements of Performance Criterion A
IEC 61000-4-8	Power-frequency magnetic fields (PFMF)	Pass	Meets the requirements of Performance Criterion A
IEC 61000-4-11	Voltage dips and interruptions	N/A	Without AC power port of the EUT

Note: Test record contained in the referenced test report relate only to the EUT sample and test item.

2 Test Configuration of Equipment Under Test

2.1 Test Facility

Conducted disturbance at mains terminals, Conducted disturbance at telecommunication ports, Harmonics, Flicker and Immunity Tests

W01: Add: 6F/6F-1, No.188, Baoqiao Rd., Xindian Dist., New Taipei City 23145, Taiwan
R.O.C.

Radiated emission Test (OATS)

W03: No.38-20, Mujiliao, Sanzhi Dist., New Taipei City 252, Taiwan (R.O.C.)

ACCREDITATIONS

The laboratories are accredited and approved by the TAF according to ISO/IEC 17025.

2.2 Measurement Uncertainty

The measurement instrumentation uncertainty consideration contained in CISPR 16-4-2.

This uncertainty represents an expanded uncertainty expressed at approximately the 95% confidence level using a coverage factor of $k=2$.

2.2.1 Conducted Emission test

Test Site	Measurement Freq. Range	dB (U_{cispr})	Note
W01	150 kHz ~ 30 MHz	3.19	N/A

2.2.2 Conducted emission at telecom port test

Test Site	Measurement Freq. Range	dB (U_{cispr})	Note
W01	150 kHz ~ 30 MHz	3.16	N/A

2.2.3 Radiated Emission test

Test Site	Measurement Freq. Range	Ant	dB (U_{cispr})	Note
W03	30 MHz ~ 200 MHz	V	4.29	N/A
	30 MHz ~ 200 MHz	H	3.35	N/A
	200 MHz ~ 1000 MHz	V	3.87	N/A
	200 MHz ~ 1000 MHz	H	3.48	N/A
	1 GHz ~ 3 GHz	V	4.47	N/A
	1 GHz ~ 3 GHz	H	4.44	N/A
	3 GHz ~ 6 GHz	V	4.86	N/A
	3 GHz ~ 6 GHz	H	4.47	N/A

2.2.4 Harmonics Current Measurement

Test Site	Expanded Uncertainty	
W01	Voltage	3.96 V
	Current	1.18 mA
	Power	0.15 Hz

2.2.5 Voltage Fluctuation and Flicker Measurement

Test Site	Expanded Uncertainty	
W01	d_c, d_{max}	11.56 %
	P_{st}, P_{lt}	5.77 %

2.2.6 Immunity Test

Test Site	Item	Expanded Uncertainty		Note
W01	Electrostatic Discharge (ESD)	Voltage	0.05%	N/A
		Timing	5.6%	
	Continuous radiated disturbances (RS)	80MHz – 2.5GHz	3.0dB	80MHz - 1GHz, k=2
	Electrical fast transients (EFT)	Voltage	8.5%	N/A
		Timing	4.4%	
	Surges	Voltage	3.9%	N/A
		Current	2.9%	
		Time	3.7%	
	Continuous conducted disturbances (CS)	CDN	1.80dB	150KHz – 80MHz, k=2
		EM Clamp	3.75dB	
	Power-frequency magnetic fields (PFMF)	Magnetic Field Strength	1.0%	N/A
	Voltage dips and interruptions	Voltage	3.8%	N/A
		Current	2.4%	
		Time	2.0%	

3 Generation Information

3.1 Description of EUT

Product	Network Camera
Brand	VIVOTEK
Model No.	FD816CA-HF2
Applicant	VIVOTEK INC.
EUT Power Rating	48 Vdc (from POE)
Model Differences	N/A
Operating System	N/A
Data Cable Supplied	N/A
Accessory Device	N/A
I/O Port	Please refer to the User's Manual

Note:

1. The EUT's highest operating frequency is 800MHz. Therefore the radiated emission is tested up to 6GHz.

3.2 Description of Test Modes

Test results are presented in the report as below.

Test Result	Test Condition
Conducted emission test at telecom port test	
A	POE mode, LAN (10Mbps/100Mbps), (for EN 55022)
B	POE mode, LAN (10Mbps/100Mbps), (for EN 55032)
Radiated emission 30MHz ~ 1GHz test	
A	POE mode (for EN 55022)
B	POE mode (for EN 55032)
Radiated emission above 1GHz test	
A	POE mode (for EN 55022)
B	POE mode (for EN 55032)
ESD, RS, EFT, Surge, CS and PFMF test	
-	POE mode

3.3 EUT Operating Condition

- a. Placed the EUT on the test table.
- b. Prepared server PC and POE injector to act as a communication partner and placed it outside of testing area.
- c. The EUT was connected to the server PC via LAN cable and POE.
- d. The communication partner sent data to EUT by command "PING" via LAN.
- e. The server PC shows EUT's image on browser.
- f. The EUT write data with micro SD card.

3.4 Description of Support Unit

The EUT has been conducted testing with other necessary accessories or support units.

Item	Equipment	Brand	Model No.	Serial No.	FCC ID	Data Cable	Power Cord	Remark
1	Server PC	DELL	OPTIPLEX 380	2C6742S	FCC DoC Approved	1m non-shielded RJ45 cable	1.8m non-shielded cable	-
2	MicroSD Card	ADATA	16GB	N/A	N/A	N/A	N/A	-

- Note:**
1. The core(s) is(are) originally attached to the cable(s).
 2. Item 1 acted as communication partners to transfer data.
 3. The EUT uses the follow POE:

POE Injector (Support unit only)	
Brand	GeoVision
Model	GV-PA481
Input Power	100-240Vac, 2A
Output Power	48Vdc, 1A

3.5 Configuration of System Under Test

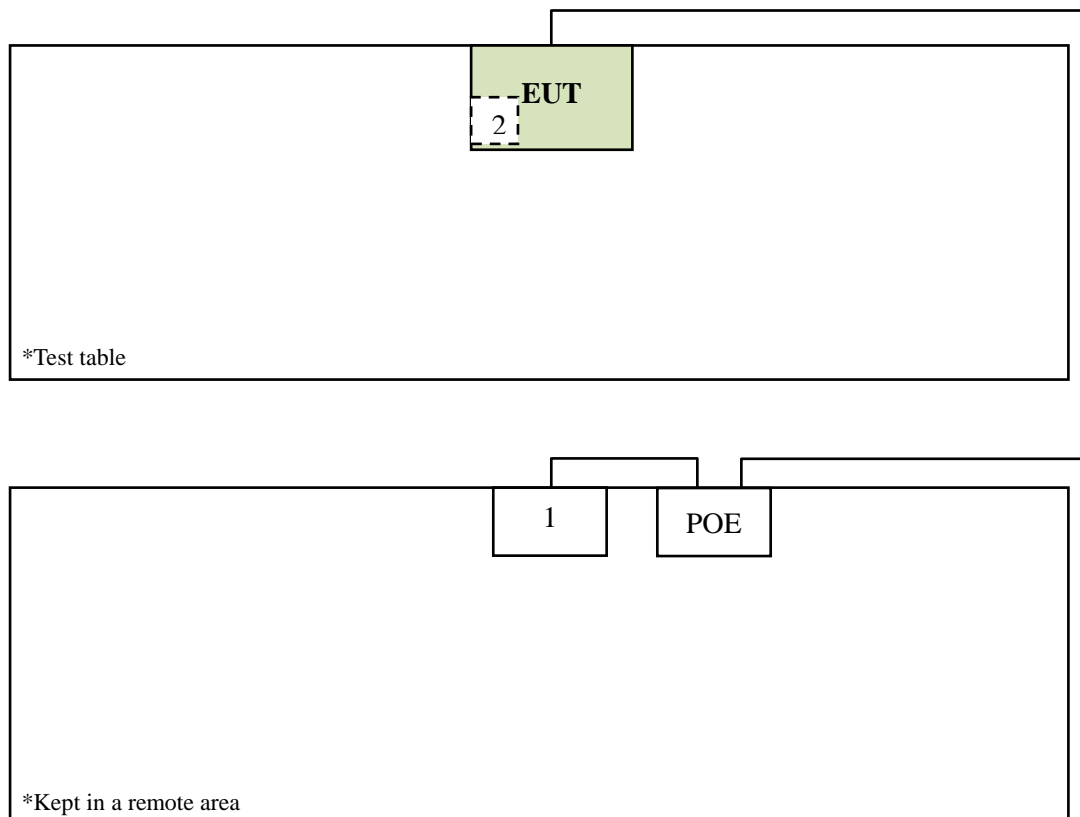



4 Emission Test

4.1 Conducted Emission Measurement (Frequency Range 150 KHz-30MHz)

The test is determined no necessary for the EUT do not operate from the power lines or contain provisions for operation while connected to the power lines.

4.2 Conducted Emission at Telecommunication Ports Test

4.2.1 Limit of Conducted Emission at Telecommunication Ports Test

Standard: EN 55022

Class A equipment

Frequency (MHz)	Voltage limits dB (uV)	
	Quasi-peak	Average
0.15 to 0.5	97 to 87	84 to 74
0.5 to 30	87	74

Note: The limits decrease linearly with the logarithm of the frequency in the range 0.15 MHz to 0.5 MHz.

Class B equipment

Frequency (MHz)	Voltage limits dB (uV)	
	Quasi-peak	Average
0.15 to 0.5	84 to 74	74 to 64
0.5 to 30	74	64

- Note:**
1. The lower limit shall apply at the transition frequencies.
 2. The limit decreases in line with the logarithm of the frequency in the range of 0.15 to 0.50 MHz.
 3. Detector function in the form: PK = Peak, QP = Quasi Peak, AV = Average
 4. The test result calculated as following:
Measurement Value = Reading Level + Correct Factor
Correction Factor = Insertion loss of ISN + Cable loss
Margin Level = Measurement Value – Limit Value

Standard: EN 55032

Class A equipment:

Requirements for asymmetric mode conducted emissions from Class A equipment			
Frequency (MHz)	Measurement		Class A limits dB(uV/m)
	Coupling device	Detector type/ bandwidth	
0.15 to 0.5	AAN	Quasi Peak / 9 kHz	97 to 87*
0.5 to 30			87
0.15 to 0.5	AAN	Average / 9 kHz	84 to 74*
0.5 to 30			74

* Decreases with the logarithm of the frequency.

Class B equipment:

Requirements for asymmetric mode conducted emissions from Class B equipment			
Frequency (MHz)	Measurement		Class B limits dB(uV/m)
	Coupling device	Detector type/ bandwidth	
0.15 to 0.5	AAN	Quasi Peak / 9 kHz	84 to 74*
0.5 to 30			74
0.15 to 0.5	AAN	Average / 9 kHz	74 to 64*
0.5 to 30			64

* Decreases with the logarithm of the frequency.

- Note:**
1. The lower limit shall apply at the transition frequencies.
 2. Detector function in the form: PK = Peak, QP = Quasi Peak, AV = Average
 3. The test result calculated as following:
 Measurement Value = Reading Level + Correct Factor
 Correction Factor = Insertion loss of ISN + Cable loss
 Margin Level = Measurement Value – Limit Value

4.2.2 Test Instrument

Item	Equipment	Manufacturer	Model	Meter No.	Calibration Date
1	TWO-LINE V-NETWORK	R&S	ENV216	CT-1-025-1	Mar. 29, 2016
2	EMI Test Receiver	R&S	ESCI	CT-01-024	Mar. 31, 2016
3	Impedance Stabilization Network	FCC	F-071115-10 57-1-09	CT-01-027	Mar. 30, 2016
4	TWO-LINE V-NETWORK	R&S	ENV216	CT-1-025-2	Mar. 29, 2016
5	Test Cable	HANRUIN	5D-FB	CT-1-069-1	Jul. 29, 2016
6	50ohm Termination	N/A	N/A	CT-1-065-2	Mar. 29, 2016
7	Measurement Software	EZ-EMC	Ver: FA-03A	CT-3-012	No calibration request

Note: 1. The calibration interval of the above test instruments is 12 months.

4.2.3 Test Procedure

- a. The EUT was placed 0.4 meter from the horizontal ground plane with EUT being connected to power source through a line impedance stabilization network (LISN). The LISN at least be 80 cm from nearest chassis of EUT.
- b. The line impedance stabilization network (LISN) provides 50 ohm/50uH of coupling impedance for the measuring instrument. All other support equipments powered from additional LISN(s).
- c. Interrelating cables that hang closer than 40 cm to the ground plane shall be folded back and forth in the center forming a bundle. All I/O cables were positioned to simulate typical usage.
- d. All I/O cables that are not connected to a peripheral shall be bundle in the center. The end of the cable may be terminated, if required, using the correct terminating impedance. The overall length shall not exceed 1 m.
- e. ISN at least 80 cm from nearest chassis of EUT. The communication function of EUT was executed in normal condition. ISN was connected between EUT and associated equipment and ISN was connected directly to reference ground plane. The actual test configuration, please refer to EUT test photos.
- f. The receiver scanned from 150kHz to 30MHz for emissions in each of test modes. The test mode included 10Mbps, 100Mbps, 1Gbps and POE mode. Emission frequency and amplitude were recorded, recording at least six highest emissions.
- g. The EUT and cable configuration of the above highest emission levels were recorded. The test data of the worst case was recorded.

4.2.4 Deviation from Test Standard

No deviation



4.2.6 Test Result

Test Voltage	48Vdc (from POE)	Frequency Range	0.15-30 MHz
Environmental Conditions	23.5°C, 56% RH	6dB Bandwidth	9 kHz
Test Date	2016/10/28	Tested by	Eddy Tsai
Test Condition	LAN port with ISN (10Mbps)	Test mode	A

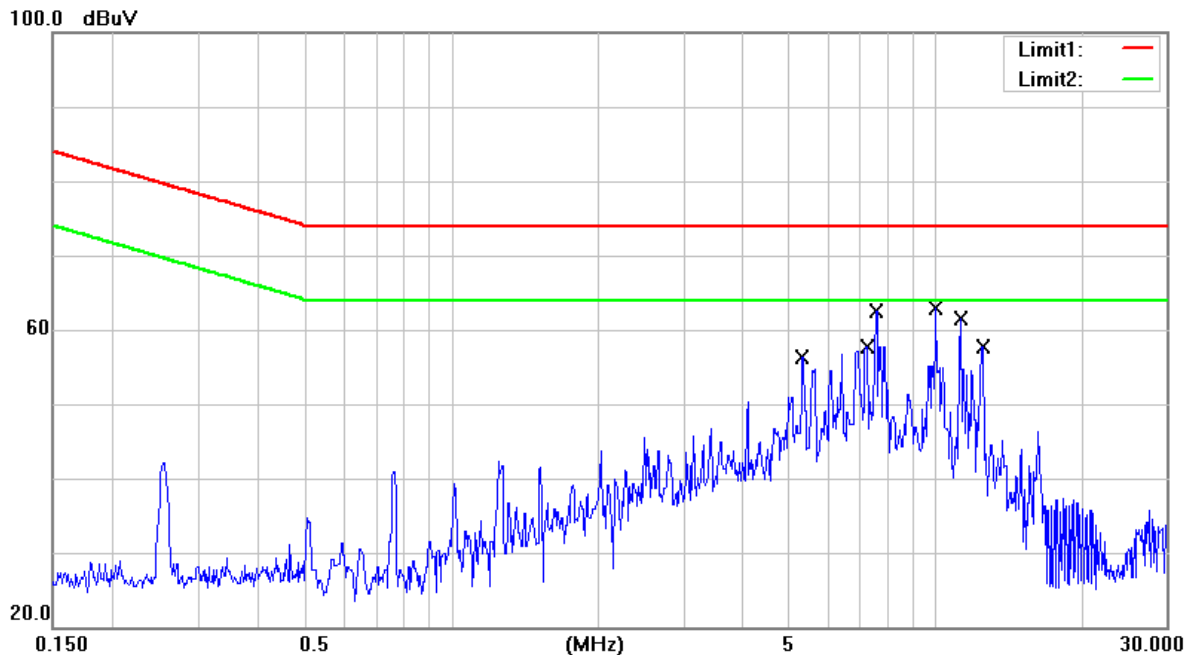

No.	Frequency (MHz)	Reading Level (dBuV)	Correct Factor (dB)	Measurement (dBuV)	Limit (dBuV)	Margin (dB)	Detector
1	5.3250	37.07	9.13	46.20	74.00	-27.80	QP
2	5.3250	27.45	9.13	36.58	64.00	-27.42	AVG
3	7.1750	31.80	9.15	40.95	74.00	-33.05	QP
4	7.1750	12.30	9.15	21.45	64.00	-42.55	AVG
5	7.5500	39.49	9.16	48.65	74.00	-25.35	QP
6	7.5500	22.08	9.16	31.24	64.00	-32.76	AVG
7	10.0000	46.41	9.19	55.60	74.00	-18.40	QP
8	10.0000	26.49	9.19	35.68	64.00	-28.32	AVG
9	11.2500	45.05	9.21	54.26	74.00	-19.74	QP
10	11.2500	25.94	9.21	35.15	64.00	-28.85	AVG
11	12.4500	35.68	9.22	44.90	74.00	-29.10	QP
12	12.4500	19.41	9.22	28.63	64.00	-35.37	AVG

Remark:

1. QP = Quasi Peak, AVG = Average
2. Correction Factor = Insertion loss of ISN + Cable loss
3. Measurement Value = Reading Level + Correct Factor
4. Margin Level = Measurement Value - Limit Value



Test Voltage	48Vdc (from POE)	Frequency Range	0.15-30 MHz
Environmental Conditions	23.5°C, 56% RH	6dB Bandwidth	9 kHz
Test Date	2016/10/28	Tested by	Eddy Tsai
Test Condition	LAN port with ISN (100Mbps)	Test mode	A

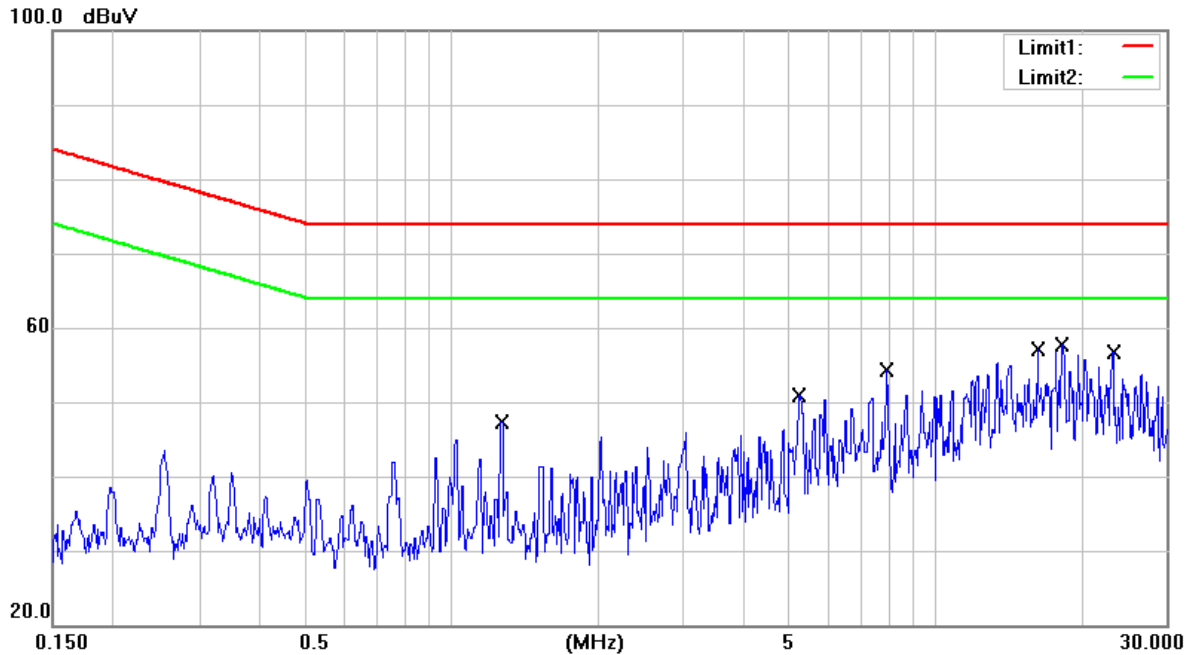

No.	Frequency (MHz)	Reading Level (dBuV)	Correct Factor (dB)	Measurement (dBuV)	Limit (dBuV)	Margin (dB)	Detector
1	1.2650	34.91	9.20	44.11	74.00	-29.89	QP
2	1.2650	31.10	9.20	40.30	64.00	-23.70	AVG
3	5.2250	22.84	9.13	31.97	74.00	-42.03	QP
4	5.2250	10.40	9.13	19.53	64.00	-44.47	AVG
5	7.9250	42.33	9.16	51.49	74.00	-22.51	QP
6	7.9250	40.56	9.16	49.72	64.00	-14.28	AVG
7	16.2250	46.58	9.27	55.85	74.00	-18.15	QP
8	16.2250	45.41	9.27	54.68	64.00	-9.32	AVG
9	18.2500	35.24	9.30	44.54	74.00	-29.46	QP
10	18.2500	32.59	9.30	41.89	64.00	-22.11	AVG
11	23.1500	30.80	9.41	40.21	74.00	-33.79	QP
12	23.1500	13.83	9.41	23.24	64.00	-40.76	AVG

Remark: 1. QP = Quasi Peak, AVG = Average
2. Correction Factor = Insertion loss of ISN + Cable loss
3. Measurement Value = Reading Level + Correct Factor
4. Margin Level = Measurement Value - Limit Value



Test Voltage	48Vdc (from POE)	Frequency Range	0.15-30 MHz
Environmental Conditions	23.1°C, 56% RH	6dB Bandwidth	9 kHz
Test Date	2017/01/04	Tested by	Guanwei Liao
Test Condition	LAN port with ISN (10Mbps)	Test mode	B

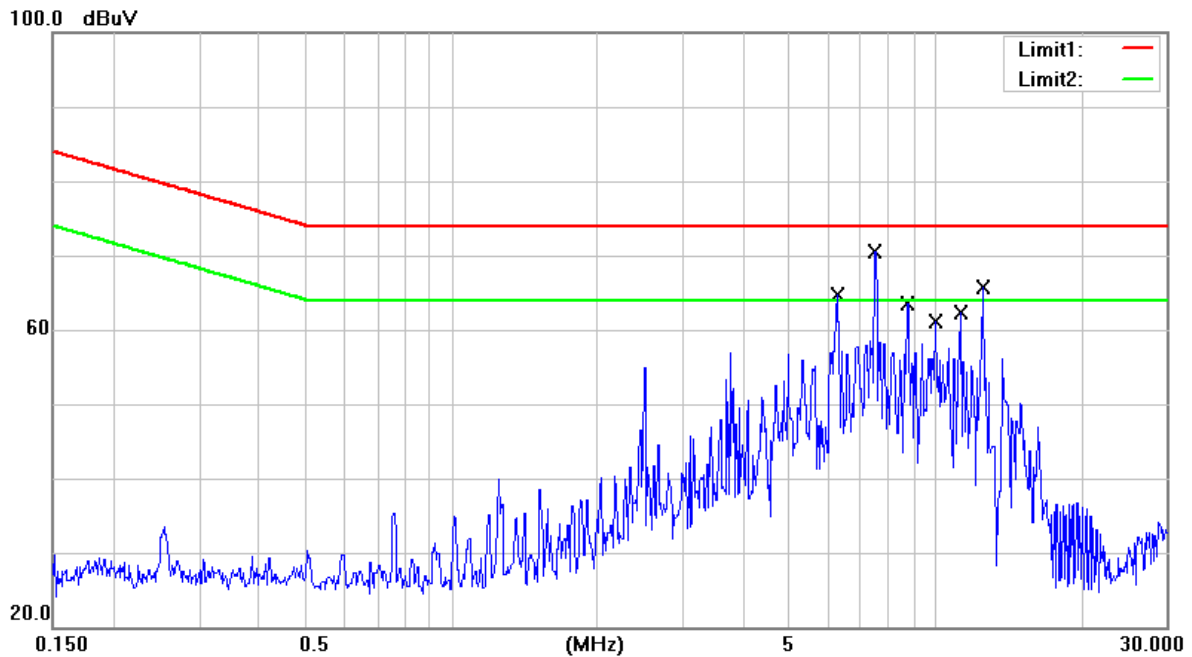

No.	Frequency (MHz)	Reading Level (dBuV)	Correct Factor (dB)	Measurement (dBuV)	Limit (dBuV)	Margin (dB)	Detector
1	6.2500	46.66	9.04	55.70	74.00	-18.30	QP
2	6.2500	37.88	9.04	46.92	64.00	-17.08	AVG
3	7.5000	52.16	9.04	61.20	74.00	-12.80	QP
4	7.5000	43.24	9.04	52.28	64.00	-11.72	AVG
5	8.7500	36.11	9.04	45.15	74.00	-28.85	QP
6	8.7500	7.79	9.04	16.83	64.00	-47.17	AVG
7	10.0000	44.71	9.05	53.76	74.00	-20.24	QP
8	10.0000	29.58	9.05	38.63	64.00	-25.37	AVG
9	11.2500	46.17	9.06	55.23	74.00	-18.77	QP
10	11.2500	37.33	9.06	46.39	64.00	-17.61	AVG
11	12.5000	49.57	9.08	58.65	74.00	-15.35	QP
12	12.5000	40.93	9.08	50.01	64.00	-13.99	AVG

Remark: 1. QP = Quasi Peak, AVG = Average
 2. Correction Factor = Insertion loss of ISN + Cable loss
 3. Measurement Value = Reading Level + Correct Factor
 4. Margin Level = Measurement Value - Limit Value



Test Voltage	48Vdc (from POE)	Frequency Range	0.15-30 MHz
Environmental Conditions	23.1°C , 56% RH	6dB Bandwidth	9 kHz
Test Date	2017/01/04	Tested by	Guanwei Liao
Test Condition	LAN port with ISN (100Mbps)	Test mode	B

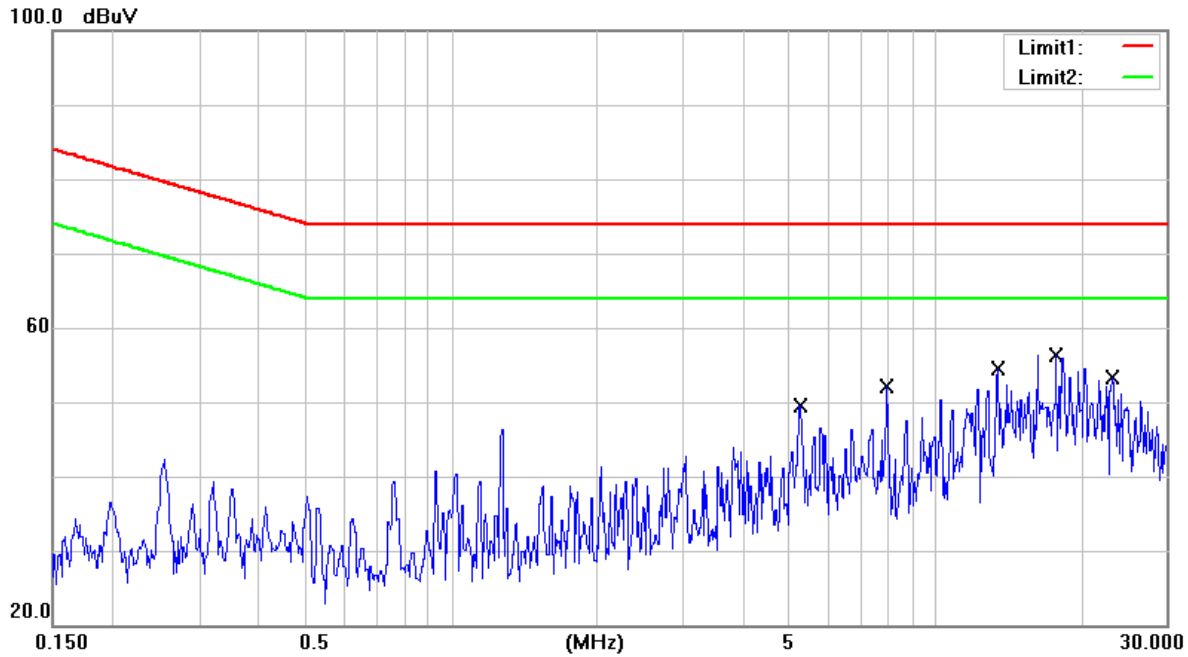

No.	Frequency (MHz)	Reading Level (dBuV)	Correct Factor (dB)	Measurement (dBuV)	Limit (dBuV)	Margin (dB)	Detector
1	5.2250	25.08	9.04	34.12	74.00	-39.88	QP
2	5.2250	17.64	9.04	26.68	64.00	-37.32	AVG
3	7.9250	41.29	9.04	50.33	74.00	-23.67	QP
4	7.9250	37.04	9.04	46.08	64.00	-17.92	AVG
5	13.3500	35.83	9.08	44.91	74.00	-29.09	QP
6	13.3500	30.13	9.08	39.21	64.00	-24.79	AVG
7	13.4250	38.36	9.08	47.44	74.00	-26.56	QP
8	13.4250	35.92	9.08	45.00	64.00	-19.00	AVG
9	17.7000	39.34	9.13	48.47	74.00	-25.53	QP
10	17.7000	37.42	9.13	46.55	64.00	-17.45	AVG
11	23.0750	35.12	9.21	44.33	74.00	-29.67	QP
12	23.0750	31.92	9.21	41.13	64.00	-22.87	AVG

Remark: 1. QP = Quasi Peak, AVG = Average
 2. Correction Factor = Insertion loss of ISN + Cable loss
 3. Measurement Value = Reading Level + Correct Factor
 4. Margin Level = Measurement Value - Limit Value

4.2.7 Photographs of Test Configuration

Test mode A



Test mode B

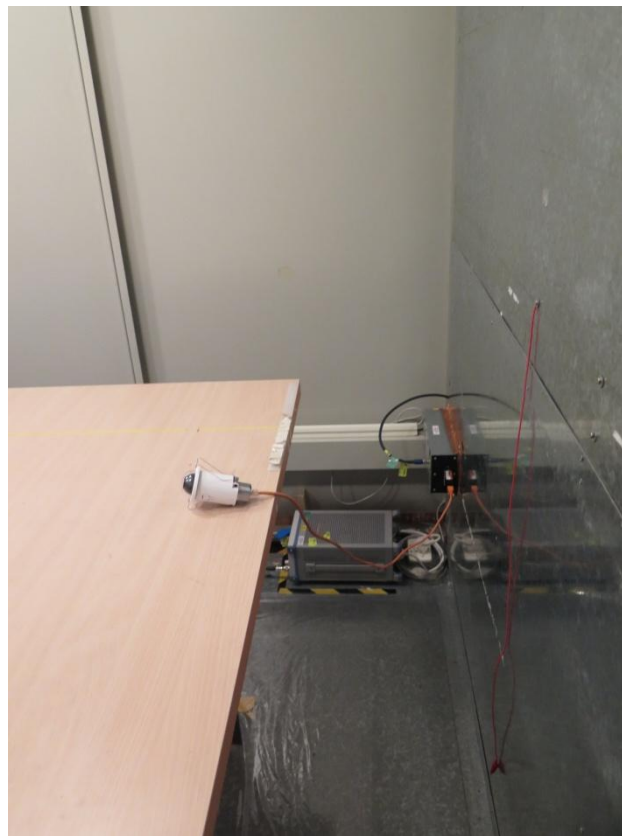

4.3 Radiated Emission Measurement

4.3.1 Limits of Radiated Emission Measurement

Standard: EN 55022

Radiated Frequency range 30 MHz to 1000 MHz

Frequency (MHz)	Class A (at 10m)	Class B (at 10m)
	dBuV/m	dBuV/m
30 to 230	40	30
230 to 1000	47	37

Note: 1. The lower limit shall apply at the transition frequency.

Radiated Frequency range above 1 GHz

Frequency (GHz)	Class A (at 3m)		Class B (at 3m)	
	Average (dBuV/m)	Peak (dBuV/m)	Average (dBuV/m)	Peak (dBuV/m)
1 to 3	56	76	50	70
3 to 6	60	80	54	74

- Note:**
- The lower limit shall apply at the transition frequency.
 - Detector function in the form: PK = Peak, QP = Quasi Peak, AV = Average
 - The test result calculated as following:
 Measurement Value = Reading Level + Correct Factor
 Correction Factor = Antenna factor + Cable loss (Antenna to preamplifier) - preamplifier Gain
 + Cable loss (preamplifier to receiver)
 Margin Level = Measurement Value - Limit Value
 - Maximum internal signal source is defined as the maximum frequency of the device under test, or EUT highest frequency tuning of the operation or in the production or use of the device under test.
 - If the maximum frequency of the device under test is less than the internal source of 108MHz, the only measure to 1GHz.
 - If the maximum frequency of the device between 108MHz and 500MHz maximum frequency of the device under test ranged from internal sources, you must measure to 2GHz.
 - If the maximum frequency of the device under test between internal source of 500MHz and 1GHz, you must measure to 5GHz.
 - If the maximum frequency of the device under test is higher than the internal source of 1GHz, it must measure up to the maximum frequency of 5 times or 6GHz, choosing the less.

Standard: EN 55032

According to EN55032 table1 - Required highest frequency for radiated measurement:

Highest internal frequency (F_x)	Highest measured frequency
$F_x \leq 108$ MHz	1 GHz
$108 \text{ MHz} < F_x \leq 500$ MHz	2 GHz
$500 \text{ MHz} < F_x \leq 1$ GHz	5 GHz
$F_x > 1$ GHz	$5 \times F_x$ up to a maximum of 6 GHz

Remark:

1. F_x : highest fundamental frequency generated or used within the EUT or highest frequency at which it operates.
2. Where F_x is unknown, the radiated emission measurements shall be performed up to 6 GHz.

Class A equipment:

Requirements for radiated emissions at frequencies up to 1 GHz for Class A equipment			
Frequency (MHz)	Measurement		Class A limits dB(uV/m)
	Distance (m)	Detector type/ bandwidth	OATS/SAC
30 to 230	10	Quasi Peak / 120 kHz	40
230 to 1000			47
30 to 230	3		50
230 to 1000			57

Requirements for radiated emissions at frequencies above 1 GHz for Class A equipment			
Frequency (MHz)	Measurement		Class A limits dB(uV/m)
	Distance (m)	Detector type/ bandwidth	FSOATS
1000 to 3000	3	Average / 1 MHz	56
3000 to 6000			60
1000 to 3000		Peak / 1 MHz	76
3000 to 6000			80



Class B equipment:

Requirements for radiated emissions at frequencies up to 1 GHz for Class B equipment			
Frequency (MHz)	Measurement		Class B limits dB(uV/m)
	Distance (m)	Detector type/ bandwidth	OATS/SAC
30 to 230	10	Quasi Peak / 120 kHz	30
230 to 1000			37
30 to 230	3		40
230 to 1000			47

Requirements for radiated emissions at frequencies above 1 GHz for Class B equipment			
Frequency (MHz)	Measurement		Class B limits dB(uV/m)
	Distance (m)	Detector type/ bandwidth	FSOATS
1000 to 3000	3	Average / 1 MHz	50
3000 to 6000			64
1000 to 3000		Peak / 1 MHz	70
3000 to 6000			74

- Note:**
1. The lower limit shall apply at the transition frequency.
 2. Detector function in the form: PK = Peak, QP = Quasi Peak, AV = Average
 3. The test result calculated as following:
 Measurement Value = Reading Level + Correct Factor
 Correction Factor = Antenna factor + Cable loss (Antenna to preamplifier) - preamplifier Gain
 + Cable loss (preamplifier to receiver)
 Margin Level = Measurement Value - Limit Value



4.3.2 Test Instrument

Item	Equipment	Manufacturer	Model	Meter No.	Calibration Date
1	Horn Antenna	Schwarzbeck	BBHA 9120 D	CT-1-001	Apr. 01, 2016
2	Bilog Antenna	Schwarzbeck	VULB 9168	CT-1-002-1	Mar. 30, 2016
3	Test Cable	HARUIN	CFD400NL-LW	CT-1-070	Aug. 02, 2016
4	Preamplifier	EM Electronics Corporation	EM30265	CT-1-013	Aug. 02, 2016
5	Test Cable	HARBOUR	27478 LL142	CT-1-073	Aug. 03, 2016
6	EMI Test Receiver	Agilent	N9038A	CT-1-068	Aug. 02, 2016
7	Measurement Software	Ez-EMC	Ver : FA-03A2 RE	CT-3-012	No calibration request

Note: 1. The calibration interval of the above test instruments is 12 months.

4.3.3 Test Procedure

- a. The EUT was placed on the top of a turntable 0.8 meters above the ground at a 3 m or 10 m open area test site. The table was rotated 360 degrees to determine the position of the high radiation emissions.
- b. The height of the test antenna shall vary between 1 m to 4 m. Both vertical and horizontal polarizations of the antenna were set to make the measurement.
- c. The EUT was set up as per the test configuration to simulate typical usage per the user's manual. All I/O cables were positioned to simulate typical usage. The actual test configuration, please refer to EUT test photos.
- d. The initial step in collecting radiated emission data is a Spectrum Mode scanning the measurement frequency range.

Blow 1GHz:

Reading in which marked as QP or Peak means measurements by using Spectrum Mode with detector RBW=120kHz.

If the Spectrum Mode measured peak value compliance with and lower than Quasi Peak Limit, the EUT shall be deemed to meet QP Limits.

Above 1GHz:

Reading in which marked as Peak & AVG means measurements by using Spectrum Mode with setting in RBW=1MHz.

If the Spectrum Mode measured value compliance with the Peak Limits and lower than AVG Limits, the EUT shall be deemed to meet both Peak and AVG Limits.

- e. Emission frequency and amplitude were recorded, recording at least six highest emissions. The EUT and cable configuration of the above highest emission levels were recorded. The test data of the worst case was recorded.

4.3.4 Deviation from Test Standard

No deviation

4.3.5 Test Setup

Standard: EN 55022 & EN 55032

< Radiated Emissions Frequency: 30 MHz to 1000 MHz >

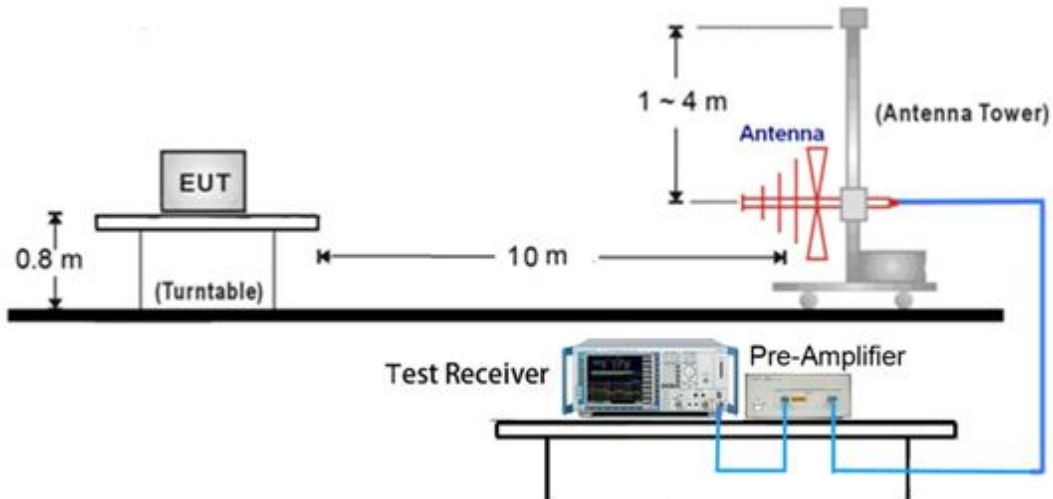

< Radiated Emissions Frequency: above 1GHz >

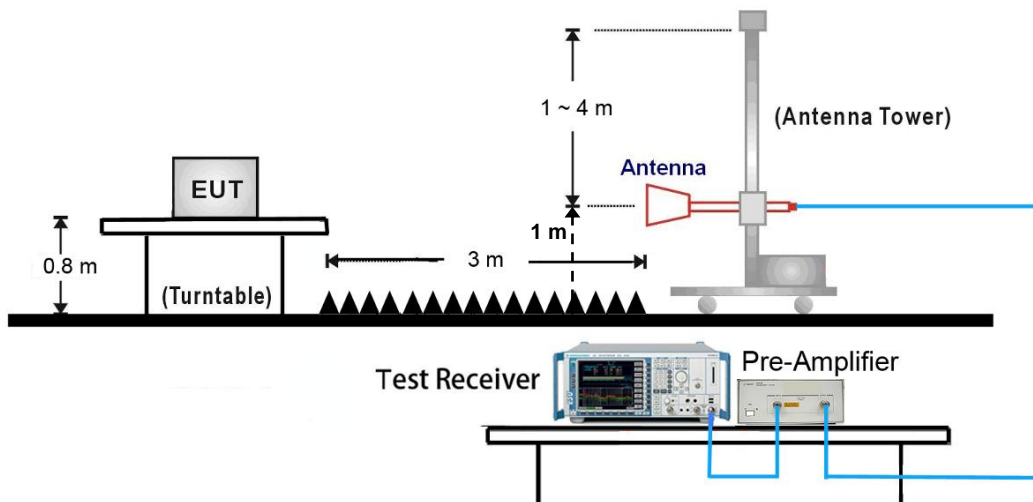

Note:

- (1) Please refer to the 4.3.7 for the actual test configuration.
- (2) The formula of measured value as: $\text{Test Result} = \text{Reading} + \text{Correction Factor}$
- (3) Detector function in the form: PK = Peak, QP = Quasi Peak, AV = Average
- (4) The test result calculated as following:
 $\text{Measurement Value} = \text{Reading Level} + \text{Correct Factor}$
 $\text{Correct Factor} = \text{Antenna Factor} + \text{Cable Loss} - \text{Amplifier Gain (if use)}$
 $\text{Margin Level} = \text{Measurement Value} - \text{Limit Value}$

Standard: EN 55032

< EUT placement top view and measurement distance >

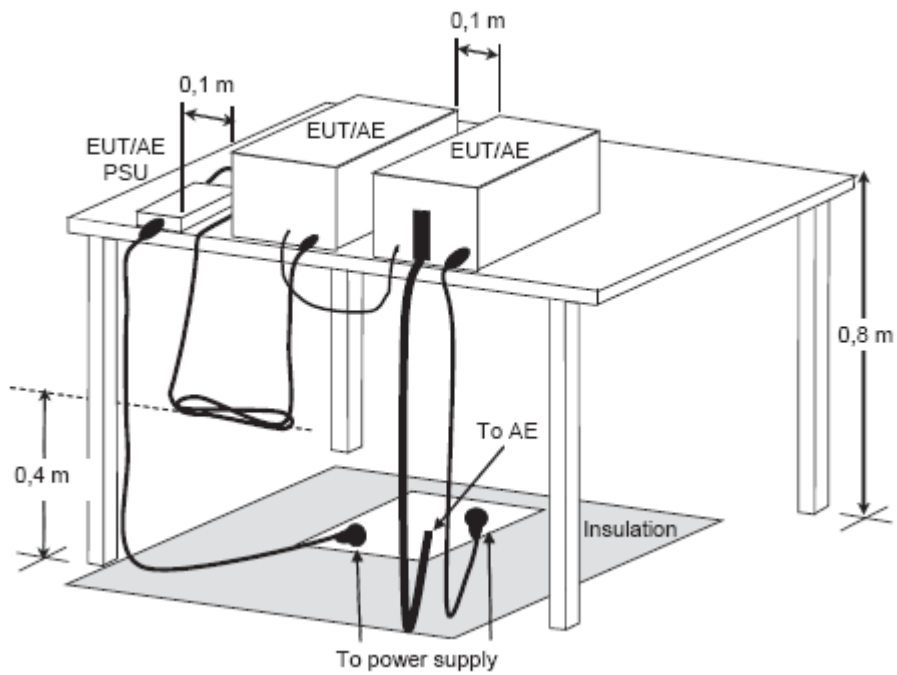
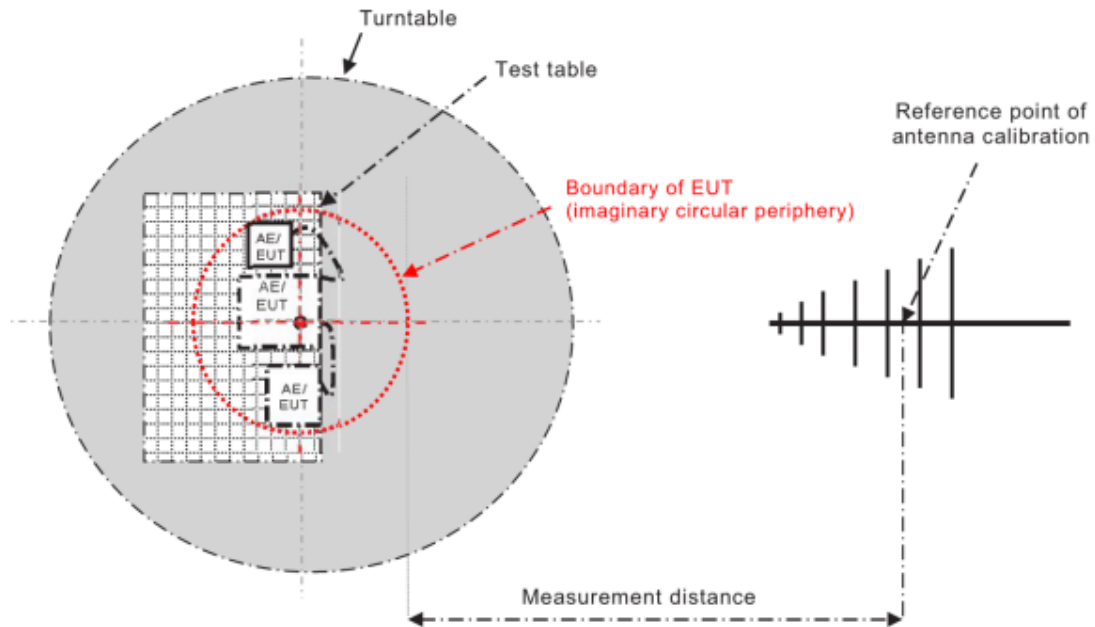



4.3.6 Test Result

Test Voltage	48Vdc (from POE)	Frequency Range	30 – 1000 MHz
Environmental Conditions	22°C, 63% RH	6dB Bandwidth	120 kHz
Test Date	2016/11/01	Test Distance	10m
Tested by	Evan Cheng	Polarization	Vertical
Test mode	A		

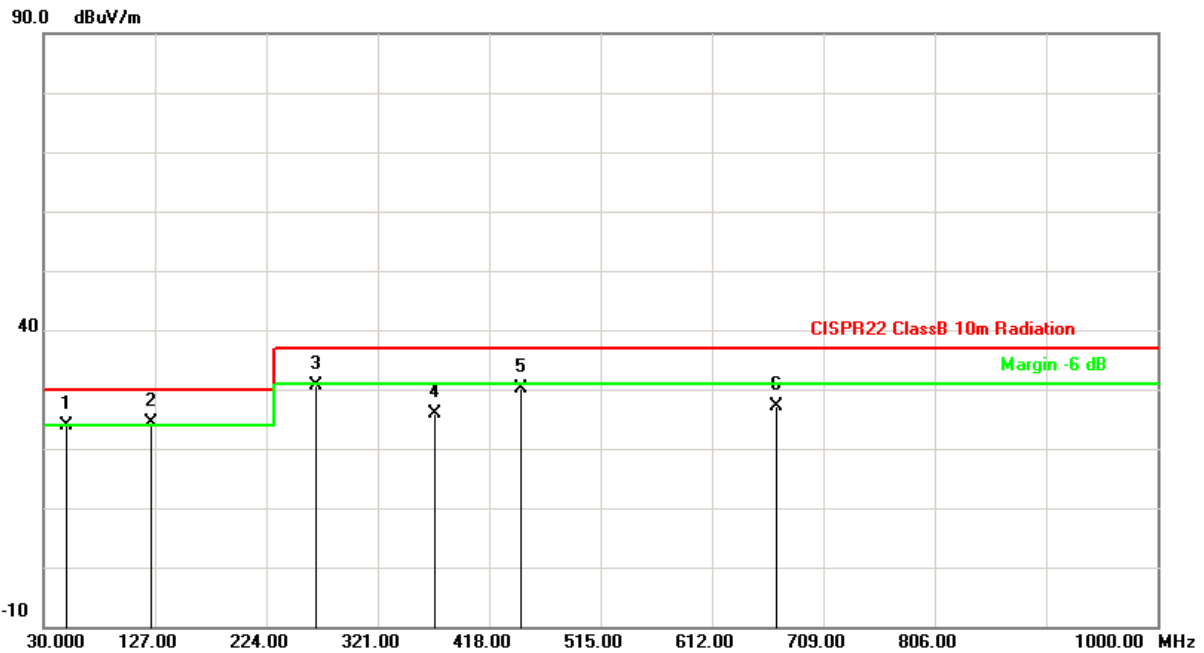

No.	Frequency (MHz)	Reading Level (dBuV)	Correct Factor (dB/m)	Measurement (dBuV/m)	Limit (dBuV/m)	Margin (dB)	Detector	Antenna Height (cm)	Table Degree (degree)
1	50.4160	41.91	-17.93	23.98	30.00	-6.02	QP	100	360
2	124.1900	45.21	-20.93	24.28	30.00	-5.72	QP	100	125
3	267.0000	52.42	-21.75	30.67	37.00	-6.33	QP	100	151
4	371.2600	44.67	-18.84	25.83	37.00	-11.17	QP	100	261
5	445.5150	46.87	-16.65	30.22	37.00	-6.78	QP	100	62
6	668.2600	39.00	-11.89	27.11	37.00	-9.89	QP	100	98

Remark: 1. QP = Quasi Peak
 2. Correction Factor = Antenna factor + Cable loss (Antenna to preamplifier) - preamplifier Gain + Cable loss (preamplifier to receiver)
 3. Measurement Value = Reading Level + Correct Factor
 4. Margin Level = Measurement Value - Limit Value



Test Voltage	48Vdc (from POE)	Frequency Range	30 – 1000 MHz
Environmental Conditions	22°C, 63% RH	6dB Bandwidth	120 kHz
Test Date	2016/11/01	Test Distance	10m
Tested by	Evan Cheng	Polarization	Horizontal
Test mode	A		

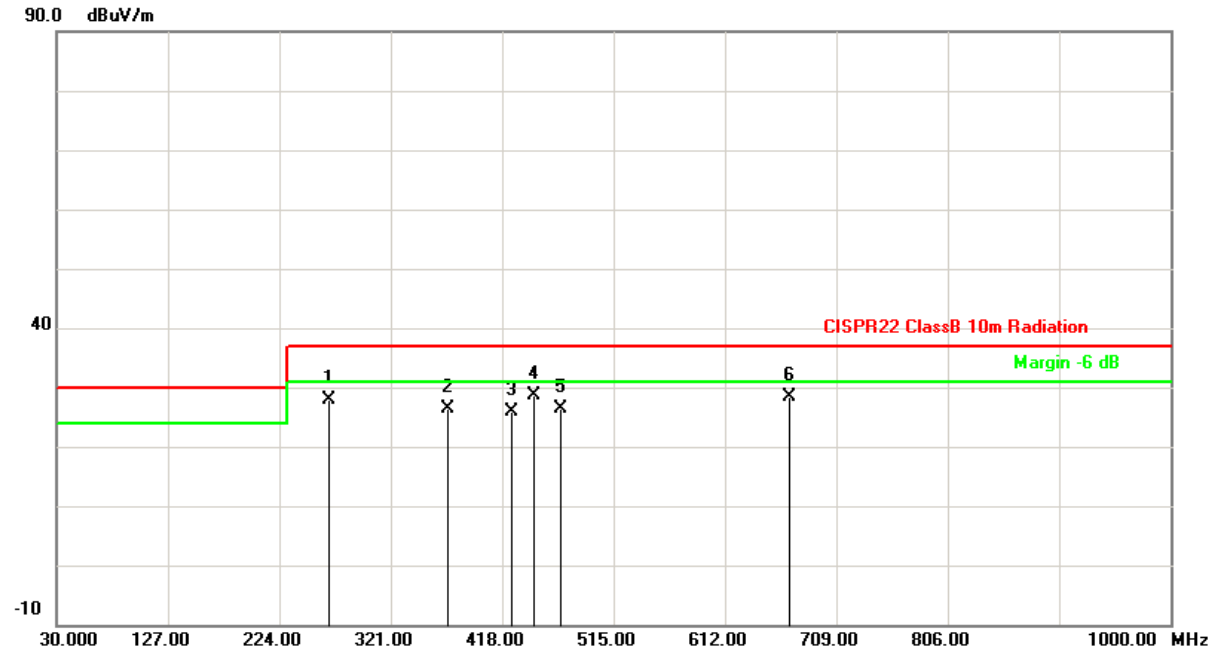

No.	Frequency (MHz)	Reading Level (dBuV)	Correct Factor (dB/m)	Measurement (dBuV/m)	Limit (dBuV/m)	Margin (dB)	Detector	Antenna Height (cm)	Table Degree (degree)
1	267.0000	49.61	-21.75	27.86	37.00	-9.14	QP	400	129
2	371.2515	45.31	-18.84	26.47	37.00	-10.53	QP	346	161
3	427.0000	43.24	-17.24	26.00	37.00	-11.00	QP	189	52
4	445.5100	45.25	-16.65	28.60	37.00	-8.40	QP	187	57
5	469.0000	42.37	-16.05	26.32	37.00	-10.68	QP	186	54
6	668.2550	40.30	-11.89	28.41	37.00	-8.59	QP	187	50

Remark:

1. QP = Quasi Peak
2. Correction Factor = Antenna factor + Cable loss (Antenna to preamplifier) - preamplifier Gain + Cable loss (preamplifier to receiver)
3. Measurement Value = Reading Level + Correct Factor
4. Margin Level = Measurement Value - Limit Value



Test Voltage	48Vdc (from POE)	Frequency Range	30 – 1000 MHz
Environmental Conditions	26°C, 60% RH	6dB Bandwidth	120 kHz
Test Date	2017/01/06	Test Distance	10m
Tested by	Evan Cheng	Polarization	Vertical
Test mode	B		

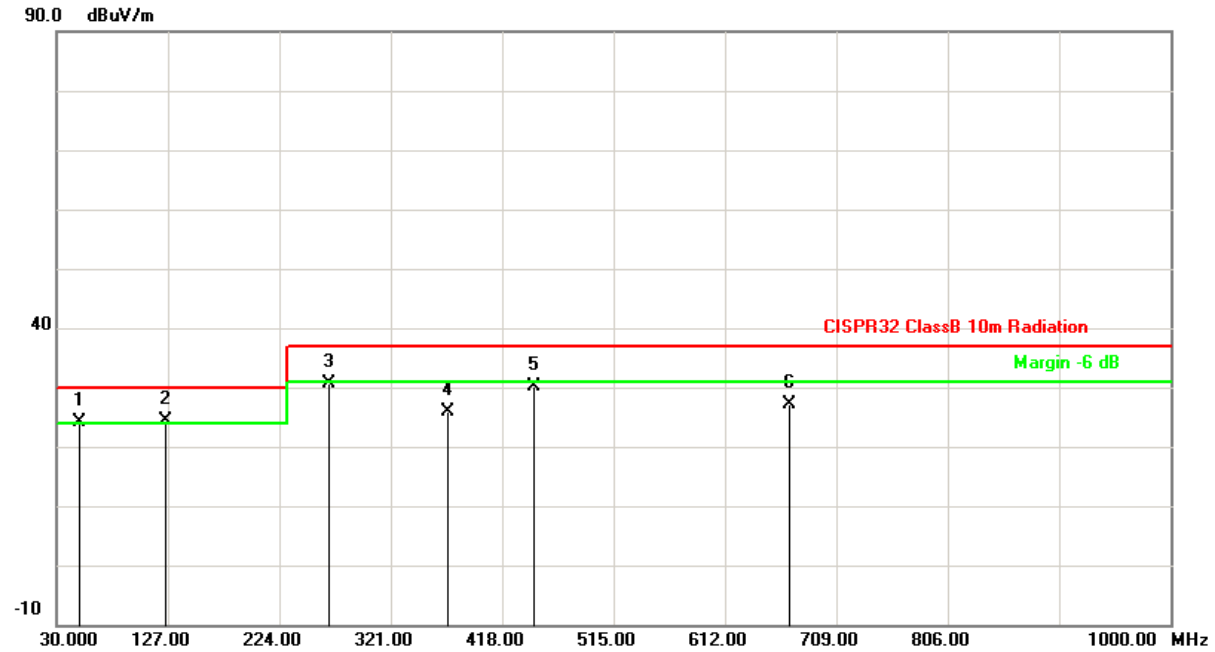

No.	Frequency (MHz)	Reading Level (dBuV)	Correct Factor (dB/m)	Measurement (dBuV/m)	Limit (dBuV/m)	Margin (dB)	Detector	Antenna Height (cm)	Table Degree (degree)
1	50.4000	41.95	-17.93	24.02	30.00	-5.98	QP	100	355
2	125.1000	45.24	-20.88	24.36	30.00	-5.64	QP	100	126
3	267.0000	52.49	-21.75	30.74	37.00	-6.26	QP	100	150
4	371.2000	44.61	-18.84	25.77	37.00	-11.23	QP	100	265
5	445.5000	46.82	-16.65	30.17	37.00	-6.83	QP	100	63
6	668.2000	39.06	-11.90	27.16	37.00	-9.84	QP	100	91

Remark: 1. QP = Quasi Peak
 2. Correction Factor = Antenna factor + Cable loss (Antenna to preamplifier) - preamplifier Gain + Cable loss (preamplifier to receiver)
 3. Measurement Value = Reading Level + Correct Factor
 4. Margin Level = Measurement Value - Limit Value



Test Voltage	48Vdc (from POE)	Frequency Range	30 – 1000 MHz
Environmental Conditions	26°C, 60% RH	6dB Bandwidth	120 kHz
Test Date	2017/01/06	Test Distance	10m
Tested by	Evan Cheng	Polarization	Horizontal
Test mode	B		

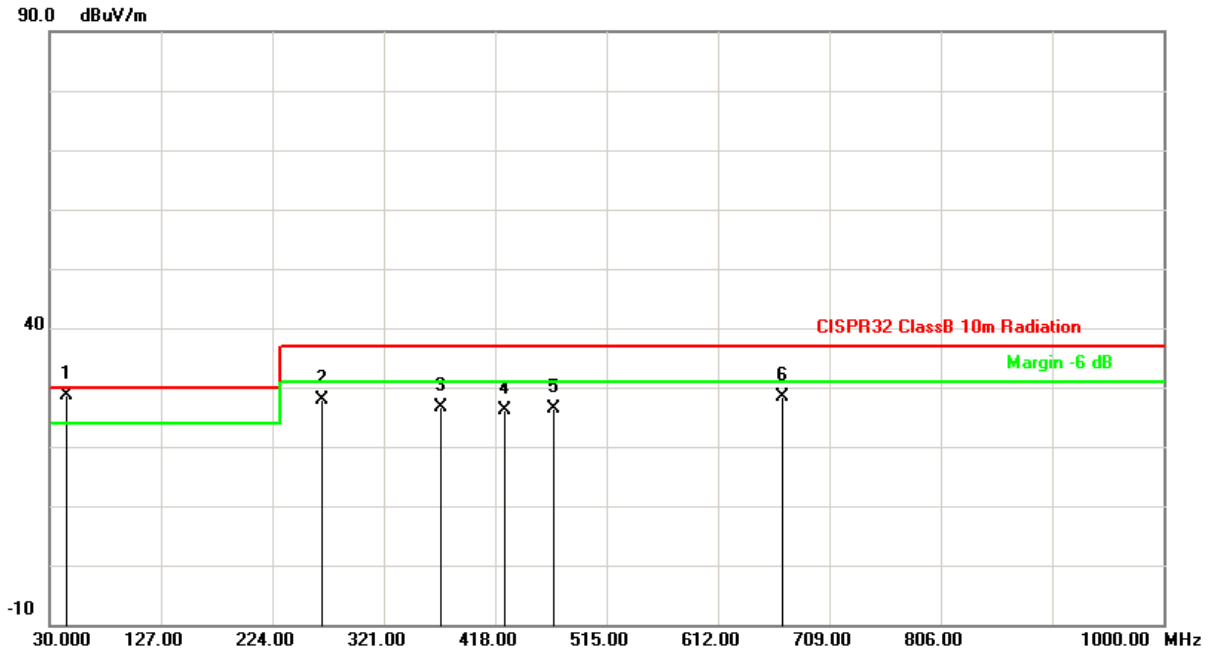

No.	Frequency (MHz)	Reading Level (dBuV)	Correct Factor (dB/m)	Measurement (dBuV/m)	Limit (dBuV/m)	Margin (dB)	Detector	Antenna Height (cm)	Table Degree (degree)
1	44.5000	46.18	-17.56	28.62	30.00	-1.38	QP	175	62
2	267.0000	49.65	-21.75	27.90	37.00	-9.10	QP	400	133
3	371.2000	45.36	-18.84	26.52	37.00	-10.48	QP	400	160
4	427.0000	43.29	-17.24	26.05	37.00	-10.95	QP	190	50
5	469.0000	42.33	-16.05	26.28	37.00	-10.72	QP	180	65
6	668.2000	40.40	-11.90	28.50	37.00	-8.50	QP	185	55

Remark:

1. QP = Quasi Peak
2. Correction Factor = Antenna factor + Cable loss (Antenna to preamplifier) - preamplifier Gain + Cable loss (preamplifier to receiver)
3. Measurement Value = Reading Level + Correct Factor
4. Margin Level = Measurement Value - Limit Value



Test Voltage	48Vdc (from POE)	Frequency Range	1 – 6GHz
Environmental Conditions	22°C, 63% RH	6dB Bandwidth	1MHz
Test Date	2016/11/01	Test Distance	3m
Tested by	Evan Cheng	Polarization	Vertical
Test mode	A		

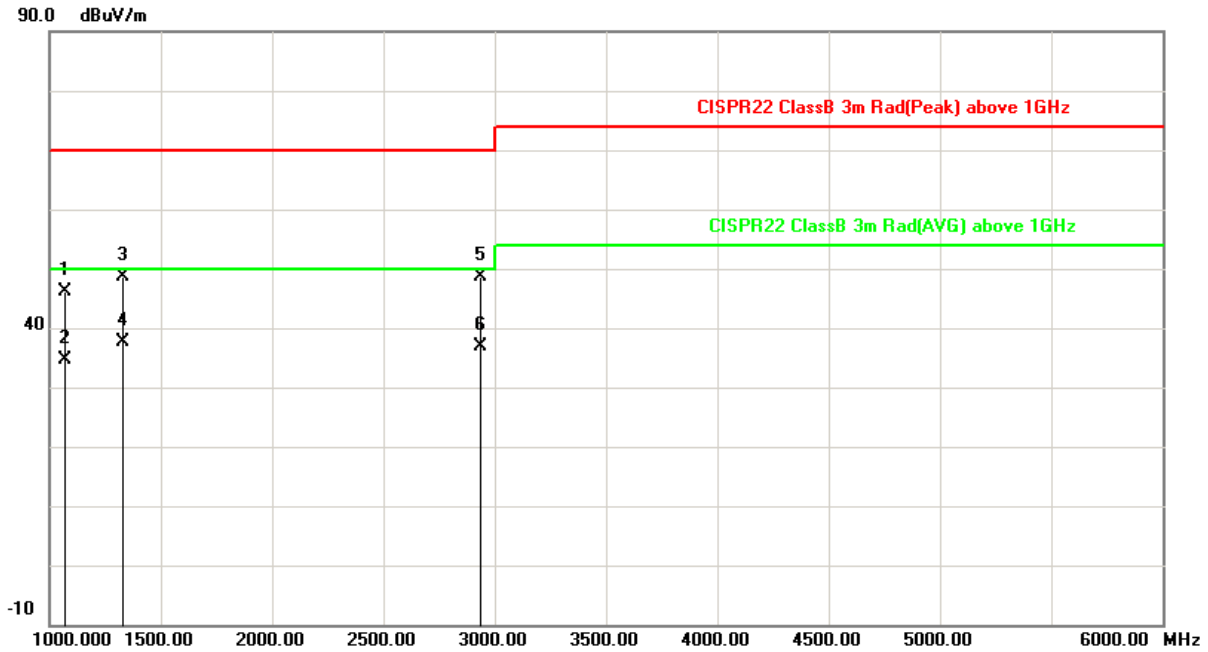

No.	Frequency (MHz)	Reading Level (dBuV)	Correct Factor (dB/m)	Measurement (dBuV/m)	Limit (dBuV/m)	Margin (dB)	Detector	Antenna Height (cm)	Table Degree (degree)
1	1067.000	59.41	-13.36	46.05	70.00	-23.95	peak	100	284
2	1067.000	47.88	-13.36	34.52	50.00	-15.48	AVG	100	284
3	1332.000	59.61	-10.97	48.64	70.00	-21.36	peak	100	276
4	1332.000	48.72	-10.97	37.75	50.00	-12.25	AVG	100	276
5	2937.000	51.62	-2.94	48.68	70.00	-21.32	peak	100	254
6	2937.000	39.77	-2.94	36.83	50.00	-13.17	AVG	100	254

Remark: 1. peak = Peak, AVG = Average
 2. Correction Factor = Antenna factor + Cable loss (Antenna to preamplifier) - preamplifier Gain + Cable loss (preamplifier to receiver)
 3. Measurement Value = Reading Level + Correct Factor
 4. Margin Level = Measurement Value - Limit Value



Test Voltage	48Vdc (from POE)	Frequency Range	1 – 6GHz
Environmental Conditions	22°C, 63% RH	6dB Bandwidth	1MHz
Test Date	2016/11/01	Test Distance	3m
Tested by	Evan Cheng	Polarization	Horizontal
Test mode	A		

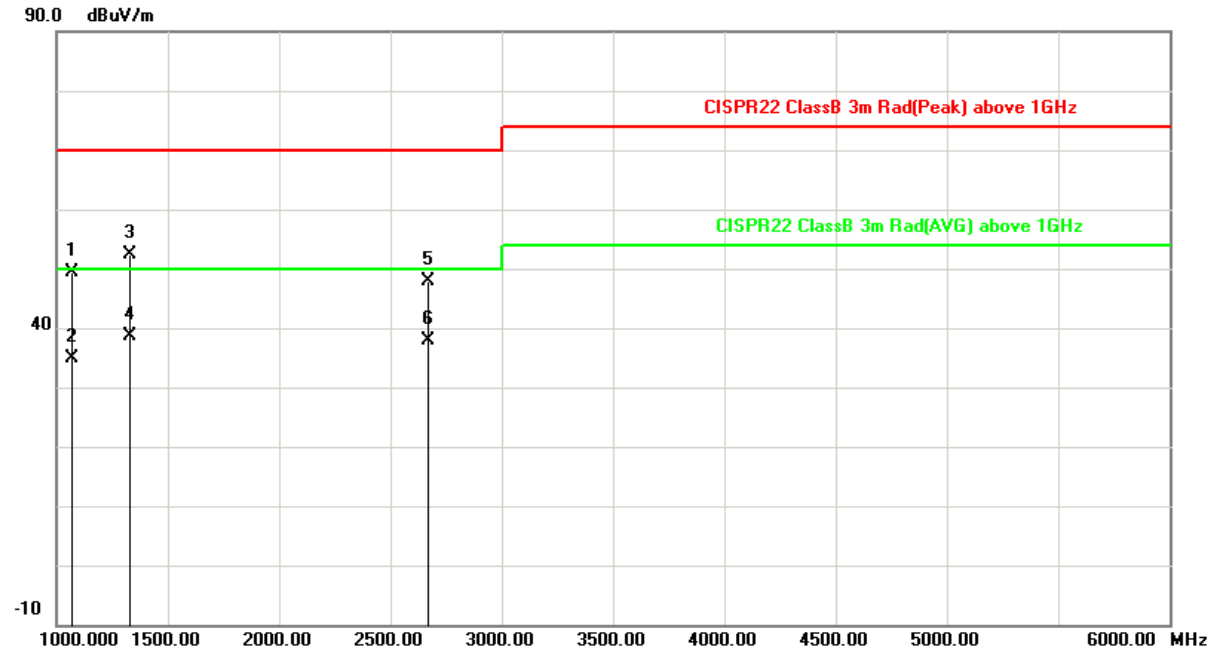

No.	Frequency (MHz)	Reading Level (dBuV)	Correct Factor (dB/m)	Measurement (dBuV/m)	Limit (dBuV/m)	Margin (dB)	Detector	Antenna Height (cm)	Table Degree (degree)
1	1067.000	62.84	-13.36	49.48	70.00	-20.52	peak	100	257
2	1067.000	48.32	-13.36	34.96	50.00	-15.04	AVG	100	257
3	1333.000	63.44	-10.96	52.48	70.00	-17.52	peak	100	341
4	1333.000	49.65	-10.96	38.69	50.00	-11.31	AVG	100	341
5	2667.000	52.12	-4.27	47.85	70.00	-22.15	peak	100	256
6	2667.000	42.12	-4.27	37.85	50.00	-12.15	AVG	100	256

Remark: 1. peak = Peak, AVG = Average
 2. Correction Factor = Antenna factor + Cable loss (Antenna to preamplifier) - preamplifier Gain + Cable loss (preamplifier to receiver)
 3. Measurement Value = Reading Level + Correct Factor
 4. Margin Level = Measurement Value - Limit Value



Test Voltage	48Vdc (from POE)	Frequency Range	1 – 6GHz
Environmental Conditions	25°C, 59% RH	6dB Bandwidth	1MHz
Test Date	2017/01/06	Test Distance	3m
Tested by	Evan Cheng	Polarization	Vertical
Test mode	B		

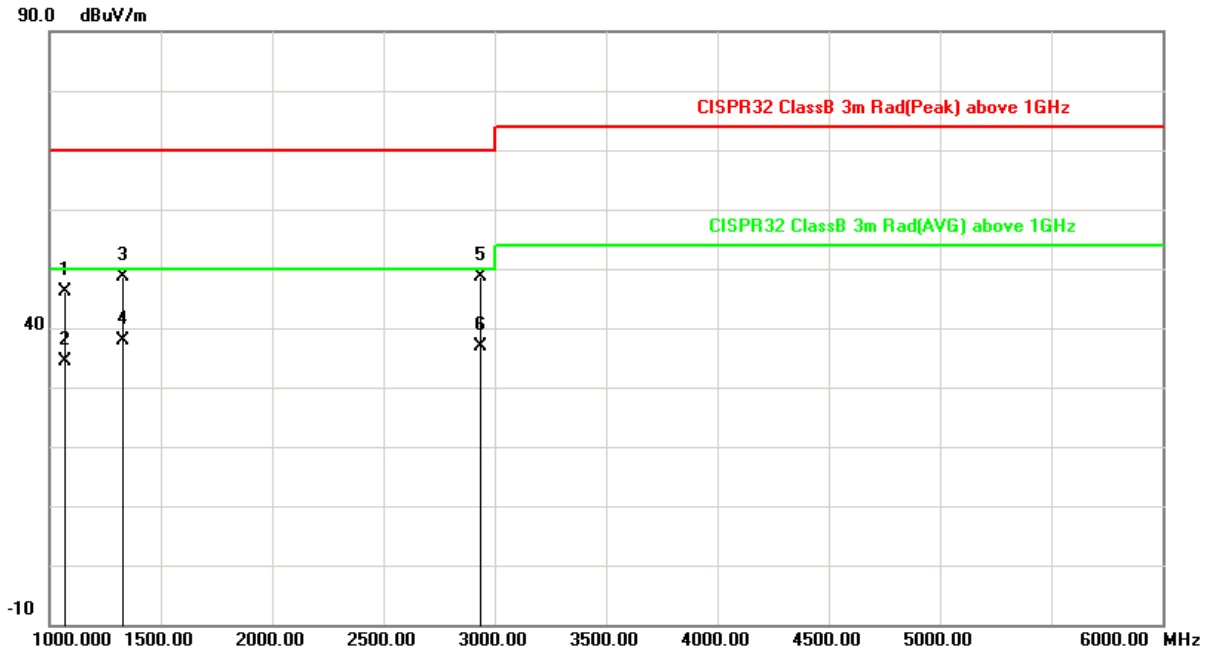

No.	Frequency (MHz)	Reading Level (dBuV)	Correct Factor (dB/m)	Measurement (dBuV/m)	Limit (dBuV/m)	Margin (dB)	Detector	Antenna Height (cm)	Table Degree (degree)
1	1067.000	59.44	-13.36	46.08	70.00	-23.92	peak	100	289
2	1067.000	47.82	-13.36	34.46	50.00	-15.54	AVG	100	289
3	1332.000	59.69	-10.97	48.72	70.00	-21.28	peak	100	270
4	1332.000	48.77	-10.97	37.80	50.00	-12.20	AVG	100	270
5	2937.000	51.69	-2.94	48.75	70.00	-21.25	peak	100	259
6	2937.000	39.71	-2.94	36.77	50.00	-13.23	AVG	100	259

Remark: 1. peak = Peak, AVG = Average
 2. Correction Factor = Antenna factor + Cable loss (Antenna to preamplifier) - preamplifier Gain + Cable loss (preamplifier to receiver)
 3. Measurement Value = Reading Level + Correct Factor
 4. Margin Level = Measurement Value - Limit Value



Test Voltage	48Vdc (from POE)	Frequency Range	1 – 6GHz
Environmental Conditions	25°C, 59% RH	6dB Bandwidth	1MHz
Test Date	2017/01/06	Test Distance	3m
Tested by	Evan Cheng	Polarization	Horizontal
Test mode	B		

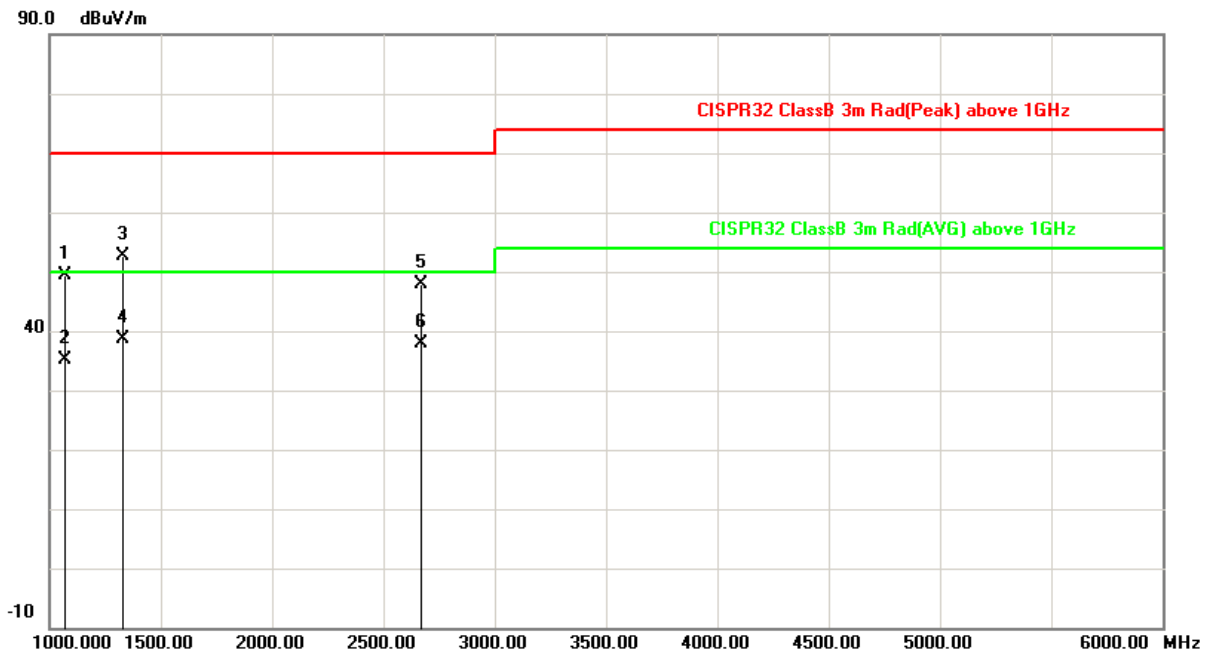

No.	Frequency (MHz)	Reading Level (dBuV)	Correct Factor (dB/m)	Measurement (dBuV/m)	Limit (dBuV/m)	Margin (dB)	Detector	Antenna Height (cm)	Table Degree (degree)
1	1067.000	62.81	-13.36	49.45	70.00	-20.55	peak	100	251
2	1067.000	48.39	-13.36	35.03	50.00	-14.97	AVG	100	251
3	1333.000	63.49	-10.96	52.53	70.00	-17.47	peak	100	345
4	1333.000	49.61	-10.96	38.65	50.00	-11.35	AVG	100	345
5	2667.000	52.19	-4.27	47.92	70.00	-22.08	peak	100	260
6	2667.000	42.15	-4.27	37.88	50.00	-12.12	AVG	100	260

Remark: 1. peak = Peak, AVG = Average
 2. Correction Factor = Antenna factor + Cable loss (Antenna to preamplifier) - preamplifier Gain + Cable loss (preamplifier to receiver)
 3. Measurement Value = Reading Level + Correct Factor
 4. Margin Level = Measurement Value - Limit Value

4.3.7 Photographs of Test Configuration

Radiated Emission Test (30MHz~1GHz) Test mode A

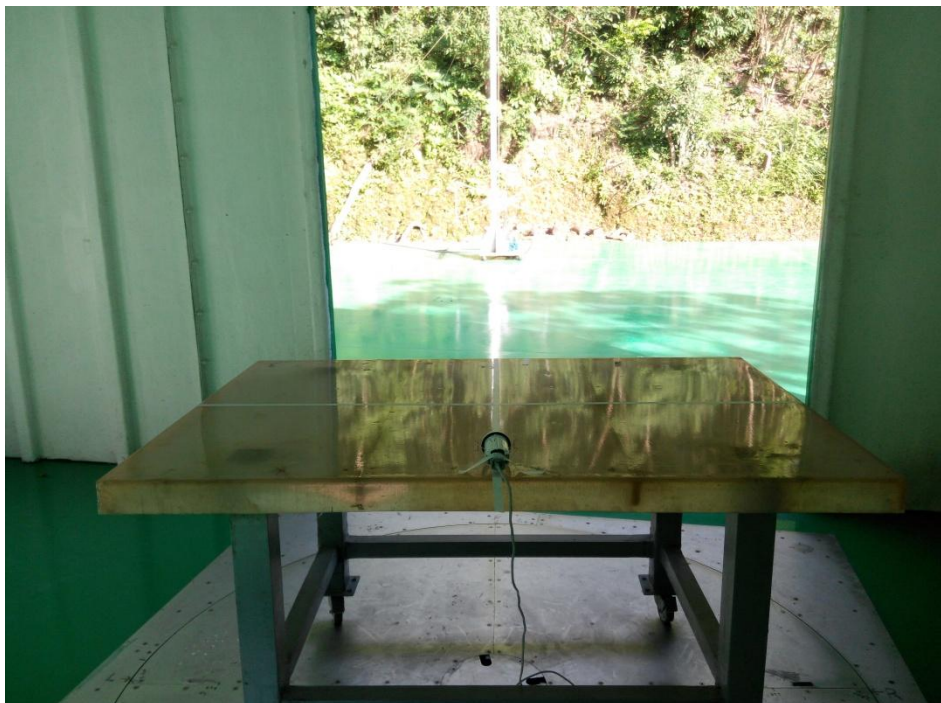

Test mode B



Radiated Emission Test (Above 1GHz)
Test mode A

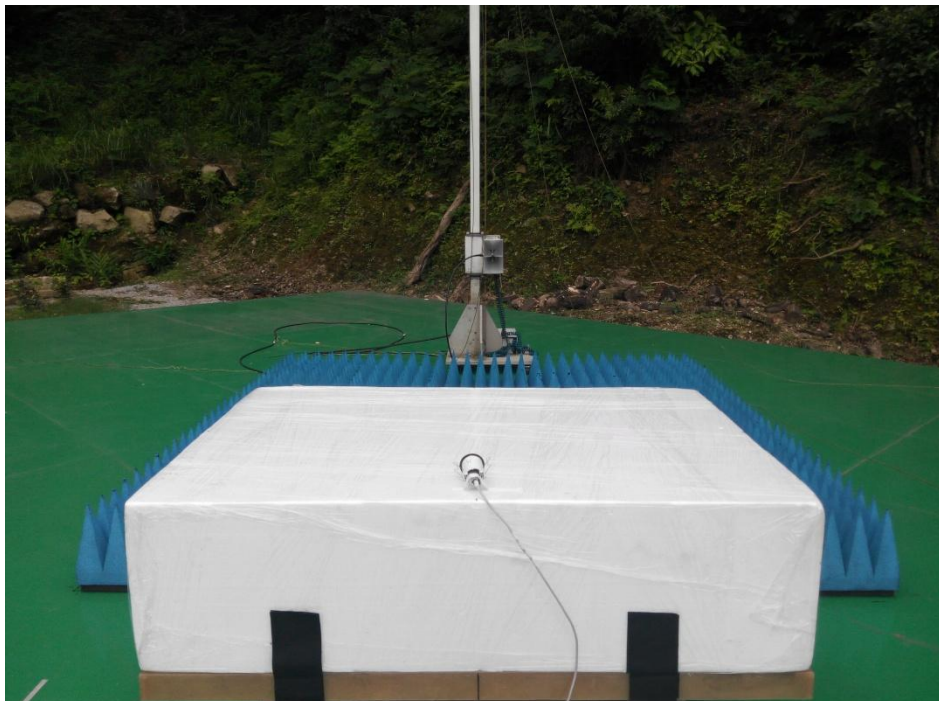
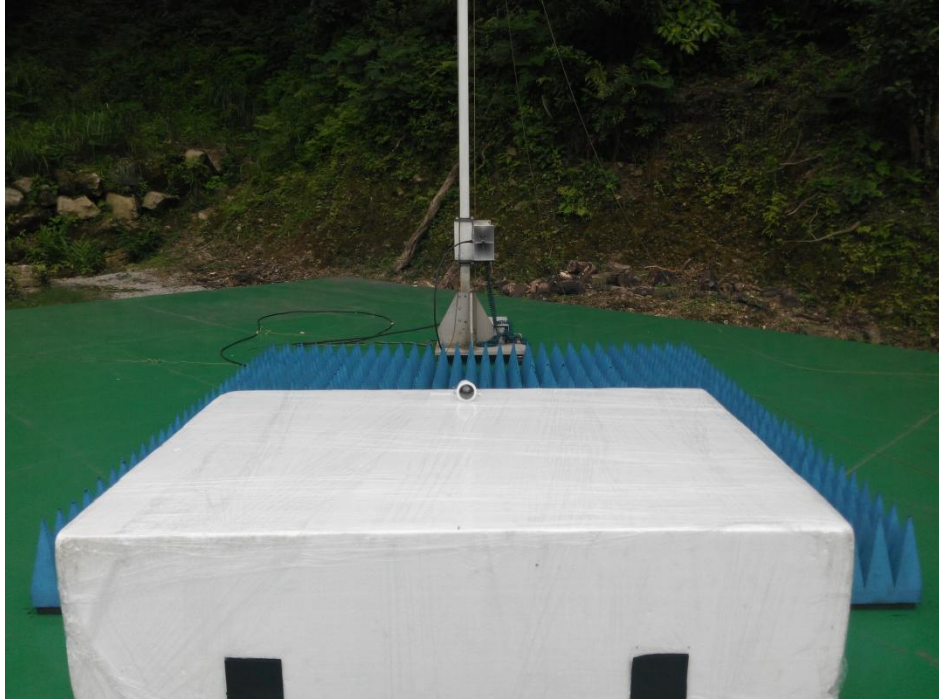

Test mode B

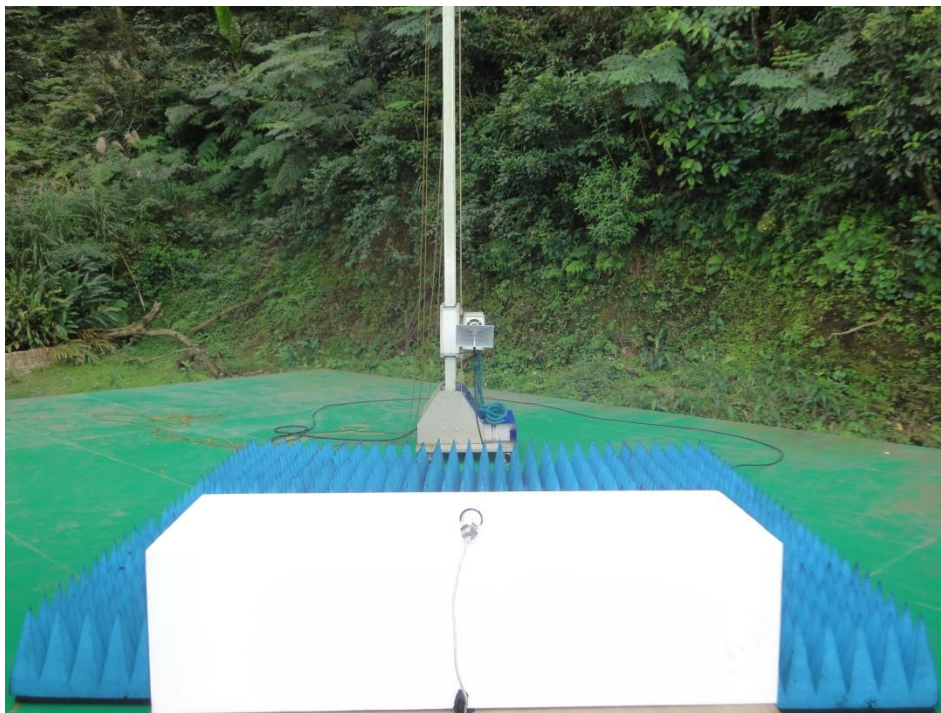
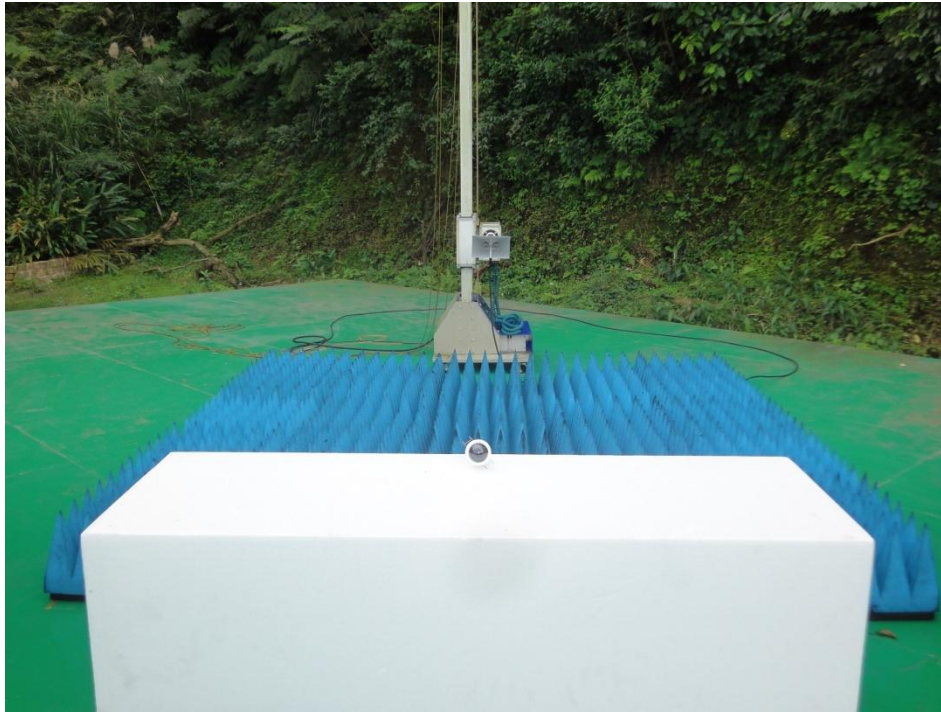



4.4 Harmonics Current Measurement

The test is determined no necessary for the EUT do not operate from the power lines or contain provisions for operation while connected to the power lines.



4.5 Voltage Fluctuation and Flicker Measurement

The test is determined no necessary for the EUT do not operate from the power lines or contain provisions for operation while connected to the power lines.

5.2 Performance Criteria

According to Clause 7 of EN 55024 standard, the general performance criteria as following:

Criteria A	The equipment shall continue to operate as intended without operator intervention. No degradation of performance or loss of function is allowed below a performance level specified by the manufacturer when the equipment is used as intended. The performance level may be replaced by a permissible loss of performance. If the minimum performance level or the permissible performance loss is not specified by the manufacturer, then either of these may be derived from the product description and documentation, and by what the user may reasonably expect from the equipment if used as intended.
Criteria B	After the test, the equipment shall continue to operate as intended without operator intervention. No degradation of performance or loss of function is allowed, after the application of the phenomenon below a performance level specified by the manufacturer, when the equipment is used as intended. The performance level may be replaced by a permissible loss of performance. During the test, degradation of performance is allowed. However, no change of operating state if stored data is allowed to persist after the test. If the minimum performance level (or the permissible performance loss) is not specified by the manufacturer, then either of these may be derived from the product description and documentation, and by what the user may reasonably expect from the equipment if used as intended.
Criteria C	Loss of function is allowed, provided the function is self-recoverable, or can be restored by the operation of the controls by the user in accordance with the manufacturer's instructions. Functions, and/or information stored in non-volatile memory, or protected by a battery backup, shall not be lost.

5.3 Electrostatic Discharge (ESD)

5.3.1 Test Specification

Standard	IEC/EN 61000-4-2
Discharge Impedance	330 ohm / 150 pF
Discharge Voltage	Air Discharge: $\pm 2, \pm 4, \pm 8$ kV (Direct) Contact Discharge: ± 4 kV (Direct/Indirect)
Number of Discharge	Air: Minimum 10 times at each point. Contact: Minimum 25 times at each point and minimum 200 times in total
Discharge Mode	Single Discharge
Discharge Period	1 second minimum

5.3.2 Test Instrument

Item	Equipment	Manufacturer	Model	Meter No.	Calibration Date
1	ESD Simulator/ Discharge Gun	NoiseKen	ESS-B3011	CT-1-089	Aug. 06, 2016
2	Digital Thermo-Hygro Meter	N/A	HTC-8	CT-2-047	Mar. 29, 2016
3	Atmosphere pressure meter	N/A	Kat.Nr.45.10 00.01	CT-2-052-1	Aug. 01, 2016

Note: 1. The calibration interval of the above test instruments is 12 months.

5.3.3 Test Procedure

The test generator necessary to perform direct and indirect application of discharge to the EUT in following methods:

a. Contact discharges to the conductive surface and coupling planes:

The EUT shall be exposed to at least 200 discharges, 100 each at positive and negative polarity, at a minimum of four test points. One of the test points shall be subjected to at least 50 indirect discharges to the center of the front edge of the horizontal coupling plane (HCP). The remaining three test points shall be each receives at least 50 direct contact discharges. If no direct contact test points are available, shall be at least 200 indirect discharges applied in the indirect mode. Test shall be performed at a maximum repetition rate of one discharge per second.

Vertical Coupling Plane (VCP):

The coupling plane, of dimensions 0.5 m × 0.5 m, is placed parallel to, and positioned at a distance 0.1 m from, the EUT, with the discharge electrode touching the coupling plane. The four faces of the EUT will be performed with electrostatic discharge.

Horizontal Coupling Plane (HCP):

The coupling plane, of dimensions 1.6 m × 0.8 m, is placed under the EUT. The generator shall be positioned vertically a distance of 0.1 m from the EUT, with the discharge electrode touching the coupling plane. The four faces of the EUT will be performed with electrostatic discharge.

b. Air discharge at apertures and slots and insulating surface:

On those parts of the EUT where it is not possible to perform contact discharge testing, the equipment should be investigated to identify user accessible points where breakdown may occur. Such points are tested using the air discharge method. This investigation should be restricted to those area normally handled by the user. A minimum 10 single air discharges shall be applied to the selected test point for each such area.

5.3.4 Deviation from Test Standard

No deviation

5.3.5 Test Setup

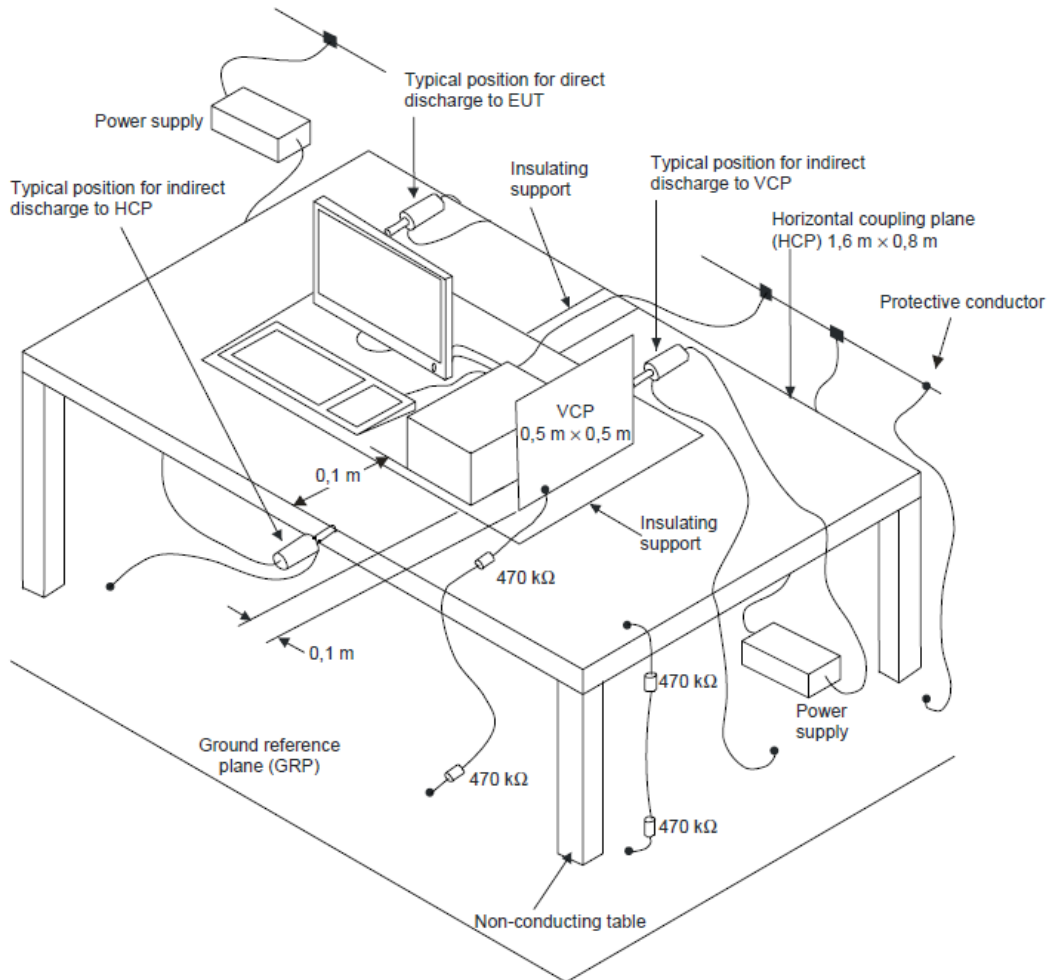



5.3.6 Test Result

Test Voltage	48Vdc (from POE)	Test Date	2016/11/02
Environmental Conditions	22°C, 50% RH	Pressure	1019 mbar
Tested by	Eddy Tsai		

Test Results of Direct Application

Air Discharge				
Test Point	Discharge Level (kV)			Result
	±2	±4	±8	
Front	A	A	A	A
Left	A	A	A	A
Right	A	A	A	A
Top	A	A	A	A
Bottom	A	A	A	A

* Test location(s) in which discharge to be applied illustrated by photos shown in next page(s).

Contact Discharge				
Test Point	Discharge Level (kV)			Result
	±4			
Back	B (#1)			B
Left	B (#1)			B
Right	B (#1)			B
Top	A			A

* Test location(s) in which discharge to be applied illustrated by photos shown in next page(s).

Test Results of Indirect Application

HCP Discharge				
Test Point	Discharge Level (kV)			Result
	±4			
Front	A			A
Back	A			A
Left	A			A
Right	A			A

VCP Discharge				
Test Point	Discharge Level (kV)			Result
	±4			
Front	A			A
Back	A			A
Left	A			A
Right	A			A

Note:

Criteria A: The EUT function was correct during the test.

Criteria B: (#1) The LAN was interrupted and video disappeared during the test, but could self-recover to the initial operation after the test.

Description of Test Points

Front

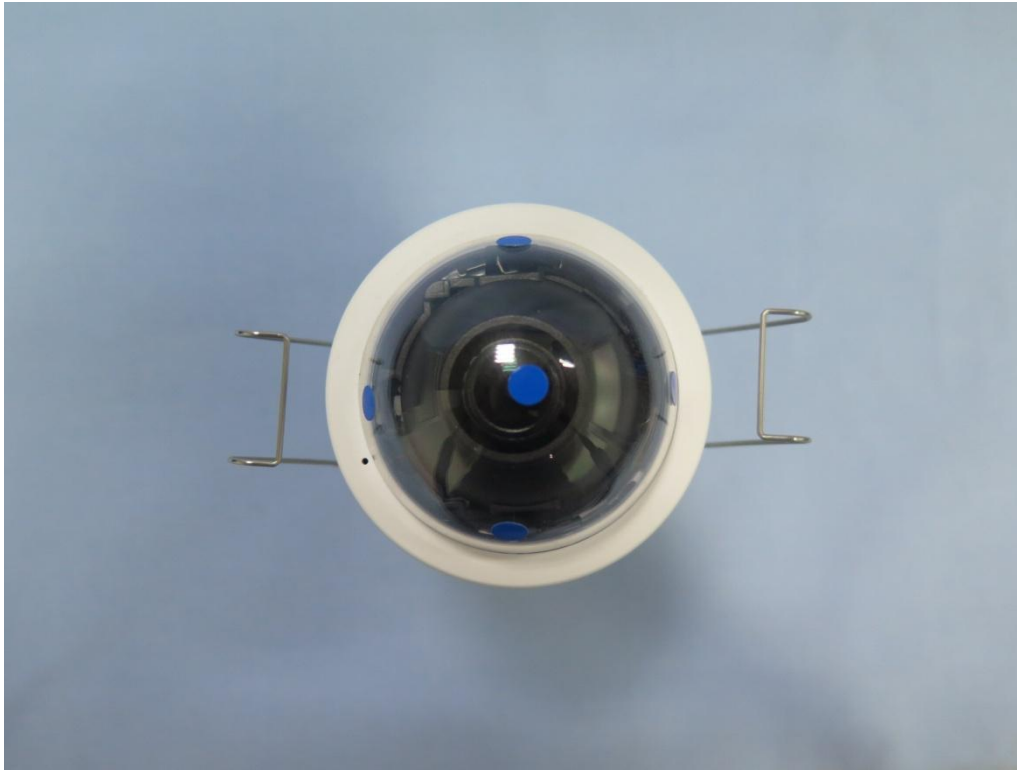

Back

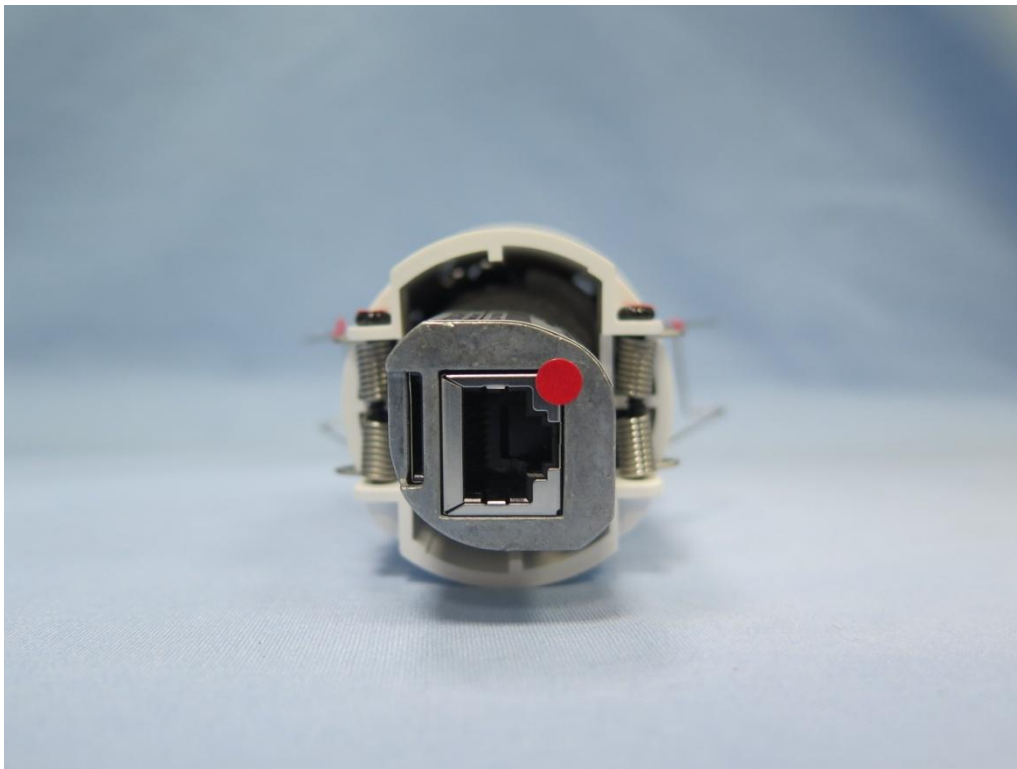

*Red Dot - Contact Discharged
Blue Dot - Air Discharged

Left



Right



*Red Dot - Contact Discharged
Blue Dot - Air Discharged

Top

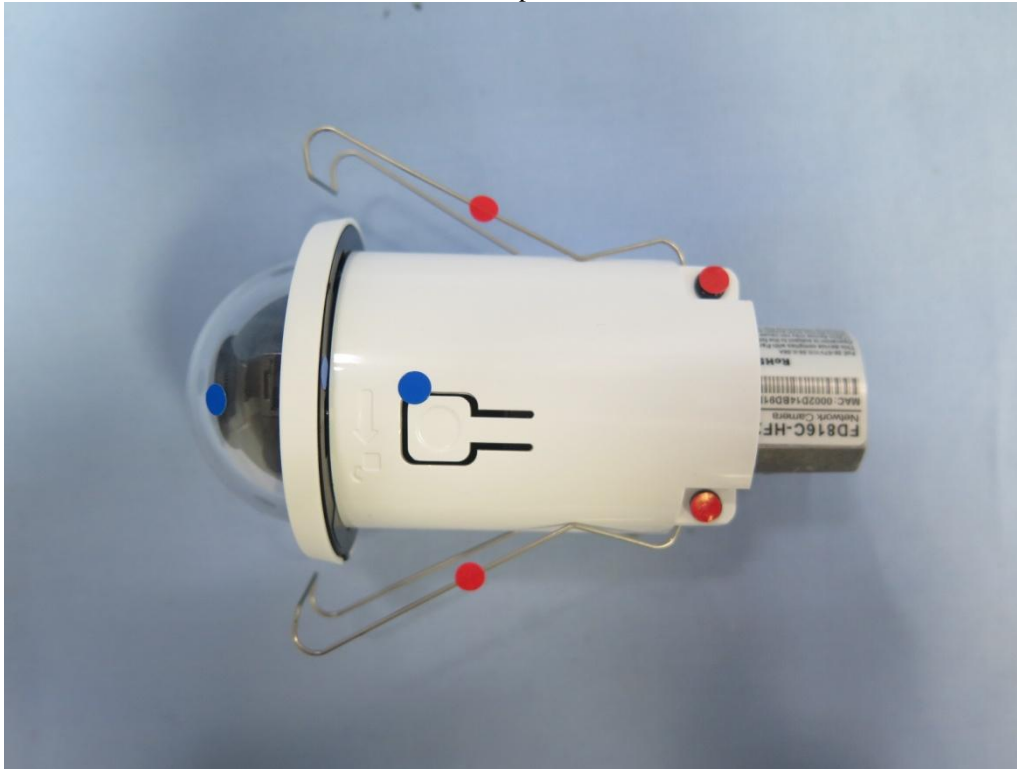

Bottom



*Red Dot - Contact Discharged
Blue Dot - Air Discharged

5.3.7 Photographs of Test Configuration

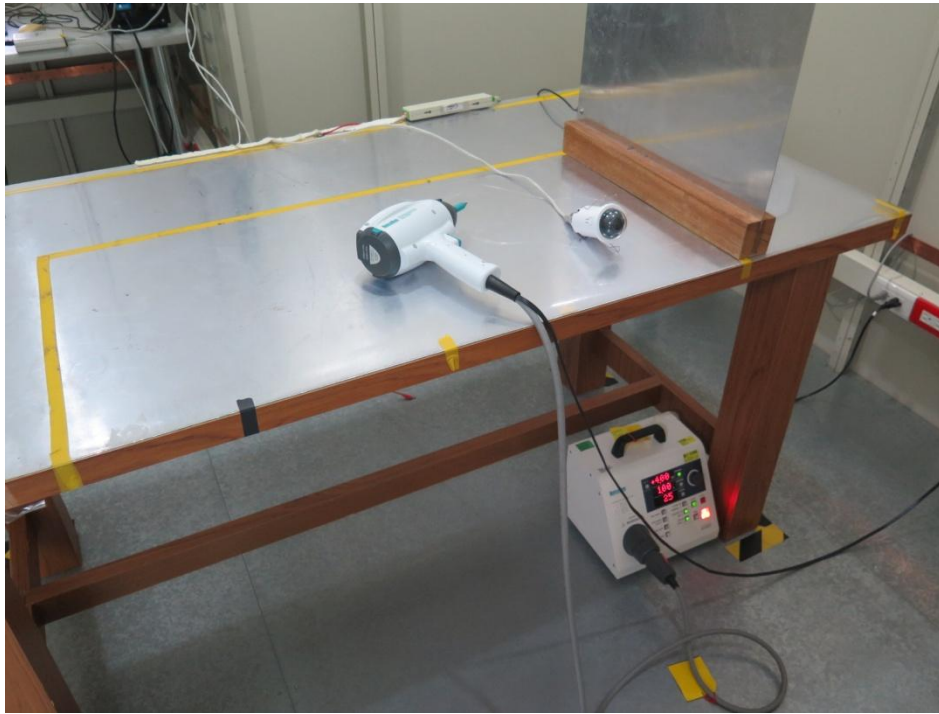

5.4 Radiated, Radio-frequency, Electromagnetic Field Immunity Test (RS)

5.4.1 Test Specification

Standard	IEC/EN 61000-4-3
Frequency Range	80 MHz - 1000 MHz
Field Strength	3 V/m
Modulation	80%, AM Modulation, 1 kHz Sine Wave
Frequency Step	1%
Polarity of Antenna	Horizontal and Vertical
Test Distance	3 m
Antenna Height	1.5 m
Dwell Time	3.0 seconds

5.4.2 Test Instrument

Item	Equipment	Manufacturer	Model	Meter No.	Calibration Date
1	RadiCentre ® Modular EMC Test Systems	DARE	CTR1004B	CT-1-080	No calibration request
2	RF Signal Generator	DARE	RGN6000B	CT-1-080	Aug. 01, 2016
3	LINEAR POWER RF AMPLIFIER	OPHIR	5225	CT-1-082	No calibration request
4	LINEAR POWER RF AMPLIFIER	OPHIR	5193	CT-1-083	No calibration request
5	LINEAR POWER RF AMPLIFIER	OPHIR	5022A	CT-1-084	No calibration request
6	Periodic Test-Antenna	Schwarzbeck Mess - Elektronik	STLP 9128 E	CT-1-085	No calibration request
7	Microwave Log.-Per. Antenna	Schwarzbeck Mess - Elektronik	ALX-4000E	CT-1-064	No calibration request
8	Electric Field Probe	FRANKONIA	EFS-10	CT-1-060a1	Aug. 2, 2016
9	Measurement Software	EMC-RS	Ver: 2.02	N/A	No calibration request

Note: 1. The calibration interval of the above test instruments is 12 months.

5.4.3 Test Procedure

The test procedure was in accordance with IEC 61000-4-3.

The EUT and load, which are placed on a table that is 0.8 meter above ground, are placed with one coincident with the calibration plane such that the distance from antenna to the EUT was 3 meters.

Both horizontal and vertical polarization of the antenna and four sides of the EUT are set on measurement.

In order to judge the EUT performance, a CCD camera is used to monitor EUT screen.

All the scanning conditions are as follows:

	Condition of Test	Remarks
1	Field Strength	3V/m
2	Radiated Signal	AM 80% Modulated with 1kHz
3	Scanning Frequency	80 M- 1000MHz
4	Dwell Time	3.0 Seconds
5	Frequency Step Size Δf	1%

5.4.4 Deviation from Test Standard

No deviation

5.4.5 Test Setup

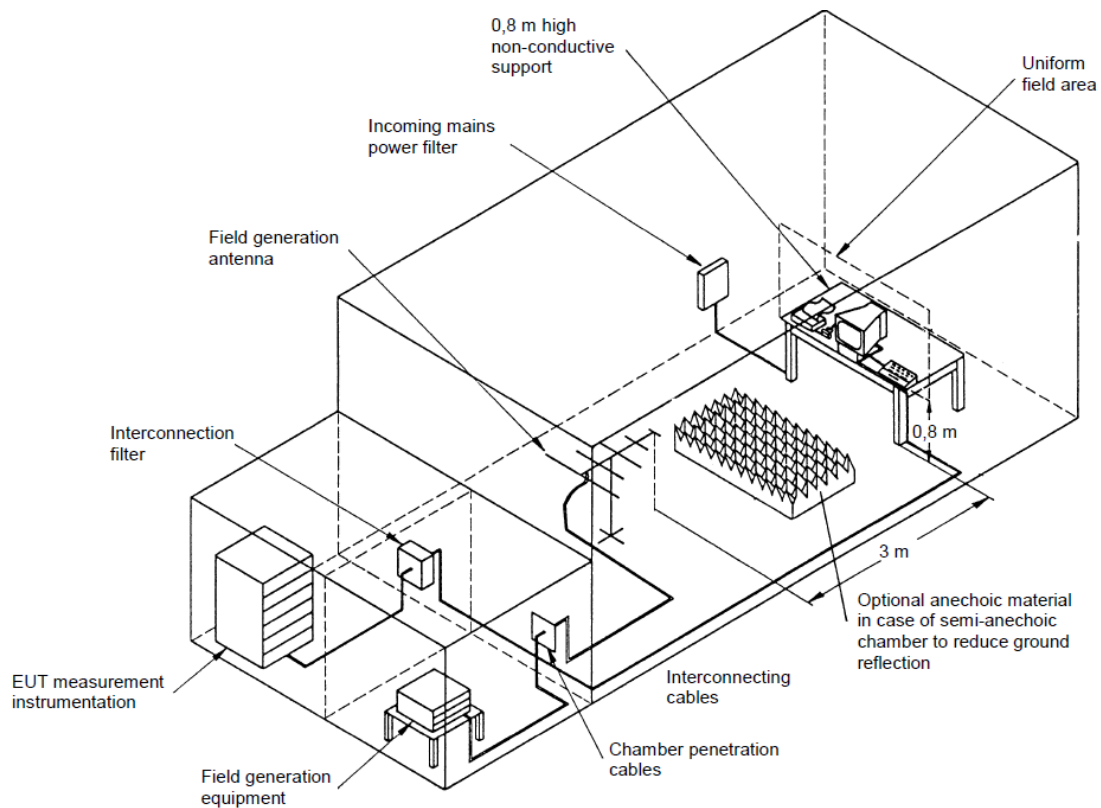

NOTE:

TABLETOP EQUIPMENT

The EUT installed in a representative system as described in section 7 of IEC 61000-4-3 was placed on a non-conductive table 0.8 meters in height.

FLOOR STANDING EQUIPMENT

The EUT installed in a representative system as described in section 7 of IEC 61000-4-3 was placed on a non-conductive wood support 0.1 meters in height.



5.4.6 Test Result

Test Voltage	48Vdc (from POE)	Environmental Conditions	24.9°C, 52% RH
Tested by	Eddy Tsai	Test Date	2016/11/02

Frequency Range (MHz)	Azimuth	Polarity	Field Strength (V/m)	Modulation	Result
80-1000	0	H/V	3	80% AM (1kHz)	A
80-1000	90	H/V	3	80% AM (1kHz)	A
80-1000	180	H/V	3	80% AM (1kHz)	A
80-1000	270	H/V	3	80% AM (1kHz)	A
80-1000	Top	H/V	3	80% AM (1kHz)	A
80-1000	Bottom	H/V	3	80% AM (1kHz)	A

Note:

Criteria A: The EUT function was correct during the test.

5.4.7 Photographs of Test Configuration

Front



Back

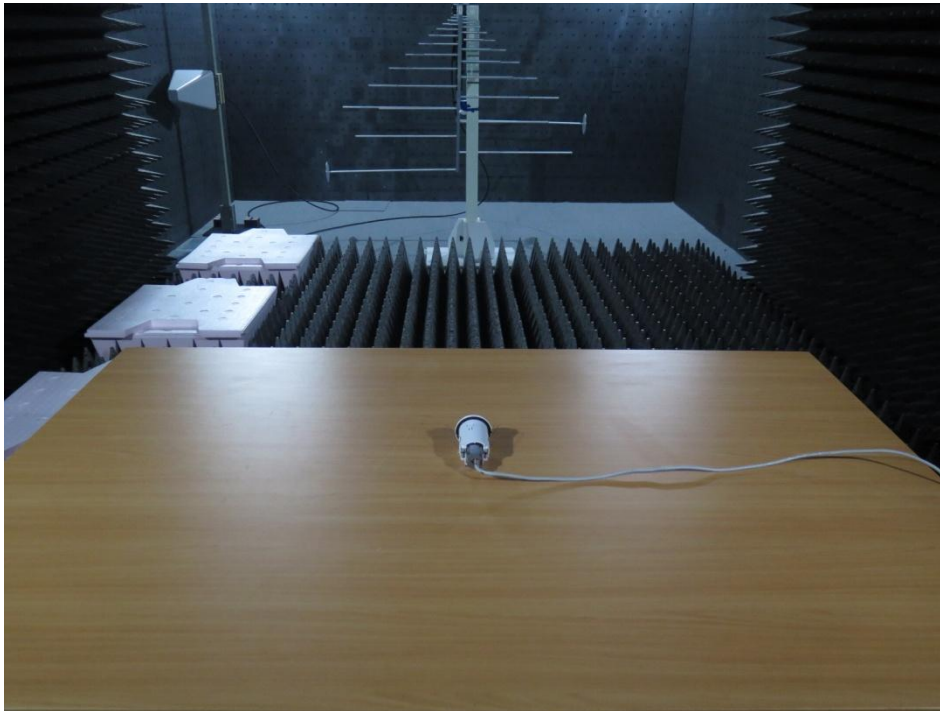

Left

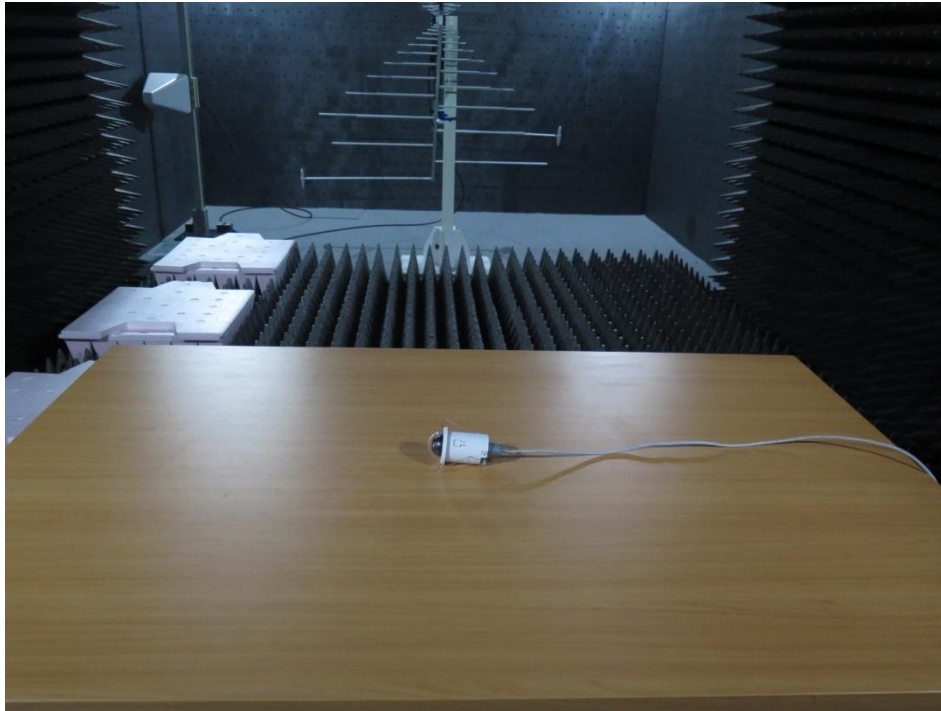

Right

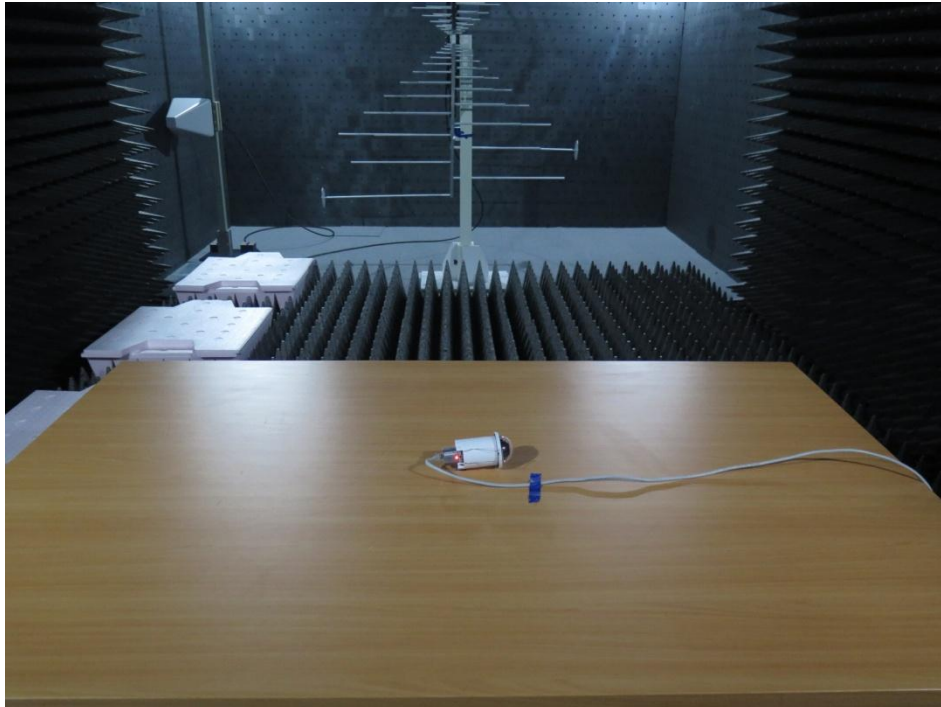

Top

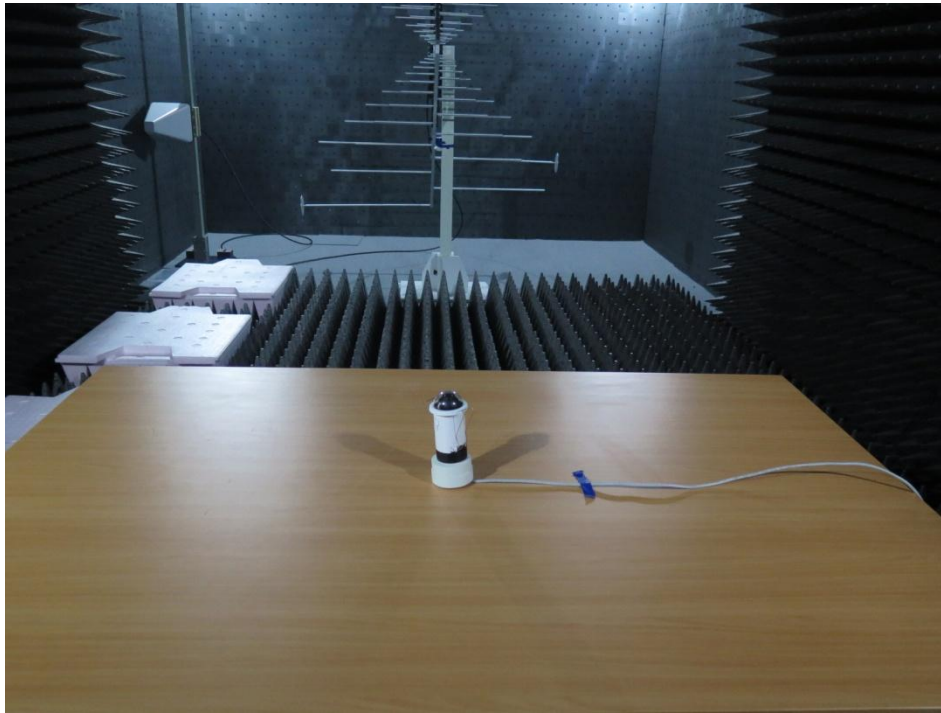

Bottom



5.5 Electrical Fast Transient /Burst Immunity Test (EFT)

5.5.1 Test Specification

Standard	IEC/EN 61000-4-4
Test Voltage	AC supply lines: ± 1 kV DC Power Port: ± 0.5 kV Signal ports and telecommunication ports: ± 0.5 kV
Polarity	Positive & Negative
Impulse Frequency	xDSL telecommunication port: 100 kHz other: 5kHz
Impulse Wave	5/50 ns
Burst Duration	15 ms
Burst Period	300 ms
Test Duration	Not less than 1 min.

5.5.2 Test Instrument

Item	Equipment	Manufacturer	Model	Meter No.	Calibration Date
1	EMS Generator	Thermo	EMC Pro	CT-1-030	Mar. 30, 2016
2	Clamp	KeyTek	CCL	CT-1-032	Mar. 30, 2016
3	Measurement Software	CEWare32	Ver: 4.1	N/A	No calibration request

Note: 1. The calibration interval of the above test instruments is 12 months.

5.5.3 Test Procedure

The EUT is placed on a table that is 0.8 meter height. A ground reference plane is placed on the table, and uses a 0.1m insulation between the EUT and ground reference plane.

The minimum area of the ground reference plane is 1m*1m, and 0.65mm thick min, and projected beyond the EUT by at least 0.1m on all sides.

For input AC power ports:

The EUT is connected to the power mains through a coupling device that directly couples the EFT/B interference signal.

Each of the line conductors is impressed with burst noise for 1 minute.

The length of the power lines between the coupling device and the EUT is 0.5m.

5.5.4 Deviation from Test Standard

No deviation

5.5.5 Test Setup

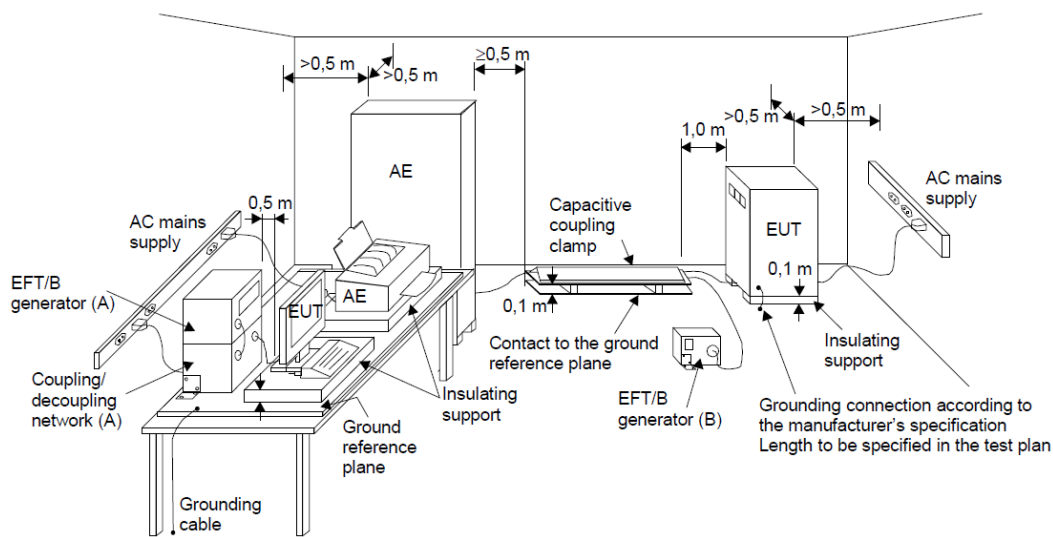

- (A) location for supply line coupling
- (B) location for signal lines coupling

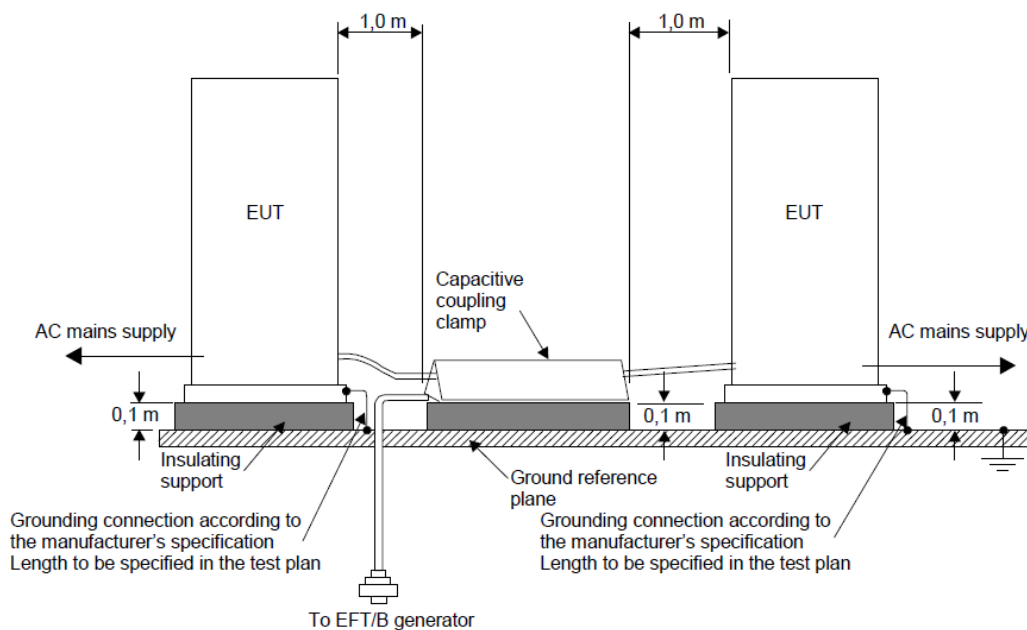



5.5.6 Test Result

Test Voltage	48Vdc (from POE)	Environmental Conditions	24.9°C, 52% RH
Tested by	Eddy Tsai	Test Date	2016/11/02

Test Point		Test Level (kV)	Polarity (+/-)	Result
Signal Ports Telecommunication Ports	RJ45	0.5	+/-	A

Note:

Criteria A: The EUT function was correct during the test.

5.5.7 Photographs of Test Configuration

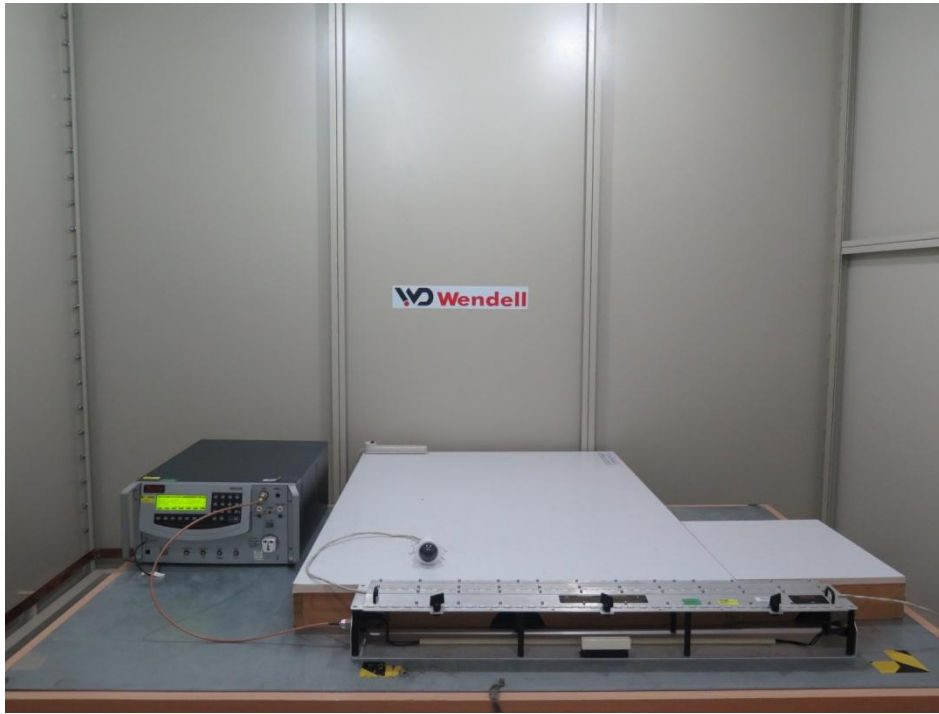

5.6 Surge Immunity Test

5.6.1 Test Specification

Standard	IEC/EN 61000-4-5
Wave- Shape	Signal and telecommunication ports(direct to outdoor cables ^(Note 1)): 10/700 μ s Open Circuit Voltage 5/320 μ s Short Circuit Current Input DC power port(direct to outdoor cables ^(Note 1)): 1.2/50 μ s Open Circuit Voltage 8/20 μ s Short Circuit Current Input AC Power ports: 1.2/50 μ s Open Circuit Voltage 8 /20 μ s Short Circuit Current
Test Voltage	Signal and telecommunication ports ^(Note 2) (direct to outdoor cables ^(Note 1)): w/o primary protectors: ± 1 kV, with primary protectors fitted: ± 4 kV Input DC power port(direct to outdoor cables ^(Note 1)): ± 0.5 kV, Input AC Power ports: Line to line: ± 1 kV, Line to ground: ± 2 kV
Surge Input / Output	L1-L2, L1-PE, L2-PE
Polarity	Positive/Negative
Phase Angle	0°/90°/180°/270°
Pulse Repetition Rate	1 time / min. (maximum)
Times	5 positive and 5 negative at selected points

- Note:** 1. This test is only applicable only to ports, which according to the manufacturer's specification, may connect directly to outdoor cables
2. For ports where primary protection is intended, surges are applied at voltages up to 4 kV with the primary protectors fitted. Otherwise the 1 kV test level is applied without primary protection in place.

5.6.2 Test Instrument

Item	Equipment	Manufacturer	Model	Meter No.	Calibration Date
1	EMS Generator	Thermo	EMC Pro	CT-1-030	Mar. 30, 2016
2	Surge CDN	3cTest	CDN-405T8A1	CT-1-074(5)	Mar. 31, 2016
3	Measurement Software	CEWare32	Ver: 4.1	N/A	No calibration request

- Note:** 1. The calibration interval of the above test instruments is 12 months.

5.6.3 Test Procedure

The EUT is placed on a table that is 0.8 meter above a metal ground plane measured 1m*1m minimum and 0.65mm thick minimum and projected beyond the EUT by at least 0.1m on all sides. The length of power cord between the coupling device and the EUT shall be 2m or less.

For input AC power ports:

The EUT is connected to the power mains through a coupling device that directly couples the surge interference signal.

The surge noise shall be applied synchronized to the voltage phase at 0°, 90°, 180°, 270° and the peak value of the AC voltage wave. (Positive and negative)

Each of Line to Earth and Line to Line is impressed with a sequence of five surge voltages with interval of 1 minute.

5.6.4 Deviation from Test Standard

No deviation

5.6.5 Test Setup

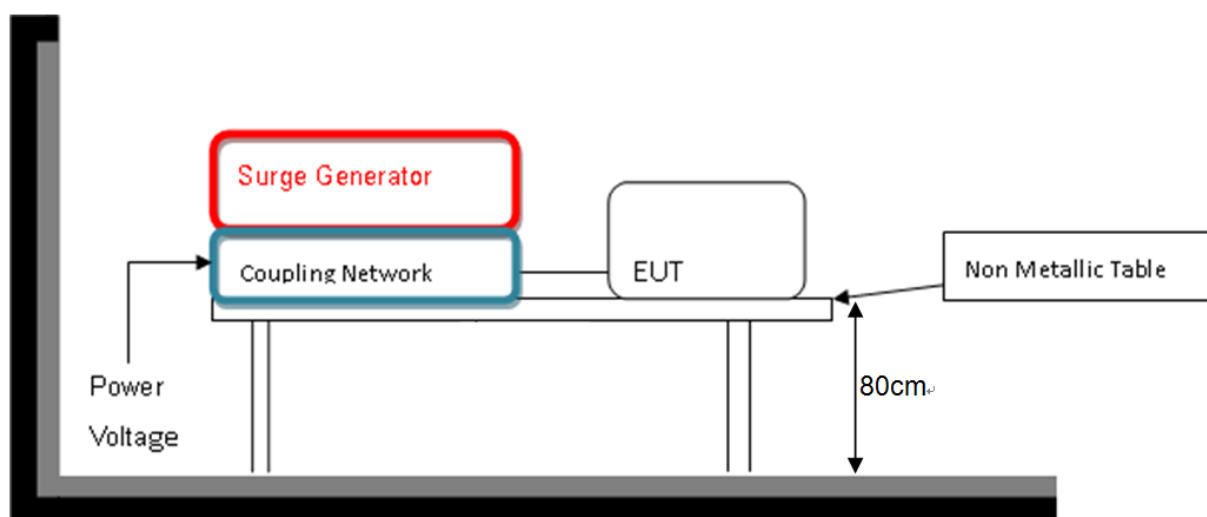



5.6.6 Test Result

Test Voltage	48Vdc (from POE)	Environmental Conditions	24.4°C, 52% RH
Tested by	Ken Huang	Test Date	2016/11/07

Signal Ports Telecommunication Ports (10/700 μ s Wave)					
Test Point	Polarity (+/-)	Test Level (kV)			Result
		0.5	1	2	
RJ45	+/-	B (#1)	B (#1)	B (#1)	B

Note:

Criteria A: The EUT function was correct during the test.

Criteria B: (#1) The LAN was interrupted during the test, but could self-recover to the initial operation after the test.

5.6.7 Photographs of Test Configuration



5.7 Continuous Conducted Disturbances (CS)

5.7.1 Test Specification

Standard	IEC/EN 61000-4-6
Frequency Range	0.15 MHz - 80 MHz
Voltage Level	3 V(rms)
Modulation	AM Modulation, 80%, 1 kHz Sine Wave
Frequency Step	1% of fundamental
Dwell Time	3 seconds

5.7.2 Test Instrument

Item	Equipment	Manufacturer	Model	Meter No.	Calibration Date
1	Coupling clamp according to IEC 6100-4-6	FRANKONIA	EMCL-2	CT-1-049	Mar. 30, 2016
2	CDN for power supply lines	FRANKONIA	CDN M2+M3	CT-1-054	Mar. 30, 2016
3	6 dB Attenuator	BIRD	75-A-FFN-06	CT-1-056	Mar. 29, 2016
4	Compact Immunity Test System acc	FRANKONIA	CIT-10/75	CT-1-057	Mar. 30, 2016
5	Measurement Software	HUBERT	Ver: 1.1.2	N/A	No calibration request

Note: 1. The calibration interval of the above test instruments is 12 months.

5.7.3 Test Procedure

The EUT is placed on 0.1m insulation table between the EUT and ground reference plane.

For input AC power ports:

The EUT is connected to the power mains through a coupling and decoupling networks for power supply lines. And directly couples the disturbances signal into EUT.

Auxiliary equipment (AE) required for the defined operation of the EUT according to the specifications of the product committee.

5.7.4 Deviation from Test Standard

No deviation

5.7.5 Test Setup

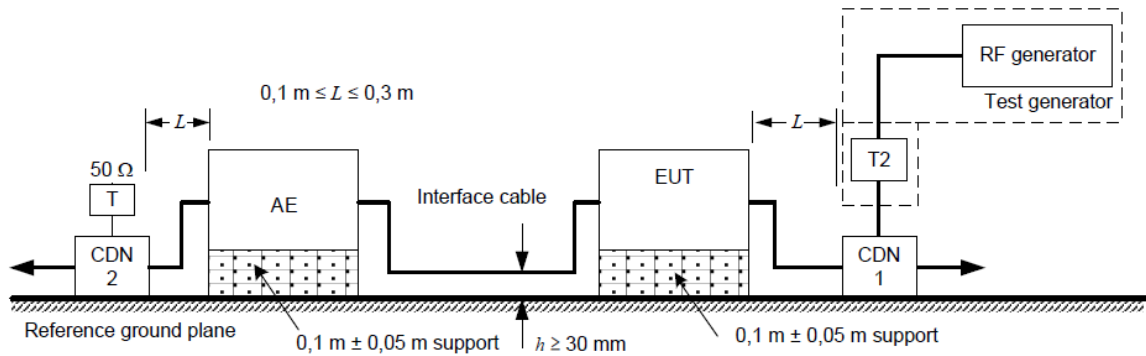

The interface cable is set at 1 m if possible.

a) Schematic setup for a 2-port EUT connected to only 1 CDN

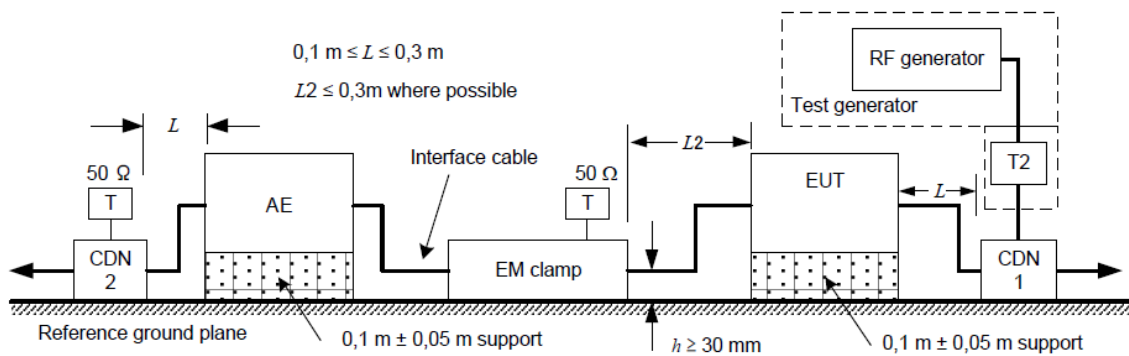

Note:

T: Termination 50 Ω

T2: Power attenuator (6 dB)

CDN: Coupling and decoupling network

Injection clamp: current clamp or EM clamp



5.7.6 Test Result

Test Voltage	48Vdc (from POE)	Environmental Conditions	24.7°C, 54% RH
Tested by	Eddy Tsai	Test Date	2016/11/02

Frequency Range (MHz)	Tested Port	Injection Method	Test Level (V_{r.m.s.})	Modulation	Result
0.15 - 80	RJ45	CLAMP	3	80% AM, 1kHz	A

Note:

Criteria A: The EUT function was correct during the test.

5.7.7 Photographs of Test Configuration

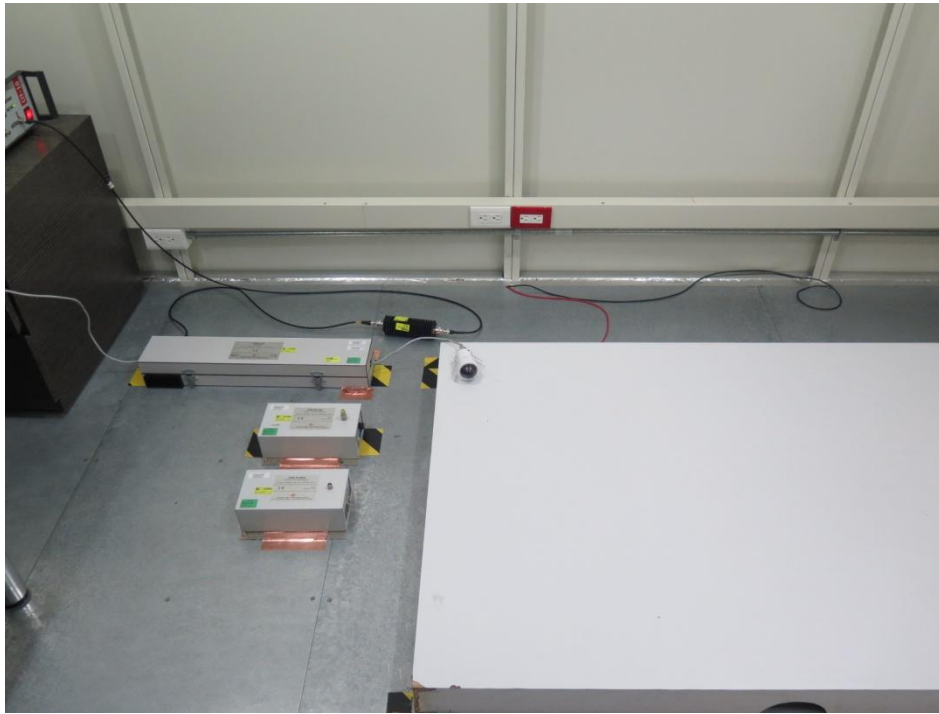

5.8 Power Frequency Magnetic Field Immunity Test

5.8.1 Test Specification

Standard	IEC/EN 61000-4-8
Frequency Range	50/60Hz
Field Strength	1 A/m
Observation Time	1 minute
Inductance Coil	Rectangular type, 1mx1m

5.8.2 Test Instrument

Item	Equipment	Manufacturer	Model	Meter No.	Calibration Date
1	PFMF	HAEFELY	MFS-100	CT-1-066	Aug. 02, 2016

Note: 1. The calibration interval of the above test instruments is 12 months.

5.8.3 Test Procedure

The EUT is placed on a table which is 0.8 meter above a metal ground plane measured at least 1m*1m minimum. The test magnetic field shall be placed at central of the induction coil.

The test magnetic Field shall be applied 10 minutes by the immersion method to the EUT, and the induction coil shall be rotated by 90° in order to expose the EUT to the test field with different orientation (X, Y, Z Orientations).

5.8.4 Deviation from Test Standard

No deviation

5.8.5 Test Setup

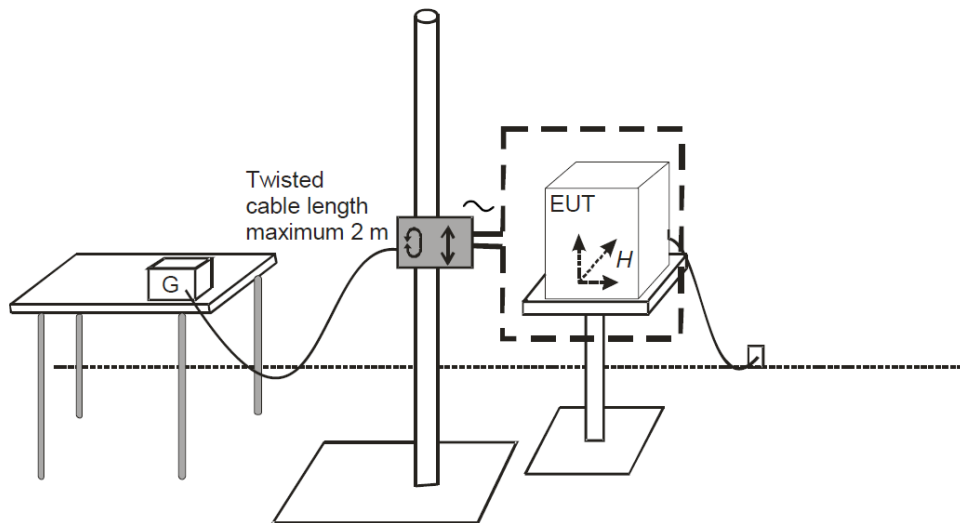

For the actual test configuration, please refer to 5.8.7.

NOTE:

TABLETOP EQUIPMENT

The equipment shall be subjected to the test magnetic field by using the induction coil of standard dimension (1 m x 1 m). The induction coil shall then be rotated by 90 degrees in order to expose the EUT to the test field with different orientations.

FLOOR-STANDING EQUIPMENT

The equipment shall be subjected to the test magnetic field by using induction coils of suitable dimensions. The test shall be repeated by moving and shifting the induction coils, in order to test the whole volume of the EUT for each orthogonal direction. The test shall be repeated with the coil shifted to different positions along the side of the EUT, in steps corresponding to 50 % of the shortest side of the coil. The induction coil shall then be rotated by 90 degrees in order to expose the EUT to the test field with different orientations.



5.8.6 Test Result

Test Voltage	48Vdc (from POE)	Environmental Conditions	24.9°C, 52% RH
Tested by	Eddy Tsai	Test Date	2016/11/02

Test Coil Position	Frequency (Hz)	Magnetic Strength (A/m)	Result
X - Axis	50/60	1	A
Y - Axis	50/60	1	A
Z - Axis	50/60	1	A

Note:

Criteria A: The EUT function was correct during the test.

5.8.7 Photographs of Test Configuration

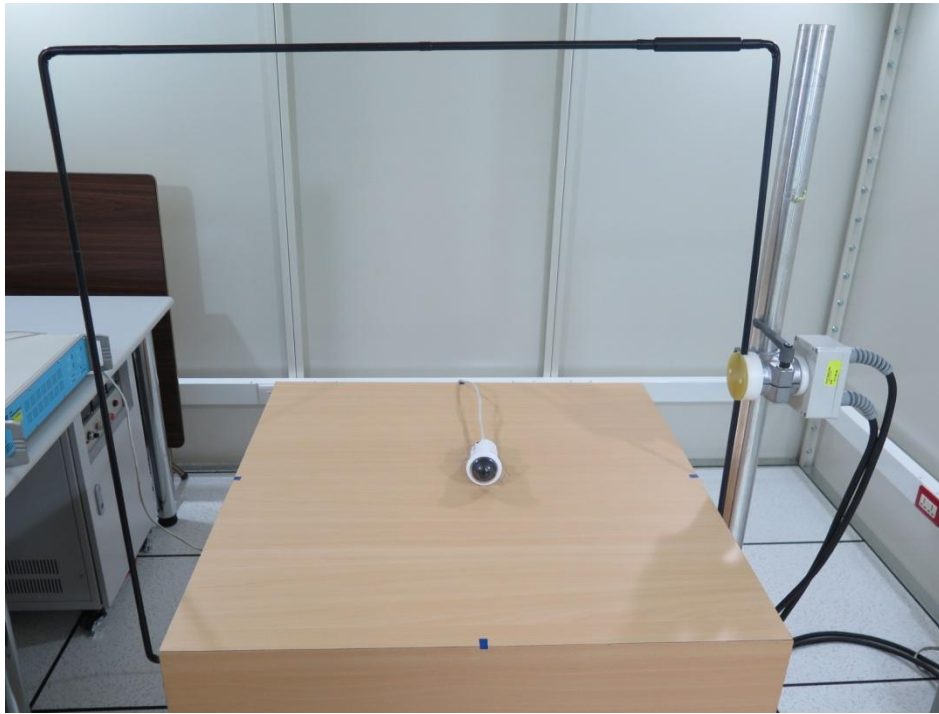



5.9 Voltage Dips & Short Interruptions

The test is determined no necessary for the EUT do not operate from the power lines or contain provisions for operation while connected to the power lines.

< End Page >