

FCC DoC Test Report

Report No.: FD170109D01

Test Model: IB8360-W

Received Date: Jan. 9, 2017

Test Date: Jan. 9 ~ 10, 2017

Issued Date: Jan. 18, 2017

Applicant: VIVOTEK INC.

Address: 6F, No.192, Lien-Cheng Rd., Chung-Ho , New Taipei City, 235, Taiwan,
R.O.C.

Issued By: Bureau Veritas Consumer Products Services (H.K.) Ltd., Taoyuan Branch

Lab Address: No. 47-2, 14th Ling, Chia Pau Vil., Lin Kou Dist., New Taipei City, Taiwan
(R.O.C.)



This report is for your exclusive use. Any copying or replication of this report to or for any other person or entity, or use of our name or trademark, is permitted only with our prior written permission. This report sets forth our findings solely with respect to the test samples identified herein. The results set forth in this report are not indicative or representative of the quality or characteristics of the lot from which a test sample was taken or any similar or identical product specifically and expressly noted. Our report includes all of the tests requested by you and the results thereof based upon the information that you provided to us. You have 60 days from date of issuance of this report to notify us of any material error or omission caused by our negligence, provided, however, that such notice shall be in writing and shall specifically address the issue you wish to raise. A failure to raise such issue within the prescribed time shall constitute your unqualified acceptance of the completeness of this report, the tests conducted and the correctness of the report contents. Unless specific mention, the uncertainty of measurement has been explicitly taken into account to declare the compliance or non-compliance to the specification. The report must not be used by the client to claim product certification, approval, or endorsement by NVLAP, NIST, or any agency of the federal government. The report must not be used by the client to claim product certification, approval, or endorsement by TAF or any government agencies.

Table of Contents

| | |
|--|-----------|
| Release Control Record..... | 3 |
| 1 Certificate of Conformity..... | 4 |
| 2 Summary of Test Results..... | 5 |
| 2.1 Measurement Uncertainty..... | 5 |
| 2.2 Modification Record..... | 5 |
| 3 General Information | 6 |
| 3.1 Features of EUT..... | 6 |
| 3.2 General Description of EUT..... | 6 |
| 3.3 Operating Modes of EUT and Determination of Worst Case Operating Mode..... | 6 |
| 3.4 Test Program Used and Operation Descriptions | 7 |
| 3.5 Primary Clock Frequencies of Internal Source | 7 |
| 4 Configuration and Connections with EUT..... | 8 |
| 4.1 Connection Diagram of EUT and Peripheral Devices | 8 |
| 4.2 Configuration of Peripheral Devices and Cable Connections..... | 8 |
| 5 Conducted Emissions at Mains Ports | 9 |
| 5.1 Limits | 9 |
| 5.2 Test Instruments..... | 9 |
| 5.3 Test Arrangement..... | 10 |
| 5.4 Test Results | 11 |
| 6 Radiated Emissions up to 1 GHz..... | 13 |
| 6.1 Limits | 13 |
| 6.2 Test Instruments..... | 13 |
| 6.3 Test Arrangement..... | 14 |
| 6.4 Test Results | 15 |
| 7 Radiated Emissions above 1 GHz | 17 |
| 7.1 Limits | 17 |
| 7.2 Test Instruments..... | 18 |
| 7.3 Test Arrangement..... | 19 |
| 7.4 Test Results | 20 |
| 8 Pictures of Test Arrangements | 22 |
| 8.1 Conducted Emissions at Mains Ports..... | 22 |
| 8.2 Radiated Emissions up to 1 GHz..... | 23 |
| 8.3 Radiated Emissions above 1 GHz | 24 |
| Appendix – Information on the Testing Laboratories..... | 25 |



Release Control Record

| Issue No. | Description | Date Issued |
|-------------|-------------------|---------------|
| FD170109D01 | Original release. | Jan. 18, 2017 |

1 Certificate of Conformity

Product: Network Camera
Brand: VIVOTEK
Test Model: IB8360-W
Sample Status: Engineering sample
Applicant: VIVOTEK INC.
Test Date: Jan. 9 ~ 10, 2017
Standards: 47 CFR FCC Part 15, Subpart B, Class B
ICES-003:2016 Issue 6, Class B
ANSI C63.4:2014

The above equipment has been tested by **Bureau Veritas Consumer Products Services (H.K.) Ltd., Taoyuan Branch**, and found compliance with the requirement of the above standards. The test record, data evaluation & Equipment Under Test (EUT) configurations represented herein are true and accurate accounts of the measurements of the sample's EMC characteristics under the conditions specified in this report.

Prepared by :  , **Date:** Jan. 18, 2017
Jessica Cheng / Senior Specialist

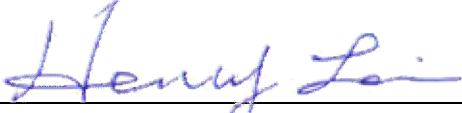
Approved by :  , **Date:** Jan. 18, 2017
Henry Lai / Director

2 Summary of Test Results

47 CFR FCC Part 15, Subpart B / ICES-003:2016 Issue 6, Class B

ANSI C63.4:2014

| FCC Clause | ICES-003 Clause | Test Item | Result/Remarks | Verdict |
|------------|-----------------|-----------------------------------|--|---------|
| 15.107 | 6.1 | AC Power Line Conducted Emissions | Minimum passing Class B margin is -16.51 dB at 0.53281 MHz | Pass |
| 15.109 | 6.2.1 | Radiated Emissions up to 1 GHz | Minimum passing Class B margin is -4.46 dB at 149.59 MHz | Pass |
| | 6.2.2 | Radiated Emissions above 1 GHz | Minimum passing Class B margin is -21.85 dB at 2892.87 MHz | Pass |

Note: There is no deviation to the applied test methods and requirements covered by the scope of this report.

2.1 Measurement Uncertainty

Where relevant, the following measurement uncertainty levels have been estimated for tests performed on the EUT:

The listed uncertainties are the worst case uncertainty for the entire range of measurement. Please note that the uncertainty values are provided for informational purposes only and are not used in determining the PASS/FAIL results.

| Measurement | Frequency | Expanded Uncertainty (k=2) (\pm) |
|------------------------------------|----------------|--------------------------------------|
| Conducted Emissions at mains ports | 150kHz ~ 30MHz | 2.77 dB |
| Radiated Emissions up to 1 GHz | 30MHz ~ 1GHz | 3.99 dB |
| Radiated Emissions above 1 GHz | 1GHz ~ 6GHz | 4.77 dB |
| | 6GHz ~ 18GHz | 5.48 dB |

2.2 Modification Record

There were no modifications required for compliance.

3 General Information

3.1 Features of EUT

The tests reported herein were performed according to the method specified by VIVOTEK INC., for detailed feature description, please refer to the manufacturer's specifications or user's manual.

3.2 General Description of EUT

| | |
|---------------------|--|
| Product | Network Camera |
| Brand | VIVOTEK |
| Test Model | IB8360-W |
| Sample Status | Engineering sample |
| Operating Software | N/A |
| Power Supply Rating | Refer to table as below |
| Accessory Device | Adapter |
| Data Cable Supplied | Non-shielded DC cable (0.3m) attached on EUT |

Note:

1. The EUT is a Network Camera with built-in a wireless module.

2. The EUT uses following adapter.

| | |
|--------------|--|
| Brand | Atech OEM Inc., |
| Model | ADS018K-X120150 |
| Input Power | 100-240Vac, 50-60Hz, 0.5A |
| Output Power | 12Vdc, 1.5A |
| Power Line | AC 2 Pin Non-Shielded DC cable (1.5m) |

3.3 Operating Modes of EUT and Determination of Worst Case Operating Mode

1. Test modes are presented in the report as below.

| Mode | Test Condition | Input Power |
|-------------------------|--------------------------------------|-------------|
| Conducted emission test | | |
| 1 | EUT with adapter + wireless function | 120Vac/60Hz |
| Radiated emission test | | |
| 1 | EUT with adapter + wireless function | 120Vac/60Hz |

3.4 Test Program Used and Operation Descriptions

- a. Connected the EUT with AC adapter.
- b. Turned on the power of all equipment.
- c. EUT captured video signal.
- d. EUT captured video signal to notebook (kept in a remote area) then it displayed messages on its screen simultaneously via Wireless Broadband Router.
- e. Steps c-d were repeated.

3.5 Primary Clock Frequencies of Internal Source

The highest frequency generated or used within the EUT or on which the EUT operates or tunes is 2.5GHz, provided by VIVOTEK INC., for detailed internal source, please refer to the manufacturer's specifications.

4 Configuration and Connections with EUT

4.1 Connection Diagram of EUT and Peripheral Devices

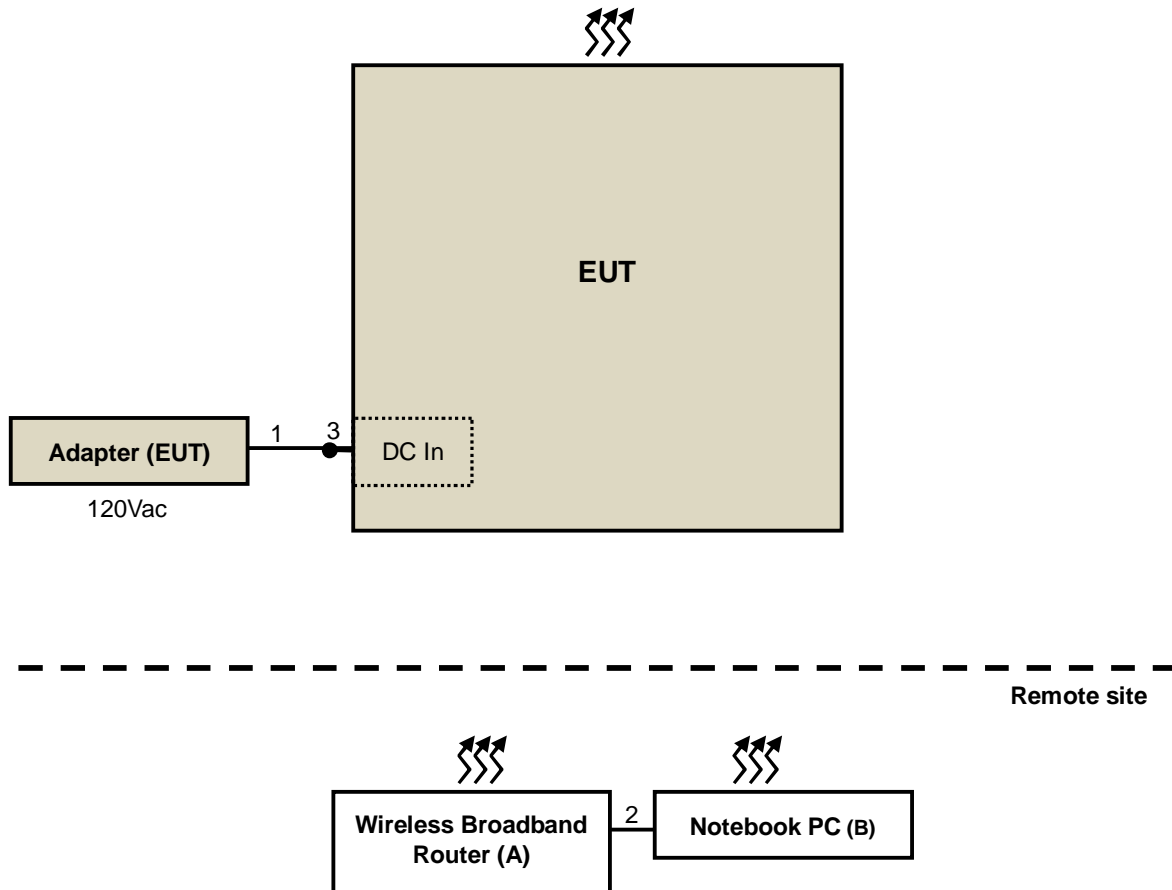

4.2 Configuration of Peripheral Devices and Cable Connections

| ID | Product | Brand | Model No. | Serial No. | FCC ID | Remarks |
|----|---------------------------|---------|-----------|---------------|------------------|--------------------|
| A. | Wireless Broadband Router | Netgear | D7000 | 4BC156B300005 | N/A | Su Provided by Lab |
| B. | NOTEBOOK COMPUTER | DELL | PP04X | 6C1VY1S | FCC DoC Approved | Provided by Lab |

Note:

1. All power cords of the above support units are non-shielded (1.8m).
2. Items A-B acted as communication partners to transfer data.

| ID | Descriptions | Qty. | Length (m) | Shielding (Yes/No) | Cores (Qty.) | Remarks |
|----|--------------|------|------------|--------------------|--------------|--------------------|
| 1. | DC cable | 1 | 1.5 | N | 0 | Supplied by client |
| 2. | LAN cable | 1 | 1.8 | N | 0 | Provided by Lab |
| 3. | DC cable | 1 | 0.3 | N | 0 | EUT |

Note: The core(s) is(are) originally attached to the cable(s).

5 Conducted Emissions at Mains Ports

5.1 Limits

| Frequency (MHz) | Class A (dBuV) | | Class B (dBuV) | |
|-----------------|----------------|---------|----------------|---------|
| | Quasi-peak | Average | Quasi-peak | Average |
| 0.15 - 0.5 | 79 | 66 | 66 - 56 | 56 - 46 |
| 0.50 - 5.0 | 73 | 60 | 56 | 46 |
| 5.0 - 30.0 | 73 | 60 | 60 | 50 |

Notes: 1. The lower limit shall apply at the transition frequencies.
2. The limit decreases linearly with the logarithm of the frequency in the range of 0.15 to 0.50 MHz.

5.2 Test Instruments

| Description & Manufacturer | Model No. | Serial No. | Cal. Date | Cal. Due |
|--|---------------|--------------|---------------|---------------|
| ROHDE & SCHWARZ TEST RECEIVER | ESCS 30 | 100276 | Apr. 12, 2016 | Apr. 11, 2017 |
| ROHDE & SCHWARZ Artificial Mains Network (for EUT) | ENV216 | 101197 | May 04, 2016 | May 03, 2017 |
| LISN With Adapter (for EUT) | AD10 | C10Ada-002 | May 04, 2016 | May 03, 2017 |
| ROHDE & SCHWARZ Artificial Mains Network (for peripherals) | ESH3-Z5 | 100218 | Nov. 23, 2016 | Nov. 22, 2017 |
| SCHWARZBECK Artificial Mains Network (For EUT) | NNLK8129 | 8129229 | May 04, 2016 | May 03, 2017 |
| Software | Cond_V7.3.7.4 | NA | NA | NA |
| RF cable (JYEBAO) With 10dB PAD | 5D-FB | Cable-C10.01 | Feb. 15, 2016 | Feb. 14, 2017 |
| SUHNER Terminator (For ROHDE & SCHWARZ LISN) | 65BNC-5001 | E1-011484 | May 12, 2016 | May 11, 2017 |
| ROHDE & SCHWARZ Artificial Mains Network (For TV EUT) | ESH3-Z5 | 100220 | Nov. 08, 2016 | Nov. 07, 2017 |
| LISN With Adapter (for TV EUT) | 100220 | N/A | Nov. 08, 2016 | Nov. 07, 2017 |

Notes: 1. The calibration interval of the above test instruments is 12 months and the calibrations are traceable to NML/ROC and NIST/USA.
2. The test was performed in Shielded Room No. 10.
3. The VCCI Site Registration No. C-1852.
4. Tested Date: Jan. 9, 2017.

5.3 Test Arrangement

- The EUT was placed 0.4 meters from the conducting wall of the shielded room with EUT being connected to the power mains through a line impedance stabilization network (LISN). Other support units were connected to the power mains through another LISN. The two LISNs provide 50 Ohm/ 50uH of coupling impedance for the measuring instrument.
- Both lines of the power mains connected to the EUT were checked for maximum conducted interference.
- The test results of conducted emissions at mains ports are recorded of six worst margins for quasi-peak (mandatory) [and average (if necessary)] values against the limits at frequencies of interest unless the margin is 20 dB or greater.

Note: The resolution bandwidth and video bandwidth of test receiver is 9kHz for quasi-peak detection (QP) and average detection (AV) at frequency 0.15MHz-30MHz.

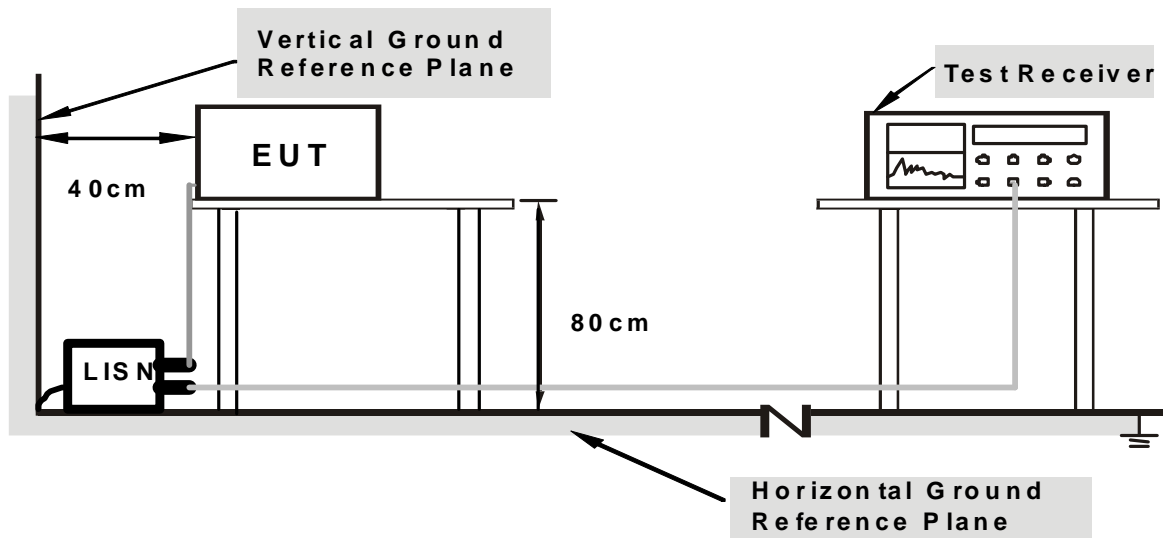

Note: Support units were connected to second LISN.

For the actual test configuration, please refer to the related item – Photographs of the Test Configuration.

5.4 Test Results

| | | | |
|------------------------|----------------|---|--------------------------------------|
| Frequency Range | 150kHz ~ 30MHz | Detector Function & Resolution Bandwidth | Quasi-Peak (QP) / Average (AV), 9kHz |
| Input Power | 120Vac, 60Hz | Environmental Conditions | 23°C, 75%RH |
| Tested by | Vincent Lin | | |
| Test Mode | Mode 1 | | |

| Phase Of Power : Line (L) | | | | | | | | | | |
|---------------------------|-----------------|------------------------|----------------------|--------------|-----------------------|--------------|--------------|--------------|---------------|---------------|
| No | Frequency (MHz) | Correction Factor (dB) | Reading Value (dBuV) | | Emission Level (dBuV) | | Limit (dBuV) | | Margin (dB) | |
| | | | Q.P. | AV. | Q.P. | AV. | Q.P. | AV. | Q.P. | AV. |
| 1 | 0.15000 | 9.70 | 39.56 | 22.50 | 49.26 | 32.20 | 66.00 | 56.00 | -16.74 | -23.80 |
| 2 | 0.17734 | 9.70 | 36.18 | 18.84 | 45.88 | 28.54 | 64.61 | 54.61 | -18.73 | -26.07 |
| 3 | 0.21641 | 9.70 | 32.12 | 15.38 | 41.82 | 25.08 | 62.96 | 52.96 | -21.14 | -27.88 |
| 4 | 0.53281 | 9.75 | 25.98 | 19.74 | 35.73 | 29.49 | 56.00 | 46.00 | -20.27 | -16.51 |
| 5 | 2.96094 | 9.99 | 11.77 | 3.63 | 21.76 | 13.62 | 56.00 | 46.00 | -34.24 | -32.38 |
| 6 | 14.07813 | 10.21 | 21.79 | 15.78 | 32.00 | 25.99 | 60.00 | 50.00 | -28.00 | -24.01 |

Remarks:

1. Q.P. and AV. are abbreviations of quasi-peak and average individually.
2. The emission levels of other frequencies were very low against the limit.
3. Margin value = Emission level – Limit value
4. Correction factor = Insertion loss + Cable loss
5. Emission Level = Correction Factor + Reading Value

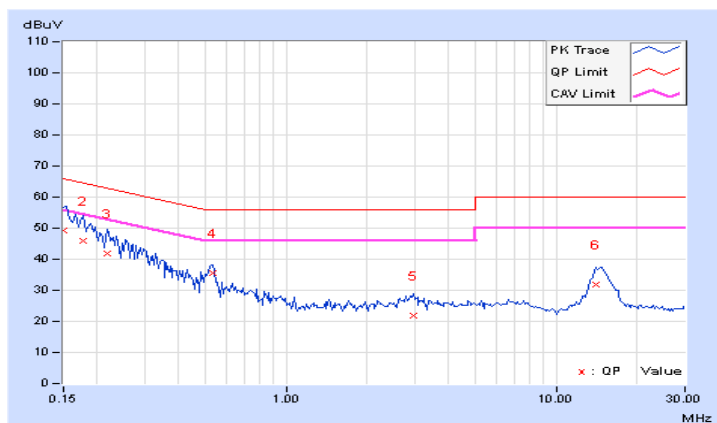

| | | | |
|------------------------|----------------|---|--------------------------------------|
| Frequency Range | 150kHz ~ 30MHz | Detector Function & Resolution Bandwidth | Quasi-Peak (QP) / Average (AV), 9kHz |
| Input Power | 120Vac, 60Hz | Environmental Conditions | 23°C, 75%RH |
| Tested by | Vincent Lin | | |
| Test Mode | Mode 1 | | |

| Phase Of Power : Neutral (N) | | | | | | | | | | |
|------------------------------|-----------------|------------------------|----------------------|-------|-----------------------|-------|--------------|-------|-------------|--------|
| No | Frequency (MHz) | Correction Factor (dB) | Reading Value (dBuV) | | Emission Level (dBuV) | | Limit (dBuV) | | Margin (dB) | |
| | | | Q.P. | AV. | Q.P. | AV. | Q.P. | AV. | Q.P. | AV. |
| 1 | 0.16172 | 9.70 | 36.19 | 16.83 | 45.89 | 26.53 | 65.38 | 55.38 | -19.49 | -28.85 |
| 2 | 0.21250 | 9.69 | 26.19 | 11.26 | 35.88 | 20.95 | 63.11 | 53.11 | -27.23 | -32.16 |
| 3 | 0.33359 | 9.72 | 18.39 | 5.52 | 28.11 | 15.24 | 59.36 | 49.36 | -31.25 | -34.12 |
| 4 | 0.54063 | 9.75 | 25.31 | 18.41 | 35.06 | 28.16 | 56.00 | 46.00 | -20.94 | -17.84 |
| 5 | 3.15234 | 10.02 | 12.42 | 4.23 | 22.44 | 14.25 | 56.00 | 46.00 | -33.56 | -31.75 |
| 6 | 14.54688 | 10.24 | 23.93 | 17.81 | 34.17 | 28.05 | 60.00 | 50.00 | -25.83 | -21.95 |

Remarks:

1. Q.P. and AV. are abbreviations of quasi-peak and average individually.
2. The emission levels of other frequencies were very low against the limit.
3. Margin value = Emission level – Limit value
4. Correction factor = Insertion loss + Cable loss
5. Emission Level = Correction Factor + Reading Value

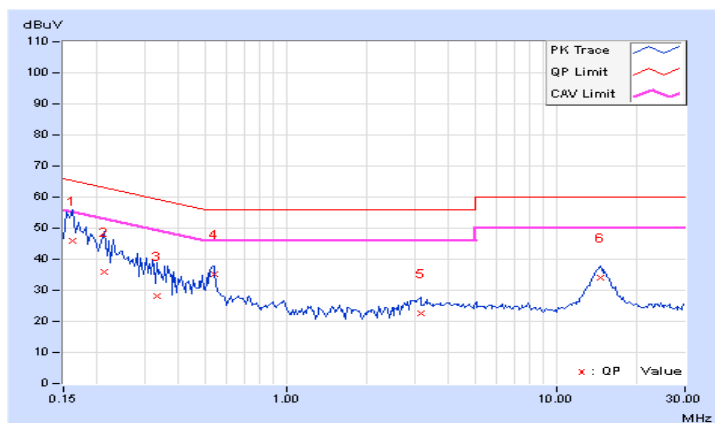

6 Radiated Emissions up to 1 GHz

6.1 Limits

Emissions radiated outside of the specified bands, shall be according to the general radiated limits as following:

| Radiated Emissions Limits at 10 meters (dB μ V/m) | | | | |
|---|-----------------------------|-----------------------------|-------------------|-------------------|
| Frequencies (MHz) | FCC 15B / ICES-003, Class A | FCC 15B / ICES-003, Class B | CISPR 22, Class A | CISPR 22, Class B |
| 30-88 | 39 | 29.5 | 40 | 30 |
| 88-216 | 43.5 | 33.1 | | |
| 216-230 | 46.4 | 35.6 | | |
| 230-960 | | | 47 | 37 |
| 960-1000 | 49.5 | 43.5 | | |

| Radiated Emissions Limits at 3 meters (dB μ V/m) | | | | |
|--|-----------------------------|-----------------------------|-------------------|-------------------|
| Frequencies (MHz) | FCC 15B / ICES-003, Class A | FCC 15B / ICES-003, Class B | CISPR 22, Class A | CISPR 22, Class B |
| 30-88 | 49.5 | 40 | 50.5 | 40.5 |
| 88-216 | 54 | 43.5 | | |
| 216-230 | 56.9 | 46 | | |
| 230-960 | | | 57.5 | 47.5 |
| 960-1000 | 60 | 54 | | |

- Notes:
1. The lower limit shall apply at the transition frequencies.
 2. Emission level (dB μ V/m) = 20 log Emission level (uV/m).
 3. QP detector shall be applied if not specified.

6.2 Test Instruments

| Description & Manufacturer | Model No. | Serial No. | Cal. Date | Cal. Due |
|----------------------------------|----------------------|--------------|---------------|---------------|
| ROHDE & SCHWARZ TEST RECEIVER | ESCS 30 | 845552/004 | Sep. 19, 2016 | Sep. 18, 2017 |
| Schaffner Bilog Antenna | CBL6111D | 22262 | Dec. 28, 2016 | Dec. 27, 2017 |
| ADT. Turn Table | TT100 | 0205 | NA | NA |
| ADT. Tower | AT100 | 0205 | NA | NA |
| Software | Radiated_V7.6.15.9.5 | NA | NA | NA |
| ADT RF Switches BOX | EMH-011 | 1001 | Feb. 15, 2016 | Feb. 14, 2017 |
| Pacific RF cable With 5dB PAD | 8D | CABLE-ST2-01 | Feb. 15, 2016 | Feb. 14, 2017 |

- Notes:
1. The calibration interval of the above test instruments is 12 months and the calibrations are traceable to NML/ROC and NIST/USA.
 2. The test was performed in Open Site No. 2.
 3. The VCCI Site Registration No. R-237.
 4. The FCC Site Registration No. 90424.
 5. Tested Date: Jan. 10, 2017.

6.3 Test Arrangement

- The EUT was placed on the top of a rotating table 0.8 meters above the ground at an accredited test facility. The table was rotated 360 degrees to determine the position of the highest radiation.
- The EUT was set 10 meters away from the interference-receiving antenna, which was mounted on the top of a variable-height antenna tower.
- The antenna is a broadband antenna, and its height is varied from one meter to four meters above the ground to determine the maximum value of the field strength. Both horizontal and vertical polarizations of the antenna are set to make the measurement.
- For each suspected emission, the EUT was arranged to its worst case and then the antenna was tuned to heights from 1 meter to 4 meters and the rotatable table was turned from 0 degrees to 360 degrees to find the maximum reading.
- The test-receiver system was set to quasi-peak detect function and specified bandwidth with maximum hold mode when the test frequency is up to 1 GHz.

Note: The resolution bandwidth and video bandwidth of test receiver/spectrum analyzer is 120kHz for quasi-peak detection (QP) at frequency up to 1GHz.

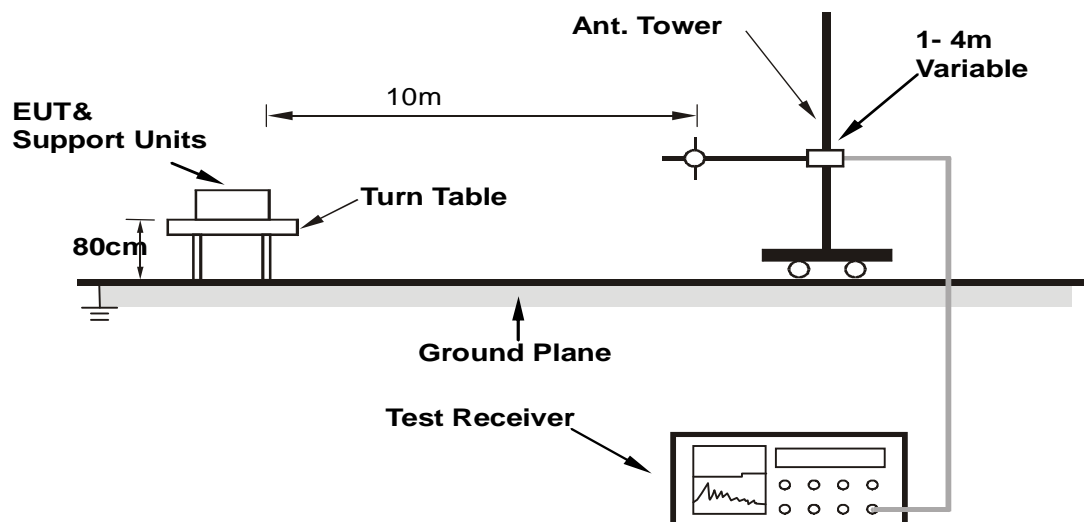

For the actual test configuration, please refer to the related item – Photographs of the Test Configuration.

6.4 Test Results

| | | | |
|------------------------|---------------|---|-------------------------|
| Frequency Range | 30MHz ~ 1GHz | Detector Function & Resolution Bandwidth | Quasi-Peak (QP), 120kHz |
| Input Power | 120Vac, 60Hz | Environmental Conditions | 21°C, 71%RH |
| Tested by | Vhenson Huang | | |
| Test Mode | Mode 1 | | |

Antenna Polarity & Test Distance : Horizontal at 10 m

| No | Frequency (MHz) | Emission Level (dBuV/m) | Limit (dBuV/m) | Margin (dB) | Antenna Height (m) | Table Angle (Degree) | Raw Value (dBuV) | Correction Factor (dB/m) |
|----|-----------------|-------------------------|----------------|-------------|--------------------|----------------------|------------------|--------------------------|
| 1 | 71.92 | 22.15 QP | 30.00 | -7.85 | 4.00 H | 179 | 39.38 | -17.23 |
| 2 | 115.34 | 20.08 QP | 30.00 | -9.92 | 4.00 H | 119 | 32.20 | -12.12 |
| 3 | 136.26 | 22.29 QP | 30.00 | -7.71 | 4.00 H | 131 | 33.92 | -11.63 |
| 4 | 197.73 | 20.82 QP | 30.00 | -9.18 | 4.00 H | 111 | 34.41 | -13.59 |
| 5 | 274.55 | 27.91 QP | 37.00 | -9.09 | 3.14 H | 182 | 37.15 | -9.24 |
| 6 | 380.18 | 29.04 QP | 37.00 | -7.96 | 2.49 H | 169 | 35.50 | -6.46 |
| 7 | 617.77 | 28.11 QP | 37.00 | -8.89 | 1.50 H | 159 | 29.76 | -1.65 |
| 8 | 720.91 | 31.46 QP | 37.00 | -5.54 | 1.00 H | 122 | 31.50 | -0.04 |
| 9 | 960.06 | 31.15 QP | 37.00 | -5.85 | 1.05 H | 230 | 26.26 | 4.89 |

Remarks:

1. Emission Level(dBuV/m) = Raw Value(dBuV) + Correction Factor(dB/m)
2. Correction Factor(dB/m) = Antenna Factor (dB/m) + Cable Factor (dB) – Pre-Amplifier Factor (dB)
3. The other emission levels were very low against the limit.
4. Margin value = Emission level – Limit value

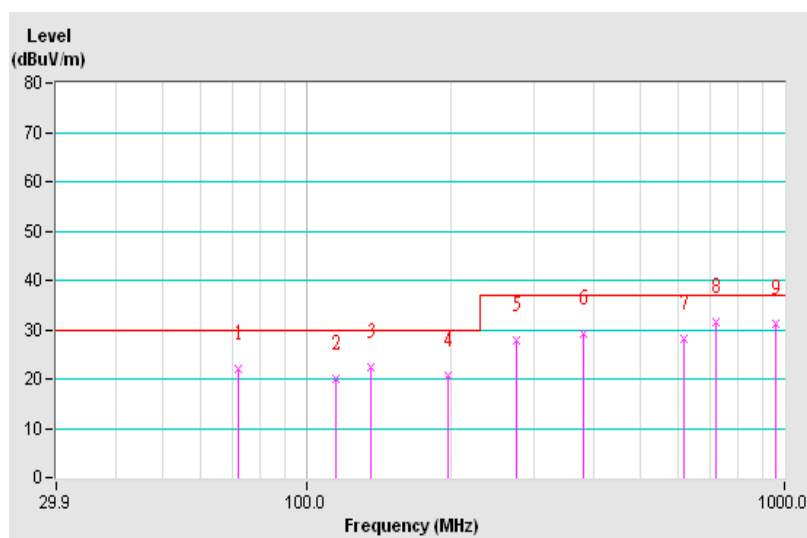

| | | | |
|------------------------|---------------|---|-------------------------|
| Frequency Range | 30MHz ~ 1GHz | Detector Function & Resolution Bandwidth | Quasi-Peak (QP), 120kHz |
| Input Power | 120Vac, 60Hz | Environmental Conditions | 21°C, 71%RH |
| Tested by | Vhenson Huang | | |
| Test Mode | Mode 1 | | |

| Antenna Polarity & Test Distance : Vertical at 10 m | | | | | | | | |
|---|-----------------|-------------------------|----------------|--------------|--------------------|----------------------|------------------|--------------------------|
| No | Frequency (MHz) | Emission Level (dBuV/m) | Limit (dBuV/m) | Margin (dB) | Antenna Height (m) | Table Angle (Degree) | Raw Value (dBuV) | Correction Factor (dB/m) |
| 1 | 43.34 | 24.78 QP | 30.00 | -5.22 | 1.65 V | 179 | 37.85 | -13.07 |
| 2 | 60.59 | 24.98 QP | 30.00 | -5.02 | 1.45 V | 138 | 43.14 | -18.16 |
| 3 | 81.33 | 22.23 QP | 30.00 | -7.77 | 1.36 V | 184 | 38.58 | -16.35 |
| 4 | 110.22 | 22.02 QP | 30.00 | -7.98 | 1.00 V | 50 | 34.58 | -12.56 |
| 5 | 133.41 | 22.90 QP | 30.00 | -7.10 | 1.00 V | 143 | 34.50 | -11.60 |
| 6 | 149.59 | 25.54 QP | 30.00 | -4.46 | 1.00 V | 118 | 37.64 | -12.10 |
| 7 | 217.54 | 20.76 QP | 30.00 | -9.24 | 1.00 V | 158 | 33.84 | -13.08 |
| 8 | 266.07 | 28.05 QP | 37.00 | -8.95 | 1.00 V | 313 | 37.26 | -9.21 |
| 9 | 376.70 | 31.78 QP | 37.00 | -5.22 | 1.00 V | 279 | 38.44 | -6.66 |
| 10 | 432.58 | 28.12 QP | 37.00 | -8.88 | 2.33 V | 211 | 33.26 | -5.14 |
| 11 | 644.12 | 31.58 QP | 37.00 | -5.42 | 2.90 V | 135 | 33.04 | -1.46 |
| 12 | 960.03 | 31.01 QP | 37.00 | -5.99 | 2.14 V | 131 | 26.12 | 4.89 |

Remarks:

1. Emission Level(dBuV/m) = Raw Value(dBuV) + Correction Factor(dB/m)
2. Correction Factor(dB/m) = Antenna Factor (dB/m) + Cable Factor (dB) – Pre-Amplifier Factor (dB)
3. The other emission levels were very low against the limit.
4. Margin value = Emission level – Limit value

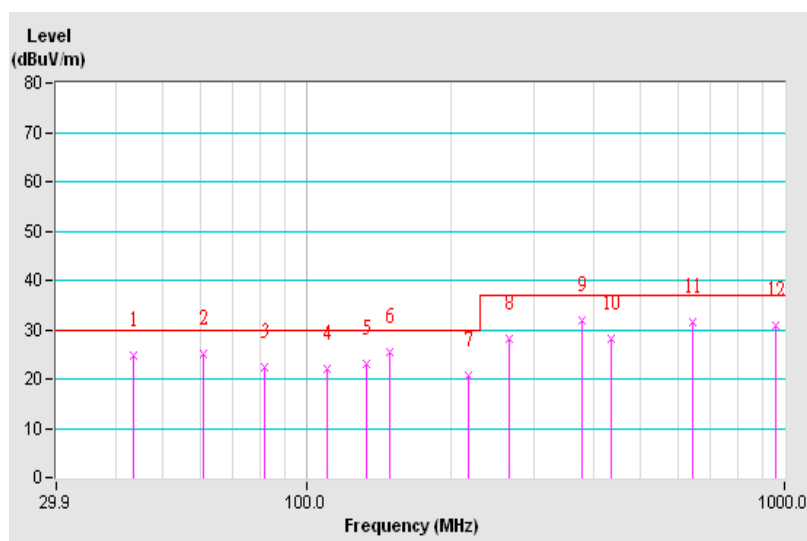

7 Radiated Emissions above 1 GHz

7.1 Limits

Emissions radiated outside of the specified bands, shall be according to the general radiated limits as following:

| Radiated Emissions Limits at 10 meters (dB μ V/m) | | | | |
|---|-----------------------------|-----------------------------|-------------------|-------------------|
| Frequencies (MHz) | FCC 15B / ICES-003, Class A | FCC 15B / ICES-003, Class B | CISPR 22, Class A | CISPR 22, Class B |
| 1000-3000 | Avg: 49.5 | Avg: 43.5 | Not defined | Not defined |
| Above 3000 | Peak: 69.5 | Peak: 63.5 | Not defined | Not defined |

| Radiated Emissions Limits at 3 meters (dB μ V/m) | | | | |
|--|-----------------------------|-----------------------------|---------------------|---------------------|
| Frequencies (MHz) | FCC 15B / ICES-003, Class A | FCC 15B / ICES-003, Class B | CISPR 22, Class A | CISPR 22, Class B |
| 1000-3000 | Avg: 60 | Avg: 54 | Avg: 56 Peak: 76 | Avg: 50 Peak: 70 |
| Above 3000 | Peak: 80 | Peak: 74 | Avg: 60 Peak: 80 | Avg: 54 Peak: 74 |

- Notes: 1. The lower limit shall apply at the transition frequencies.
 2. Emission level (dB μ V/m) = 20 log Emission level (uV/m).
 3. As shown in 15.35(b), for frequencies above 1000MHz, the field strength limits are based on average detector, however, the peak field strength of any emission shall not exceed the maximum permitted average limits, specified above by more than 20dB under any condition of modulation.

Frequency Range (For unintentional radiators)

| Highest frequency generated or used in the device or on which the device operates or tunes (MHz) | Upper frequency of measurement range (MHz) |
|--|--|
| Below 1.705 | 30 |
| 1.705-108 | 1000 |
| 108-500 | 2000 |
| 500-1000 | 5000 |
| Above 1000 | 5th harmonic of the highest frequency or 40GHz, whichever is lower |

7.2 Test Instruments

| Description & Manufacturer | Model No. | Serial No. | Cal. Date | Cal. Due |
|------------------------------|---------------------|--------------------|---------------|---------------|
| Agilent Spectrum | E4446A | MY51100009 | May 30, 2016 | May 29, 2017 |
| Agilent Test Receiver | N9038A | MY51210129 | Feb. 02, 2016 | Feb. 01, 2017 |
| Agilent Preamplifier | 8449B | 3008A01201 | Feb. 26, 2016 | Feb. 25, 2017 |
| MITEQ Preamplifier | AMF-6F-260400-33-8P | 892164 | Mar. 01, 2016 | Feb. 28, 2017 |
| EMCI Preamplifier | EMC184045B | 980235 | Mar. 01, 2016 | Feb. 28, 2017 |
| Schwarzbeck Horn Antenna | BBHA-9170 | 212 | Dec. 30, 2016 | Dec. 29, 2017 |
| Schwarzbeck Horn Antenna | BBHA 9120-D1 | D130 | Dec. 27, 2016 | Dec. 26, 2017 |
| ADT. Turn Table | TT100 | 0306 | NA | NA |
| ADT. Tower | AT100 | 0306 | NA | NA |
| Software | Radiated_V8.7.08 | NA | NA | NA |
| SUHNER RF cable With 4dB PAD | SF104 | Cable-CH6 | Aug. 15, 2016 | Aug. 14, 2017 |
| SUHNER RF cable With 3dB PAD | SF102 | Cable-CH8-02(3.6m) | Aug. 15, 2016 | Aug. 14, 2017 |

- Notes: 1. The calibration interval of the above test instruments is 12 months and the calibrations are traceable to NML/ROC and NIST/USA.
2. The test was performed in Chamber No. 6.
3. The Industry Canada Reference No. IC 7450E-6.
4. The VCCI Site Registration No. G-257.
5. The FCC Site Registration No. 447212.
6. Tested Date: Jan. 9, 2017.

7.3 Test Arrangement

- The EUT was placed on the top of a rotating table 0.8 meters above the ground at an accredited chamber room. The table was rotated 360 degrees to determine the position of the highest radiation.
- The EUT was set 3 meters away from the interference-receiving antenna, which was mounted on the top of a variable-height antenna tower.
- The height of antenna can be varied from one meter to four meters, the height of adjustment depends on the EUT height and the antenna 3dB beamwidth both, to detect the maximum value of the field strength. Both horizontal and vertical polarizations of the antenna are set to make the measurement.
- For each suspected emission, the EUT was arranged to its worst case and then the antenna was tuned to heights and the rotatable table was turned from 0 degrees to 360 degrees to find the maximum reading.
- The spectrum analyzer system was set to peak and average detect function and specified bandwidth with maximum hold mode when the test frequency is above 1 GHz.

Note: The resolution bandwidth of test receiver/spectrum analyzer is 1MHz and video bandwidth is 3MHz for Peak detection (PK) at frequency above 1GHz. The resolution bandwidth of test receiver/spectrum analyzer is 1 MHz for Average detection (AV) at frequency above 1GHz.

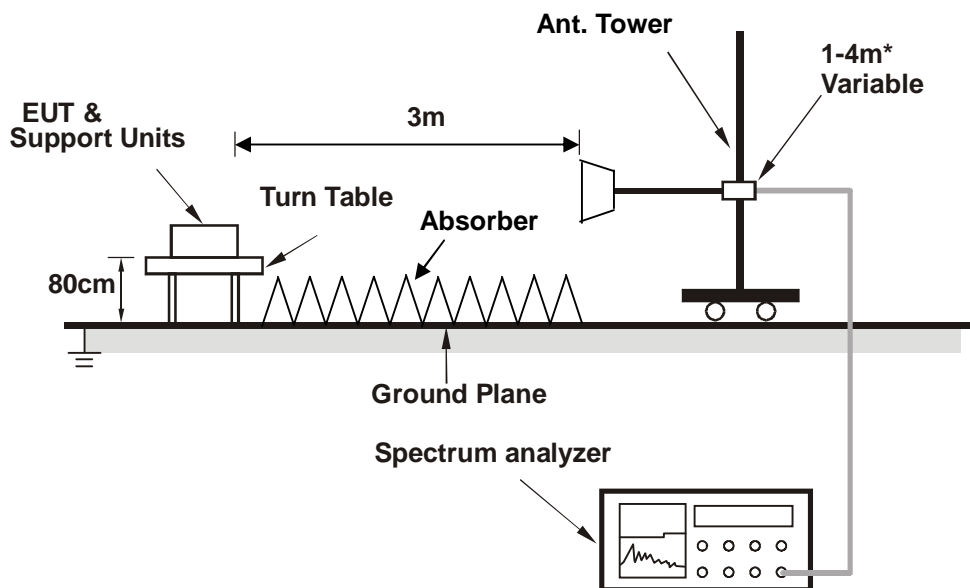

* :depends on the EUT height and the antenna 3dB beamwidth both.

For the actual test configuration, please refer to the related item – Photographs of the Test Configuration.

7.4 Test Results

| | | | |
|------------------------|----------------|---|--------------------------------|
| Frequency Range | 1GHz ~ 12.5GHz | Detector Function & Resolution Bandwidth | Peak (PK) / Average (AV), 1MHz |
| Input Power | 120Vac, 60Hz | Environmental Conditions | 20°C, 65%RH |
| Tested by | Dalen Dai | | |
| Test Mode | Mode 1 | | |

| Antenna Polarity & Test Distance : Horizontal at 3 m | | | | | | | | |
|--|-----------------|-------------------------|----------------|-------------|--------------------|----------------------|------------------|--------------------------|
| No | Frequency (MHz) | Emission Level (dBuV/m) | Limit (dBuV/m) | Margin (dB) | Antenna Height (m) | Table Angle (Degree) | Raw Value (dBuV) | Correction Factor (dB/m) |
| 1 | 1334.15 | 47.06 PK | 74.00 | -26.94 | 1.54 H | 85 | 51.12 | -4.06 |
| 2 | 1334.15 | 30.11 AV | 54.00 | -23.89 | 1.54 H | 85 | 34.17 | -4.06 |
| 3 | 1867.39 | 46.92 PK | 74.00 | -27.08 | 1.22 H | 170 | 49.23 | -2.31 |
| 4 | 1867.39 | 30.81 AV | 54.00 | -23.19 | 1.22 H | 170 | 33.12 | -2.31 |
| 5 | 3189.27 | 49.80 PK | 74.00 | -24.20 | 1.77 H | 343 | 47.03 | 2.77 |
| 6 | 3189.27 | 32.13 AV | 54.00 | -21.87 | 1.77 H | 343 | 29.36 | 2.77 |

Remarks:

1. Emission Level(dBuV/m) = Raw Value(dBuV) + Correction Factor(dB/m)
2. Correction Factor(dB/m) = Antenna Factor (dB/m) + Cable Factor (dB) – Pre-Amplifier Factor (dB)
3. The other emission levels were very low against the limit.
4. Margin value = Emission level – Limit value

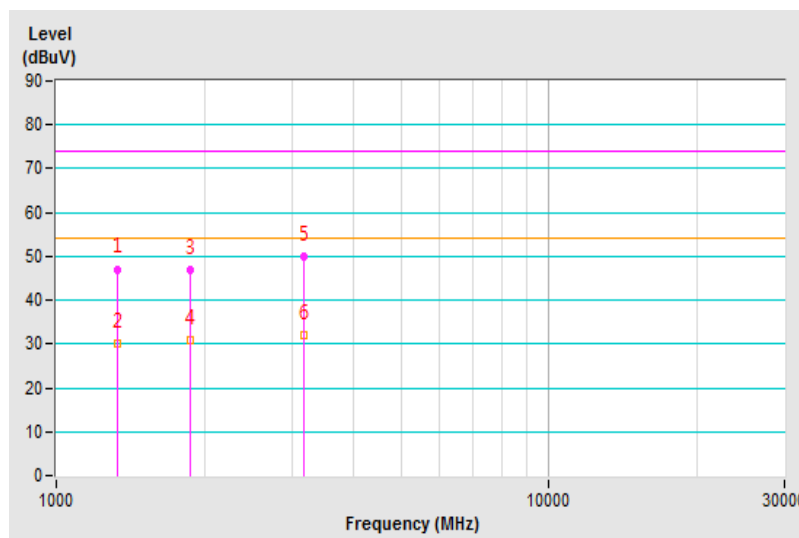

| | | | |
|------------------------|----------------|---|--------------------------------|
| Frequency Range | 1GHz ~ 12.5GHz | Detector Function & Resolution Bandwidth | Peak (PK) / Average (AV), 1MHz |
| Input Power | 120Vac, 60Hz | Environmental Conditions | 20°C, 65%RH |
| Tested by | Dalen Dai | | |
| Test Mode | Mode 1 | | |

| Antenna Polarity & Test Distance : Vertical at 3 m | | | | | | | | |
|--|-----------------|-------------------------|----------------|---------------|--------------------|----------------------|------------------|--------------------------|
| No | Frequency (MHz) | Emission Level (dBuV/m) | Limit (dBuV/m) | Margin (dB) | Antenna Height (m) | Table Angle (Degree) | Raw Value (dBuV) | Correction Factor (dB/m) |
| 1 | 1200.28 | 47.25 PK | 74.00 | -26.75 | 1.39 V | 176 | 51.74 | -4.49 |
| 2 | 1200.28 | 29.81 AV | 54.00 | -24.19 | 1.39 V | 176 | 34.30 | -4.49 |
| 3 | 1868.41 | 49.66 PK | 74.00 | -24.34 | 1.93 V | 159 | 51.96 | -2.30 |
| 4 | 1868.41 | 31.45 AV | 54.00 | -22.55 | 1.93 V | 159 | 33.75 | -2.30 |
| 5 | 2892.87 | 49.39 PK | 74.00 | -24.61 | 1.21 V | 179 | 47.42 | 1.97 |
| 6 | 2892.87 | 32.15 AV | 54.00 | -21.85 | 1.21 V | 179 | 30.18 | 1.97 |

Remarks:

1. Emission Level(dBuV/m) = Raw Value(dBuV) + Correction Factor(dB/m)
2. Correction Factor(dB/m) = Antenna Factor (dB/m) + Cable Factor (dB) – Pre-Amplifier Factor (dB)
3. The other emission levels were very low against the limit.
4. Margin value = Emission level – Limit value

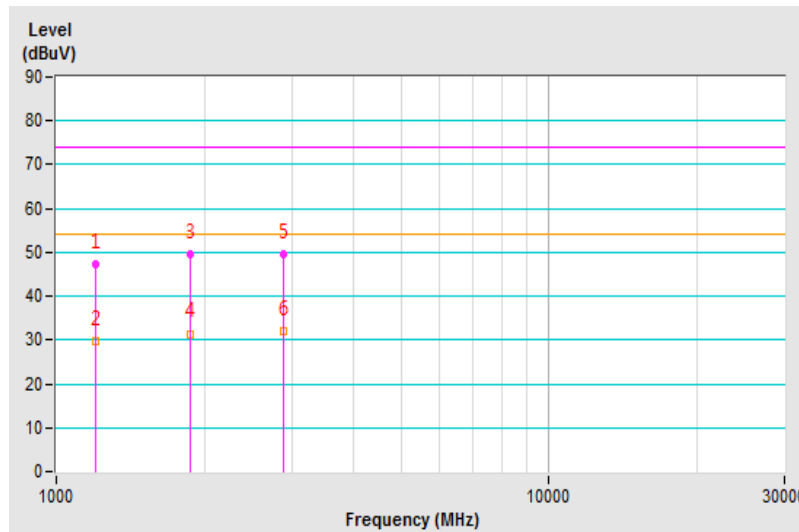

8 Pictures of Test Arrangements

8.1 Conducted Emissions at Mains Ports

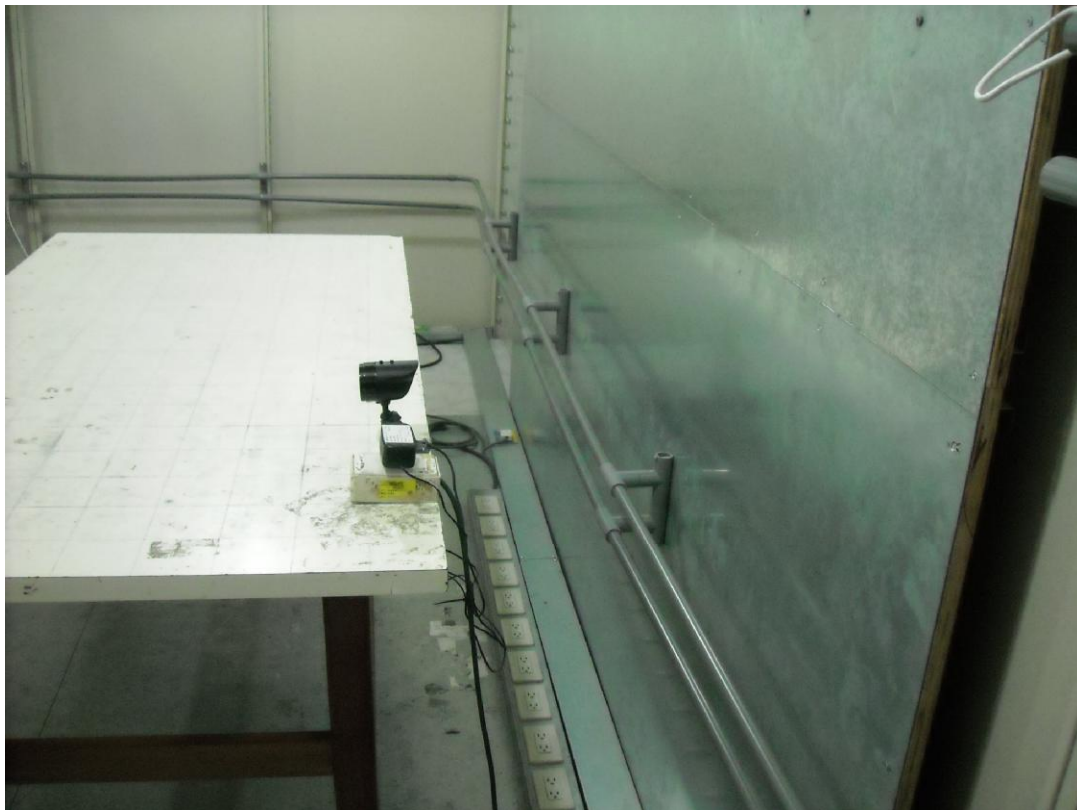

8.2 Radiated Emissions up to 1 GHz

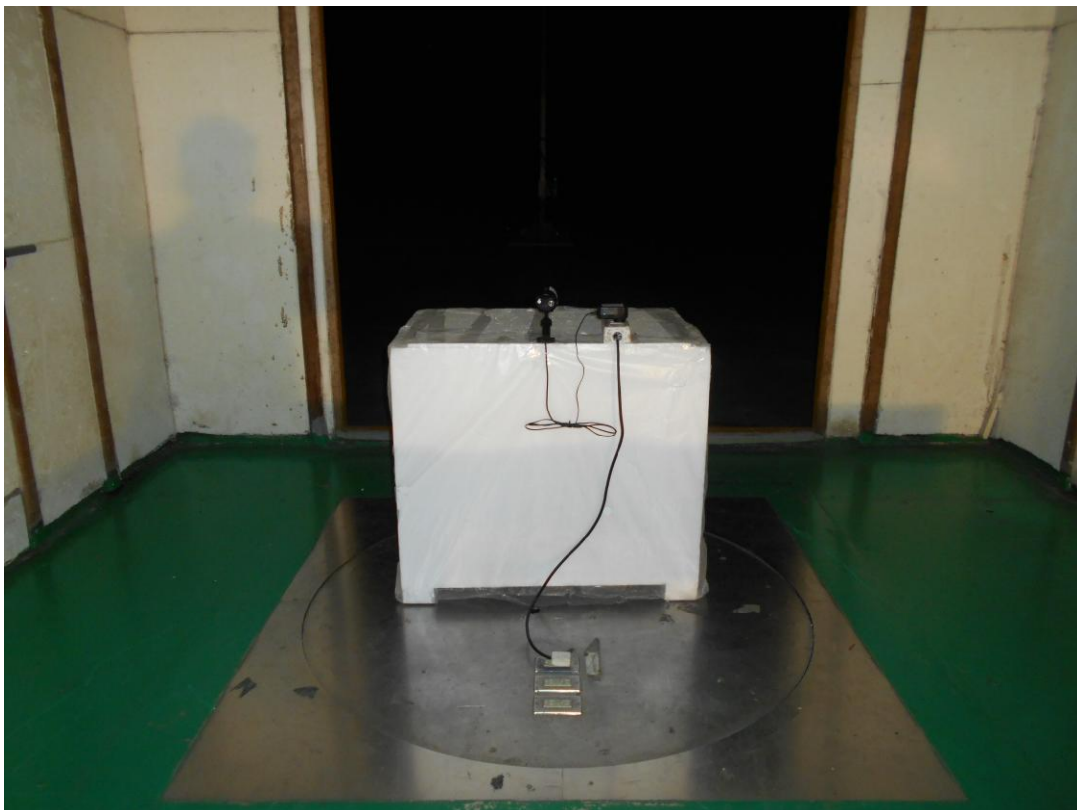
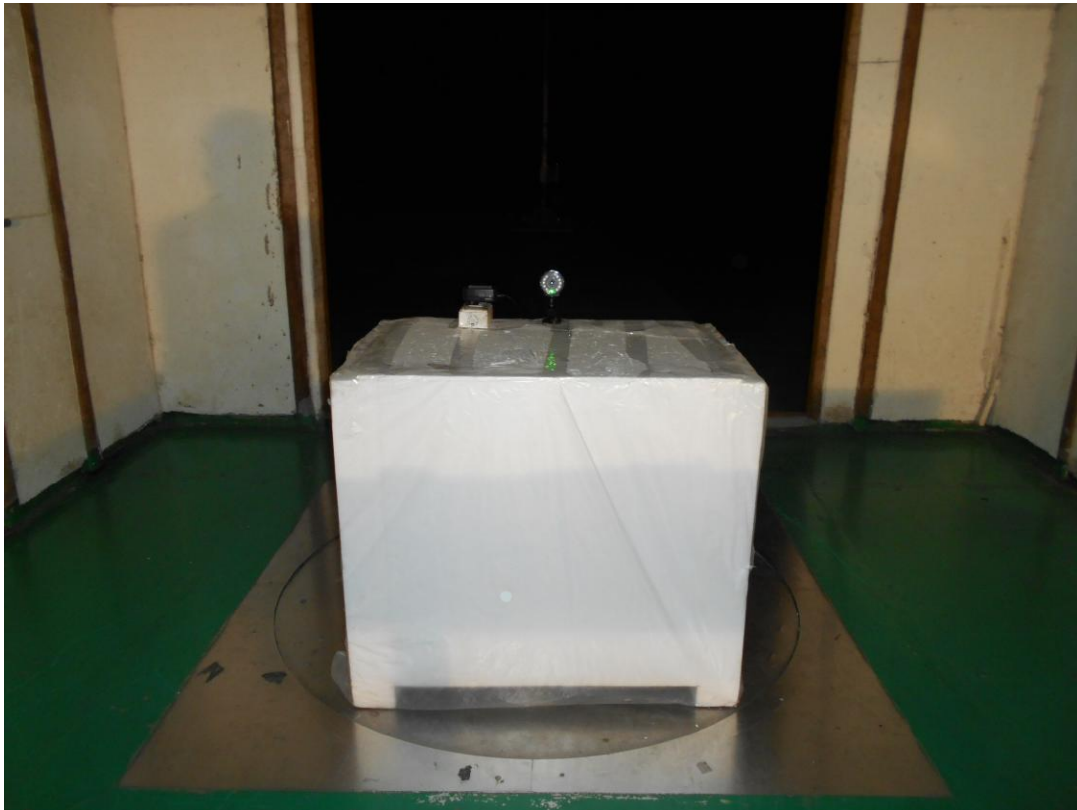

8.3 Radiated Emissions above 1 GHz

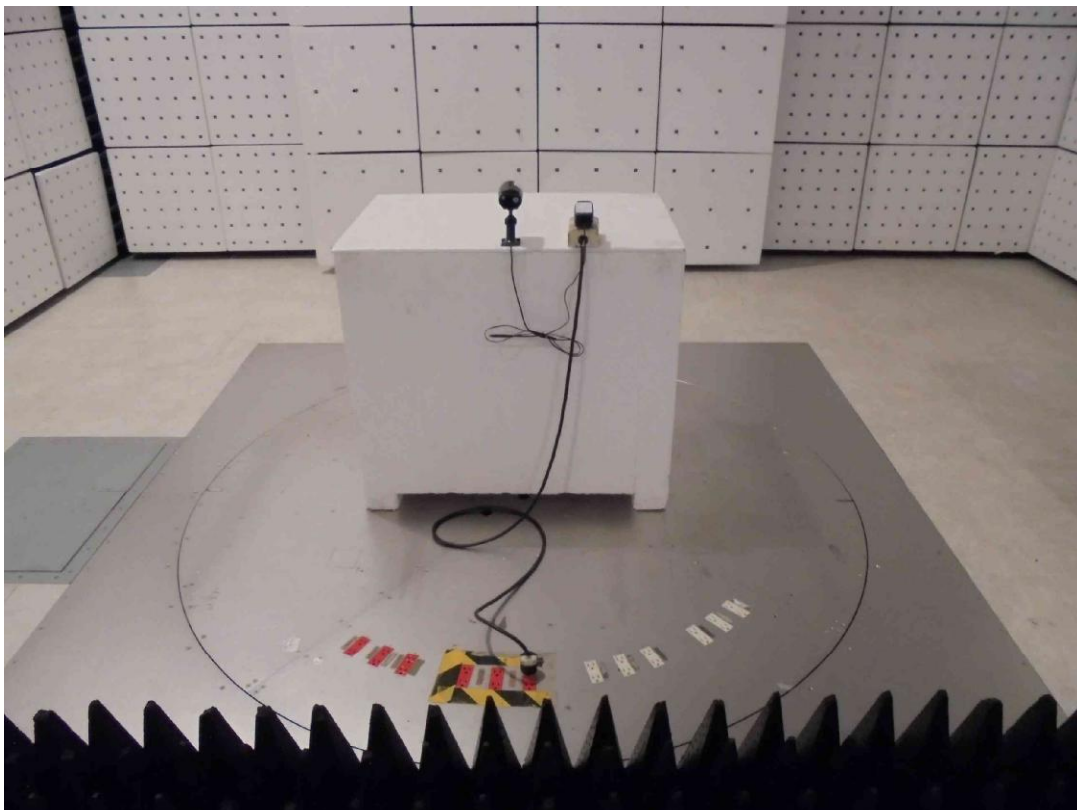
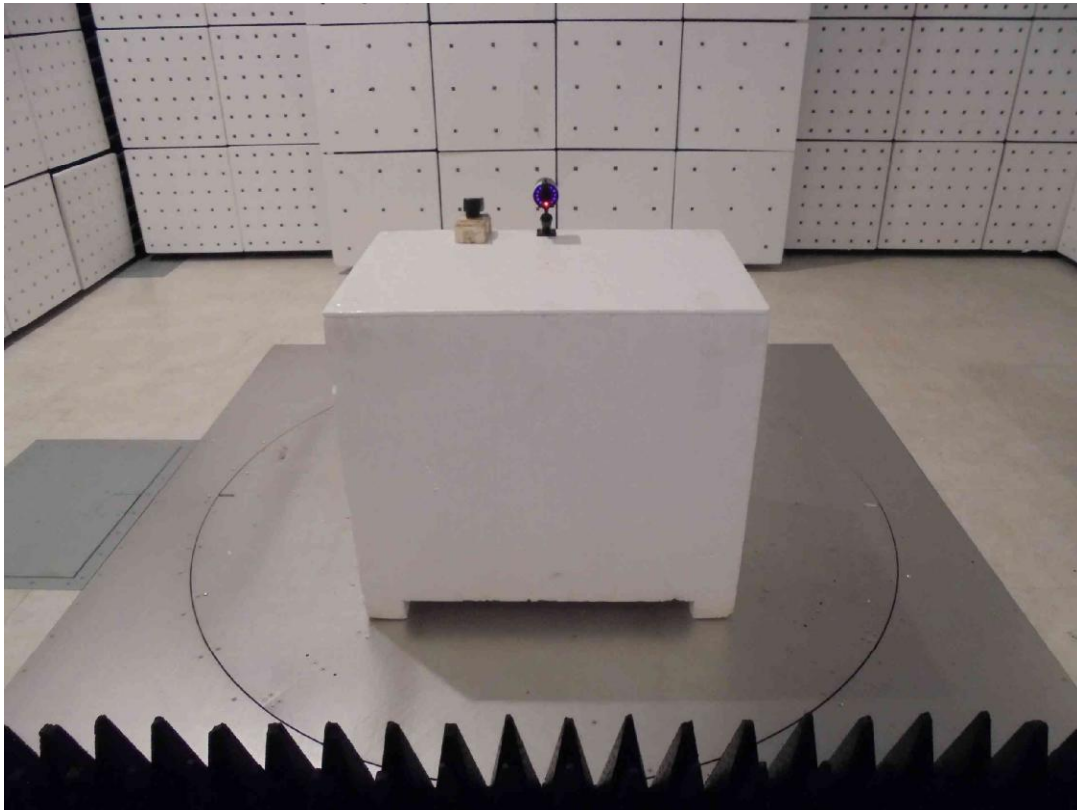

Appendix – Information on the Testing Laboratories

We, Bureau Veritas Consumer Products Services (H.K.) Ltd., Taoyuan Branch, were founded in 1988 to provide our best service in EMC, Radio, Telecom and Safety consultation. Our laboratories are accredited and approved according to ISO/IEC 17025.

If you have any comments, please feel free to contact us at the following:

Linko EMC/RF Lab

Tel: 886-2-26052180

Fax: 886-2-26051924

Hsin Chu EMC/RF/Telecom Lab

Tel: 886-3-6668565

Fax: 886-3-6668323

Hwa Ya EMC/RF/Safety Lab

Tel: 886-3-3183232

Fax: 886-3-3270892

Email: service.adt@tw.bureauveritas.com

Web Site: www.bureauveritas-adt.com

The address and road map of all our labs can be found in our web site also.

--- END ---