

CE Test Report

Product Name : Network Camera

Model No. : IB9387-HT, IB9387-EHT, IB9387-LPR, 5.0-H3B-BO3-IR

Applicant : VIVOTEK INC.

Address : 6F, No.192, Lien-Cheng Rd., Chung-Ho , New Taipei City,
235, Taiwan, R.O.C.

Date of Receipt : 2019/04/17

Issued Date : 2019/05/21

Report No. : 1940245R-ITCEP27V00

Report Version : V1.0

The test results relate only to the samples tested.

The test results shown in the test report are traceable to the national/international standard through the calibration of the equipment and evaluated measurement uncertainty herein.

This report must not be used to claim product endorsement by TAF or any agency of the government.

The test report shall not be reproduced without the written approval of DEKRA Testing and Certification Co., Ltd.

Test Report

Issued Date : 2019/05/21
Report No. : 1940245R-ITCEP27V00



Product Name : Network Camera
Applicant : VIVOTEK INC.
Address : 6F, No.192, Lien-Cheng Rd., Chung-Ho , New Taipei City,
235, Taiwan, R.O.C.
Manufacturer : VIVOTEK INC.
Model No. : IB9387-HT, IB9387-EHT, IB9387-LPR, 5.0-H3B-BO3-IR
EUT Rated Voltage : By PoE ; DC 12V
EUT Test Voltage : AC 230V / 50Hz, By PoE
Trade Name : VIVOTEK
Applicable Standard : EN 50121-1: 2017
EN 50121-4: 2016
EN 61000-6-4: 2007+A1: 2011
Test Result : Complied
Performed Location : DEKRA Testing and Certification Co., Ltd.
Linkou Laboratory
No. 5-22, Ruishukeng
Linkou District, New Taipei City, 24451, Taiwan
TEL:+866-2-8601-3788 / FAX:+886-2-8601-3789

Documented By : Genie Chang
(Senior Adm. Specialist / Genie Chang)

Reviewed By : Wright Tsai
(Engineer / Wright Tsai)

Approved By : Vincent Lin
(Director / Vincent Lin)

TABLE OF CONTENTS

Description	Page
1. General Information	5
1.1. EUT Description.....	5
1.2. Mode of Operation	6
1.3. Tested System Details	7
1.4. Configuration of Tested System	8
1.5. EUT Exercise Software.....	10
2. Technical Test	11
2.1. Summary of Test Result.....	11
2.2. List of Test Equipment	12
2.3. Measurement Uncertainty	14
2.4. Test Environment	16
3. Conducted Emissions (Telecommunication Ports).....	17
3.1. Test Specification	26
3.2. Test Setup.....	26
3.3. Limit.....	26
3.4. Test Procedure	27
3.5. Deviation from Test Standard.....	27
3.6. Test Result	28
3.7. Test Photograph	40
4. Radiated Emission.....	41
4.1. Test Specification	42
4.2. Test Setup.....	42
4.3. Limit.....	43
4.4. Test Procedure	44
4.5. Deviation from Test Standard.....	44
4.6. Test Result	45
4.7. Test Photograph	53
5. Electrostatic Discharge	56
5.1. Test Specification	56
5.2. Test Setup.....	56
5.3. Limit.....	56
5.4. Test Procedure	57
5.5. Deviation from Test Standard.....	57
5.6. Test Result	58
5.7. Test Photograph	60
5.8. EUT to dot photo for ESD test	61
6. Radiated Susceptibility	64
6.1. Test Specification	64
6.2. Test Setup.....	64
6.3. Limit.....	64
6.4. Test Procedure	65

6.5.	Deviation from Test Standard.....	65
6.6.	Test Result.....	66
6.7.	Test Photograph	70
7.	Electrical Fast Transient/Burst	76
7.1.	Test Specification.....	76
7.2.	Test Setup.....	76
7.3.	Limit.....	76
7.4.	Test Procedure	77
7.5.	Deviation from Test Standard.....	77
7.6.	Test Result.....	78
7.7.	Test Photograph	80
8.	Surge	82
8.1.	Test Specification.....	82
8.2.	Test Setup.....	82
8.3.	Limit.....	82
8.4.	Test Procedure	83
8.5.	Deviation from Test Standard.....	83
8.6.	Test Result.....	84
8.7.	Test Photograph	86
9.	Conducted Susceptibility	87
9.1.	Test Specification.....	87
9.2.	Test Setup.....	87
9.3.	Limit.....	88
9.4.	Test Procedure	88
9.5.	Deviation from Test Standard.....	88
9.6.	Test Result.....	89
9.7.	Test Photograph	91
10.	Power Frequency Magnetic Field	93
10.1.	Test Specification.....	93
10.2.	Test Setup.....	93
10.3.	Limit.....	93
10.4.	Test Procedure	94
10.5.	Deviation from Test Standard.....	94
10.6.	Test Result.....	95
10.7.	Test Photograph	97
11.	Attachment	98
	EUT Photograph.....	98

1. General Information

1.1. EUT Description

Product Name	Network Camera
Trade Name	VIVOTEK
Model No.	IB9387-HT, IB9387-EHT, IB9387-LPR, 5.0-H3B-BO3-IR

Note: The different of each model is shown as below

Model Number	Different
IB9387-HT	Non wide temperature
IB9387-LPR	
5.0-H3B-BO3-IR	
IB9387-EHT	Wide temperature
Note: IB9387-LPR Have SD card	

1.2. Mode of Operation

DEKRA has verified the construction and function in typical operation. All the test modes were carried out with the EUT in normal operation, which was shown in this test report and defined as:

Pre-Test Mode	
Mode 1: IB9387-EHT, Adapter	
Mode 2: IB9387-EHT, PoE	
Final Test Mode	
Emission	Mode 1: IB9387-EHT, Adapter Mode 2: IB9387-EHT, PoE
Immunity	Mode 1: IB9387-EHT, Adapter Mode 2: IB9387-EHT, PoE

1.3. Tested System Details

The types for all equipments, plus descriptions of all cables used in the tested system (including inserted cards) are:

Test Mode		Mode 1			
Product		Manufacturer	Model No.	Serial No.	Power Cord
1	Notebook PC	DELL	Latitude 5580	GDZN7H2	Non-shielded, 0.8m
2	Micro SD Card 1GB	SanDisk	N/A	0734502841D85	N/A
3	Microphone & Earphone	RONEVER	MOE240	N/A	N/A

Test Mode		Mode 2			
Product		Manufacturer	Model No.	Serial No.	Power Cord
1	Notebook PC	DELL	Latitude 5580	GDZN7H2	Non-shielded, 0.8m
2	PoE	N/A	N/A	N/A	Non-shielded, 1.8m
3	Micro SD Card 1GB	SanDisk	N/A	0734502841D85	N/A
4	Microphone & Earphone	RONEVER	MOE240	N/A	N/A

1.4. Configuration of Tested System

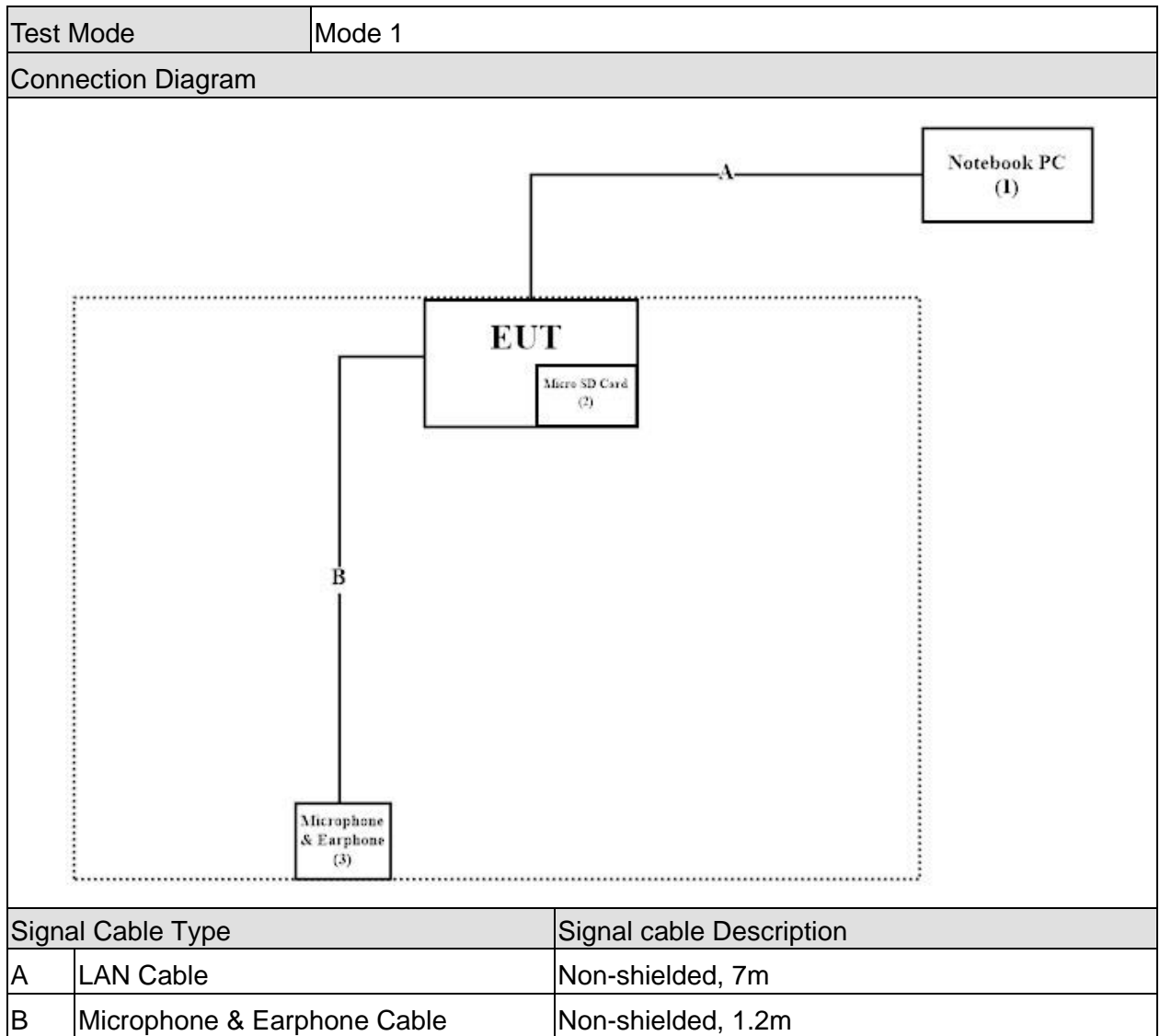

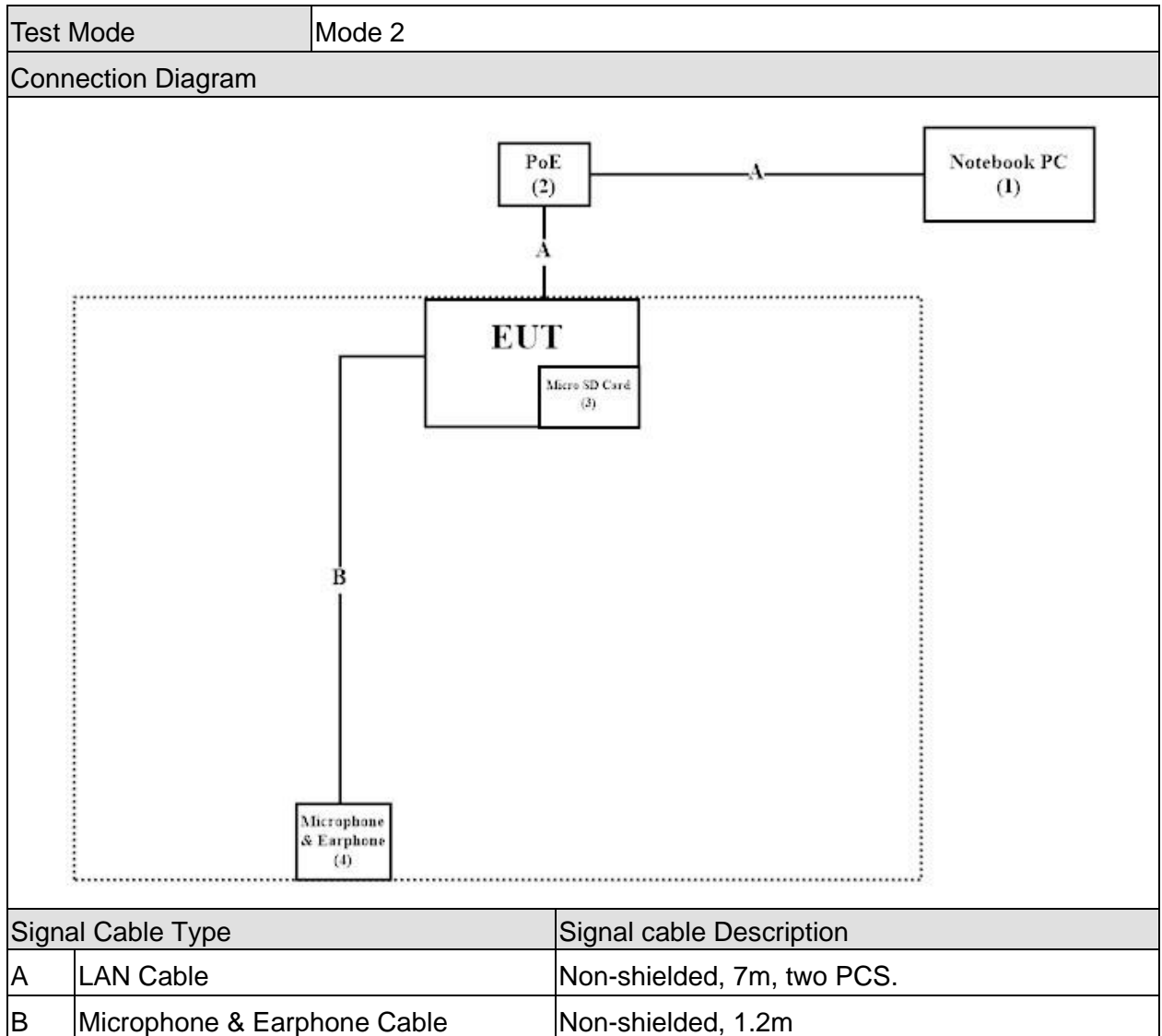

1.5. EUT Exercise Software

1	Setup the EUT and simulators as shown on 1.4.
2	Turn on the power of all equipment.
3	The EUT will start to operate and display the video figure from the signal source.
4	The EUT will display “video figure” on monitor.
5	SD card works while the EUT is recording.
6	Repeat the above procedure (3) to (5).

2. Technical Test

2.1. Summary of Test Result

- No deviations from the test standards
 Deviations from the test standards as below description:

Emission			
Performed Item	Normative References	Test Performed	Deviation
Power Line Conducted Emission	EN 61000-6-4:2007+A1:2011 CISPR 16-2-1:2003+A1:2005 CISPR 16-1-2:2003/A2:2006	Yes	No
Impedance Stabilization Network (ISN)	EN 61000-6-4:2007+A1:2011 CISPR 22	Yes	No
Radiated Emission	EN 61000-6-4:2007+A1:2011 CISPR 16-2-3:2006	Yes	No

Immunity			
Performed Item	Normative References	Test Performed	Deviation
Electrostatic Discharge	IEC 61000-4-2 Ed. 2.0: 2008	Yes	No
Radio-frequency electromagnetic field. (Radiated susceptibility)	IEC 61000-4-3 Ed. 3.2: 2010	Yes	No
Electrical fast transient/burst	IEC 61000-4-4 Ed. 3.0: 2012	Yes	No
Surge	IEC 61000-4-5 Ed. 3.1: 2014+A1: 2017	Yes	No
Radio-frequency common mode (Conducted susceptibility)	IEC 61000-4-6 Ed. 4.0: 2013	Yes	No
Power frequency magnetic field	IEC 61000-4-8 Ed. 2.0: 2009	Yes	No

2.2. List of Test Equipment

Conducted Emission / SR8

Instrument	Manufacturer	Type No.	Serial No	Cal. Date
EMI Test Receiver	R&S	ESCS 30	100369	2018/11/19
LISN	R&S	ENV216	100097	2019/02/18
LISN	R&S	ESH3-Z5	836679/017	2019/02/18
Coaxial Cable	DEKRA	RG 400	LC018-RG	2018/06/21

Impedance Stabilization Network / SR8

Instrument	Manufacturer	Type No.	Serial No	Cal. Date
EMI Test Receiver	R&S	ESCS 30	100369	2018/11/19
LISN	R&S	ENV216	100097	2019/02/18
LISN	R&S	ESH3-Z5	836679/017	2019/02/18
Coaxial Cable	DEKRA	RG 400	LC018-RG	2018/06/21
Capacitive Voltage Probe	Schaffner	CVP2200A	18331	2018/12/03
RF Current Probe	FCC	F-65	198	2018/12/13
BALANCED TELECOM ISN	FCC	FCC-TLISN-T2-02	20316	2018/09/14
Impedance Stabilization Network	Teseq	ISN T800	42815	2018/07/12

Radiated Emission / Site7

Instrument	Manufacturer	Type No.	Serial No	Cal. Date
Broadband Antenna	Schwarzbeck	VULB 9168	0852	2019/02/02
EMI Test Receiver	R&S	ESCI	100649	2018/07/20
Coaxial Cable	DEKRA	RG 214	LC007-RG	2018/06/18
Pre-Amplifier	DEKRA	AP/0100A	CHM/1009094	2018/06/18
Site7 NSA	DEKRA	N/A	N/A	2018/06/18

Radiated Emission / CB7

Instrument	Manufacturer	Type No.	Serial No	Cal. Date
EMI Test Receiver	R&S	ESU26	100433	2018/11/13
Horn Antenna	ETS-Lindgren	3117	00202723	2018/08/08
Horn Antenna	SCHWARZBECK	9120D	576	2018/12/18
Pre-Amplifier	EMCI	EMC051845SE	980359	2018/10/24
CB7 VSWR	DEKRA	N/A	N/A	2018/06/25

Electrostatic Discharge / SR6

Instrument	Manufacturer	Type No.	Serial No	Cal. Date
ESD Simulator System	Noiseken	ESS-B3011	ESS1233479	2018/05/16
ESD GUN	Noiseken	GT-30R	ESS1233499	2018/05/16
Horizontal Coupling Plane(HCP)	QuieTek	HCP AL50	N/A	N/A
Vertical Coupling Plane(VCP)	QuieTek	VCP AL50	N/A	N/A

Radiated susceptibility / CB9

Instrument	Manufacturer	Type No.	Serial No	Cal. Date
Signal Generator	Keysight	N5171B	MY53051650	2019/03/05
Power Sensor	Keysight	N1912A	MY55480006	2019/03/06
Stacked double Log.-Per.-Broadband Antenna	SCHWARZBECK	STLP 9129	9129 011	N/A
Power Amplifier	MILMEGA	80RF1000-300	1071481	N/A
Power Amplifier	MILMEGA	AS0860B-50/50	1071482	N/A
uniform field calibration	Dekra	N/A	N/A	2018/06/15

Electrical fast transient/burst / SR6

Instrument	Manufacturer	Type No.	Serial No	Cal. Date
EMS TEST System	TESEQ	NSG 3060	1685	2018/09/02

Surge / SR6

Instrument	Manufacturer	Type No.	Serial No	Cal. Date
EMS TEST System	TESEQ	NSG 3060	1685	2018/09/02

Conducted susceptibility / SR6

Instrument	Manufacturer	Type No.	Serial No	Cal. Date
TESEQ RF-Generator	TESEQ	NSG 4070B-30	37490	2018/05/29

Power frequency magnetic field / SR3

Instrument	Manufacturer	Type No.	Serial No	Cal. Date
45kVA Power Source	TESEQ	NSG 1007-45	1847A00294	2018/12/19
Magnetic Loop Coil	TESEQ	INA 703	2007	2018/08/02

2.3. Measurement Uncertainty

Conducted Emission

The measurement uncertainty is evaluated as ± 3.44 dB.

Impedance Stabilization Network

The measurement uncertainty is evaluated as ± 3.88 dB.

Radiated Emission

The measurement uncertainty is evaluated as ± 4.22 dB.

Radiated Emission Above 1GHz

The measurement uncertainty is evaluated as ± 5.08 dB.

Electrostatic Discharge

As what is concluded in the document from Note2 of clause 5.4.6.2 of ISO/IEC 17025, the requirements for measurement uncertainty in ESD testing are deemed to have been satisfied, and the testing is reported in accordance with the relevant ESD standards. The immunity test signal from the ESD system meet the required specifications in IEC 61000-4-2 through the calibration report with the calibrated uncertainty for the waveform of voltage, current and timing as being 1.5 %, 4.6% and 6.7%.

Radiated susceptibility

As what is concluded in the document from Note2 of clause 5.4.6.2 of ISO/IEC 17025, the requirements for measurement uncertainty in RS testing are deemed to have been satisfied, and the testing is reported in accordance with the relevant RS standards. The immunity test signal from the RS system meet the required specifications in IEC 61000-4-3 through the calibration for the uniform field strength and monitoring for the test level with the uncertainty evaluation report for the electrical field strength as being 3.57 dB.

Electrical fast transient/burst

As what is concluded in the document from Note2 of clause 5.4.6.2 of ISO/IEC 17025, the requirements for measurement uncertainty in EFT/Burst testing are deemed to have been satisfied, and the testing is reported in accordance with the relevant EFT/Burst standards. The immunity test signal from the EFT/Burst system meet the required specifications in IEC 61000-4-4 through the calibration report with the calibrated uncertainty for the waveform of voltage, frequency and timing as being 6.3 %,5.1% and 5.3%.

Surge

As what is concluded in the document from Note2 of clause 5.4.6.2 of ISO/IEC 17025, the requirements for measurement uncertainty in Surge testing are deemed to have been satisfied, and the testing is reported in accordance with the relevant Surge standards. The immunity test signal from the Surge system meet the required specifications in IEC 61000-4-5 through the calibration report with the calibrated uncertainty for the waveform of voltage, current and timing as being 5.6 %, 7.7% and 4.6%.

Conducted susceptibility

As what is concluded in the document from Note2 of clause 5.4.6.2 of ISO/IEC 17025, the requirements for measurement uncertainty in CS testing are deemed to have been satisfied, and the testing is reported in accordance with the relevant CS standards. The immunity test signal from the CS system meet the required specifications in IEC 61000-4-6 through the calibration for unmodulated signal and monitoring for the test level with the uncertainty evaluation report for the injected modulated signal level through CDN and EM Clamp/Direct Injection as being 2.15 dB and 3.3 dB.

Power frequency magnetic field

As what is concluded in the document from Note2 of clause 5.4.6.2 of ISO/IEC 17025, the requirements for measurement uncertainty in PFM testing are deemed to have been satisfied, and the testing is reported in accordance with the relevant PFM standards. The immunity test signal from the PFM system meet the required specifications in IEC 61000-4-8 through the calibration report with the calibrated uncertainty for the Gauss Meter to verify the output level of magnetic field strength as being 2.0 %.

2.4. Test Environment

Performed Item	Items	Required	Actual
Conducted Emission	Temperature (°C)	15-35	24.5
	Humidity (%RH)	25-75	53
	Barometric pressure (mbar)	860-1060	950-1000
Impedance Stabilization Network	Temperature (°C)	15-35	24.5
	Humidity (%RH)	25-75	53
	Barometric pressure (mbar)	860-1060	950-1000
Radiated Emission	Temperature (°C)	15-35	23.8
	Humidity (%RH)	25-75	75
	Barometric pressure (mbar)	860-1060	950-1000
Electrostatic Discharge	Temperature (°C)	15-35	20
	Humidity (%RH)	30-60	50
	Barometric pressure (mbar)	860-1060	950-1000
Radiated susceptibility	Temperature (°C)	15-35	18
	Humidity (%RH)	25-75	53
	Barometric pressure (mbar)	860-1060	950-1000
Electrical fast transient/burst	Temperature (°C)	15-35	20
	Humidity (%RH)	25-75	50
	Barometric pressure (mbar)	860-1060	950-1000
Surge	Temperature (°C)	15-35	20
	Humidity (%RH)	10-75	50
	Barometric pressure (mbar)	860-1060	950-1000
Conducted susceptibility	Temperature (°C)	15-35	20
	Humidity (%RH)	25-75	50
	Barometric pressure (mbar)	860-1060	950-1000
Power frequency magnetic field	Temperature (°C)	15-35	20
	Humidity (%RH)	25-75	51
	Barometric pressure (mbar)	860-1060	950-1000

3. Conducted Emission (Main Terminals)

3.1. Test Specification

According to EN 50121-4 clause 5 and EN 61000-6-4 Table 1

3.2. Test Setup

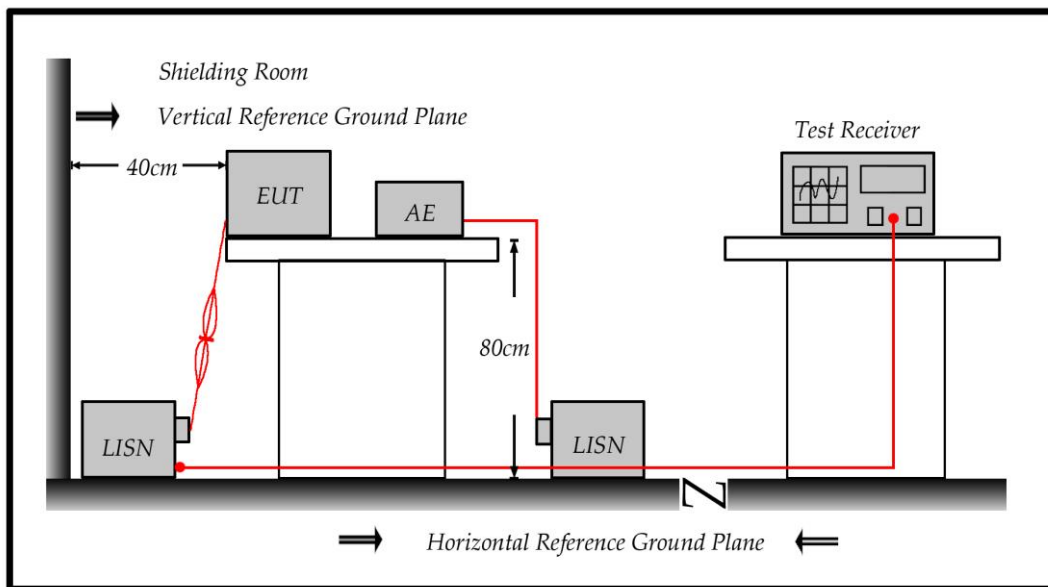

3.3. Limit

Limits		
Frequency MHz	QP dBuV	AV dBiV
0.15 - 0.50	79	66
0.50-5.0	73	60
5.0 - 30	73	60

Remarks: In the above table, the tighter limit applies at the band edges.

3.4. Test Procedure

According to CISPR 16-2-1 clause 7.4.1 and CISPR 16-1-2 clause 4.3 :

The EUT and simulators are connected to the main power through a line impedance stabilization network (L.I.S.N.). This provides a 50 ohm /50uH coupling impedance for the measuring equipment. The peripheral devices are also connected to the main power through a LISN that provides a 50ohm/50uH coupling impedance with 50ohm termination.

(Please refers to the block diagram of the test setup and photographs.)

Both sides of D.C. line are checked for maximum conducted interference. In order to find the maximum emission, the relative positions of equipment and all of the interface cables must be changed on conducted measurement.

Conducted emissions were invested over the frequency range from 0.15MHz to 30MHz using a receiver bandwidth of 9kHz.

3.5. Deviation from Test Standard

No deviation.

3.6. Test Result

Site : SR8	Time : 2019/04/09 - 13:20
Limit : CISPR_A_00M_QP	Margin : 13
EUT : Network Camera	Probe : ENV216_L1_1068 - Line1
Power : AC 230V/50Hz	Note : Mode 1

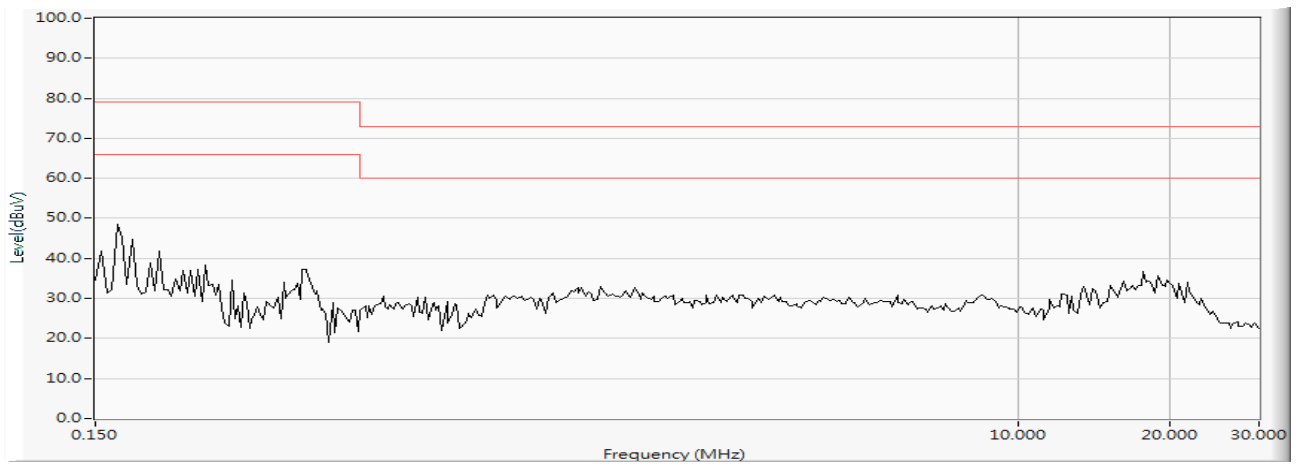

Site : SR8	Time : 2019/04/09 - 13:21
Limit : CISPR_A_00M_QP	Margin : 0
EUT : Network Camera	Probe : ENV216_L1_1068 - Line1
Power : AC 230V/50Hz	Note : Mode 1

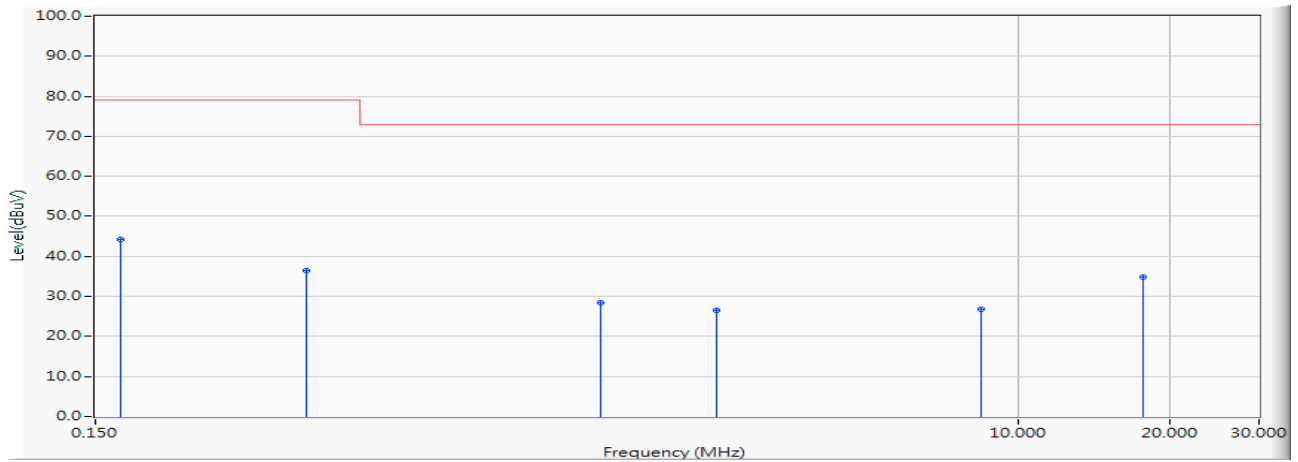

		Frequency (MHz)	Correct Factor (dB)	Reading Level (dBuV)	Measure Level (dBuV)	Margin (dB)	Limit (dBuV)	Detector Type
1	*	0.168	9.657	34.520	44.177	-34.823	79.000	QUASPEAK
2		0.392	9.666	26.680	36.346	-42.654	79.000	QUASPEAK
3		1.498	9.717	18.820	28.537	-44.463	73.000	QUASPEAK
4		2.545	9.758	16.780	26.538	-46.462	73.000	QUASPEAK
5		8.459	9.942	16.940	26.882	-46.118	73.000	QUASPEAK
6		17.693	10.121	24.840	34.961	-38.039	73.000	QUASPEAK

Note:

1. All Reading Levels are Quasi-Peak and average value.
2. " * ", means this data is the worst emission level.
3. Measurement Level = Reading Level + Correct Factor(Probe+Cable-Amp).

Site : SR8	Time : 2019/04/09 - 13:21
Limit : CISPR_A_00M_AV	Margin : 0
EUT : Network Camera	Probe : ENV216_L1_1068 - Line1
Power : AC 230V/50Hz	Note : Mode 1

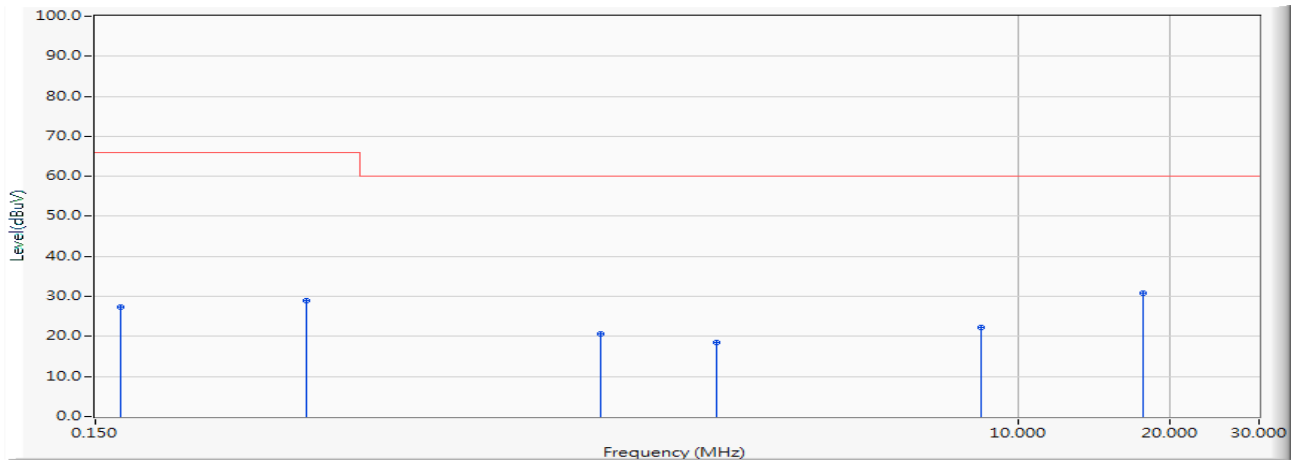

		Frequency (MHz)	Correct Factor (dB)	Reading Level (dBuV)	Measure Level (dBuV)	Margin (dB)	Limit (dBuV)	Detector Type
1		0.168	9.657	17.580	27.237	-38.763	66.000	AVERAGE
2		0.392	9.666	19.200	28.866	-37.134	66.000	AVERAGE
3		1.498	9.717	10.820	20.537	-39.463	60.000	AVERAGE
4		2.545	9.758	8.640	18.398	-41.602	60.000	AVERAGE
5		8.459	9.942	12.440	22.382	-37.618	60.000	AVERAGE
6	*	17.693	10.121	20.820	30.941	-29.059	60.000	AVERAGE

Note:

1. All Reading Levels are Quasi-Peak and average value.
2. " * ", means this data is the worst emission level.
3. Measurement Level = Reading Level + Correct Factor(Probe+Cable-Amp).

Site : SR8	Time : 2019/04/09 - 13:22
Limit : CISPR_A_00M_QP	Margin : 10
EUT : Network Camera	Probe : ENV216_N_1068 - Line2
Power : AC 230V/50Hz	Note : Mode 1

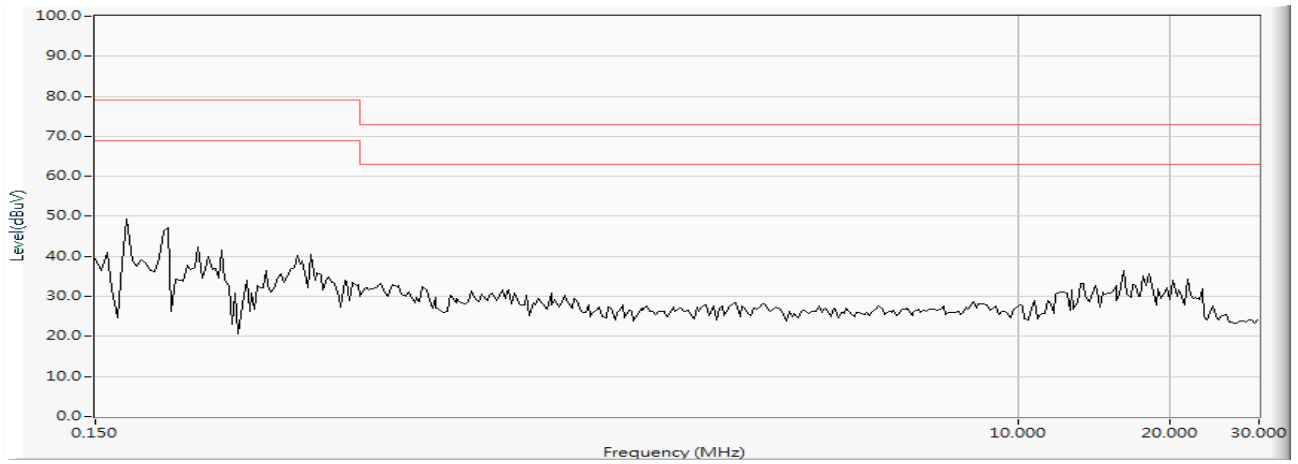

Site : SR8	Time : 2019/04/09 - 13:23
Limit : CISPR_A_00M_QP	Margin : 0
EUT : Network Camera	Probe : ENV216_N_1068 - Line2
Power : AC 230V/50Hz	Note : Mode 1

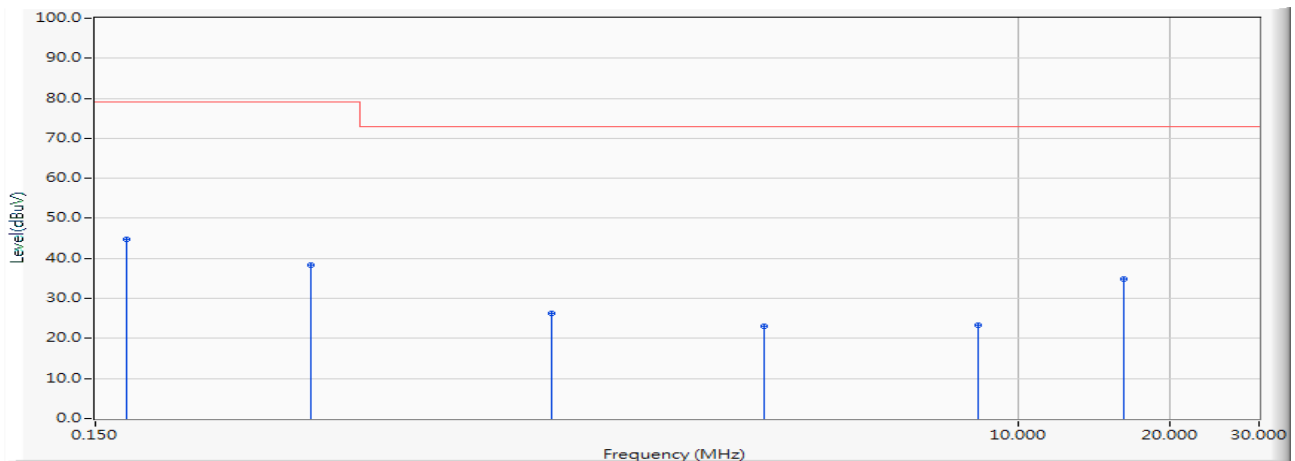

		Frequency (MHz)	Correct Factor (dB)	Reading Level (dBuV)	Measure Level (dBuV)	Margin (dB)	Limit (dBuV)	Detector Type
1	*	0.173	9.692	35.200	44.892	-34.108	79.000	QUASIPeAK
2		0.400	9.696	28.620	38.316	-40.684	79.000	QUASIPeAK
3		1.197	9.739	16.440	26.179	-46.821	73.000	QUASIPeAK
4		3.162	9.822	13.280	23.102	-49.898	73.000	QUASIPeAK
5		8.349	10.000	13.340	23.340	-49.660	73.000	QUASIPeAK
6		16.228	10.231	24.680	34.911	-38.089	73.000	QUASIPeAK

Note:

1. All Reading Levels are Quasi-Peak and average value.
2. " * ", means this data is the worst emission level.
3. Measurement Level = Reading Level + Correct Factor(Probe+Cable-Amp).

Site : SR8	Time : 2019/04/09 - 13:23
Limit : CISPR_A_00M_AV	Margin : 0
EUT : Network Camera	Probe : ENV216_N_1068 - Line2
Power : AC 230V/50Hz	Note : Mode 1

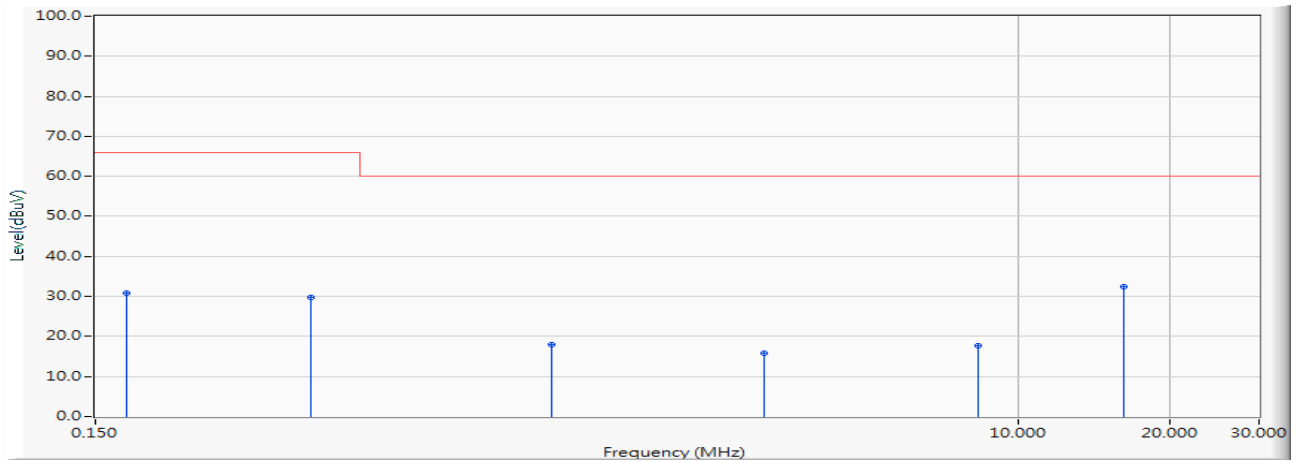

		Frequency (MHz)	Correct Factor (dB)	Reading Level (dBuV)	Measure Level (dBuV)	Margin (dB)	Limit (dBuV)	Detector Type
1		0.173	9.692	21.180	30.872	-35.128	66.000	AVERAGE
2		0.400	9.696	20.020	29.716	-36.284	66.000	AVERAGE
3		1.197	9.739	8.240	17.979	-42.021	60.000	AVERAGE
4		3.162	9.822	5.980	15.802	-44.198	60.000	AVERAGE
5		8.349	10.000	7.660	17.660	-42.340	60.000	AVERAGE
6	*	16.228	10.231	22.220	32.451	-27.549	60.000	AVERAGE

Note:

1. All Reading Levels are Quasi-Peak and average value.
2. " * ", means this data is the worst emission level.
3. Measurement Level = Reading Level + Correct Factor(Probe+Cable-Amp).

3.7. Test Photograph

Test Mode : Mode 1: IB9387-EHT, Adapter

Description : Front View of Conducted Test



Test Mode : Mode 1: IB9387-EHT, Adapter

Description : Back View of Conducted Test



4. Conducted Emissions (Telecommunication Ports)

4.1. Test Specification

According to EN 50121-4 clause 5 and EN 61000-6-4 Table 1

4.2. Test Setup

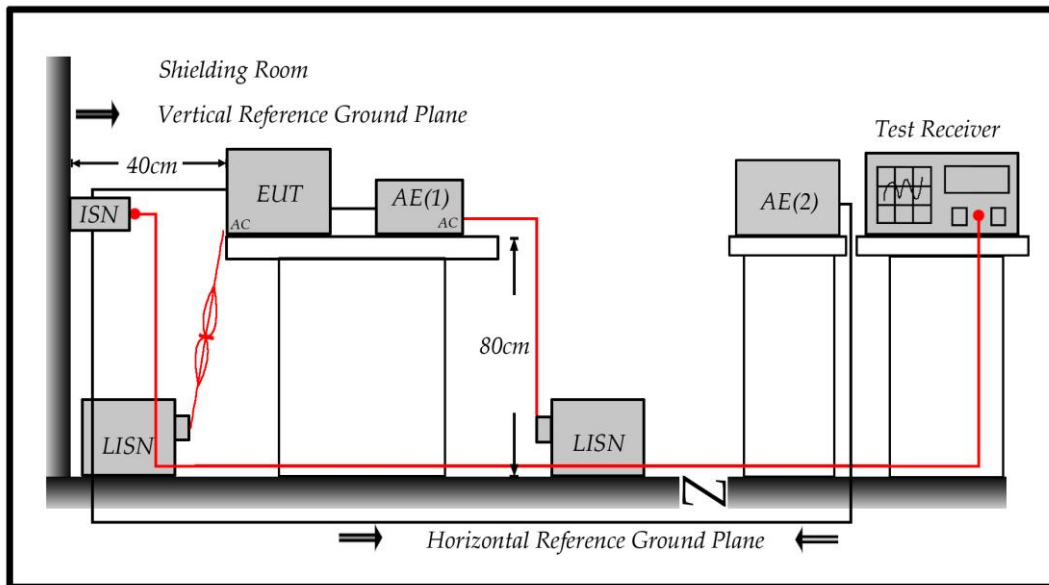

4.3. Limit

Frequency (MHz)	Voltage Limits		Current Limits	
	QP (dBuV)	AV (dBuV)	QP (dBuV)	AV (dBuV)
0.15 - 0.50	97 – 87	84 – 74	53 – 43	40 – 30
0.50 - 30	87	74	43	30

Remarks:

The limit decreases linearly with the logarithm of the frequency in the range 0.15 MHz~0.50 MHz.

4.4. Test Procedure

Telecommunication Port:

The mains voltage shall be supplied to the EUT via the LISN when the measurement of telecommunication port is performed. The common mode disturbances at the telecommunication port shall be connected to the ISN, which is 150 ohm impedance.

Both alternative cables are tested related to the LCL requested. The measurement range is from 150kHz to 30MHz. The bandwidth of measurement is set to 9kHz.

The 75dB LCL ISN is used for cat. 6 cable, the 65dB LCL ISN is used for cat. 5 cable, 55dB LCL ISN is used for cat. 3.

4.5. Deviation from Test Standard

No deviation.

4.6. Test Result

Site : SR8	Time : 2019/04/09 - 13:05
Limit : ISN_Voltage_A_00M_QP	Margin : 13
EUT : Network Camera	Probe : TESEQ_T8_42815 - Line1
Power : AC 230V/50Hz	Note :Mode 1,ISN 10M

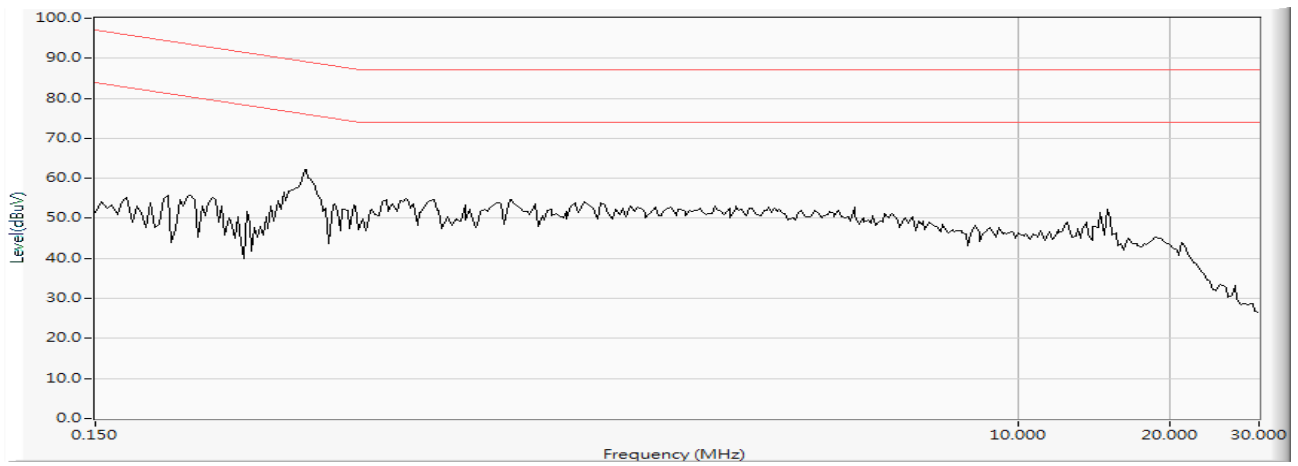

Site : SR8	Time : 2019/04/09 - 13:07
Limit : ISN_Voltage_A_00M_QP	Margin : 0
EUT : Network Camera	Probe : TESEQ_T8_42815 - Line1
Power : AC 230V/50Hz	Note :Mode 1, ISN 10M

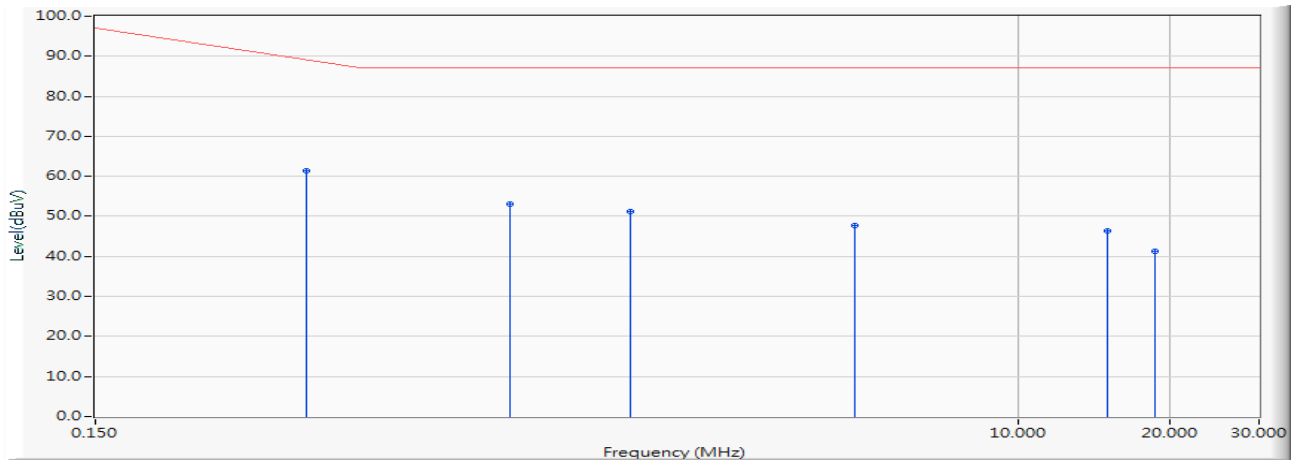

		Frequency (MHz)	Correct Factor (dB)	Reading Level (dBuV)	Measure Level (dBuV)	Margin (dB)	Limit (dBuV)	Detector Type
1	*	0.392	10.054	51.220	61.274	-28.812	90.086	QUASPEAK
2		0.994	9.930	43.080	53.010	-33.990	87.000	QUASPEAK
3		1.716	9.910	41.280	51.190	-35.810	87.000	QUASPEAK
4		4.752	9.908	37.820	47.728	-39.272	87.000	QUASPEAK
5		15.041	10.163	36.240	46.403	-40.597	87.000	QUASPEAK
6		18.638	10.248	31.020	41.268	-45.732	87.000	QUASPEAK

Note:

1. All Reading Levels are Quasi-Peak and average value.
2. " * ", means this data is the worst emission level.
3. Measurement Level = Reading Level + Correct Factor(Probe+Cable-Amp).

Site : SR8	Time : 2019/04/09 - 13:07
Limit : ISN_Voltage_A_00M_AV	Margin : 0
EUT : Network Camera	Probe : TESEQ_T8_42815 - Line1
Power : AC 230V/50Hz	Note :Mode 1, ISN 10M

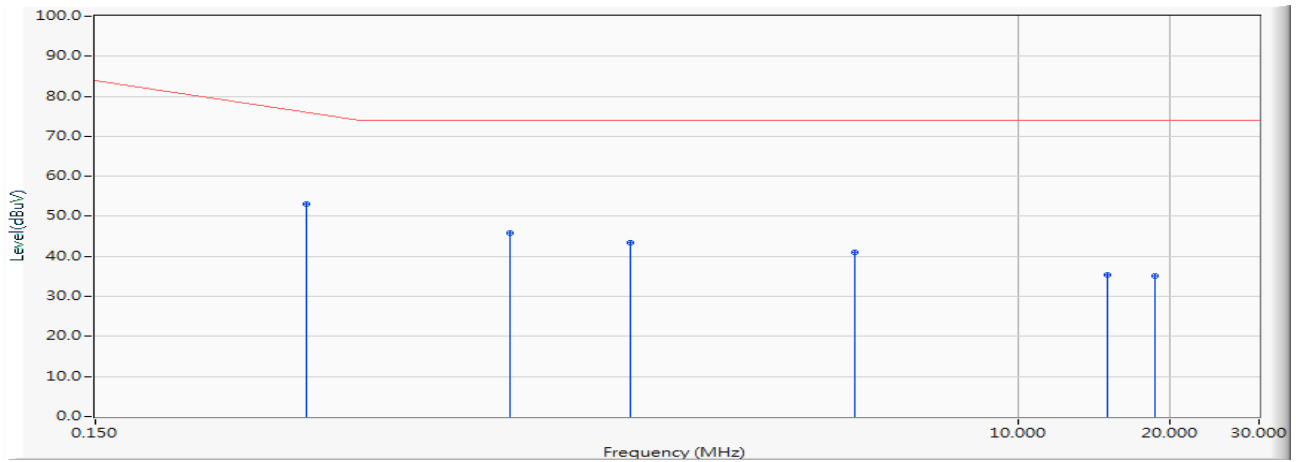

		Frequency (MHz)	Correct Factor (dB)	Reading Level (dBuV)	Measure Level (dBuV)	Margin (dB)	Limit (dBuV)	Detector Type
1	*	0.392	10.054	43.140	53.194	-23.892	77.086	AVERAGE
2		0.994	9.930	35.860	45.790	-28.210	74.000	AVERAGE
3		1.716	9.910	33.500	43.410	-30.590	74.000	AVERAGE
4		4.752	9.908	31.100	41.008	-32.992	74.000	AVERAGE
5		15.041	10.163	25.280	35.443	-38.557	74.000	AVERAGE
6		18.638	10.248	24.840	35.088	-38.912	74.000	AVERAGE

Note:

1. All Reading Levels are Quasi-Peak and average value.
2. " * ", means this data is the worst emission level.
3. Measurement Level = Reading Level + Correct Factor(Probe+Cable-Amp).

Site : SR8	Time : 2019/04/09 - 13:08
Limit : ISN_Voltage_A_00M_QP	Margin : 13
EUT : Network Camera	Probe : TESEQ_T8_42815 - Line1
Power : AC 230V/50Hz	Note :Mode 1, ISN 100M

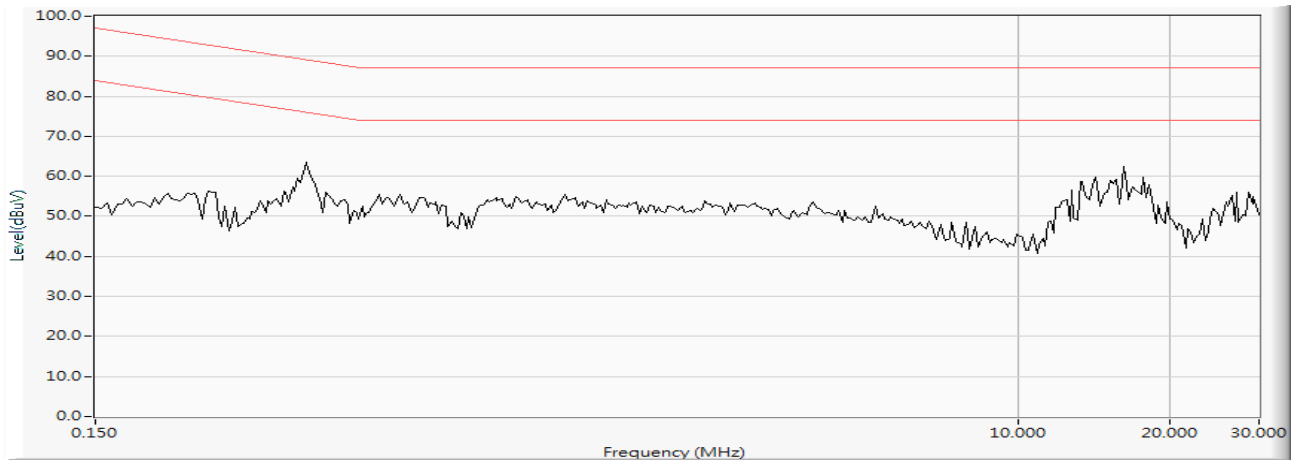

Site : SR8	Time : 2019/04/09 - 13:09
Limit : ISN_Voltage_A_00M_QP	Margin : 0
EUT : Network Camera	Probe : TESEQ_T8_42815 - Line1
Power : AC 230V/50Hz	Note :Mode 1, ISN 100M

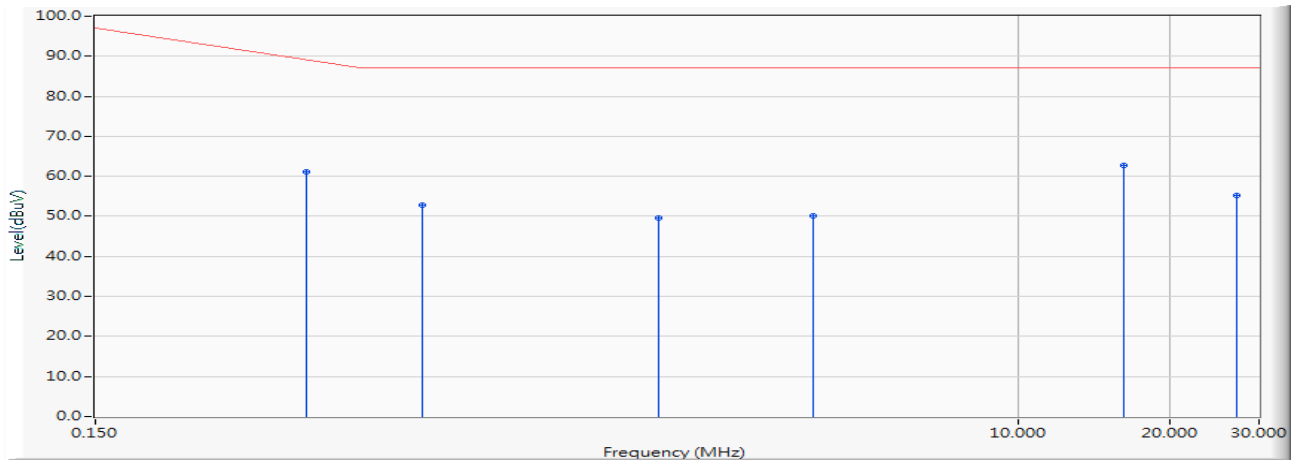

		Frequency (MHz)	Correct Factor (dB)	Reading Level (dBuV)	Measure Level (dBuV)	Margin (dB)	Limit (dBuV)	Detector Type
1		0.392	10.054	51.020	61.073	-29.013	90.086	QUASPEAK
2		0.666	9.964	42.940	52.904	-34.096	87.000	QUASPEAK
3		1.951	9.899	39.780	49.679	-37.321	87.000	QUASPEAK
4		3.951	9.900	40.340	50.240	-36.760	87.000	QUASPEAK
5	*	16.228	10.191	52.620	62.811	-24.189	87.000	QUASPEAK
6		27.158	10.547	44.740	55.287	-31.713	87.000	QUASPEAK

Note:

1. All Reading Levels are Quasi-Peak and average value.
2. " * ", means this data is the worst emission level.
3. Measurement Level = Reading Level + Correct Factor(Probe+Cable-Amp).

Site : SR8	Time : 2019/04/09 - 13:09
Limit : ISN_Voltage_A_00M_AV	Margin : 0
EUT : Network Camera	Probe : TESEQ_T8_42815 - Line1
Power : AC 230V/50Hz	Note :Mode 1, ISN 100M

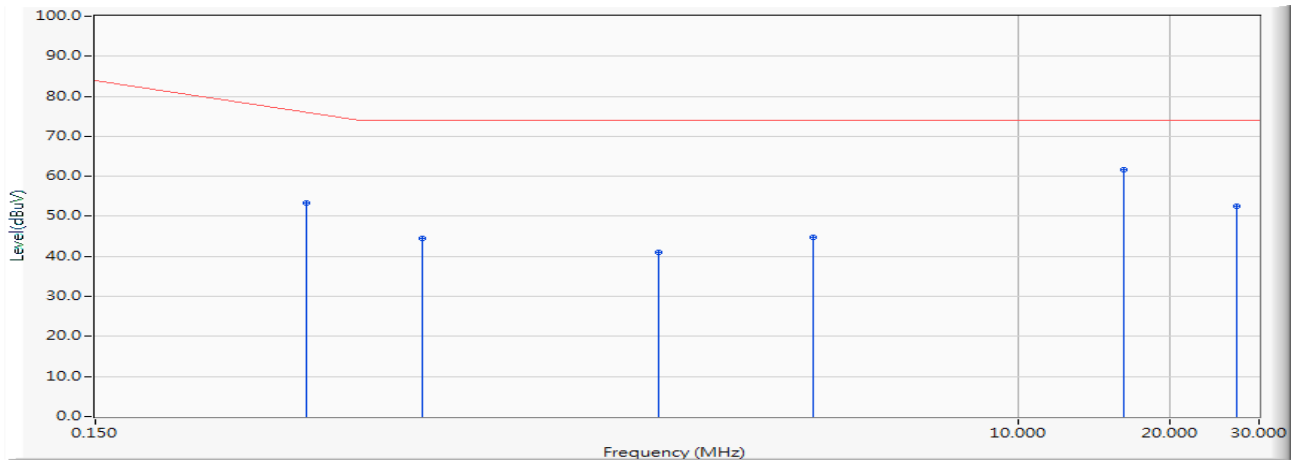

		Frequency (MHz)	Correct Factor (dB)	Reading Level (dBuV)	Measure Level (dBuV)	Margin (dB)	Limit (dBuV)	Detector Type
1		0.392	10.054	43.280	53.333	-23.753	77.086	AVERAGE
2		0.666	9.964	34.480	44.444	-29.556	74.000	AVERAGE
3		1.951	9.899	31.240	41.139	-32.861	74.000	AVERAGE
4		3.951	9.900	34.740	44.640	-29.360	74.000	AVERAGE
5	*	16.228	10.191	51.340	61.531	-12.469	74.000	AVERAGE
6		27.158	10.547	41.880	52.427	-21.573	74.000	AVERAGE

Note:

1. All Reading Levels are Quasi-Peak and average value.
2. " * ", means this data is the worst emission level.
3. Measurement Level = Reading Level + Correct Factor(Probe+Cable-Amp).

Site : SR8	Time : 2019/04/09 - 12:03
Limit : ISN_Voltage_A_00M_QP	Margin : 13
EUT : Network Camera	Probe : TESEQ_T8_42815 - Line1
Power : PoE	Note :Mode 1,ISN 10M

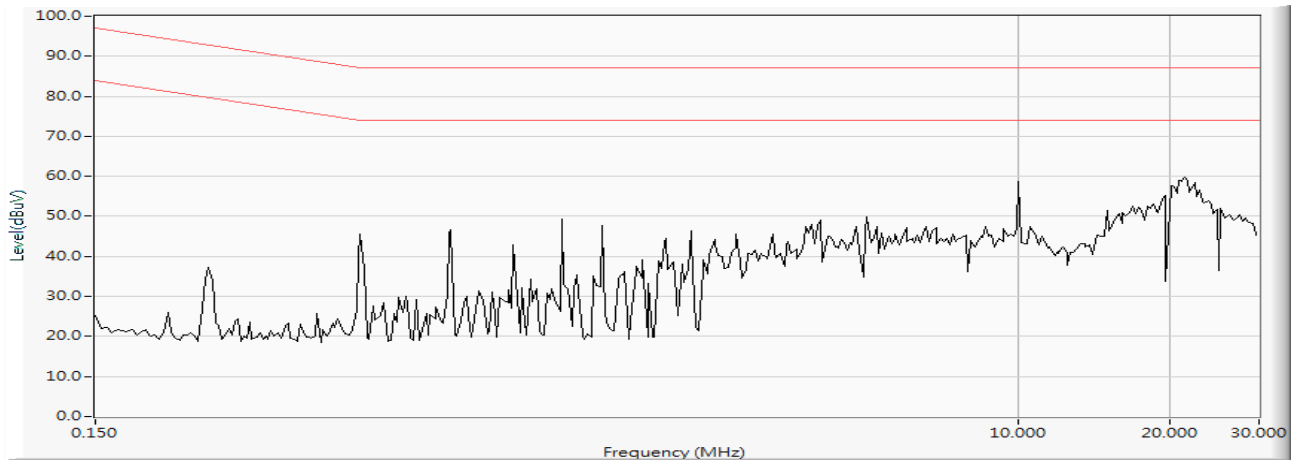

Site : SR8	Time : 2019/04/09 - 12:05
Limit : ISN_Voltage_A_00M_QP	Margin : 0
EUT : Network Camera	Probe : TESEQ_T8_42815 - Line1
Power : PoE	Note :Mode 1,ISN 10M

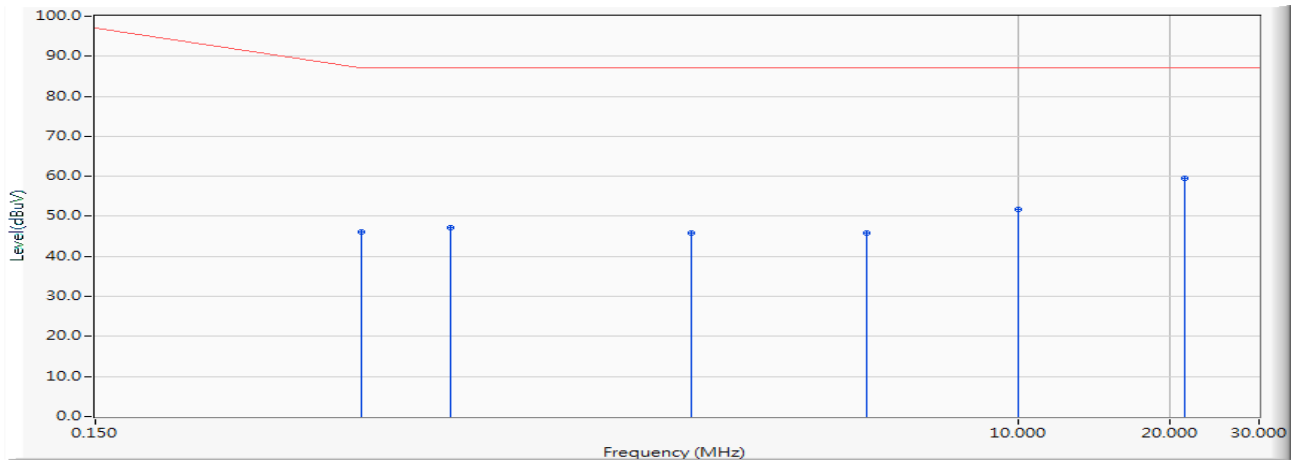

		Frequency (MHz)	Correct Factor (dB)	Reading Level (dBuV)	Measure Level (dBuV)	Margin (dB)	Limit (dBuV)	Detector Type
1		0.504	10.011	35.980	45.992	-41.008	87.000	QUASIPeAK
2		0.754	9.958	37.100	47.058	-39.942	87.000	QUASIPeAK
3		2.265	9.901	35.900	45.801	-41.199	87.000	QUASIPeAK
4		5.033	9.914	35.820	45.734	-41.266	87.000	QUASIPeAK
5		10.002	10.022	41.740	51.762	-35.238	87.000	QUASIPeAK
6	*	21.384	10.328	49.060	59.388	-27.612	87.000	QUASIPeAK

Note:

1. All Reading Levels are Quasi-Peak and average value.
2. " * ", means this data is the worst emission level.
3. Measurement Level = Reading Level + Correct Factor(Probe+Cable-Amp).

Site : SR8	Time : 2019/04/09 - 12:05
Limit : ISN_Voltage_A_00M_AV	Margin : 0
EUT : Network Camera	Probe : TESEQ_T8_42815 - Line1
Power : PoE	Note :Mode 1,ISN 10M

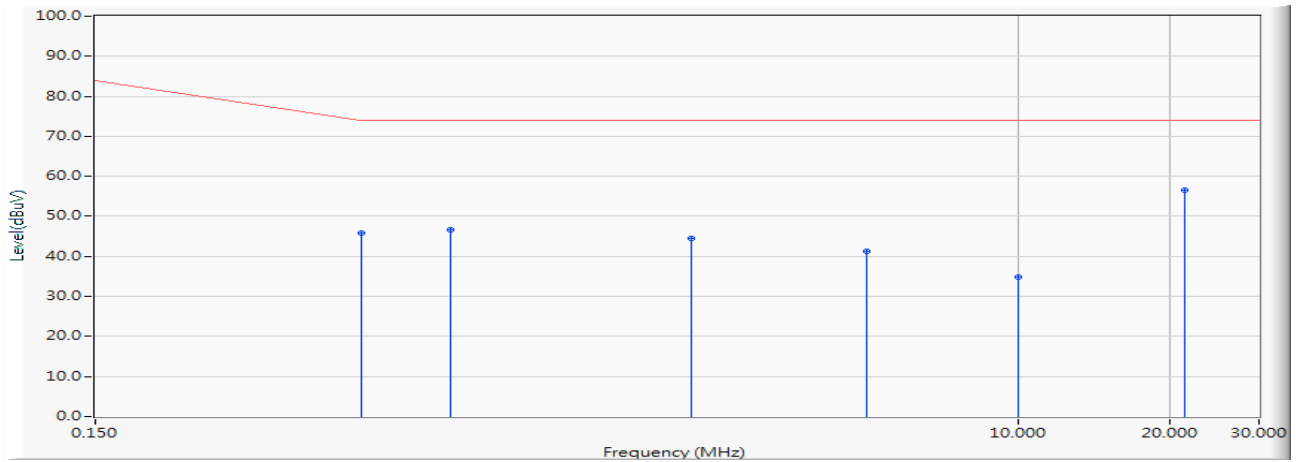

		Frequency (MHz)	Correct Factor (dB)	Reading Level (dBuV)	Measure Level (dBuV)	Margin (dB)	Limit (dBuV)	Detector Type
1		0.504	10.011	35.740	45.752	-28.248	74.000	AVERAGE
2		0.754	9.958	36.660	46.618	-27.382	74.000	AVERAGE
3		2.265	9.901	34.720	44.621	-29.379	74.000	AVERAGE
4		5.033	9.914	31.420	41.334	-32.666	74.000	AVERAGE
5		10.002	10.022	24.900	34.922	-39.078	74.000	AVERAGE
6	*	21.384	10.328	46.200	56.528	-17.472	74.000	AVERAGE

Note:

1. All Reading Levels are Quasi-Peak and average value.
2. " * ", means this data is the worst emission level.
3. Measurement Level = Reading Level + Correct Factor(Probe+Cable-Amp).

Site : SR8	Time : 2019/04/09 - 11:59
Limit : ISN_Voltage_A_00M_QP	Margin : 13
EUT : Network Camera	Probe : TESEQ_T8_42815 - Line1
Power : PoE	Note :Mode 1,ISN 100M

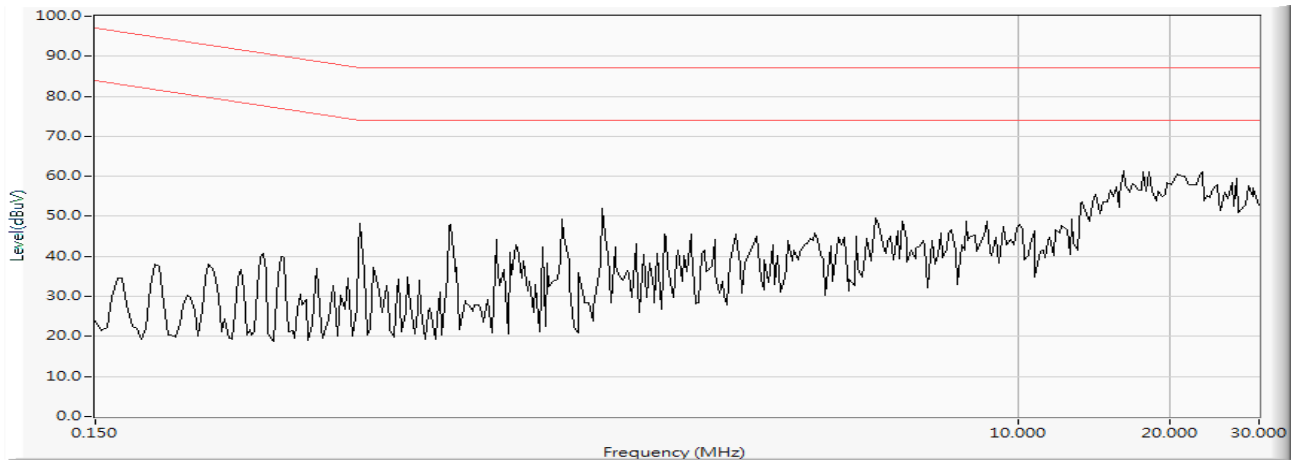

Site : SR8	Time : 2019/04/09 - 12:01
Limit : ISN_Voltage_A_00M_QP	Margin : 0
EUT : Network Camera	Probe : TESEQ_T8_42815 - Line1
Power : PoE	Note :Mode 1,ISN 100M

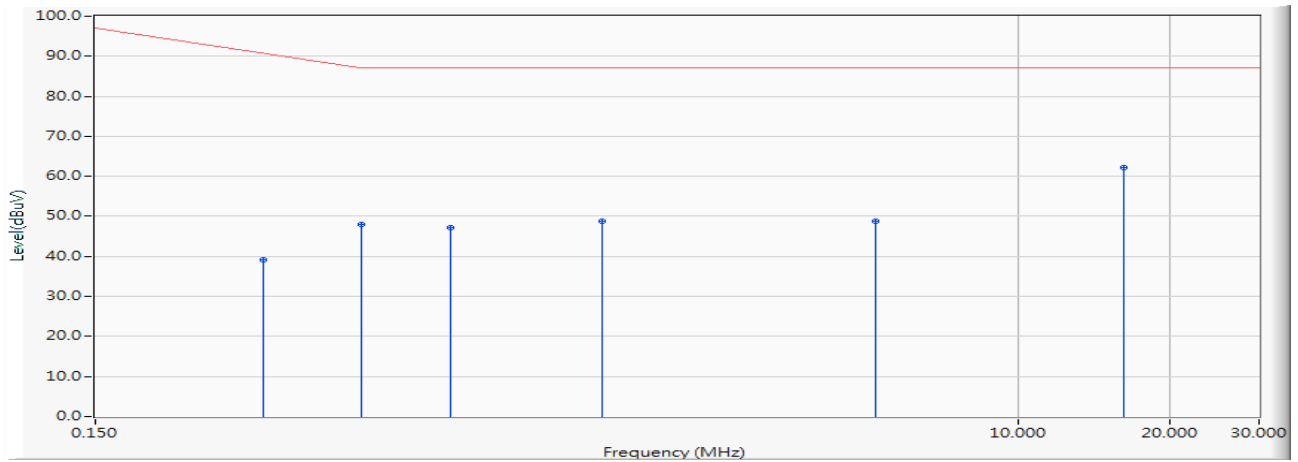

		Frequency (MHz)	Correct Factor (dB)	Reading Level (dBuV)	Measure Level (dBuV)	Margin (dB)	Limit (dBuV)	Detector Type
1		0.322	10.108	29.000	39.108	-52.978	92.086	QUASPEAK
2		0.504	10.011	37.900	47.912	-39.088	87.000	QUASPEAK
3		0.754	9.958	37.260	47.218	-39.782	87.000	QUASPEAK
4		1.509	9.916	38.980	48.896	-38.104	87.000	QUASPEAK
5		5.236	9.919	38.820	48.739	-38.261	87.000	QUASPEAK
6	*	16.228	10.191	52.040	62.231	-24.769	87.000	QUASPEAK

Note:

1. All Reading Levels are Quasi-Peak and average value.
2. " * ", means this data is the worst emission level.
3. Measurement Level = Reading Level + Correct Factor(Probe+Cable-Amp).

Site : SR8	Time : 2019/04/09 - 12:01
Limit : ISN_Voltage_A_00M_AV	Margin : 0
EUT : Network Camera	Probe : TESEQ_T8_42815 - Line1
Power : POE	Note :Mode 1,ISN 100M

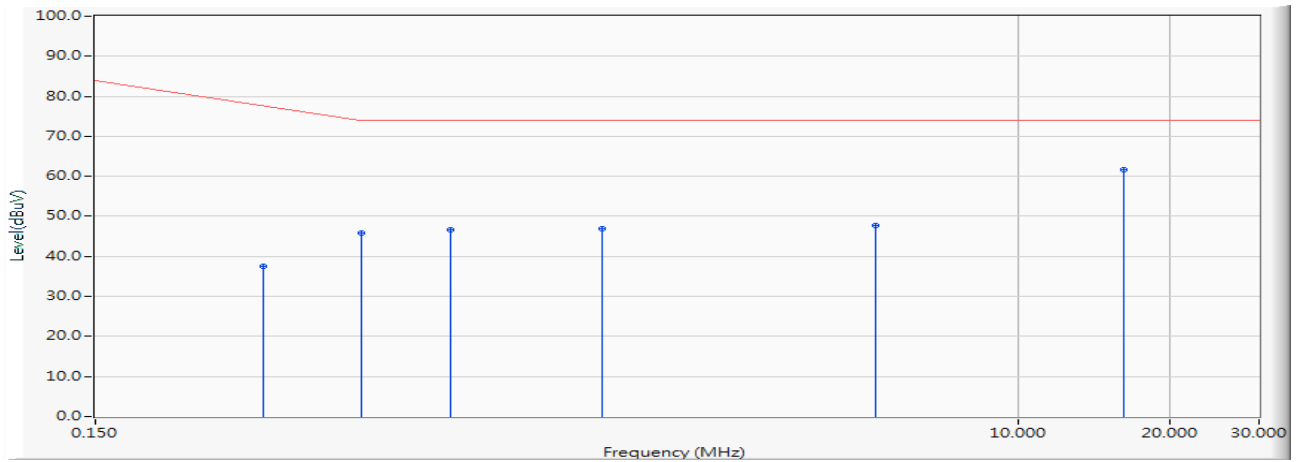

		Frequency (MHz)	Correct Factor (dB)	Reading Level (dBuV)	Measure Level (dBuV)	Margin (dB)	Limit (dBuV)	Detector Type
1		0.322	10.108	27.340	37.448	-41.638	79.086	AVERAGE
2		0.504	10.011	35.880	45.892	-28.108	74.000	AVERAGE
3		0.754	9.958	36.740	46.698	-27.302	74.000	AVERAGE
4		1.509	9.916	37.080	46.996	-27.004	74.000	AVERAGE
5		5.236	9.919	37.700	47.619	-26.381	74.000	AVERAGE
6	*	16.228	10.191	51.340	61.531	-12.469	74.000	AVERAGE

Note:

1. All Reading Levels are Quasi-Peak and average value.
2. " * ", means this data is the worst emission level.
3. Measurement Level = Reading Level + Correct Factor(Probe+Cable-Amp).

4.7. Test Photograph

Test Mode : Mode 1: IB9387-EHT, Adapter

Description : Front View of ISN Test



Test Mode : Mode 1: IB9387-EHT, Adapter

Description : Back View of ISN Test



Test Mode : Mode 2: IB9387-EHT, PoE

Description : Front View of ISN Test



Test Mode : Mode 2: IB9387-EHT, PoE

Description : Back View of ISN Test



5. Radiated Emission

5.1. Test Specification

According to EN 50121-4 clause 5 and EN 61000-6-4 Table 1

5.2. Test Setup

Under 1GHz Test Setup:

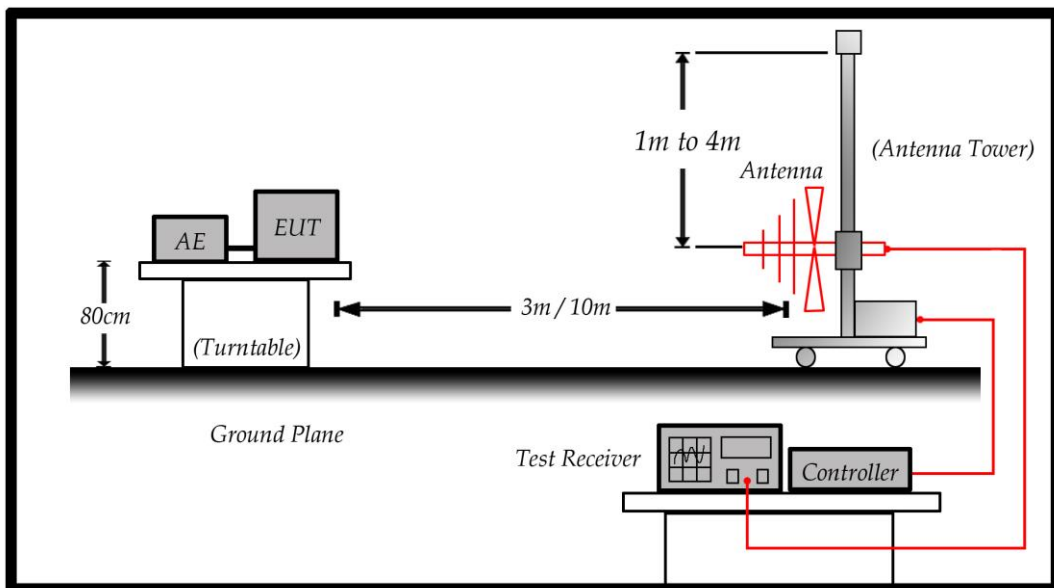

Above 1GHz Test Setup:

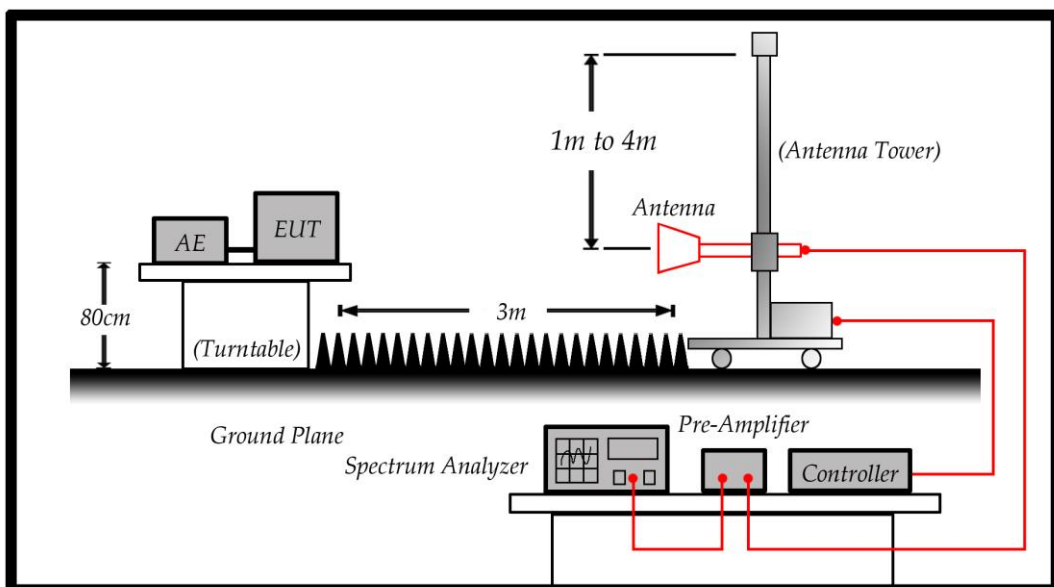

5.3. Limit

Limits		
Frequency MHz	Distance (m)	dBuV/m
30 – 230	10	40
230 – 1000	10	47

Limits			
Frequency (GHz)	Distance (m)	Peak (dBuV/m)	Average (dBuV/m)
1 – 3	3	76	56
3 – 6	3	80	60

Remark:

1. The tighter limit shall apply at the edge between two frequency bands.
2. Distance refers to the distance in meters between the measuring instrument antenna and the closed point of any part of the device or system.

Highest frequency generated or used in the device or on which the device operates or tunes (MHz)	Upper frequency of measurement range (MHz)
Below 108	1000
108 – 500	2000
500 – 1000	5000
Above 1000	5 th harmonic of the highest frequency or 6 GHz, whichever is lower

5.4. Test Procedure

According to CISPR 16-2-3.

The EUT and its simulators are placed on a turn table which is 0.8 meter above ground. The turn table can rotate 360 degrees to determine the position of the maximum emission level. The EUT was positioned such that the distance from antenna to the EUT was 10 meters. The antenna can move up and down between 1 meter and 4 meters to find out the maximum emission level.

Both horizontal and vertical polarization of the antenna are set on measurement. In order to find the maximum emission, all of the interface cables must be manipulated on radiated measurement.

Radiated emissions were investigated over the frequency range from 30MHz to 1GHz using a receiver bandwidth of 120kHz. Radiated was performed at an antenna to EUT distance of 10 meters.

5.5. Deviation from Test Standard

No deviation.

5.6. Test Result

Site : SITE7	Time : 2019/04/22 - 19:24
Limit : CISPR_A_10M_QP	Margin : 6
EUT : Network Camera	Probe : Site7_VULB9168_10m_1902 - HORIZONTAL
Power : AC 230V/50Hz	Note : Mode 1

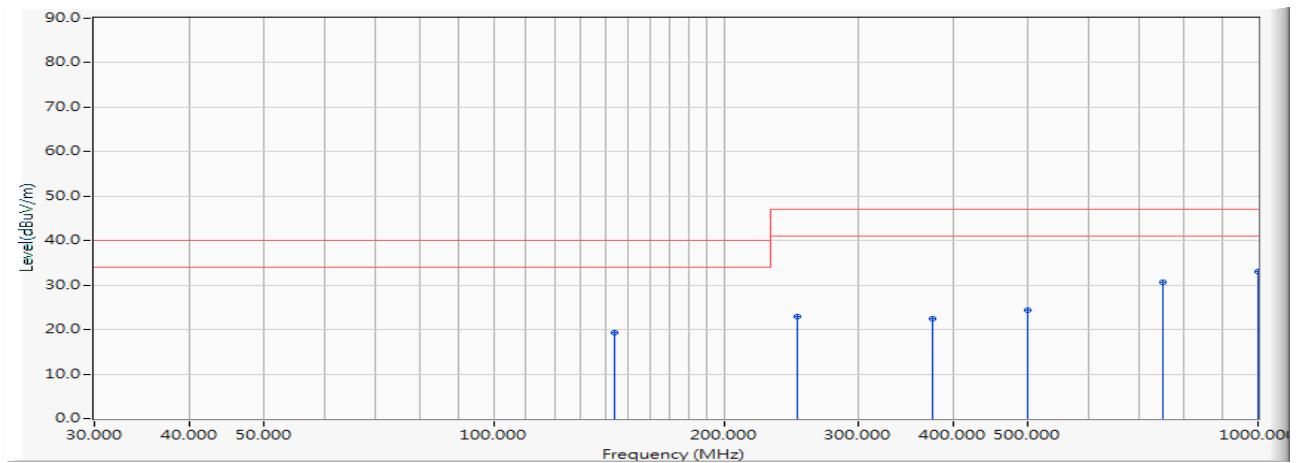

	Frequency (MHz)	Correct Factor (dB)	Reading Level (dBuV)	Measure Level (dBuV/m)	Margin (dB)	Limit (dBuV/m)	Detector Type	Ant Pos (cm)	Table Pos (deg)
1	144.000	-10.699	30.000	19.301	-20.699	40.000	QUASPEAK	390.000	54.000
2	250.000	-10.488	33.400	22.912	-24.088	47.000	QUASPEAK	380.000	124.000
3	375.000	-5.843	28.400	22.557	-24.443	47.000	QUASPEAK	300.000	95.000
4	500.000	-1.815	26.200	24.385	-22.615	47.000	QUASPEAK	200.000	-47.000
5	750.000	4.566	26.000	30.565	-16.435	47.000	QUASPEAK	120.000	14.000
6	* 1000.000	7.830	25.300	33.130	-13.870	47.000	QUASPEAK	100.000	-112.000

Note:

1. All Readings below 1GHz are Quasi-Peak, above are performed with peak and/or average measurements as necessary.
2. " * ", means this data is the worst emission level.
3. Measurement Level = Reading Level + Correct Factor(Probe+Cable-Amp).

Site : SITE7	Time : 2019/04/22 - 19:25
Limit : CISPR_A_10M_QP	Margin : 6
EUT : Network Camera	Probe : Site7_VULB9168_10m_1902 - VERTICAL
Power : AC 230V/50Hz	Note : Mode 1

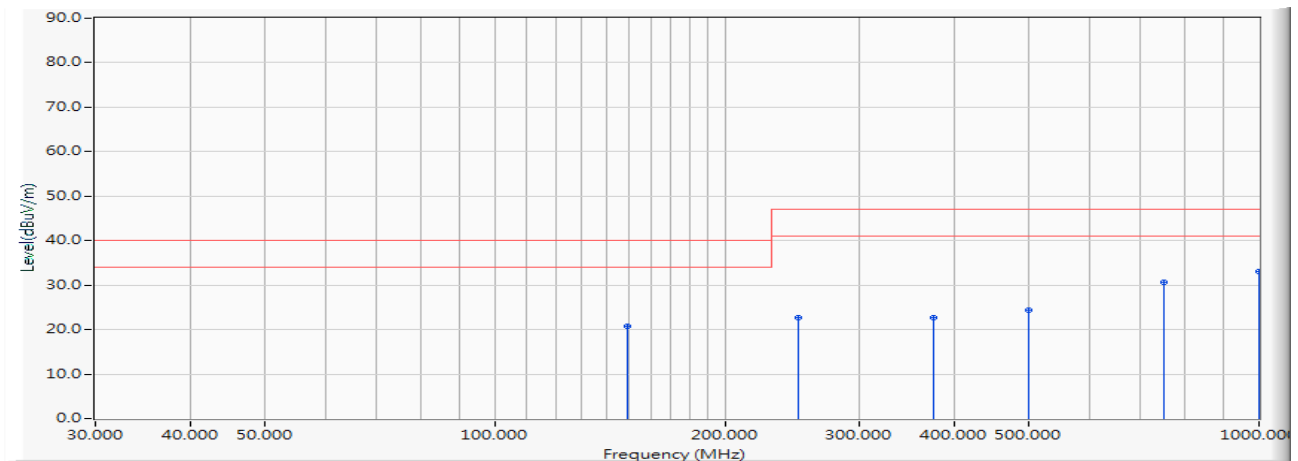

	Frequency (MHz)	Correct Factor (dB)	Reading Level (dBuV)	Measure Level (dBuV/m)	Margin (dB)	Limit (dBuV/m)	Detector Type	Ant Pos (cm)	Table Pos (deg)
1	148.900	-10.487	31.200	20.713	-19.287	40.000	QUASPEAK	100.000	64.000
2	250.000	-10.488	33.200	22.712	-24.288	47.000	QUASPEAK	100.000	97.000
3	375.000	-5.843	28.600	22.757	-24.243	47.000	QUASPEAK	100.000	62.000
4	500.000	-1.815	26.300	24.485	-22.515	47.000	QUASPEAK	300.000	51.000
5	750.000	4.566	26.000	30.565	-16.435	47.000	QUASPEAK	260.000	31.000
6	* 1000.000	7.830	25.300	33.130	-13.870	47.000	QUASPEAK	175.000	-71.000

Note:

1. All Readings below 1GHz are Quasi-Peak, above are performed with peak and/or average measurements as necessary.
2. " * ", means this data is the worst emission level.
3. Measurement Level = Reading Level + Correct Factor(Probe+Cable-Amp).

Site : SITE7	Time : 2019/04/22 - 16:41
Limit : CISPR_A_10M_QP	Margin : 6
EUT : Network Camera	Probe : Site7_VULB9168_10m_1902 - HORIZONTAL
Power : PoE	Note : Mode 2

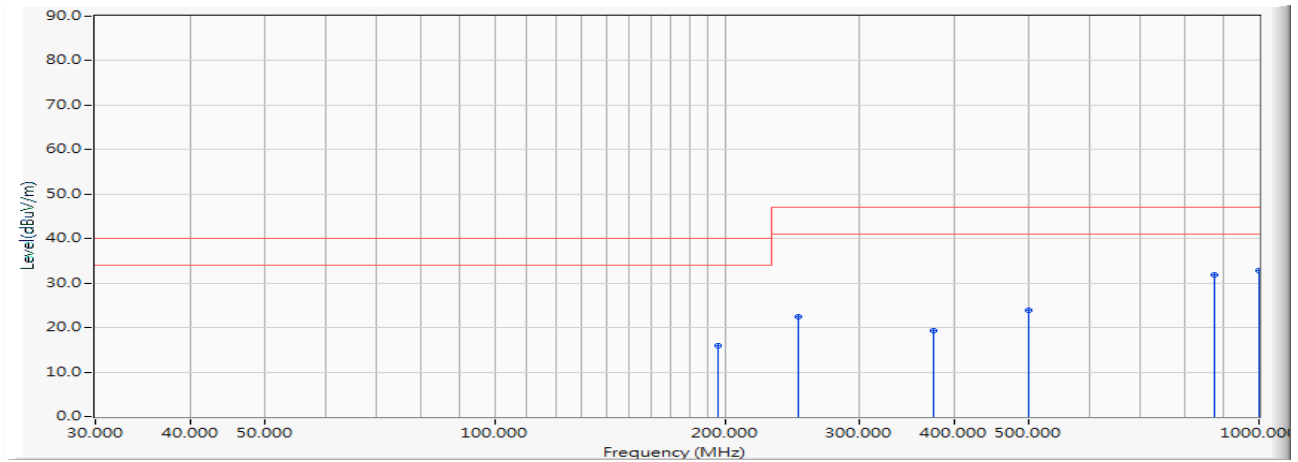

	Frequency (MHz)	Correct Factor (dB)	Reading Level (dBuV)	Measure Level (dBuV/m)	Margin (dB)	Limit (dBuV/m)	Detector Type	Ant Pos (cm)	Table Pos (deg)
1	196.200	-12.617	28.600	15.983	-24.017	40.000	QUASIPeAK	380.000	51.000
2	250.000	-10.488	33.000	22.512	-24.488	47.000	QUASIPeAK	370.000	42.000
3	375.000	-5.843	25.100	19.257	-27.743	47.000	QUASIPeAK	300.000	33.000
4	500.000	-1.815	25.600	23.785	-23.215	47.000	QUASIPeAK	200.000	-41.000
5	875.000	6.141	25.600	31.741	-15.259	47.000	QUASIPeAK	100.000	94.000
6	* 1000.000	7.830	24.900	32.730	-14.270	47.000	QUASIPeAK	100.000	-48.000

Note:

1. All Readings below 1GHz are Quasi-Peak, above are performed with peak and/or average measurements as necessary.
2. " * ", means this data is the worst emission level.
3. Measurement Level = Reading Level + Correct Factor(Probe+Cable-Amp).

Site : SITE7	Time : 2019/04/22 - 16:41
Limit : CISPR_A_10M_QP	Margin : 6
EUT : Network Camera	Probe : Site7_VULB9168_10m_1902 - VERTICAL
Power : PoE	Note : Mode 2

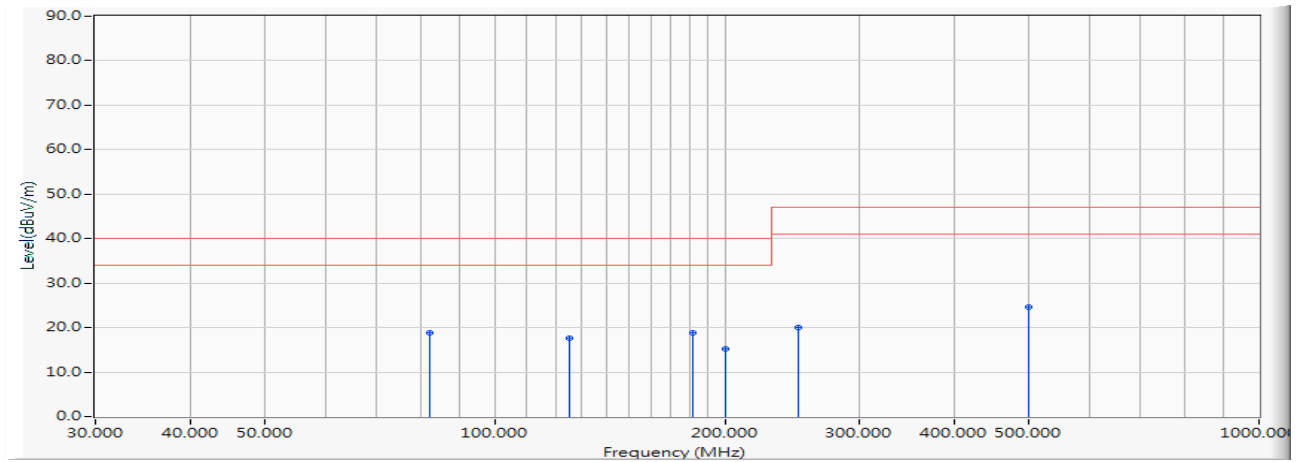

	Frequency (MHz)	Correct Factor (dB)	Reading Level (dBuV)	Measure Level (dBuV/m)	Margin (dB)	Limit (dBuV/m)	Detector Type	Ant Pos (cm)	Table Pos (deg)
1	82.000	-15.893	34.600	18.707	-21.293	40.000	QUASIPeAK	100.000	91.000
2	125.000	-12.365	30.000	17.635	-22.365	40.000	QUASIPeAK	100.000	55.000
3	* 181.200	-11.356	30.200	18.844	-21.156	40.000	QUASIPeAK	100.000	139.000
4	200.000	-12.745	28.000	15.255	-24.745	40.000	QUASIPeAK	100.000	-48.000
5	250.000	-10.488	30.600	20.112	-26.888	47.000	QUASIPeAK	100.000	-89.000
6	500.000	-1.815	26.400	24.585	-22.415	47.000	QUASIPeAK	300.000	89.000

Note:

1. All Readings below 1GHz are Quasi-Peak, above are performed with peak and/or average measurements as necessary.
2. " * ", means this data is the worst emission level.
3. Measurement Level = Reading Level + Correct Factor(Probe+Cable-Amp).

Site: CB7	Time: 2019/04/24 - 02:03
Limit: CISPR_A(Above_1G)	Margin: 0
Probe: CB7_Horn_3117_1808	Polarity: Horizontal
EUT: Network Camera	Power: AC 230V/50Hz
Note: Mode 1	

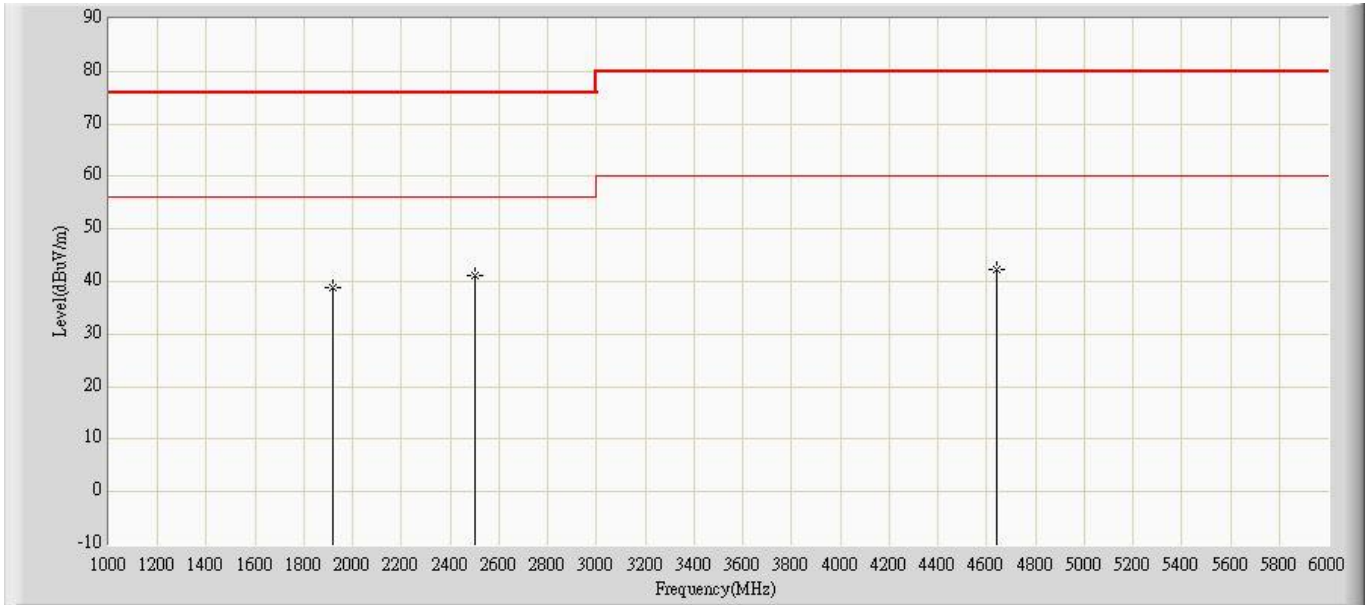

No	Flag	Mark	Frequency (MHz)	Measure Level (dBuV/m)	Reading Level (dBuV)	Over Limit (dB)	Limit (dBuV/m)	Factor	Ant Pos (cm)	Table Pos (deg)	Type
1			1920.000	38.968	49.280	-37.032	76.000	-10.312	158	64	PK
2		*	2500.000	41.157	49.381	-34.843	76.000	-8.224	100	-178	PK
3			4640.000	42.373	45.667	-37.627	80.000	-3.294	112	92	PK

Note:

1. All Readings below 1GHz are Quasi-Peak, above are performed with peak and/or average measurements as necessary.
2. " * ", means this data is the worst emission level.
3. Measurement Level = Reading Level + Factor(Probe+Cable-Amp).

Site: CB7	Time: 2019/04/24 - 02:03
Limit: CISPR_A(Above_1G)	Margin: 0
Probe: CB7_Horn_3117_1808	Polarity: Vertical
EUT: Network Camera	Power: AC 230V/50Hz
Note: Mode 1	

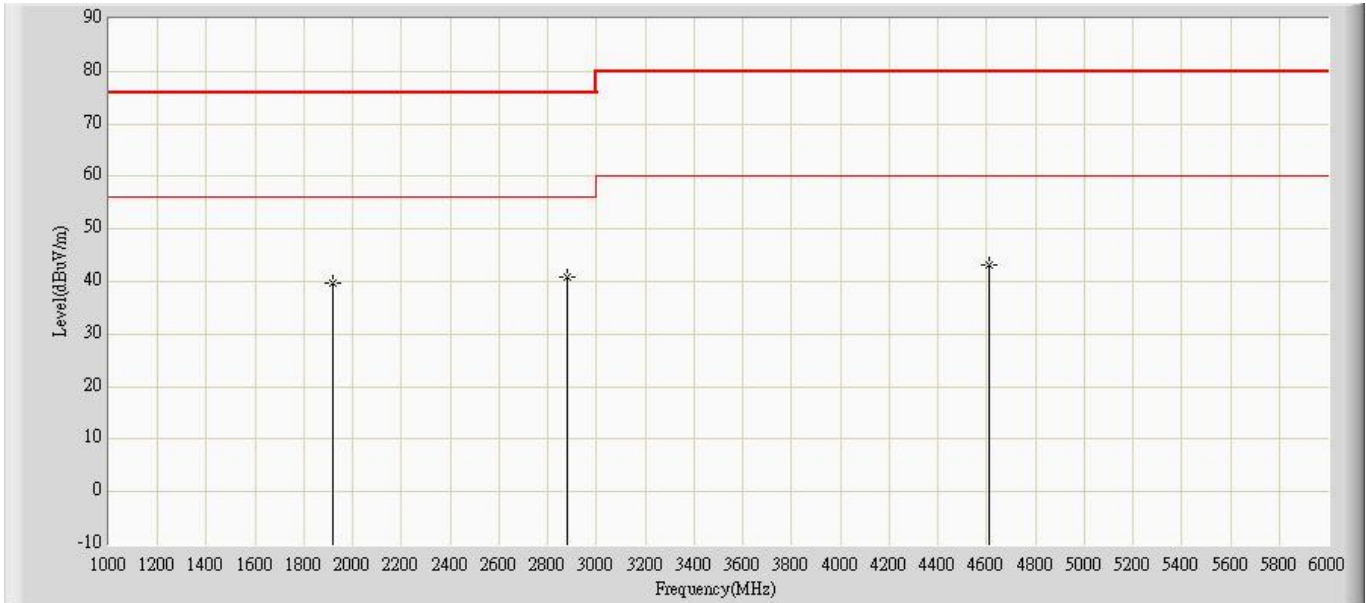

No	Flag	Mark	Frequency (MHz)	Measure Level (dBuV/m)	Reading Level (dBuV)	Over Limit (dB)	Limit (dBuV/m)	Factor	Ant Pos (cm)	Table Pos (deg)	Type
1			1920.000	39.652	49.964	-36.348	76.000	-10.312	185	125	PK
2		*	2880.000	41.000	48.500	-35.000	76.000	-7.500	175	72	PK
3			4610.000	43.080	46.481	-36.920	80.000	-3.400	171	111	PK

Note:

1. All Readings below 1GHz are Quasi-Peak, above are performed with peak and/or average measurements as necessary.
2. " * ", means this data is the worst emission level.
3. Measurement Level = Reading Level + Factor(Probe+Cable-Amp).

Site: CB7	Time: 2019/04/24 - 02:09
Limit: CISPR_A(Above_1G)	Margin: 0
Probe: CB7_Horn_3117_1808	Polarity: Horizontal
EUT: Network Camera	Power: PoE
Note: Mode 2	

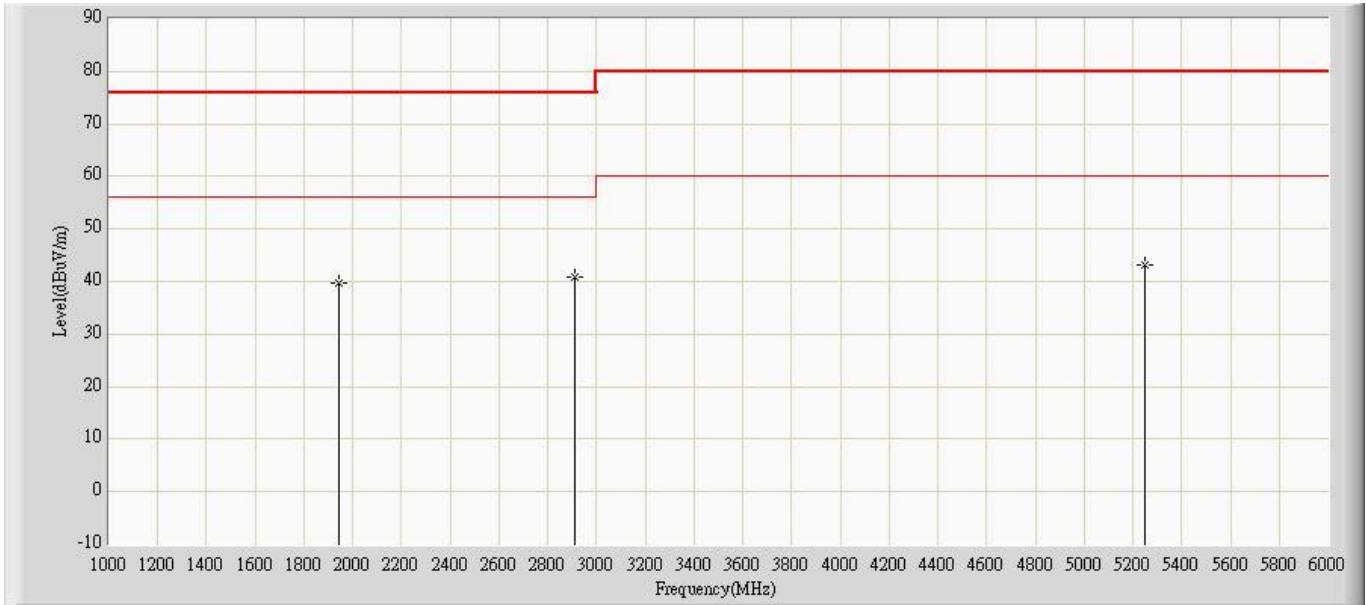

No	Flag	Mark	Frequency (MHz)	Measure Level (dBuV/m)	Reading Level (dBuV)	Over Limit (dB)	Limit (dBuV/m)	Factor	Ant Pos (cm)	Table Pos (deg)	Type
1			1940.000	39.683	49.841	-36.317	76.000	-10.158	179	193	PK
2		*	2910.000	40.867	48.263	-35.133	76.000	-7.396	199	123	PK
3			5250.000	43.275	46.245	-36.725	80.000	-2.970	118	-23	PK

Note:

1. All Readings below 1GHz are Quasi-Peak, above are performed with peak and/or average measurements as necessary.
2. " * ", means this data is the worst emission level.
3. Measurement Level = Reading Level + Factor(Probe+Cable-Amp).

Site: CB7	Time: 2019/04/24 - 02:10
Limit: CISPR_A(Above_1G)	Margin: 0
Probe: CB7_Horn_3117_1808	Polarity: Vertical
EUT: Network Camera	Power: PoE
Note: Mode 2	

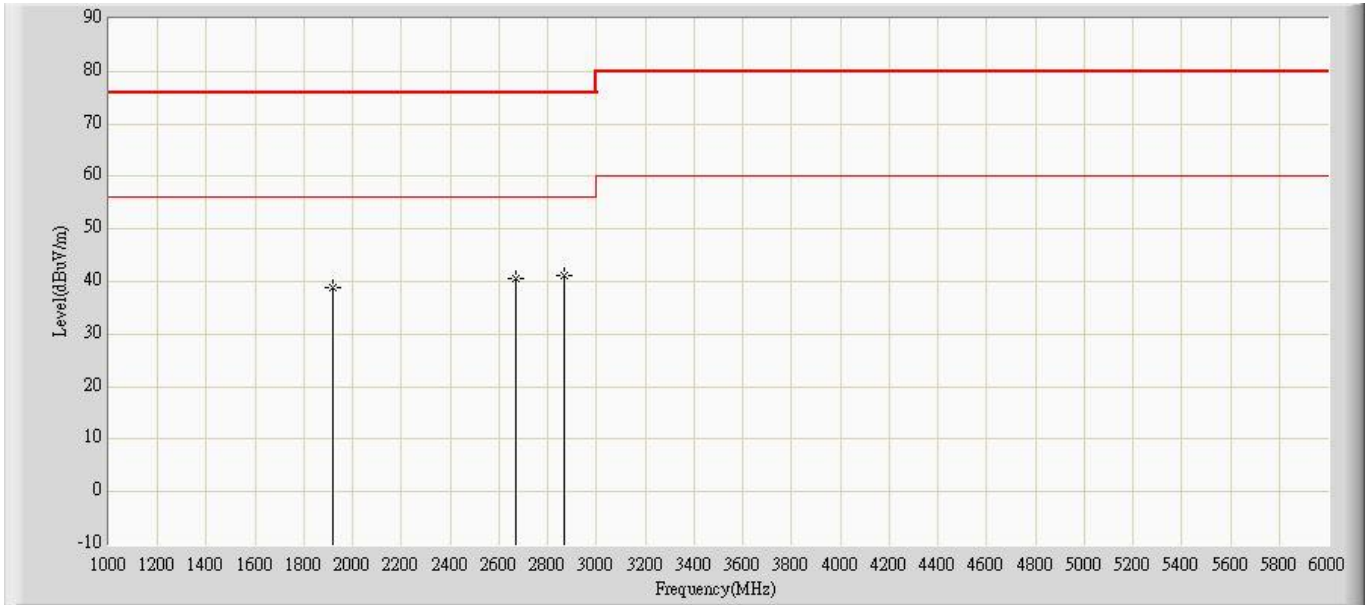

No	Flag	Mark	Frequency (MHz)	Measure Level (dBuV/m)	Reading Level (dBuV)	Over Limit (dB)	Limit (dBuV/m)	Factor	Ant Pos (cm)	Table Pos (deg)	Type
1			1920.000	38.970	49.282	-37.030	76.000	-10.312	117	198	PK
2			2670.000	40.523	48.204	-35.477	76.000	-7.681	164	-30	PK
3		*	2870.000	41.186	48.686	-34.814	76.000	-7.500	179	181	PK

Note:

1. All Readings below 1GHz are Quasi-Peak, above are performed with peak and/or average measurements as necessary.
2. " * ", means this data is the worst emission level.
3. Measurement Level = Reading Level + Factor(Probe+Cable-Amp).

5.7. Test Photograph

Test Mode : Mode 1: IB9387-EHT, Adapter

Description : Front View of Radiated Test



Test Mode : Mode 1: IB9387-EHT, Adapter

Description : Back View of Radiated Test



Test Mode : Mode 1: IB9387-EHT, Adapter

Description : Front View of High Frequency Radiated Test



Test Mode : Mode 2: IB9387-EHT, PoE

Description : Front View of Radiated Test



Test Mode : Mode 2: IB9387-EHT, PoE

Description : Back View of Radiated Test

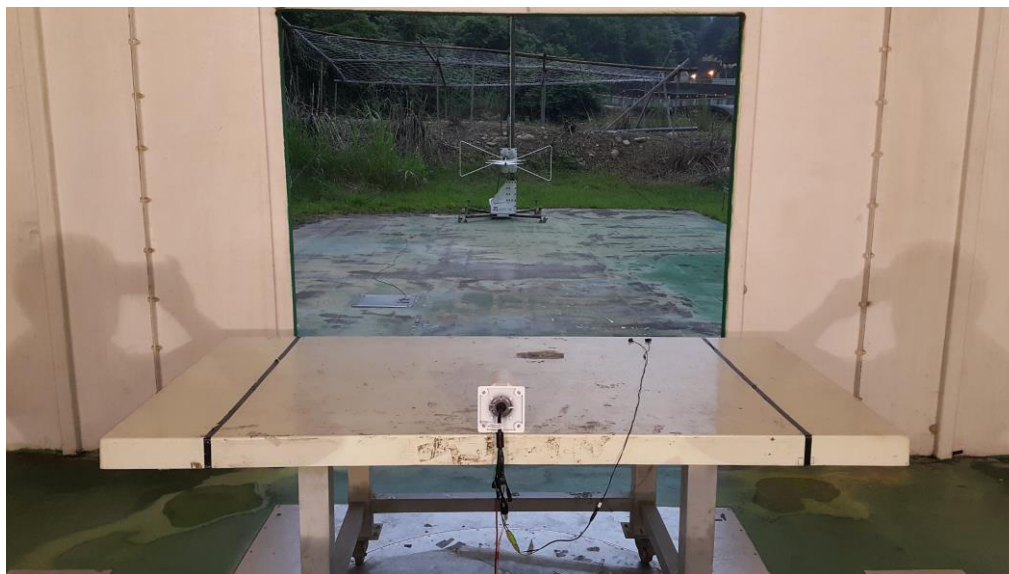

Test Mode : Mode 2: IB9387-EHT, PoE

Description : Front View of High Frequency Radiated Test



6. Electrostatic Discharge

6.1. Test Specification

According to EN 50121-4 clause 6.

6.2. Test Setup

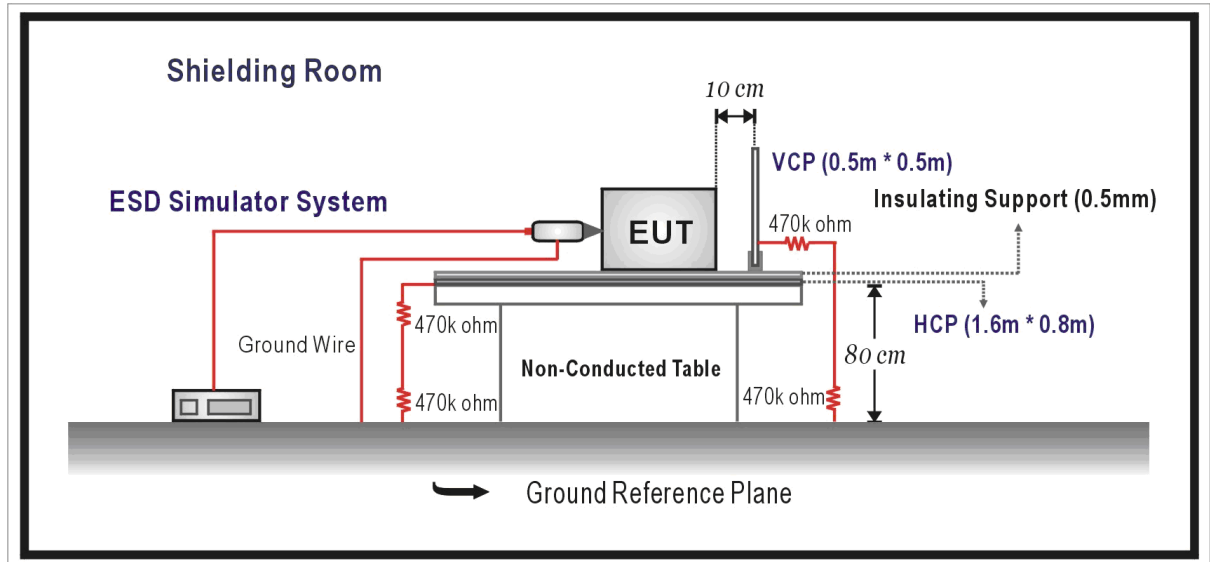

6.3. Limit

Item	Environmental Phenomena	Units	Test Specification	Performance Criteria
Enclosure Port				
	Electrostatic Discharge	kV(Charge Voltage)	±8 Air Discharge ±6 Contact Discharge	B

6.4. Test Procedure

According to EN 61000-4-2.

Direct application of discharges to the EUT:

Contact discharge was applied only to conductive surfaces of the EUT.

Air discharges were applied only to non-conductive surfaces of the EUT.

During the test, it was performed with single discharges. For the single discharge time between successive single discharges will be keep longer 1 second. It was at least ten single discharges with positive and negative at the same selected point.

The selected point, which was performed with electrostatic discharge, was marked on the red label of the EUT.

Indirect application of discharges to the EUT:

Vertical Coupling Plane (VCP):

The coupling plane, of dimensions 0.5m x 0.5m, is placed parallel to, and positioned at a distance 0.1m from, the EUT, with the Discharge Electrode touching the coupling plane.

The four faces of the EUT will be performed with electrostatic discharge. It was at least ten single discharges with positive and negative at the same selected point.

Horizontal Coupling Plane (HCP):

The coupling plane is placed under to the EUT. The generator shall be positioned vertically at a distance of 0.1m from the EUT, with the Discharge Electrode touching the coupling plane.

The four faces of the EUT will be performed with electrostatic discharge. It was at least ten single discharges with positive and negative at the same selected point.

6.5. Deviation from Test Standard

No deviation..

6.6. Test Result

Product	Network Camera		
Test Item	Electrostatic Discharge		
Test Mode	Mode 1: IB9387-EHT, Adapter		
Date of Test	2019/05/12	Test Site	No.6 Shielded Room

Item	Amount of Discharge	Voltage	Required Criteria	Complied To Criteria (A,B,C)	Results
Air Discharge	10	+8kV	B	A	Pass
	10	-8kV	B	A	Pass
Contact Discharge	25	+6kV	B	A	Pass
	25	-6kV	B	A	Pass
Indirect Discharge (HCP)	25	+6kV	B	A	Pass
	25	-6kV	B	A	Pass
Indirect Discharge (VCP)	25	+6kV	B	A	Pass
	25	-6kV	B	A	Pass

Note:

The testing performed is from lowest level up to the highest level as required by standard, but only highest level is shown on the report.

NR: No Requirement

- Meet criteria A: Operate as intended during and after the test
- Meet criteria B: Operate as intended after the test
- Meet criteria C: Loss/Error of function
- Additional Information
 - EUT stopped operation and could / could not be reset by operator at ____ kV.
 - No false alarms or other malfunctions were observed during or after the test.

Remark:

The Contact discharges were applied at least total 200 discharges at a minimum of four test points.

Product	Network Camera		
Test Item	Electrostatic Discharge		
Test Mode	Mode 2: IB9387-EHT, PoE		
Date of Test	2019/05/12	Test Site	No.6 Shielded Room

Item	Amount of Discharge	Voltage	Required Criteria	Complied To Criteria (A,B,C)	Results
Air Discharge	10	+8kV	B	A	Pass
	10	-8kV	B	A	Pass
Contact Discharge	25	+6kV	B	A	Pass
	25	-6kV	B	A	Pass
Indirect Discharge (HCP)	25	+6kV	B	A	Pass
	25	-6kV	B	A	Pass
Indirect Discharge (VCP)	25	+6kV	B	A	Pass
	25	-6kV	B	A	Pass

Note:

The testing performed is from lowest level up to the highest level as required by standard, but only highest level is shown on the report.

NR: No Requirement

- Meet criteria A: Operate as intended during and after the test
- Meet criteria B: Operate as intended after the test
- Meet criteria C: Loss/Error of function
- Additional Information
 - EUT stopped operation and could / could not be reset by operator at ____ kV.
 - No false alarms or other malfunctions were observed during or after the test.

Remark:

The Contact discharges were applied at least total 200 discharges at a minimum of four test points.

6.7. Test Photograph

Test Mode : Mode 1: IB9387-EHT, Adapter

Description : ESD Test Setup



Test Mode : Mode 2: IB9387-EHT, PoE

Description : ESD Test Setup

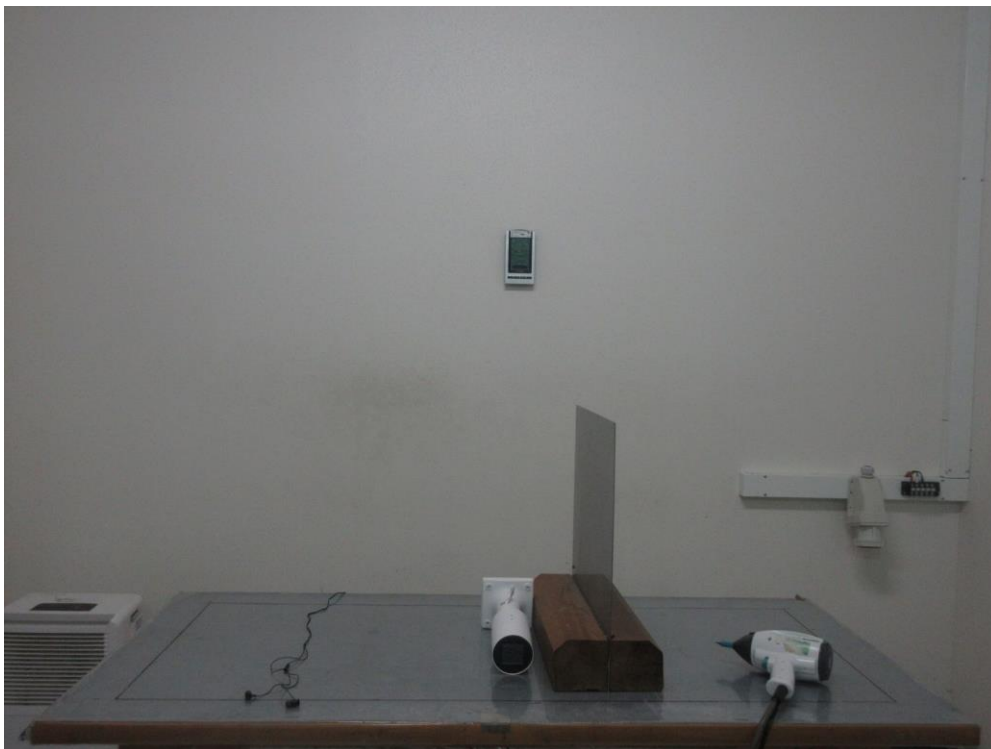

6.8. EUT to dot photo for ESD test

Test dot : (Air DISCHARGE)

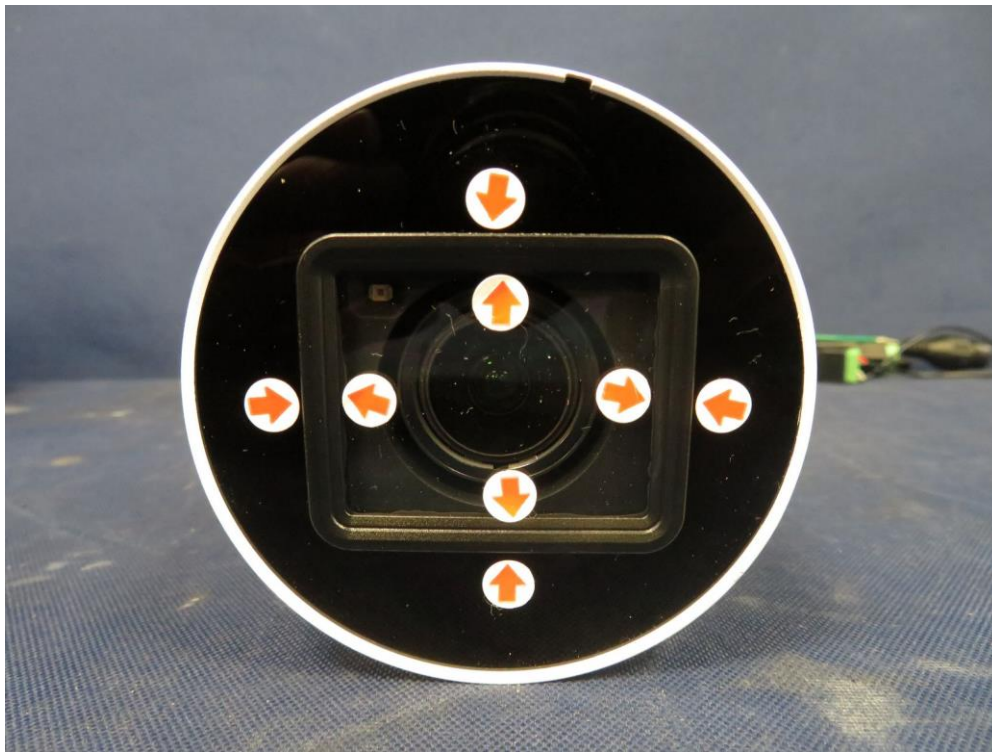

Test dot : (Air DISCHARGE)



Test dot : (CONTACT DISCHARGE)



Test dot : (CONTACT DISCHARGE)



Test dot : (CONTACT DISCHARGE)



Test dot : (CONTACT DISCHARGE)



7. Radiated Susceptibility

7.1. Test Specification

According to EN 50121-4 clause 6.

7.2. Test Setup

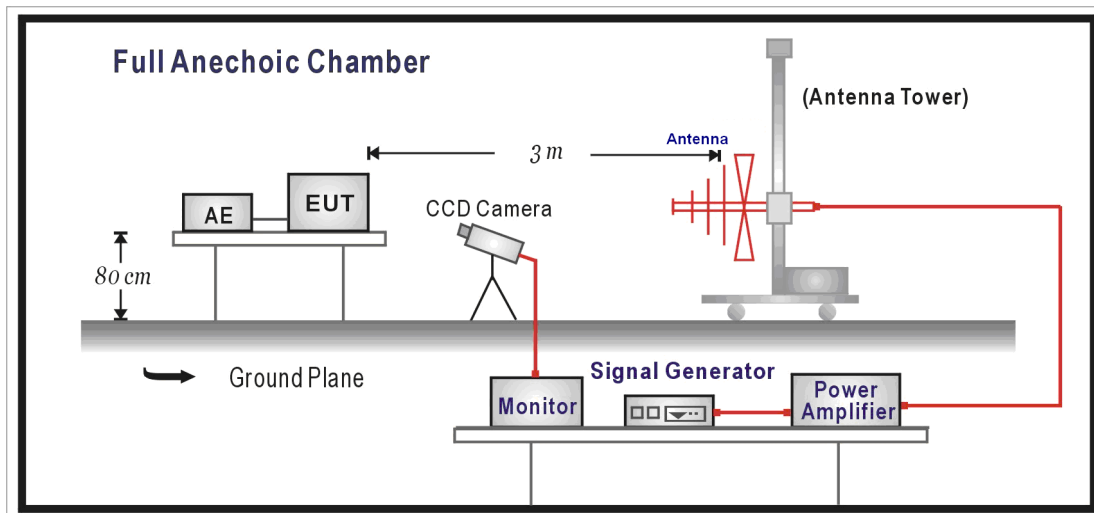

7.3. Limit

Item	Environmental Phenomena	Units	Test Specification	Performance Criteria
Enclosure Port				
Radio-Frequency	Electromagnetic Field	MHz	80-800	A
Amplitude Modulated	V/m(Un-modulated, rms)	% AM (1kHz)	10 80	
Radio-Frequency	Electromagnetic Field	MHz	800-1000	A
Amplitude Modulated	V/m(Un-modulated, rms)	% AM (1kHz)	20 80	
Radio-Frequency	Electromagnetic Field	MHz	1400-2000	A
Amplitude Modulated	V/m(Un-modulated, rms)	% AM (1kHz)	10 80	
Radio-Frequency	Electromagnetic Field	MHz	2000-2700	A
Amplitude Modulated	V/m(Un-modulated, rms)	% AM (1kHz)	5 80	
Radio-Frequency	Electromagnetic Field	MHz	5100-6000	A
Amplitude Modulated	V/m(Un-modulated, rms)	% AM (1kHz)	3 80	

7.4. Test Procedure

According to EN 61000-4-3

The EUT and load, which are placed on a table that is 0.8 meter above ground, are placed with one coincident with the calibration plane such that the distance from antenna to the EUT was 3 meters.

Both horizontal and vertical polarization of the antenna and four sides of the EUT are set on measurement.

In order to judge the EUT performance, a Network Camera camera is used to monitor EUT screen.

All the scanning conditions are as follows:

Condition of Test	Remarks
1. Field Strength	5, 10, 20V/m
2. Radiated Signal	AM 80% Modulated with 1kHz
3. Scanning Frequency	80MHz-800MHz for 10V/m 800MHz-1000MHz for 20V/m 1400MHz-2000MHz for 10V/m 2000MHz-2700MHz for 5V/m 5100MHz-6000MHz for 3V/m
4 Dwell Time	3 Seconds
5. Frequency step size Δf :	1%
6. The rate of Swept of Frequency	1.5×10^{-3} decades/s

7.5. Deviation from Test Standard

No deviation.

7.6. Test Result

Product	Network Camera		
Test Item	Radiated susceptibility		
Test Mode	Mode 1: IB9387-EHT, Adapter		
Date of Test	2019/05/12	Test Site	Chamber 9

Frequency (MHz)	Position (Angle)	Polarity (H or V)	Field Strength (V/m)	Required Criteria	Complied To Criteria (A,B,C)	Results
80-800	0°	H	10	A	A	PASS
80-800	0°	V	10	A	A	PASS
80-800	90°	H	10	A	A	PASS
80-800	90°	V	10	A	A	PASS
80-800	180°	H	10	A	A	PASS
80-800	180°	V	10	A	A	PASS
80-800	270°	H	10	A	A	PASS
80-800	270°	V	10	A	A	PASS
800-1000	0°	H	20	A	A	PASS
800-1000	0°	V	20	A	A	PASS
800-1000	90°	H	20	A	A	PASS
800-1000	90°	V	20	A	A	PASS
800-1000	180°	H	20	A	A	PASS
800-1000	180°	V	20	A	A	PASS
800-1000	270°	H	20	A	A	PASS
800-1000	270°	V	20	A	A	PASS
1400-2000	0°	H	10	A	A	PASS
1400-2000	0°	V	10	A	A	PASS
1400-2000	90°	H	10	A	A	PASS
1400-2000	90°	V	10	A	A	PASS
1400-2000	180°	H	10	A	A	PASS
1400-2000	180°	V	10	A	A	PASS
1400-2000	270°	H	10	A	A	PASS
1400-2000	270°	V	10	A	A	PASS
2000-2700	0°	H	5	A	A	PASS
2000-2700	0°	V	5	A	A	PASS
2000-2700	90°	H	5	A	A	PASS
2000-2700	90°	V	5	A	A	PASS
2000-2700	180°	H	5	A	A	PASS
2000-2700	180°	V	5	A	A	PASS
2000-2700	270°	H	5	A	A	PASS
2000-2700	270°	V	5	A	A	PASS
5100-6000	0°	H	3	A	A	PASS
5100-6000	0°	V	3	A	A	PASS
5100-6000	90°	H	3	A	A	PASS
5100-6000	90°	V	3	A	A	PASS
5100-6000	180°	H	3	A	A	PASS
5100-6000	180°	V	3	A	A	PASS
5100-6000	270°	H	3	A	A	PASS
5100-6000	270°	V	3	A	A	PASS

Note:

The testing performed is from lowest level up to the highest level as required by standard, but only highest level is shown on the report.

- Meet criteria A: Operate as intended during and after the test
- Meet criteria B: Operate as intended after the test
- Meet criteria C: Loss/Error of function
- Additional Information
 - There was no observable degradation in performance.
 - EUT stopped operation and could / could not be reset by operator at _____ V/m at frequency _____MHz.
- No false alarms or other malfunctions were observed during or after the test.

Product	Network Camera		
Test Item	Radiated susceptibility		
Test Mode	Mode 2: IB9387-EHT, PoE		
Date of Test	2019/05/12	Test Site	Chamber 9

Frequency (MHz)	Position (Angle)	Polarity (H or V)	Field Strength (V/m)	Required Criteria	Complied To Criteria (A,B,C)	Results
80-800	0°	H	10	A	A	PASS
80-800	0°	V	10	A	A	PASS
80-800	90°	H	10	A	A	PASS
80-800	90°	V	10	A	A	PASS
80-800	180°	H	10	A	A	PASS
80-800	180°	V	10	A	A	PASS
80-800	270°	H	10	A	A	PASS
80-800	270°	V	10	A	A	PASS
800-1000	0°	H	20	A	A	PASS
800-1000	0°	V	20	A	A	PASS
800-1000	90°	H	20	A	A	PASS
800-1000	90°	V	20	A	A	PASS
800-1000	180°	H	20	A	A	PASS
800-1000	180°	V	20	A	A	PASS
800-1000	270°	H	20	A	A	PASS
800-1000	270°	V	20	A	A	PASS
1400-2000	0°	H	10	A	A	PASS
1400-2000	0°	V	10	A	A	PASS
1400-2000	90°	H	10	A	A	PASS
1400-2000	90°	V	10	A	A	PASS
1400-2000	180°	H	10	A	A	PASS
1400-2000	180°	V	10	A	A	PASS
1400-2000	270°	H	10	A	A	PASS
1400-2000	270°	V	10	A	A	PASS
2000-2700	0°	H	5	A	A	PASS
2000-2700	0°	V	5	A	A	PASS
2000-2700	90°	H	5	A	A	PASS
2000-2700	90°	V	5	A	A	PASS
2000-2700	180°	H	5	A	A	PASS
2000-2700	180°	V	5	A	A	PASS
2000-2700	270°	H	5	A	A	PASS
2000-2700	270°	V	5	A	A	PASS
5100-6000	0°	H	3	A	A	PASS
5100-6000	0°	V	3	A	A	PASS
5100-6000	90°	H	3	A	A	PASS
5100-6000	90°	V	3	A	A	PASS
5100-6000	180°	H	3	A	A	PASS
5100-6000	180°	V	3	A	A	PASS
5100-6000	270°	H	3	A	A	PASS
5100-6000	270°	V	3	A	A	PASS

Note:

The testing performed is from lowest level up to the highest level as required by standard, but only highest level is shown on the report.

- Meet criteria A: Operate as intended during and after the test
- Meet criteria B: Operate as intended after the test
- Meet criteria C: Loss/Error of function
- Additional Information
 - There was no observable degradation in performance.
 - EUT stopped operation and could / could not be reset by operator at _____ V/m at frequency _____MHz.
- No false alarms or other malfunctions were observed during or after the test.

7.7. Test Photograph

Test Mode : Mode 1: IB9387-EHT, Adapter

Description : Radiated Susceptibility Test Setup

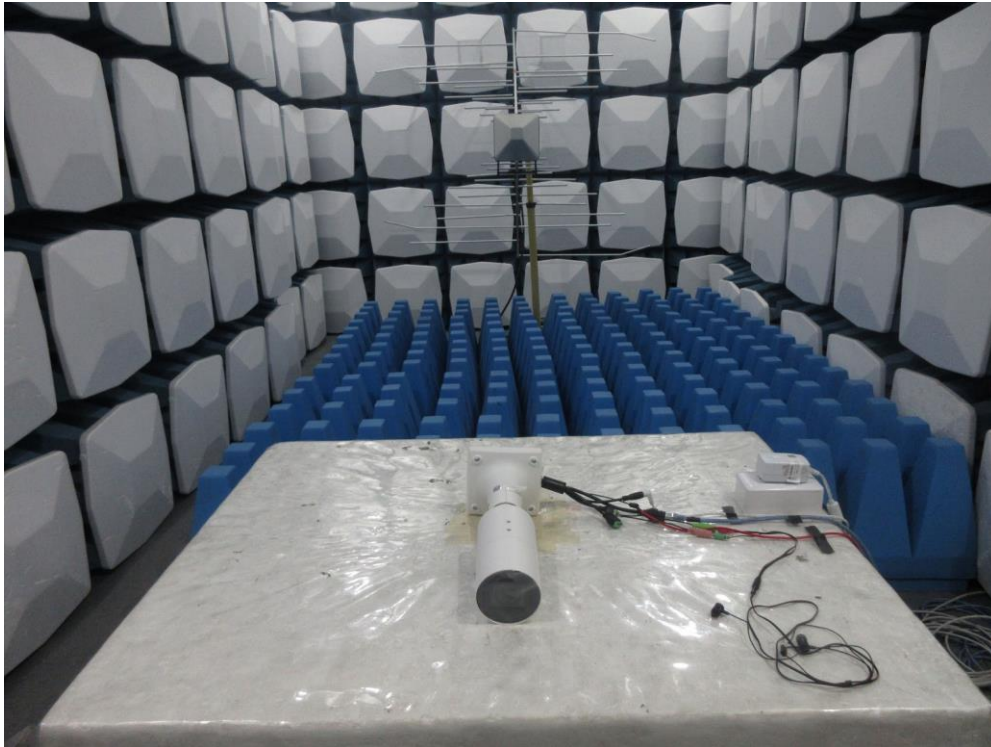

Test Mode : Mode 1: IB9387-EHT, Adapter

Description : Radiated Susceptibility Test Setup

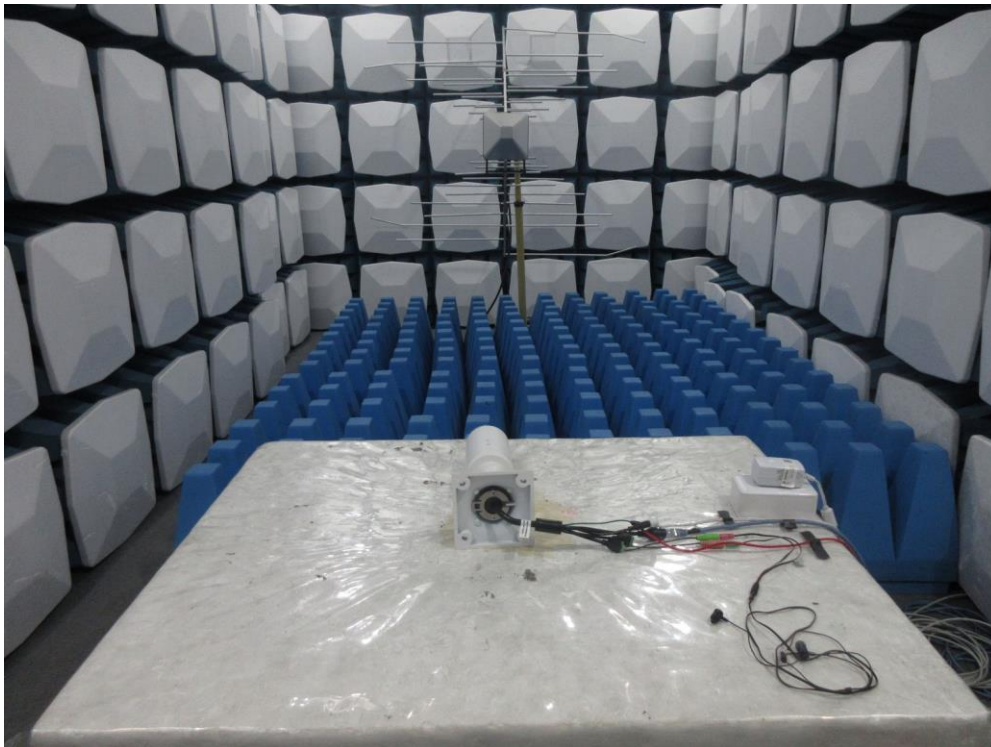

Test Mode : Mode 1: IB9387-EHT, Adapter

Description : Radiated Susceptibility Test Setup

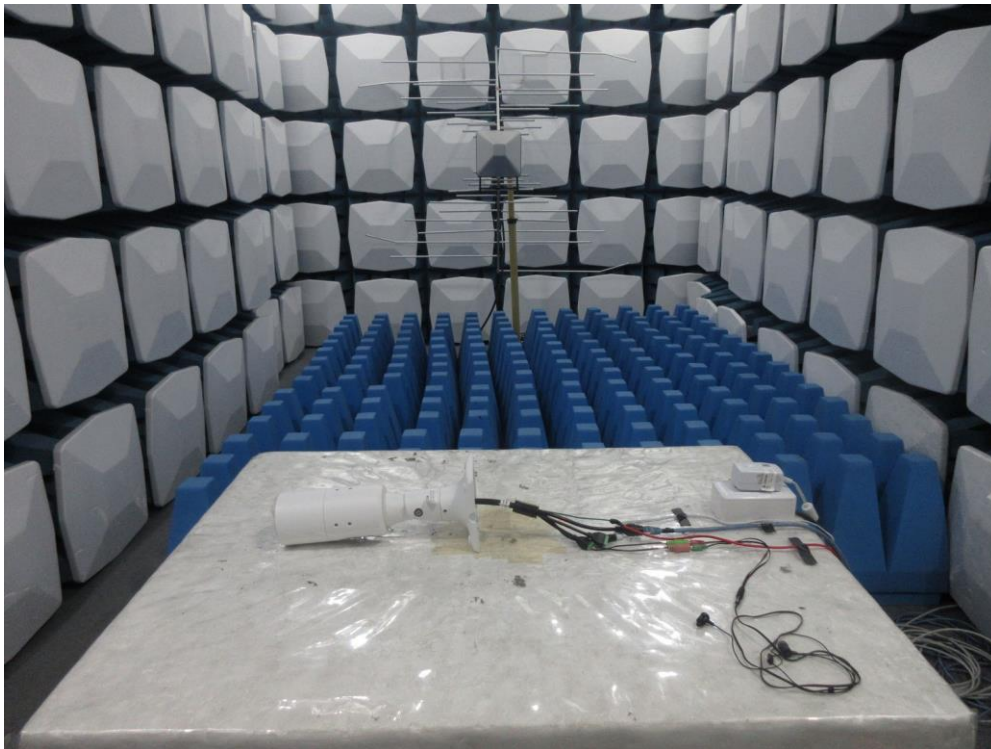

Test Mode : Mode 1: IB9387-EHT, Adapter

Description : Radiated Susceptibility Test Setup

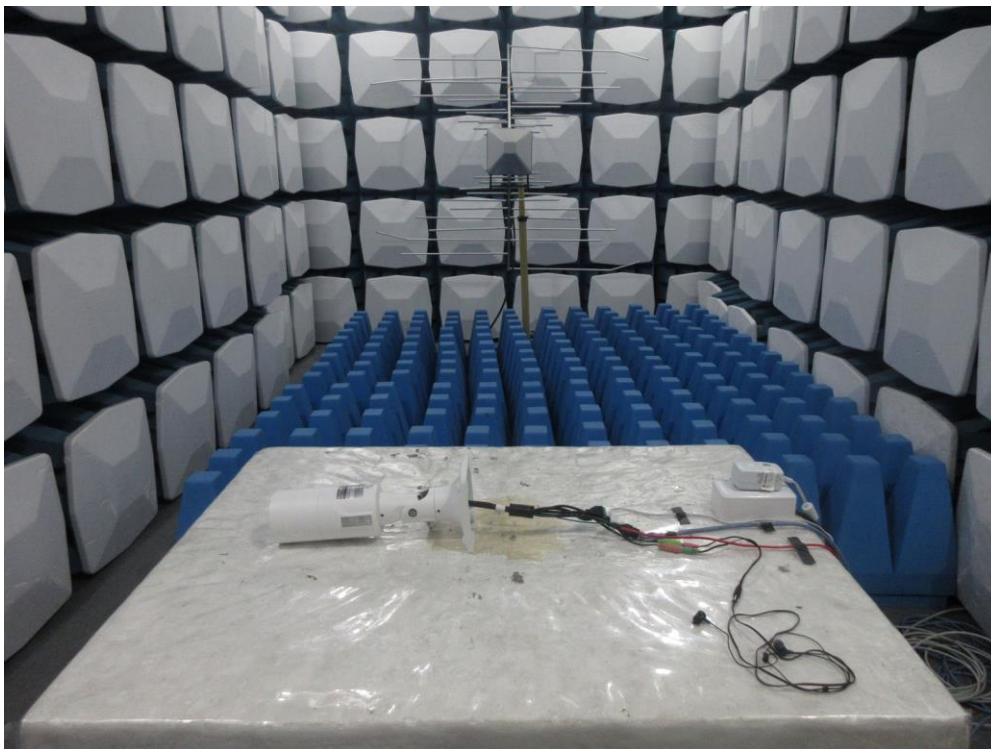

Test Mode : Mode 1: IB9387-EHT, Adapter
Description : Radiated Susceptibility Test Setup

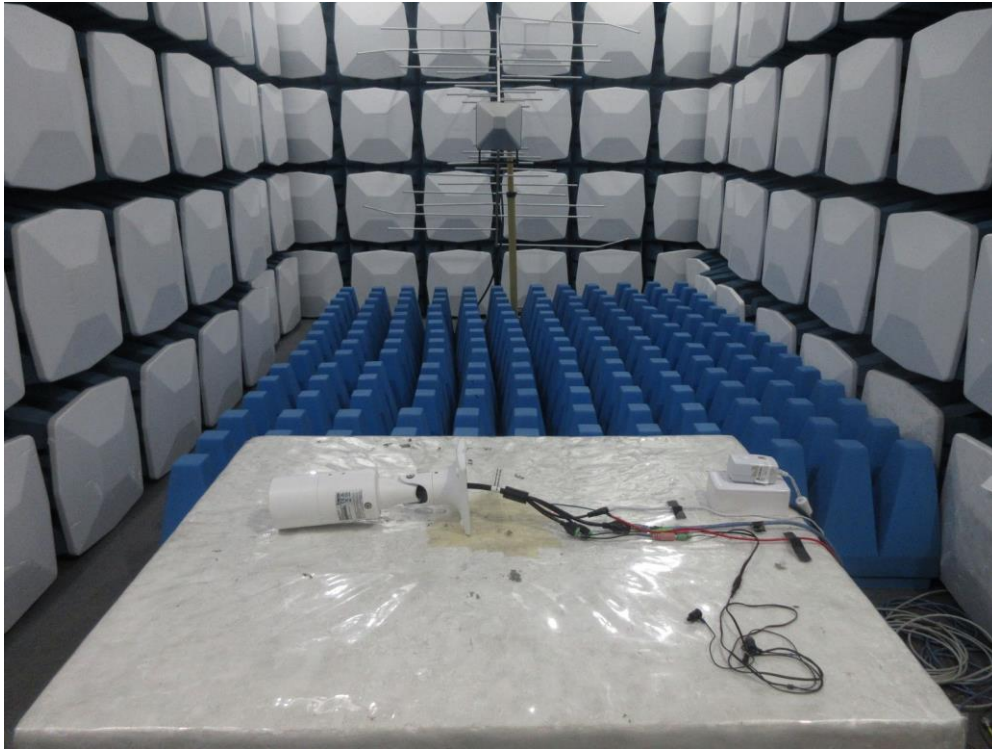

Test Mode : Mode 1: IB9387-EHT, Adapter
Description : Radiated Susceptibility Test Setup

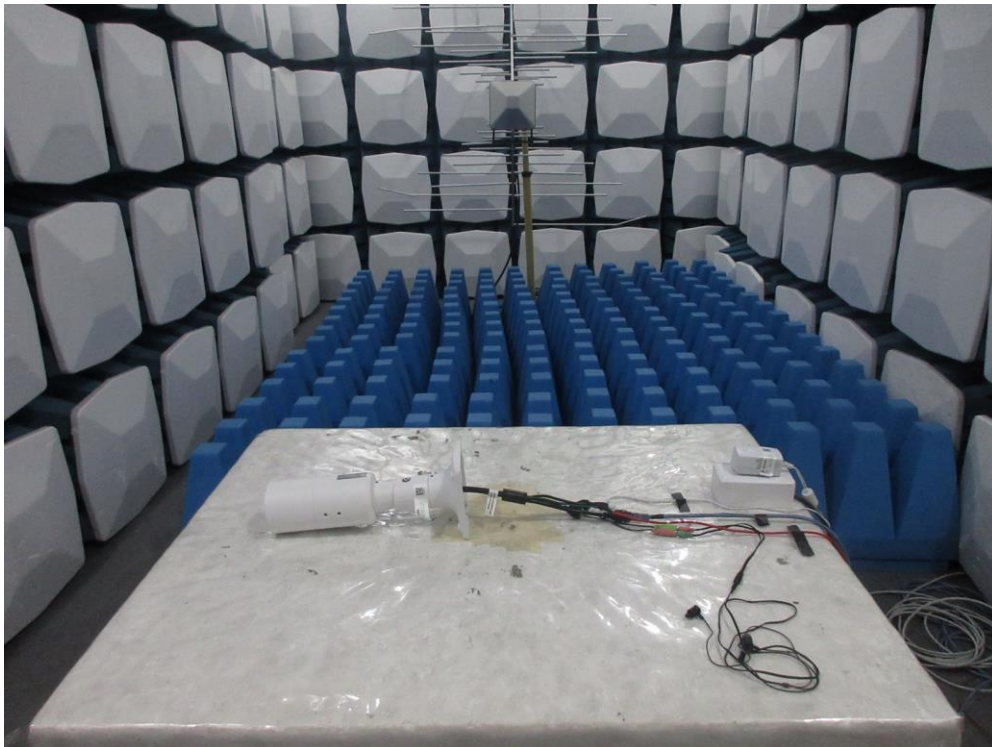

Test Mode : Mode 2: IB9387-EHT, PoE

Description : Radiated Susceptibility Test Setup

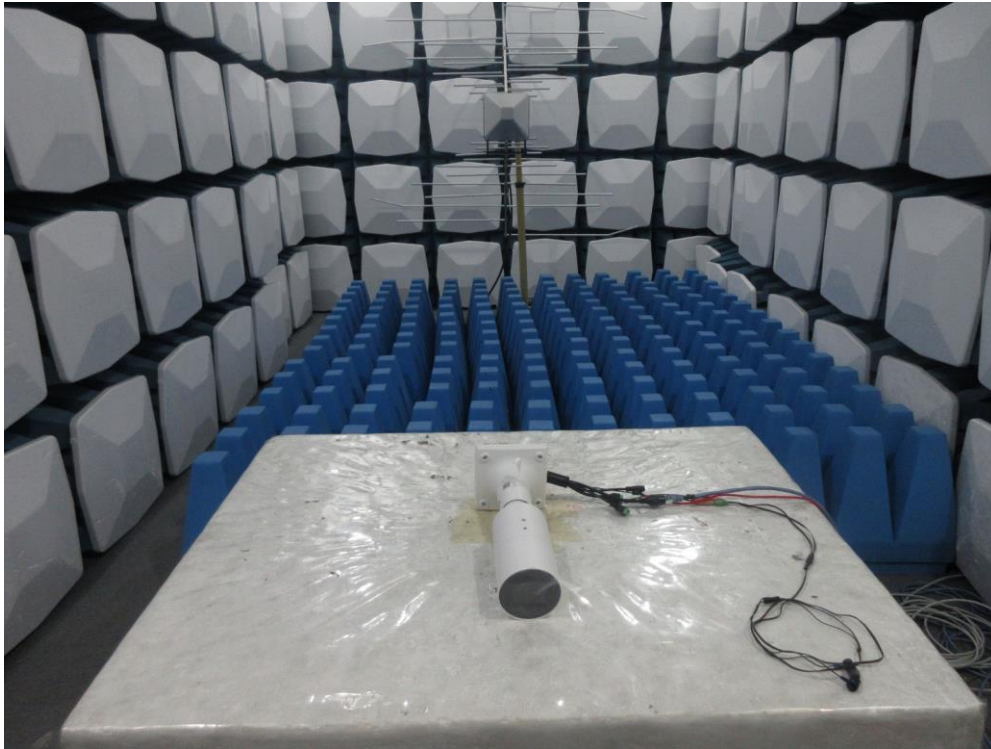

Test Mode : Mode 2: IB9387-EHT, PoE

Description : Radiated Susceptibility Test Setup

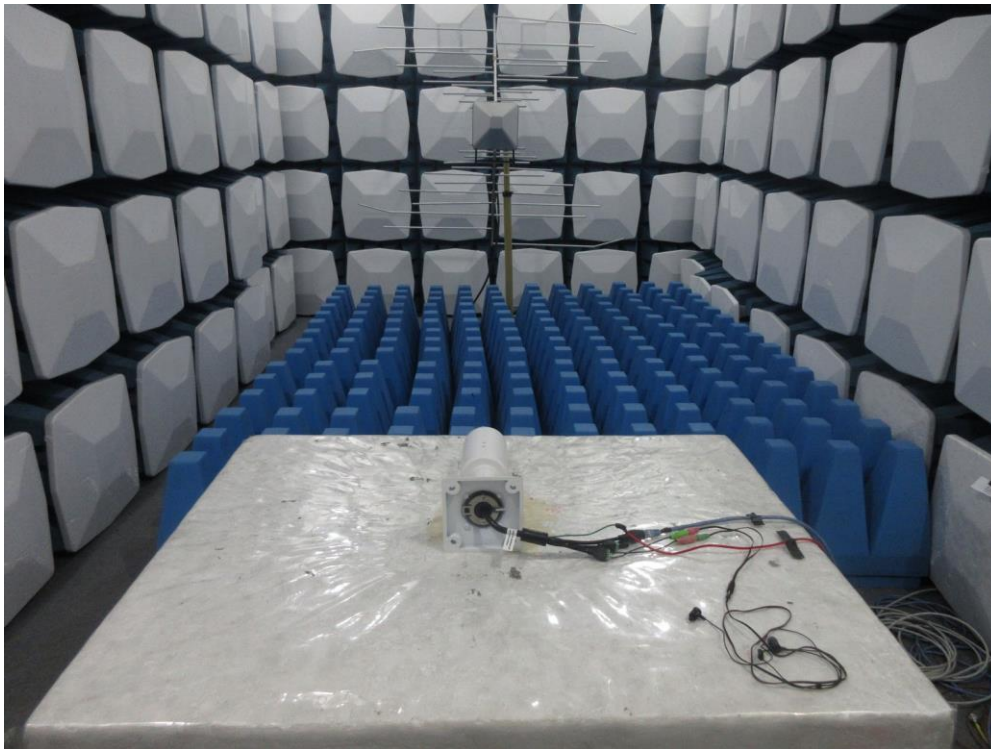

Test Mode : Mode 2: IB9387-EHT, PoE

Description : Radiated Susceptibility Test Setup

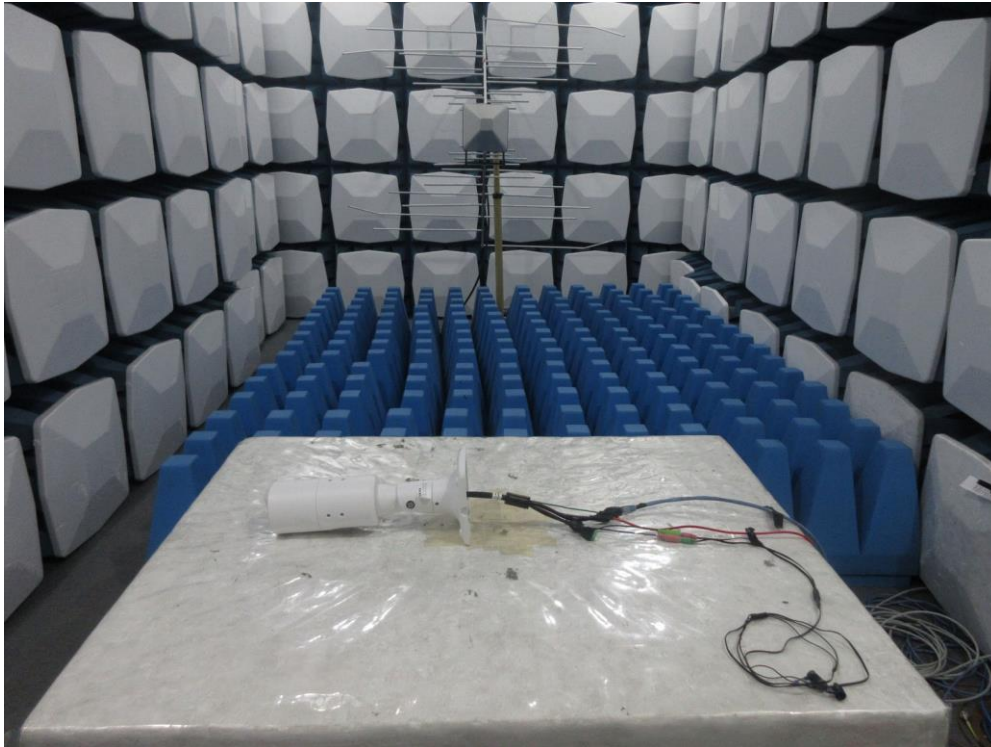

Test Mode : Mode 2: IB9387-EHT, PoE

Description : Radiated Susceptibility Test Setup

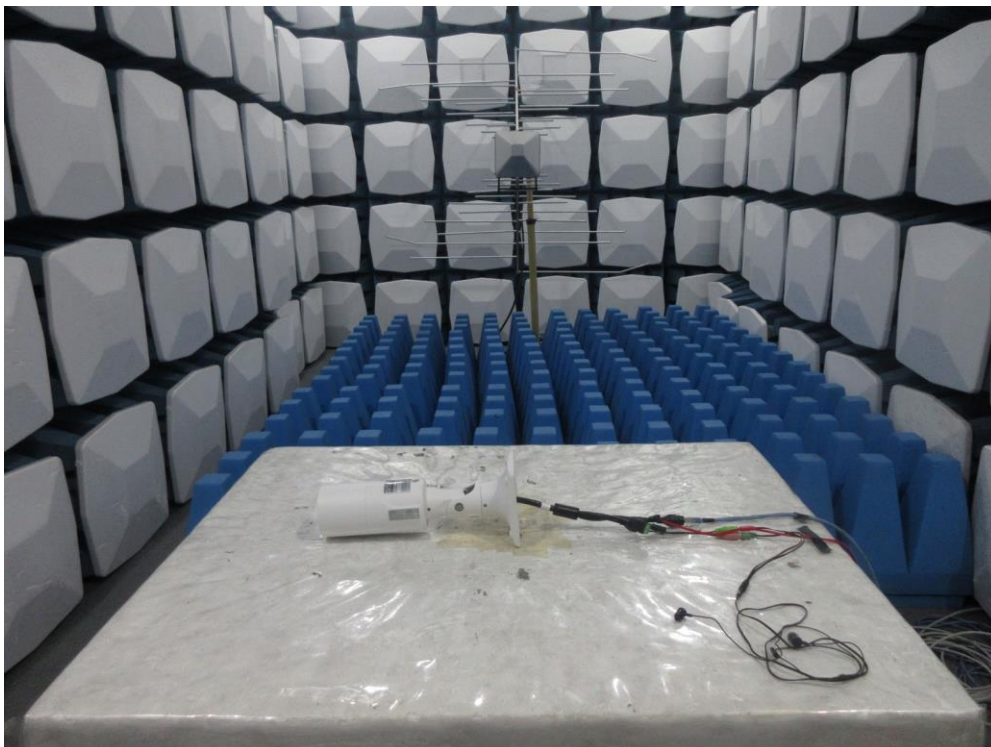

Test Mode : Mode 2: IB9387-EHT, PoE

Description : Radiated Susceptibility Test Setup

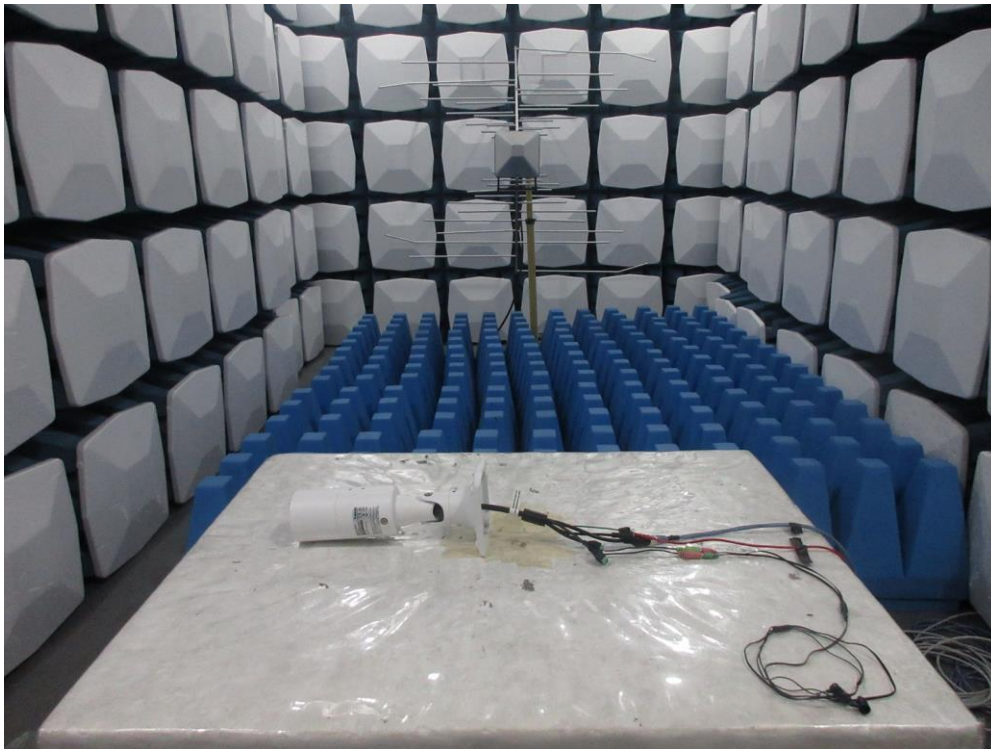

Test Mode : Mode 2: IB9387-EHT, PoE

Description : Radiated Susceptibility Test Setup

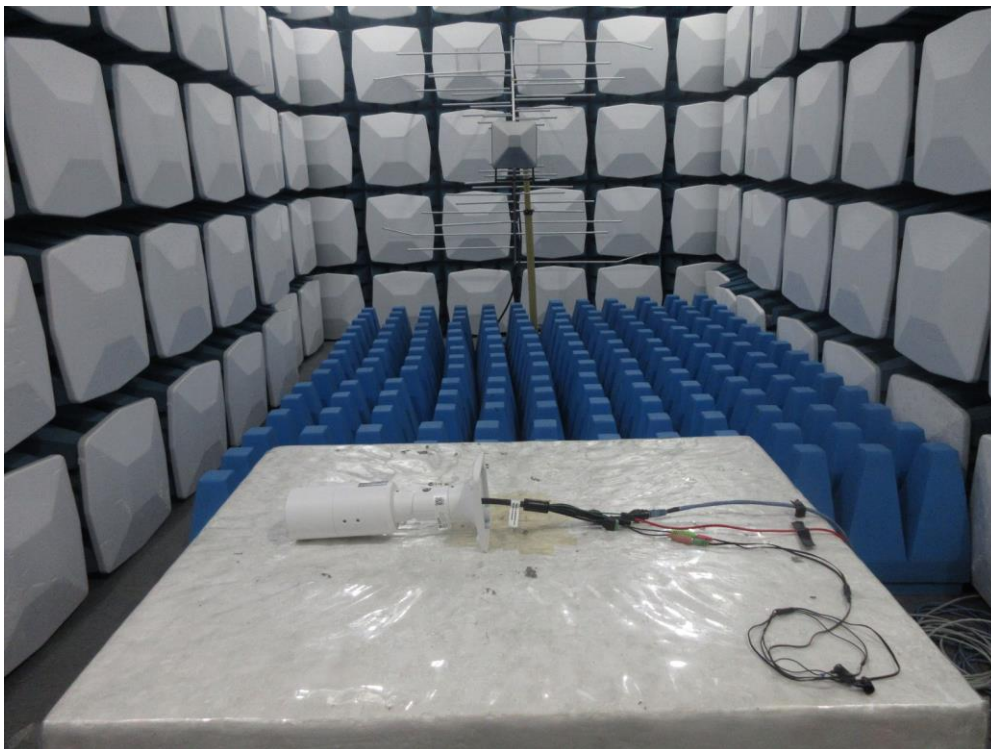

8. Electrical Fast Transient/Burst

8.1. Test Specification

According to EN 50121-4 clause 6.

8.2. Test Setup

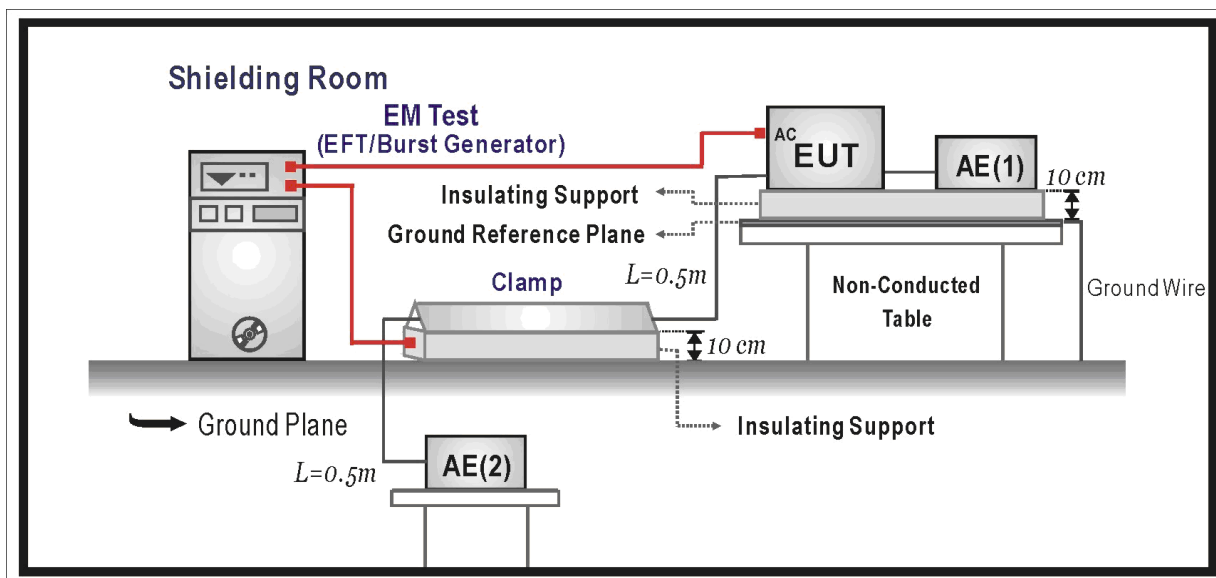

8.3. Limit

Item	Environmental Phenomena	Units	Test Specificatio	Performance Criteria
Signal and Telecommunication Ports				
	Fast Transients Common Mode	kV (Peak) Tr/Th ns Rep. Frequency kHz	+2 5/50 5	A
Input DC Power Ports				
	Fast Transients Common Mode	kV (Peak) Tr/Th ns Rep. Frequency kHz	+2 5/50 5	A
Input AC Power Ports				
	Fast Transients Common Mode	kV (Peak) Tr/Th ns Rep. Frequency kHz	+2 5/50 5	A

8.4. Test Procedure

According to EN 61000-4-4.

The EUT is placed on a table that is 0.8 meter height. A ground reference plane is placed on the table, and uses a 0.1m insulation between the EUT and ground reference plane.

The minimum area of the ground reference plane is 1m*1m, and 0.65mm thick min, and projected beyond the EUT by at least 0.1m on all sides.

Test on I/O and communication ports:

The EFT interference signal is through a coupling clamp device couples to the signal and control lines of the EUT with burst noise for 1 minute.

Test on power supply ports:

The EUT is connected to the power mains through a coupling device that directly couples the EFT/B interference signal.

Each of the Line and Neutral conductors is impressed with burst noise for 1 minute.

The length of the signal and power lines between the coupling device and the EUT is 0.5m.

8.5. Deviation from Test Standard

No deviation

8.6. Test Result

Product	Network Camera		
Test Item	Electrical fast transient/burst		
Test Mode	Mode 1: IB9387-EHT, Adapter		
Date of Test	2019/05/12	Test Site	No.6 Shielded Room

Inject Line	Polarity	Voltage kV	Inject Time (Second)	Inject Method	Required Criteria	Complied to Criteria	Result
L	±	2kV	60	Direct	A	A	PASS
N	±	2kV	60	Direct	A	A	PASS
L-N	±	2kV	60	Direct	A	A	PASS
LAN	±	2kV	60	Clamp	A	A	PASS

Note:

The testing performed is from lowest level up to the highest level as required by standard, but only highest level is shown on the report.

- Meet criteria A : Operate as intended during and after the test
- Meet criteria B : Operate as intended after the test
- Meet criteria C : Loss/Error of function
- Additional Information
 - EUT stopped operation and could / could not be reset by operator at _____ kV of Line _____.
- No false alarms or other malfunctions were observed during or after the test.

Product	Network Camera		
Test Item	Electrical fast transient/burst		
Test Mode	Mode 2: IB9387-EHT, PoE		
Date of Test	2019/05/12	Test Site	No.6 Shielded Room

Inject Line	Polarity	Voltage kV	Inject Time (Second)	Inject Method	Required Criteria	Complied to Criteria	Result
LAN	±	2kV	60	Clamp	A	A	PASS

Note:

The testing performed is from lowest level up to the highest level as required by standard, but only highest level is shown on the report.

- Meet criteria A : Operate as intended during and after the test
- Meet criteria B : Operate as intended after the test
- Meet criteria C : Loss/Error of function
- Additional Information
 - EUT stopped operation and could / could not be reset by operator at _____ kV of Line _____.
- No false alarms or other malfunctions were observed during or after the test.

8.7. Test Photograph

Test Mode : Mode 1: IB9387-EHT, Adapter

Description : EFT/B Test Setup



Test Mode : Mode 1: IB9387-EHT, Adapter

Description : EFT/B Test Setup - Clamp



Test Mode : Mode 2: IB9387-EHT, PoE

Description : EFT/B Test Setup - Clamp



9. Surge

9.1. Test Specification

According to EN 50121-4 clause 6.

9.2. Test Setup

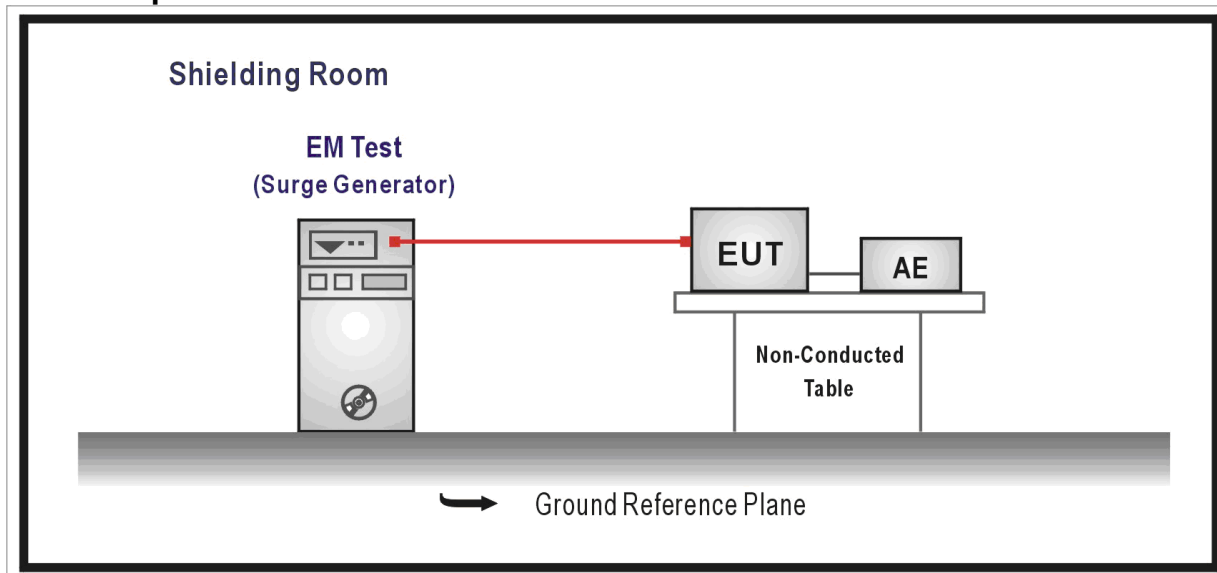

9.3. Limit

Item	Environmental Phenomena	Units	Test Specification	Performance Criteria
Signal Ports and Telecommunication Ports(See 1) and 2))				
	Surges	Tr/Th us	1.2/50 (8/20)	B
	Line to Line	kV	± 1	
	Line to Ground	kV	± 2	
	Output Impedance Ω		42	
	Coupling Capacitance μF		0.5	
Input DC Power Ports				
	Surges	Tr/Th us	1.2/50 (8/20)	B
	Line to Line	kV	± 1	
	Line to Ground	KV	± 2	
	Output Impedance Ω		42	
	Coupling Capacitance μF		0.5	
Input AC Power Ports				
	Surges	Tr/Th us	1.2/50 (8/20)	B
	Line to Line	kV	± 1	
	Line to Ground	kV	± 2	

Notes:

- 1) For telecommunication ports and other ports intended for connection to highly balanced pairs, a line to line test is not required.
- 2) Ports directly connected to power ports or to the (public) low voltage network are classified as power ports also.

9.4. Test Procedure

According to EN 61000-4-5.

The EUT and its load are placed on a table that is 0.8 meter above a metal ground plane measured 1m*1m min. and 0.65mm thick min. And projected beyond the EUT by at least 0.1m on all sides. The length of power cord between the coupling device and the EUT shall be 2m or less.

For Input and Output AC Power or DC Input and DC Output Power Ports:

The EUT is connected to the power mains through a coupling device that directly couples the Surge interference signal.

The surge noise shall be applied synchronized to the voltage phase at 0⁰, 90⁰, 180⁰, 270⁰ and the peak value of the a.c. voltage wave. (Positive and negative)

Each of Line-Earth and Line-Line is impressed with a sequence of five surge voltages with interval of 1 min.

9.5. Deviation from Test Standard

No deviation.

9.6. Test Result

Product	Network Camera		
Test Item	Surge		
Test Mode	Mode 1: IB9387-EHT, Adapter		
Date of Test	2019/05/17	Test Site	No.6 Shielded Room

Inject Line	Polarity	Voltage kV	Angle	Time Interval (Second)	Inject Method	Required Criteria	Complied to Criteria	Result
L-N	±	1kV	0	60	Direct	B	A	PASS
L-N	±	1kV	90	60	Direct	B	A	PASS
L-N	±	1kV	180	60	Direct	B	A	PASS
L-N	±	1kV	270	60	Direct	B	A	PASS
LAN (Line to Ground)	±	4kV	--	60	Direct	B	B	PASS

Note:

The testing performed is from lowest level up to the highest level as required by standard, but only highest level is shown on the report.

- Meet criteria A : Operate as intended during and after the test
- Meet criteria B : Operate as intended after the test
- Meet criteria C : Loss/Error of function
- Additional Information
 - EUT stopped operation and could / could not be reset by operator at _____ kV of Line _____.
- No false alarms or other malfunctions were observed during or after the test.

Product	Network Camera		
Test Item	Surge		
Test Mode	Mode 2: IB9387-EHT, PoE		
Date of Test	2019/05/17	Test Site	No.6 Shielded Room

Inject Line	Polarity	Voltage kV	Angle	Time Interval (Second)	Inject Method	Required Criteria	Complied to Criteria	Result
LAN (Line to Ground)	±	4kV	--	60	Direct	B	B	PASS

Note:

The testing performed is from lowest level up to the highest level as required by standard, but only highest level is shown on the report.

- Meet criteria A : Operate as intended during and after the test
- Meet criteria B : Operate as intended after the test
- Meet criteria C : Loss/Error of function
- Additional Information
 - EUT stopped operation and could / could not be reset by operator at _____ kV of Line _____.
- No false alarms or other malfunctions were observed during or after the test.

9.7. Test Photograph

Test Mode : Mode 1: IB9387-EHT, Adapter

Description : SURGE Test Setup



Test Mode : Mode 2: IB9387-EHT, PoE

Description : SURGE Test Setup



10. Conducted Susceptibility

10.1. Test Specification

According to EN 50121-4 clause 6.

10.2. Test Setup

CDN Inject Method

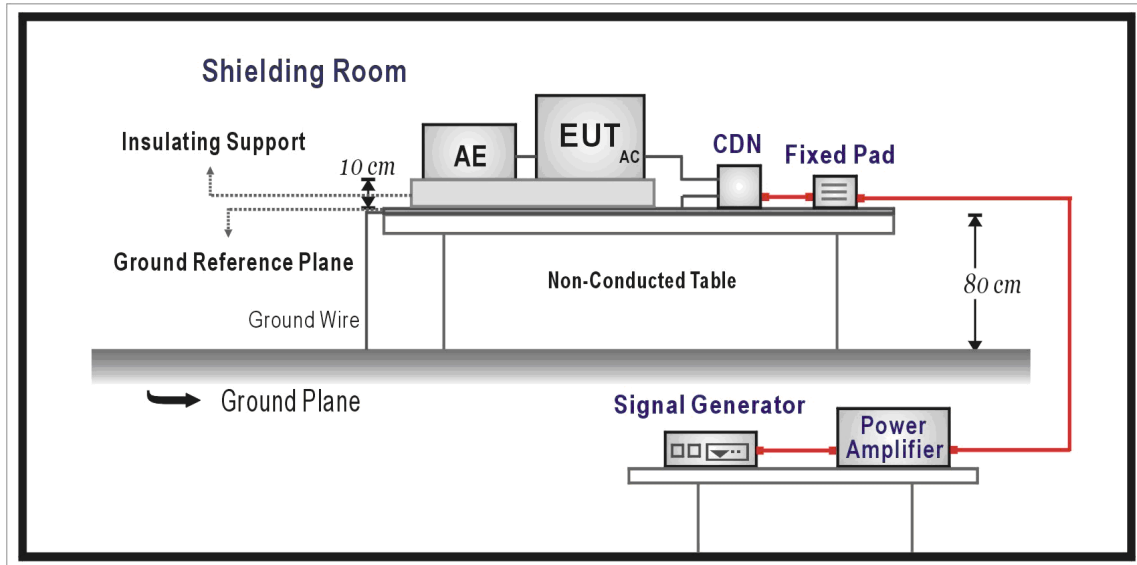

EM Clamp Inject Method

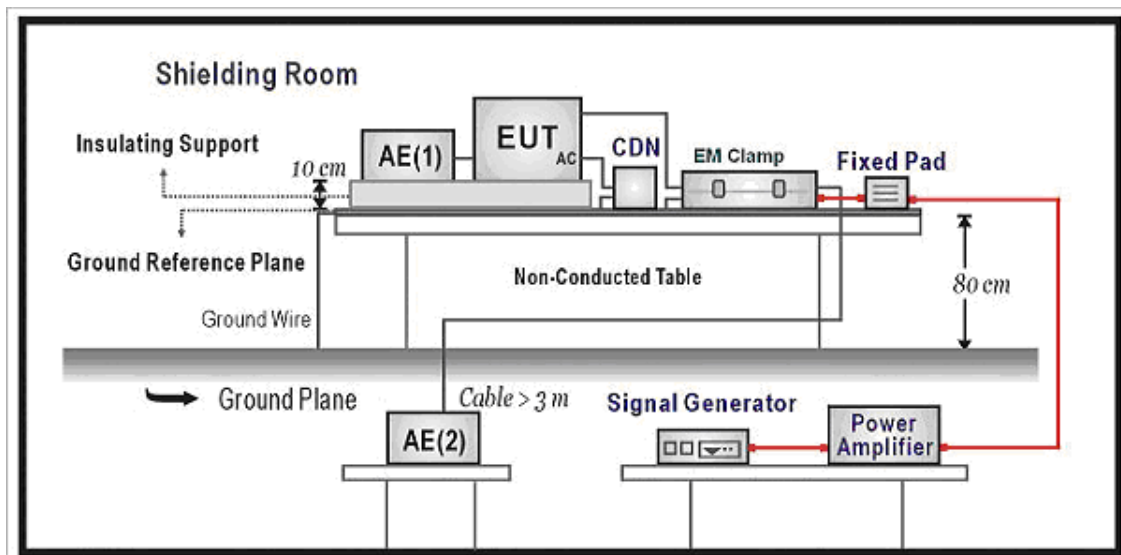

10.3. Limit

Item	Environmental Phenomena	Units	Test Specification	Performance Criteria
Signal Ports and Telecommunication Ports				
	Radio-Frequency Continuous Conducted	MHz V (rms, Un-modulated) % AM (1kHz)	0.15-80 10 80	A
Input DC Power Ports				
	Radio-Frequency Continuous Conducted	MHz V (rms, Un-modulated) % AM (1kHz)	0.15-80 10 80	A
Input AC Power Ports				
	Radio-Frequency Continuous Conducted	MHz V (rms, Un-modulated) % AM (1kHz)	0.15-80 10 80	A

10.4. Test Procedure

According to EN 61000-4-6.

The EUT are placed on a table that is 0.8 meter height, and a Ground reference plane on the table, EUT are placed upon table and use a 10cm insulation between the EUT and Ground reference plane.

For Signal Ports and Telecommunication Ports

The disturbance signal is through a coupling and decoupling networks (CDN) or EM-clamp device couples to the signal and Telecommunication lines of the EUT.

For Input DC and AC Power Ports

The EUT is connected to the power mains through a coupling and decoupling networks for power supply lines. And directly couples the disturbances signal into EUT.

Used CDN-M2 for two wires or CDN-M3 for three wires.

All the scanning conditions are as follows:

Condition of Test	Remarks
1. Field Strength	140dB μ V(10V) Level 3
2. Radiated Signal	AM 80% Modulated with 1kHz
3. Scanning Frequency	0.15MHz – 80MHz
4. Dwell Time	3 Seconds
5. Frequency step size Δf :	1%

10.5. Deviation from Test Standard

No deviation.

10.6. Test Result

Product	Network Camera		
Test Item	Conducted susceptibility		
Test Mode	Mode 1: IB9387-EHT, Adapter		
Date of Test	2019/05/09	Test Site	No.6 Shielded Room

Frequency Range (MHz)	Voltage Applied dBuV(V)	Inject Method	Tested Port of EUT	Required Criteria	Performance Criteria Complied To	Result
0.15~80	10V	CDN	AC IN	A	A	PASS
0.15~80	10V	CDN	LAN	A	A	PASS

Note:

The testing performed is from lowest level up to the highest level as required by standard, but only highest level is shown on the report.

- Meet criteria A : Operate as intended during and after the test
- Meet criteria B : Operate as intended after the test
- Meet criteria C : Loss/Error of function
- Additional Information
 - EUT stopped operation and could / could not be reset by operator at _____ dBuV(V) at frequency _____MHz.
 - No false alarms or other malfunctions were observed during or after the test. The acceptance criteria were met, and the EUT passed the test.

Product	Network Camera		
Test Item	Conducted susceptibility		
Test Mode	Mode 2: IB9387-EHT, PoE		
Date of Test	2019/05/09	Test Site	No.6 Shielded Room

Frequency Range (MHz)	Voltage Applied dBuV(V)	Inject Method	Tested Port of EUT	Required Criteria	Performance Criteria Complied To	Result
0.15~80	10V	CDN	LAN	A	A	PASS

Note:

The testing performed is from lowest level up to the highest level as required by standard, but only highest level is shown on the report.

- Meet criteria A : Operate as intended during and after the test
- Meet criteria B : Operate as intended after the test
- Meet criteria C : Loss/Error of function
- Additional Information
 - EUT stopped operation and could / could not be reset by operator at _____ dBuV(V) at frequency _____MHz.
 - No false alarms or other malfunctions were observed during or after the test. The acceptance criteria were met, and the EUT passed the test.

10.7. Test Photograph

Test Mode : Mode 1: IB9387-EHT, Adapter

Description : Conducted Susceptibility Test Setup



Test Mode : Mode 1: IB9387-EHT, Adapter

Description : Conducted Susceptibility Test Setup - CDN



Test Mode : Mode 2: IB9387-EHT, PoE

Description : Conducted Susceptibility Test Setup - CDN



11. Power Frequency Magnetic Field

11.1. Test Specification

According to EN 50121-4 clause 6.

11.2. Test Setup

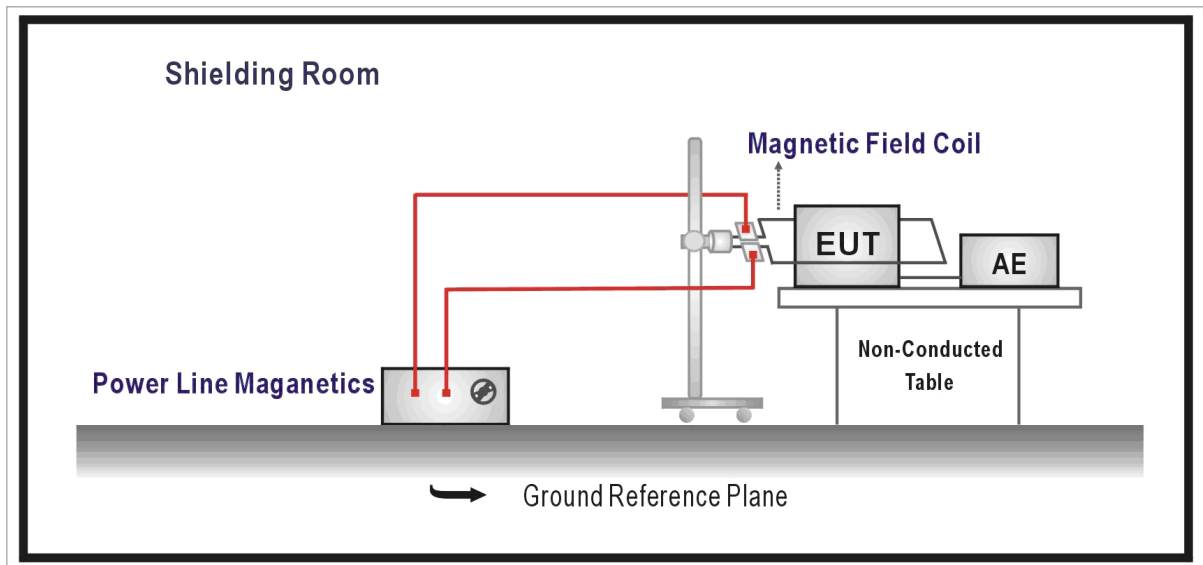

11.3. Limit

Item	Environmental Phenomena	Units	Test Specification	Performance Criteria
Enclosure Port				
	Power-Frequency Magnetic Field	Hz	16.7	A
		Hz	50	
		Hz	0 d.c	
		A/m (r.m.s.)	100 a.c. systems	
		A/m (r.m.s.)	300 d.c. systems	

Note: Test only applies to apparatus containing devices sensitive to magnetic fields, such as Hall elements, electro-dynamic microphones etc.

11.4. Test Procedure

According to EN 61000-4-8.

The EUT and its load are placed on a table which is 0.8 meter above a metal ground plane measured at least 1m*1m min. The test magnetic field shall be placed at central of the induction coil.

The plane of the inductive coil shall then be rotated by 90° in order to expose the EUT to the test field with different orientations(X, Y, Z Orientations) and the same procedure.

11.5. Deviation from Test Standard

No deviation.

11.6. Test Result

Product	Network Camera		
Test Item	Power frequency magnetic field		
Test Mode	Mode 1: IB9387-EHT, Adapter		
Date of Test	2019/05/12	Test Site	No.3 Shielded Room

Polarization	Frequency (Hz)	Inject Time (s)	Magnetic Strength (A/m)	Required Performance Criteria	Performance Criteria Complied To	Test Result
X Orientation	50	60	100	A	A	PASS
Y Orientation	50	60	100	A	A	PASS
Z Orientation	50	60	100	A	A	PASS
X Orientation	16.7	60	100	A	A	PASS
Y Orientation	16.7	60	100	A	A	PASS
Z Orientation	16.7	60	100	A	A	PASS
X Orientation	0	60	300	A	A	PASS
Y Orientation	0	60	300	A	A	PASS
Z Orientation	0	60	300	A	A	PASS

- Meet criteria A: Operate as intended during and after the test
- Meet criteria B: Operate as intended after the test
- Meet criteria C: Loss/Error of function
- Additional Information
 - EUT stopped operation and could / could not be reset by operator at _____ kV of Line _____.
- No false alarms or other malfunctions were observed during or after the test. The acceptance criteria were met, and the EUT passed the test.

Product	Network Camera		
Test Item	Power frequency magnetic field		
Test Mode	Mode 2: IB9387-EHT, PoE		
Date of Test	2019/05/12	Test Site	No.3 Shielded Room

Polarization	Frequency (Hz)	Inject Time (s)	Magnetic Strength (A/m)	Required Performance Criteria	Performance Criteria Complied To	Test Result
X Orientation	50	60	100	A	A	PASS
Y Orientation	50	60	100	A	A	PASS
Z Orientation	50	60	100	A	A	PASS
X Orientation	16.7	60	100	A	A	PASS
Y Orientation	16.7	60	100	A	A	PASS
Z Orientation	16.7	60	100	A	A	PASS
X Orientation	0	60	300	A	A	PASS
Y Orientation	0	60	300	A	A	PASS
Z Orientation	0	60	300	A	A	PASS

- Meet criteria A: Operate as intended during and after the test
- Meet criteria B: Operate as intended after the test
- Meet criteria C: Loss/Error of function
- Additional Information
 - EUT stopped operation and could / could not be reset by operator at _____ kV of Line _____.
- No false alarms or other malfunctions were observed during or after the test. The acceptance criteria were met, and the EUT passed the test.

11.7. Test Photograph

Test Mode : Mode 1: IB9387-EHT, Adapter

Description : Power Frequency Magnetic Field Test Setup

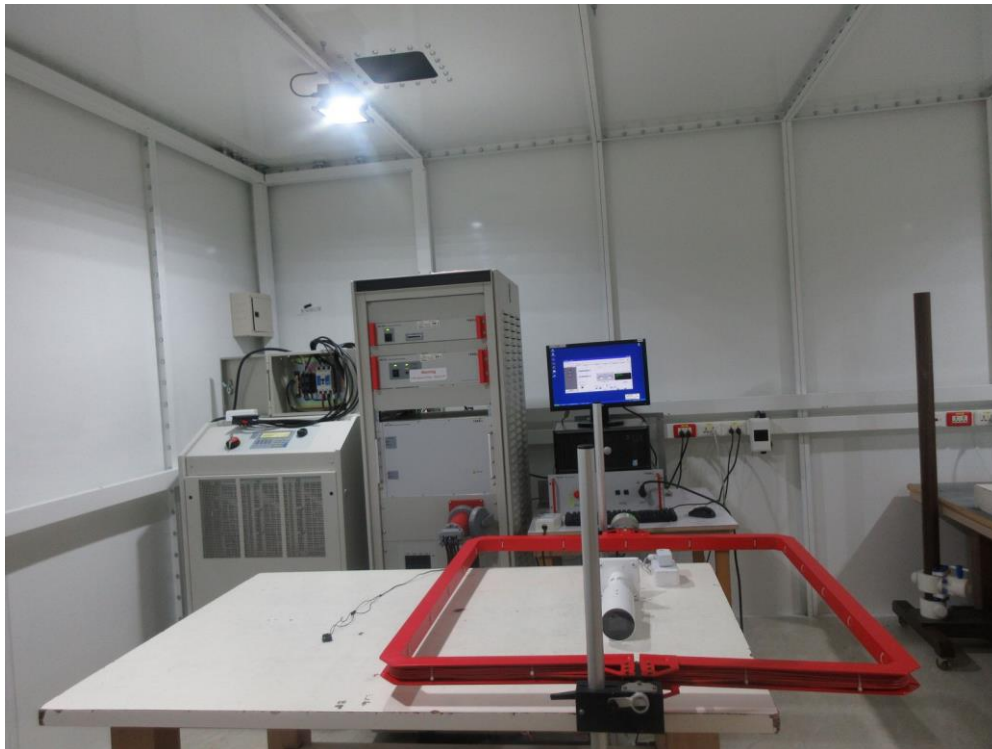

Test Mode : Mode 2: IB9387-EHT, PoE

Description : Power Frequency Magnetic Field Test Setup

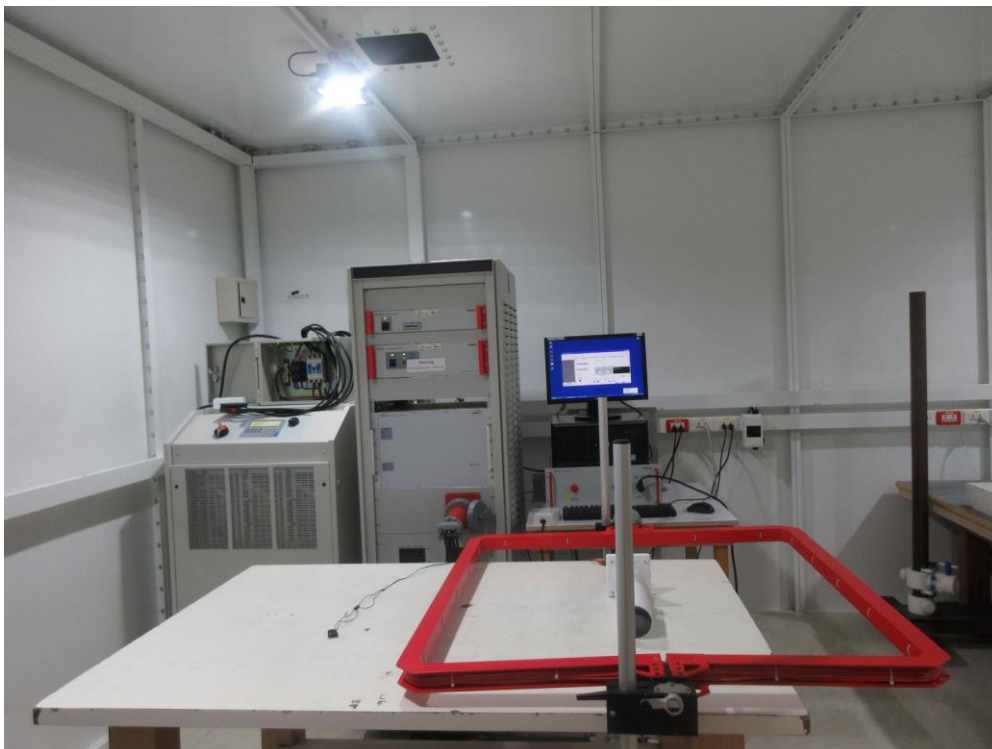

12. Attachment

➤ **EUT Photograph**

(1) EUT Photo



(2) EUT Photo

