

## EN 300 328 RF Test Report

**Report No.:** RE161108D04

**Test Model:** IP8160-W

**Received Date:** Nov. 18, 2016

**Test Date:** Nov. 23 ~ 28, 2016

**Issued Date:** Dec. 6, 2016

**Applicant:** VIVOTEK INC.

**Address:** 6F, No.192, Lien-Cheng Rd., Chung-Ho , New Taipei City, 235, Taiwan,  
R.O.C.

**Issued By:** Bureau Veritas Consumer Products Services (H.K.) Ltd., Taoyuan Branch

**Lab Address:** No. 47-2, 14th Ling, Chia Pau Vil., Lin Kou Dist., New Taipei City, Taiwan  
(R.O.C.)



This report is for your exclusive use. Any copying or replication of this report to or for any other person or entity, or use of our name or trademark, is permitted only with our prior written permission. This report sets forth our findings solely with respect to the test samples identified herein. The results set forth in this report are not indicative or representative of the quality or characteristics of the lot from which a test sample was taken or any similar or identical product unless specifically and expressly noted. Our report includes all of the tests requested by you and the results thereof based upon the information that you provided to us. You have 60 days from date of issuance of this report to notify us of any material error or omission caused by our negligence, provided, however, that such notice shall be in writing and shall specifically address the issue you wish to raise. A failure to raise such issue within the prescribed time shall constitute your unqualified acceptance of the completeness of this report, the tests conducted and the correctness of the report contents. Unless specific mention, the uncertainty of measurement has been explicitly taken into account to declare the compliance or non-compliance to the specification. The report must not be used by the client to claim product certification, approval, or endorsement by TAF or any government agencies.

## Table of Contents

Release Control Record .....	4
1 Certificate of Conformity .....	5
2 Summary of Test Results .....	6
2.1 Test Instruments.....	7
2.2 Measurement Uncertainty.....	8
2.3 Maximum Measurement Uncertainty.....	8
2.4 Modification Record.....	8
3 General Information.....	9
3.1 General Description of EUT.....	9
3.2 Description of Test Modes .....	11
3.2.1 Test Mode Applicability and Tested Channel Detail.....	12
3.3 Description of Support Units.....	15
3.3.1 Configuration of System under Test .....	15
3.4 General Description of Applied Standards.....	15
4 Test Procedure and Results .....	16
Transmitter Parameters .....	16
4.1 RF Output Power .....	16
4.1.1 Limits of RF Output Power.....	16
4.1.2 Test Procedures .....	16
4.1.3 Deviation from Test Standard.....	16
4.1.4 Test Setup .....	16
4.1.5 Test Results.....	17
4.2 Power Spectral Density .....	18
4.2.1 Limit of Power Spectral Density .....	18
4.2.2 Test Procedures .....	18
4.2.3 Deviation of Test Standard.....	18
4.2.4 Test Setup .....	18
4.2.5 Test Results.....	19
4.3 Adaptive (Channel Access Mechanism).....	20
4.3.1 Limit of Adaptive.....	20
4.3.2 Test Procedure .....	21
4.3.3 Deviation from Test Standard.....	21
4.3.4 Test Setup Configuration .....	21
4.3.5 List of Measurements .....	22
4.3.6 Interference Threshold Level .....	23
4.3.7 Test Result .....	27
4.3.7.1 Adaptive Result.....	27
4.3.7.2 The Channel Occupancy Time Result.....	32
4.3.7.3 Short Control Signalling Transmissions Result.....	36
4.4 Occupied Channel Bandwidth.....	40
4.4.1 Limit of Occupied Channel Bandwidth.....	40
4.4.2 Test Procedure .....	40
4.4.3 Deviation from Test Standard.....	40
4.4.4 Test Setup .....	40
4.4.5 Test Results.....	41
4.5 Transmitter Unwanted Emissions in the Out-of-band Domain.....	42
4.5.1 Limits of Transmitter Unwanted Emissions in the Out-of-band Domain.....	42
4.5.2 Test Procedure .....	42
4.5.3 Deviation from Test Standard.....	42
4.5.4 Test Setup .....	42
4.5.5 Test Results.....	43
4.6 Transmitter Spurious Emissions .....	45

4.6.1	Limits of Transmitter Spurious Emissions .....	45
4.6.2	Test Procedure .....	45
4.6.3	Deviation from Test Standard .....	45
4.6.4	Test Setup .....	45
4.6.5	Test Results .....	46
	Receiver Parameters .....	48
4.7	Receiver Spurious Radiation .....	48
4.7.1	Limit of Receiver Spurious Radiation .....	48
4.7.2	Test Procedure .....	48
4.7.3	Deviation from Test Standard .....	48
4.7.4	Test Setup .....	48
4.7.5	Test Results.....	49
4.8	Receiver Blocking .....	51
4.8.1	Limit of Receiver Blocking.....	51
4.8.2	Test Procedure .....	51
4.8.3	Deviation from Test Standard .....	51
4.8.4	Test Setup Configuration .....	52
4.8.5	Test Results.....	53
5	Photographs of the Test Configuration .....	54
	Appendix - Information on the Testing Laboratories .....	55

### Release Control Record

Issue No.	Description	Date Issued
RE161108D04	Original release.	Dec. 6, 2016

## 1 Certificate of Conformity

**Product:** Network Camera

**Brand:** VIVOTEK

**Test Model:** IP8160-W

**Sample Status:** Engineering sample

**Applicant:** VIVOTEK INC.

**Test Date:** Nov. 23 ~ 28, 2016

**Standards:** EN 300 328 V1.9.1 (2015-02)

The above equipment has been tested by **Bureau Veritas Consumer Products Services (H.K.) Ltd., Taoyuan Branch**, and found compliance with the requirement of the above standards. The test record, data evaluation & Equipment Under Test (EUT) configurations represented herein are true and accurate accounts of the measurements of the sample's EMC characteristics under the conditions specified in this report.

**Prepared by :** \_\_\_\_\_ , **Date:** \_\_\_\_\_  
Jessica Cheng / Senior Specialist

**Approved by :** \_\_\_\_\_ , **Date:** \_\_\_\_\_  
Rex Lai / Assistant Manager

## 2 Summary of Test Results

The EUT has been tested according to the following specifications:

EN 300 328 V1.9.1		
Clause	Test Parameter	Results
	<b>Transmitter Parameters</b>	
4.3.2.2	RF Output Power	Pass
4.3.2.3	Power Spectral Density (Modulations other than FHSS equipment)	Pass
4.3.2.4	Duty cycle, Tx-sequence, Tx-gap (Non-adaptive equipment)	Not Applicable
4.3.2.5	Medium Utilisation (Non-Adaptive Equipment)	Not Applicable
4.3.2.6	Adaptivity (Adaptive Equipment)	Pass
4.3.2.7	Occupied Channel Bandwidth	Pass
4.3.2.8	Transmitter Unwanted Emissions in the OOB Domain	Pass
4.3.2.9	Transmitter Unwanted Emissions in the Spurious Domain	Pass
4.3.2.12	Geo-location capability	Not Applicable
	<b>Receiver Parameters</b>	
4.3.2.10	Receiver Spurious Emissions	Pass
4.3.2.11	Receiver Blocking (Only for Adaptive equipment)	Pass

## 2.1 Test Instruments

DESCRIPTION & MANUFACTURER	MODEL NO.	SERIAL NO.	CALIBRATED DATE	CALIBRATED UNTIL
HP Preamplifier	8447D	2944A10505	Feb. 26, 2016	Feb. 25, 2017
HP Preamplifier	8449B	3008A01886	Feb. 26, 2016	Feb. 25, 2017
HP Preamplifier	8449B	3008A01887	Feb. 26, 2016	Feb. 25, 2017
ROHDE & SCHWARZ Spectrum Analyzer	FSP 40	100036	Jun. 07, 2016	Jun. 06, 2017
ROHDE & SCHWARZ Spectrum Analyzer	FSV 40	101042	Sep. 30, 2016	Sep. 29, 2017
Agilent Test Receiver	N9038A	MY51210129	Feb. 02, 2016	Feb. 01, 2017
ROHDE & SCHWARZ Signal Generator	SMR 40	100231	Jun. 22, 2016	Jun. 21, 2017
Tektronix Oscilloscope	TDS1012	C019167	Jan. 04, 2016	Jan. 03, 2017
Anritsu Peak Power meter	ML2495A	0842014	Apr. 28, 2016	Apr. 27, 2017
Anritsu Pulse Power Sensor	MA2411B	0738404	Apr. 28, 2016	Apr. 27, 2017
KEYSIGHT MXG Vector Signal Generator	N5182B	MY53052658	May 20, 2016	May 19, 2017
Schwarzbeck Antenna	VULB9168	139	Jan. 04, 2016	Jan. 03, 2017
EMCO Horn Antenna	3117	00034127	Jan. 20, 2016	Jan. 19, 2017
EMCO Horn Antenna	3115	00028257	Jan. 19, 2016	Jan. 18, 2017
Temperature & Humidity Chamber	MHU-225AU	920409	May 25, 2016	May 24, 2017
ADT. Controll	ADT100	0301	NA	NA
ADT. Turn Table	TT100	0301	NA	NA
ADT. Tower	AT100	0301	NA	NA
Software	Radiated_V7.6.15.9.5	NA	NA	NA
TIMES RF cable With 10dB PAD	LMR-600	CABLE-RF-01	Mar. 18, 2016	Mar. 17, 2017
SUHNER RF cable With 10dB PAD	SF 104	CABLE-RF-01	Aug. 15, 2016	Aug. 14, 2017
KEYSIGHT MIMO Powermeasurement Test set	U2021XA	U2021XA-001	May 25, 2016	May 24, 2017
KEYSIGHT Spectrum Analyzer	N9030A	MY54490260	Jul. 26, 2016	Jul. 25, 2017
Highpass filter Wainwright Instruments	WHK 3.1/18G-10SS	SN 8	NA	NA

- NOTE:**
1. The calibration interval of the above test instruments is 12 months. And the calibrations are traceable to NML/ROC and NIST/USA.
  2. The horn antenna and HP preamplifier (model: 8449B) are used only for the measurement of emission frequency above 1GHz if tested.
  3. The test was performed in Chia Pau RF Chamber

## 2.2 Measurement Uncertainty

Where relevant, the following measurement uncertainty levels have been estimated for tests performed on the EUT:

This uncertainty represents an expanded uncertainty expressed at approximately the 95% confidence level using a coverage factor of  $k=2$ .

Parameter	Uncertainty
Occupied Channel Bandwidth	$\pm 1.132 \times 10^{-4} \%$
RF output power, conducted	$\pm 1.371$ dB
Power Spectral Density, conducted	$\pm 1.371$ dB
All emissions, radiated	$\pm 3.294$ dB
Temperature	$\pm 0.23$ °C
Supply voltages	$\pm 0.3$ %
Time	$\pm 2.53$ %

## 2.3 Maximum Measurement Uncertainty

For the test methods, according to EN 300 328 standard, the measurement uncertainty figures shall be calculated in accordance with ETR 100 028-1 [4] and shall correspond to an expansion factor (coverage factor)  $k = 1,96$  or  $k = 2$  (which provide confidence levels of respectively 95 % and 95,45 % in the case where the distributions characterizing the actual measurement uncertainties are normal (Gaussian)).

Maximum measurement uncertainty

Parameter	Uncertainty
Occupied Channel Bandwidth	$\pm 5$ %
RF output power, conducted	$\pm 1,5$ dB
Power Spectral Density, conducted	$\pm 3$ dB
All emissions, radiated	$\pm 6$ dB
Temperature	$\pm 1$ °C
Supply voltages	$\pm 3$ %
Time	$\pm 5$ %

## 2.4 Modification Record

There were no modifications required for compliance.

### 3 General Information

#### 3.1 General Description of EUT

Product	Network Camera
Brand	VIVOTEK
Test Model	IP8160-W
Status of EUT	Engineering sample
Nominal Voltage	5Vdc from adapter
Normal Testing Voltage	5Vdc
Temperature Operating Range	0~40°C
Modulation Type	CCK, DQPSK, DBPSK for DSSS 64QAM, 16QAM, QPSK, BPSK for OFDM
Modulation Technology	DSSS, OFDM
Transfer Rate	802.11b: 11/5.5/2/1Mbps 802.11g: 54/48/36/24/18/12/9/6Mbps 802.11n: up to 300Mbps
Operating Frequency	2412MHz ~ 2472MHz
Number of Channel	802.11b, 802.11g, 802.11n (20MHz): 13 802.11n (40MHz): 9
EIRP Power (Measured Max. Average)	19.62dBm
Antenna Type	PCB antenna with 3.15dBi gain
Antenna Connector	IPEX
Accessory Device	Adapter
Data Cable Supplied	N/A

Note:

1. The EUT incorporates a MIMO function. Physically, the EUT provides 2 completed transmitters and 2 receivers.

Modulation Mode	TX Function
802.11b	1TX
802.11g	1TX
802.11n (20MHz)	2TX
802.11n (40MHz)	2TX

2. The EUT uses following adapter.

Adapter 1	
Brand	HONOTO
Model	ADS-12EA-05 05010E
Input Power	100-240V, 50/60Hz, 0.3A
Output Power	5V, 2.0A
Power Line	AC 2 Pin Shielded USB cable (1.2m)
Adapter 2	
Brand	Zzu
Model	ZZU1001-200050U
Input Power	100-240V, 50-60Hz, 0.5A
Output Power	5V, 2.0A
Power Line	AC 2 Pin Shielded USB cable (1.2m)

After pre-tested, the **Adapter 1** was the worse case and only its test data was recorded in this report.

3. The above EUT information is declared by manufacturer and for more detailed features description, please refer to the manufacturer's specifications or user's manual.

### 3.2 Description of Test Modes

13 channels are provided for 802.11b, 802.11g and 802.11n (20MHz):

CHANNEL	FREQUENCY	CHANNEL	FREQUENCY
1	2412 MHz	8	2447 MHz
2	2417 MHz	9	2452 MHz
3	2422 MHz	10	2457 MHz
4	2427 MHz	11	2462 MHz
5	2432 MHz	12	2467 MHz
6	2437 MHz	13	2472 MHz
7	2442 MHz		

9 channels are provided for 802.11n (40MHz):

CHANNEL	FREQUENCY	CHANNEL	FREQUENCY
3	2422MHz	8	2447MHz
4	2427MHz	9	2452MHz
5	2432MHz	10	2457MHz
6	2437MHz	11	2462MHz
7	2442MHz		



**Adaptivity Test:**

- Pre-Scan has been conducted to determine the worst-case mode from all possible combinations between available modulations, data rates and antenna ports (if EUT with antenna diversity architecture).
- Following channel(s) was (were) selected for the final test as listed below.

EUT CONFIGURE MODE	MODE	AVAILABLE CHANNEL	TESTED CHANNEL	MODULATION TECHNOLOGY	MODULATION TYPE	DATA RATE (Mbps)
-	802.11b	1 to 13	1, 13	DSSS	DBPSK	1.0
-	802.11g	1 to 13	1, 13	OFDM	BPSK	6.0
-	802.11n (20MHz)	1 to 13	1, 13	OFDM	BPSK	6.5
-	802.11n (40MHz)	3 to 11	3, 11	OFDM	BPSK	13.5

**Occupied Channel Bandwidth Test:**

- Pre-Scan has been conducted to determine the worst-case mode from all possible combinations between available modulations, data rates and antenna ports (if EUT with antenna diversity architecture).
- Following channel(s) was (were) selected for the final test as listed below.

EUT CONFIGURE MODE	MODE	AVAILABLE CHANNEL	TESTED CHANNEL	MODULATION TECHNOLOGY	MODULATION TYPE	DATA RATE (Mbps)
-	802.11b	1 to 13	1, 13	DSSS	DBPSK	1.0
-	802.11g	1 to 13	1, 13	OFDM	BPSK	6.0
-	802.11n (20MHz)	1 to 13	1, 13	OFDM	BPSK	6.5
-	802.11n (40MHz)	3 to 11	3, 11	OFDM	BPSK	13.5

**Transmitter Unwanted Emissions in the Out-of-band Domain Test:**

- Pre-Scan has been conducted to determine the worst-case mode from all possible combinations between available modulations, data rates and antenna ports (if EUT with antenna diversity architecture).
- Following channel(s) was (were) selected for the final test as listed below.

EUT CONFIGURE MODE	MODE	AVAILABLE CHANNEL	TESTED CHANNEL	MODULATION TECHNOLOGY	MODULATION TYPE	DATA RATE (Mbps)
-	802.11b	1 to 13	1, 13	DSSS	DBPSK	1.0
-	802.11g	1 to 13	1, 13	OFDM	BPSK	6.0
-	802.11n (20MHz)	1 to 13	1, 13	OFDM	BPSK	6.5
-	802.11n (40MHz)	3 to 11	3, 11	OFDM	BPSK	13.5

**Unwanted Emissions in the Spurious Domain Test (Below 1 GHz):**

- Pre-Scan has been conducted to determine the worst-case mode from all possible combinations between available modulations, data rates and antenna ports (if EUT with antenna diversity architecture).
- Following channel(s) was (were) selected for the final test as listed below.

EUT CONFIGURE MODE	MODE	AVAILABLE CHANNEL	TESTED CHANNEL	MODULATION TECHNOLOGY	MODULATION TYPE	DATA RATE (Mbps)
-	802.11b	1 to 13	1	DSSS	DBPSK	1.0
-	Receiver	1 to 13	1	-	-	-

**Unwanted Emissions in the Spurious Domain Test (above 1 GHz):**

- Pre-Scan has been conducted to determine the worst-case mode from all possible combinations between available modulations, data rates and antenna ports (if EUT with antenna diversity architecture).
- Following channel(s) was (were) selected for the final test as listed below.

EUT CONFIGURE MODE	MODE	AVAILABLE CHANNEL	TESTED CHANNEL	MODULATION TECHNOLOGY	MODULATION TYPE	DATA RATE (Mbps)
-	802.11b	1 to 13	1, 13	DSSS	DBPSK	1.0
-	Receiver	1 to 13	1, 13	-	-	-

**Receiver Blocking test:**

- Pre-Scan has been conducted to determine the worst-case mode from all possible combinations between available modulations, data rates and antenna ports (if EUT with antenna diversity architecture).
- Following channel(s) was (were) selected for the final test as listed below.

EUT CONFIGURE MODE	MODE	AVAILABLE CHANNEL	TESTED CHANNEL	MODULATION TECHNOLOGY	MODULATION TYPE	DATA RATE (Mbps)
-	802.11b	1 to 13	1, 13	DSSS	DBPSK	1.0
-	802.11g	1 to 13	1, 13	OFDM	BPSK	6.0
-	802.11n (20MHz)	1 to 13	1, 13	OFDM	BPSK	6.5
-	802.11n (40MHz)	3 to 11	3, 11	OFDM	BPSK	13.5

**Test Condition:**

Applicable to	Environmental Conditions	Input Power	Tested by
ROP	25deg. C, 76%RH	5Vdc	Saxon Lee
PSD	25deg. C, 76%RH	5Vdc	Saxon Lee
AD	25deg. C, 76%RH	5Vdc	Saxon Lee
OCB	25deg. C, 76%RH	5Vdc	Saxon Lee
EOB	25deg. C, 76%RH	5Vdc	Saxon Lee
SE<1G	27deg. C, 67%RH	5Vdc	Dalen Dai
SE <sup>3</sup> 1G	27deg. C, 67%RH	5Vdc	Dalen Dai
RB	25deg. C, 76%RH	5Vdc	Saxon Lee

### 3.3 Description of Support Units

The EUT has been tested as an independent unit together with other necessary accessories or support units. The following support units or accessories were used to form a representative test configuration during the tests.

ID	Descriptions	Qty.	Length (m)	Shielding (Yes/No)	Cores (Qty.)	Remarks
1.	USB cable	1	1.2	Y	0	Supplied by client

Note: The core(s) is(are) originally attached to the cable(s).

#### 3.3.1 Configuration of System under Test

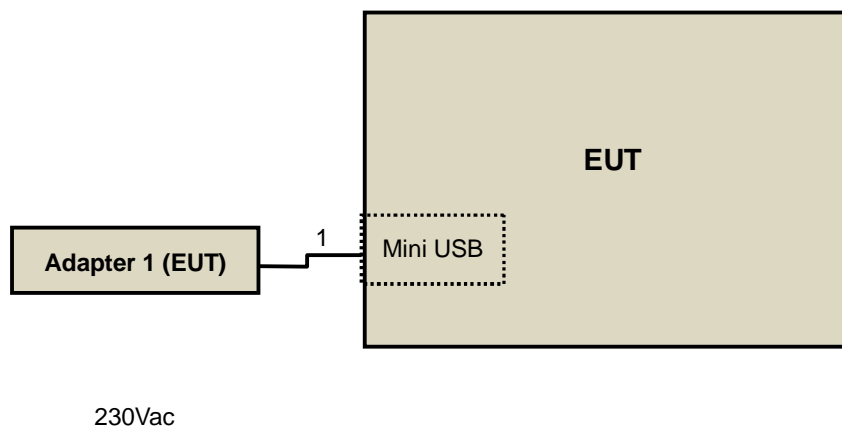

### 3.4 General Description of Applied Standards

The EUT is a RF Product. According to the specifications of the manufacturer, it must comply with the requirements of the following standard:

**EN 300 328 V1.9.1 (2015-02)**

All test items have been performed and recorded as per the above standard.

## 4 Test Procedure and Results

### Transmitter Parameters

#### 4.1 RF Output Power

##### 4.1.1 Limits of RF Output Power

Condition	Frequency Band	Limit (e.i.r.p)
Under all test conditions	2400 ~ 2483.5 MHz	AV: 20dBm

##### 4.1.2 Test Procedures

Refer to chapter 5.3.2.2 of EN 300 328 V1.9.1.

Measurement Method	
<input checked="" type="checkbox"/> Conducted measurement	<input type="checkbox"/> Radiated measurement

##### 4.1.3 Deviation from Test Standard

No deviation.

##### 4.1.4 Test Setup

The measurement was performed at both normal environmental conditions and at the extremes of the operating temperature. The measurement was performed at the lowest, the middle, and the highest channel. The equipment was configured to operate under its worst case situation with respect to output power. In case of conducted measurements the transmitter shall be connected to the measuring equipment via a suitable attenuator. Controlling software has been activated to set the EUT on specific channel and power level.

#### 4.1.5 Test Results

Test Condition			EIRP Power (dBm)		
			(CH1) 2412 MHz	(CH7) 2442 MHz	(CH13) 2472 MHz
<b>802.11b</b>					
T <sub>nom</sub> (°C)	+25	V <sub>nom</sub> (v)	18.07	17.98	17.94
T <sub>min</sub> (°C)	0	V <sub>nom</sub> (v)	19.57	19.46	19.43
T <sub>max</sub> (°C)	+40	V <sub>nom</sub> (v)	17.26	17.18	17.15
<b>802.11g</b>					
T <sub>nom</sub> (°C)	+25	V <sub>nom</sub> (v)	18.09	18.00	18.02
T <sub>min</sub> (°C)	0	V <sub>nom</sub> (v)	19.48	19.40	19.43
T <sub>max</sub> (°C)	+40	V <sub>nom</sub> (v)	16.87	16.83	16.84
<b>802.11n (20MHz)</b>					
T <sub>nom</sub> (°C)	+25	V <sub>nom</sub> (v)	17.97	17.93	17.90
T <sub>min</sub> (°C)	0	V <sub>nom</sub> (v)	19.56	19.53	19.50
T <sub>max</sub> (°C)	+40	V <sub>nom</sub> (v)	16.97	16.93	16.88
TEST CONDITION			EIRP POWER (dBm)		
			(CH3) 2422 MHz	(CH7) 2442 MHz	(CH11) 2462 MHz
<b>802.11n (40MHz)</b>					
T <sub>nom</sub> (°C)	+25	V <sub>nom</sub> (v)	17.94	17.90	17.86
T <sub>min</sub> (°C)	0	V <sub>nom</sub> (v)	<b>19.62</b>	19.59	19.57
T <sub>max</sub> (°C)	+40	V <sub>nom</sub> (v)	16.82	16.79	16.76

## 4.2 Power Spectral Density

### 4.2.1 Limit of Power Spectral Density

Condition	Frequency Band	Limit (e.i.r.p.)
Under normal conditions	2400 ~ 2483.5 MHz	10dBm / 1MHz

### 4.2.2 Test Procedures

Refer to chapter 5.3.3.2 of EN 300 328 V1.9.1.

Measurement Method	
<input checked="" type="checkbox"/> Conducted measurement	<input type="checkbox"/> Radiated measurement

### 4.2.3 Deviation of Test Standard

No deviation.

### 4.2.4 Test Setup

The measurement was performed at normal environmental conditions only. The measurement was performed at the lowest, the middle, and the highest channel. The equipment was configured to operate under its worst case situation with respect to output power. In case of conducted measurements the transmitter shall be connected to the measuring equipment via a suitable attenuator. The power spectral density as defined in EN 300 328 clause 4.3.2.3 shall be measured and recorded. Controlling software has been activated to set the EUT on specific status.

#### 4.2.5 Test Results

##### 802.11b

Channel	Channel Frequency (MHz)	Power Density (dBm/1MHz) (EIRP)	Limit (dBm/1MHz) (EIRP)	Pass/Fail
1	2412	9.42	10	Pass
7	2442	9.32	10	Pass
13	2472	9.31	10	Pass

##### 802.11g

Channel	Channel Frequency (MHz)	Power Density (dBm/1MHz) (EIRP)	Limit (dBm/1MHz) (EIRP)	Pass/Fail
1	2412	6.35	10	Pass
7	2442	6.23	10	Pass
13	2472	6.28	10	Pass

##### 802.11n (20MHz)

CHANNEL	CHANNEL FREQUENCY (MHz)	POWER DENSITY (dBm/1MHz) (E.I.R.P)	LIMIT (dBm/1MHz) (E.I.R.P)	PASS/FAIL
1	2412	6.03	10	Pass
7	2442	5.98	10	Pass
13	2472	5.96	10	Pass

##### 802.11n (40MHz)

CHANNEL	CHANNEL FREQUENCY (MHz)	POWER DENSITY (dBm/1MHz) (E.I.R.P)	LIMIT (dBm/1MHz) (E.I.R.P)	PASS/FAIL
3	2422	3.35	10	Pass
7	2442	3.27	10	Pass
11	2462	3.23	10	Pass

### 4.3 Adaptive (Channel Access Mechanism)

This requirement does not apply to non-adaptive equipment or adaptive equipment operating in a non-adaptive mode providing the equipment complies with the requirements and/or restrictions applicable to non-adaptive equipment.

In addition, this requirement does not apply for equipment with a maximum declared RF Output power level of less than 10 dBm e.i.r.p. or for equipment when operating in a mode where the RF Output power is less than 10 dBm e.i.r.p.

#### 4.3.1 Limit of Adaptive

#### Applicability of adaptive requirements and limit for wide band modulation techniques Interference threshold level

Requirement	Operational Mode			
	Non-LBT based Detect and Avoid	Frame Based Equipment	Load Based Equipment (Base on 'Spectrum Sharing' mechanisms)	Load Based Equipment (Not using any of the mechanisms referenced)
Minimum Clear Channel Assessment (CCA) Time	NA	18 us (see note 1)	(see note 2)	18 us (see note 1)
Maximum Channel Occupancy (COT) Time	40 ms	1 ms to 10 ms	(see note 2)	13ms
Minimum Idle Period	5us	5% of COT	(see note 2)	18us (see note 3)
Extended CCA check	NA	NA	(see note 2)	18us~160us
Short Control Signalling Transmissions	Maximum duty cycle of 10 % within an observation period of 50 ms (see note 4)			
NOTE 1: The CCA time used by the equipment shall be declared by the supplier.				
NOTE 2: Load Based Equipment may implement an LBT based spectrum sharing mechanism based on the Clear Channel Assessment (CCA) mode using energy detect, as described in IEEE 802.11™-2012 clause 9, clause 10, clause 16, clause 17, clause 19 and clause 20, or in IEEE 802.15.4™-2011 [i.4], clause 4, clause 5 and clause 8				
NOTE 3: The Idle Period in between transmissions is considered to be the CCA or the Extended CCA check as there are no transmissions during this period.				
NOTE 4: Adaptive equipment may or may not have Short Control Signalling Transmissions				

Maximum transmit power ( $P_H$ ) EIRP dBm	Threshold level (TL) (see notes 1 and 2)
20	-70 dBm / MHz
NOTE 1: $TL = -70 \text{ dBm/MHz} + [20 - P_H \text{ (assuming a 0dBi receive antenna and } P_H \text{ specified in dBm e.i.r.p.)}] / 1\text{MHz}$ .	
NOTE 2: transmitter the CCA threshold level (TL) shall be equal or lower than -70 dBm/MHz at the input to the receiver (assuming a 0 dBi receive antenna).	

### 4.3.2 Test Procedure

Refer to chapter 5.3.7.2 of EN 300 328 V1.9.1.

Measurement Method	
<input checked="" type="checkbox"/> Conducted measurement	<input type="checkbox"/> Radiated measurement

### 4.3.3 Deviation from Test Standard

No deviation.

### 4.3.4 Test Setup Configuration

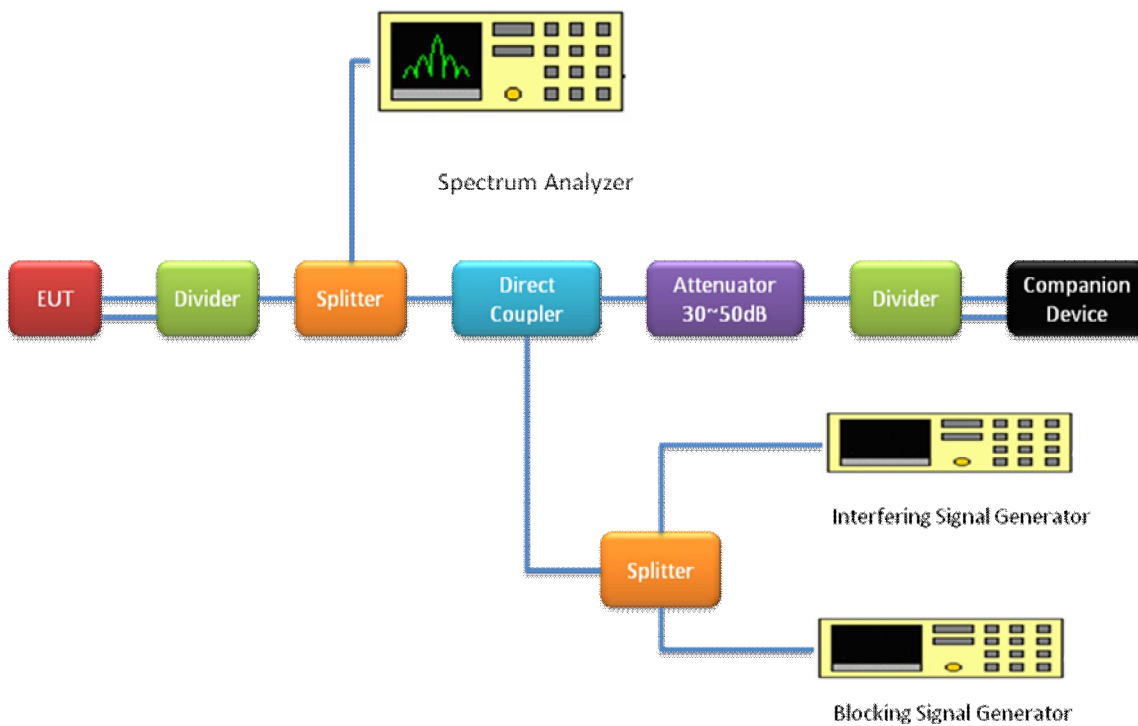

#### 4.3.5 List of Measurements

UUT Operational Mode	Applicable	Limit	
		The Maximum Channel Occupancy Time	The Minimum idle Period
Frame Based Equipment		meet in 1ms ~ 10ms	>5% x channel occupancy time
Load Based Equipment (Base on 'Spectrum Sharing' mechanisms)		Follow IEEE 802.11 Less than ____ms	Follow IEEE 802.11 More than ____ms
Load Based Equipment (Not using any of the mechanisms referenced)	v	13ms	18us

Clause	Test Parameter	Remarks	Pass/Fail
4.3.2.6.3.2.2	Adaptive (Frame Based Equipment)	Not Applicable	NA
4.3.2.6.3.2.3	Adaptive (Load Based Equipment)	Applicable	Pass
4.3.2.6.4	Short Control Signalling Transmissions	Applicable	Pass

### 4.3.6 Interference Threshold Level

#### 802.11b

#### Detection Threshold Level

The maximum EIRP (Vnom) power is 18.07dBm and antenna gain is 3.15dBi.  
 Detection Threshold level=  $-70\text{dBm/MHz} + 20 - \text{Pout EIRP}(18.07\text{dBm}) + G (3.15\text{dBi}) = -64.92\text{dBm/MHz}$  .  
 The interference signal level to the UUT is  $-64.92\text{dBm/MHz}$



Ref -10 dBm      \*Att 0 dB      RBW 1 MHz      Marker 1 [T1 ]  
 \*VBW 3 MHz      -64.92 dBm  
 \*SWT 1 s      2.418950000 GHz

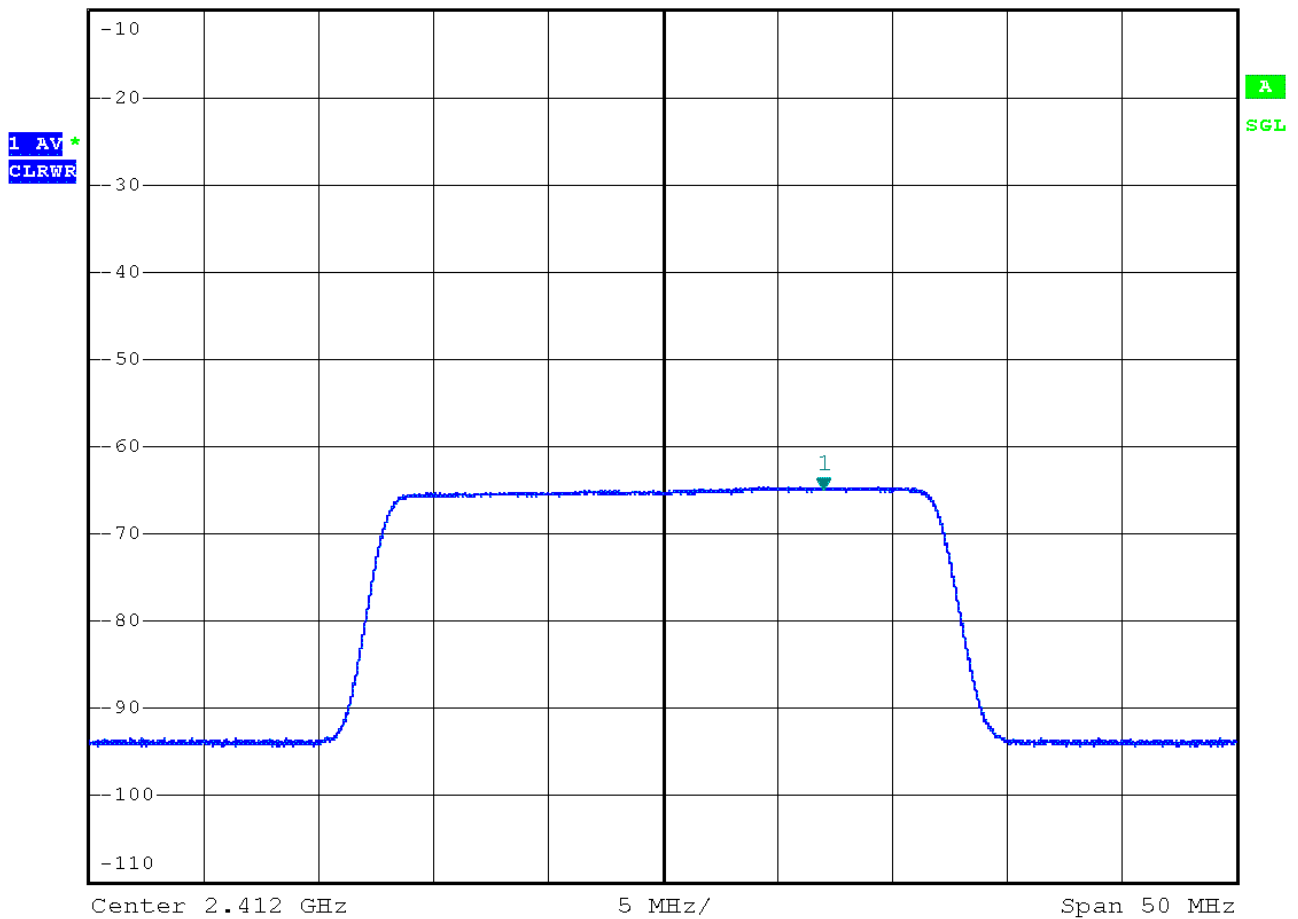

802.11g

Detection Threshold Level

The maximum EIRP (Vnom) power is 18.09dBm and antenna gain is 3.15dBi.  
 Detection Threshold level=  $-70\text{dBm/MHz} + 20 - \text{Pout EIRP}(18.09\text{dBm}) + G (3.15\text{dBi}) = -64.94\text{dBm/MHz}$  .  
 The interference signal level to the UUT is  $-64.94\text{dBm/MHz}$



RBW 1 MHz      Marker 1 [T1 ]  
 \*VBW 3 MHz      -64.94 dBm  
 \*SWT 1 s      2.418050000 GHz  
 Ref -10 dBm      \*Att 0 dB

1 AV \*  
 CLRWR

A  
 SGL

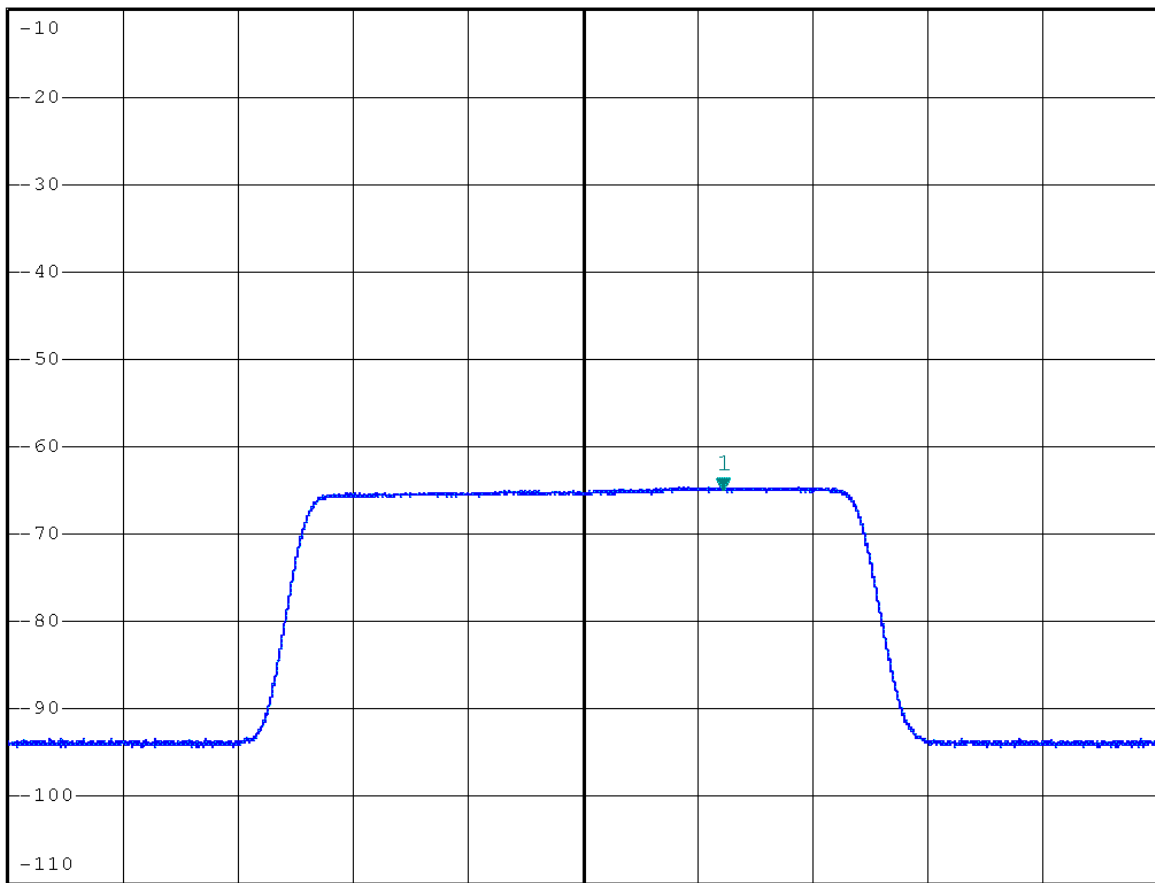

Center 2.412 GHz      5 MHz/      Span 50 MHz





#### 4.3.7 Test Result

- |  |
|--|
| <input type="checkbox"/> Not applicable to non-adaptive equipment or adaptive equipment operating in a non-adaptive mode |
| <input type="checkbox"/> Not applicable to equipment with RF output power is less than 10 dBm e.i.r.p.                   |
| <input checked="" type="checkbox"/> Refer to below test result   |

#### 4.3.7.1 Adaptive Result

##### Operating Frequency Bands and Mode of EUT

Operational Mode	Operating Frequency (Low Channel, MHz)	Operating Frequency (High Channel, MHz)	Test Result
802.11b	2412	2472	Pass
802.11g	2412	2472	Pass
802.11n (20MHz)	2412	2472	Pass
802.11n (40MHz)	2422	2462	Pass



802.11g CH01 2412 MHz



RBW 10 MHz    Marker 2 [T1 ]  
 \*VBW 10 MHz                                -74.61 dBm  
 Ref -10 dBm                                \*Att 0 dB                                SWT 70 s                                5.000000 s

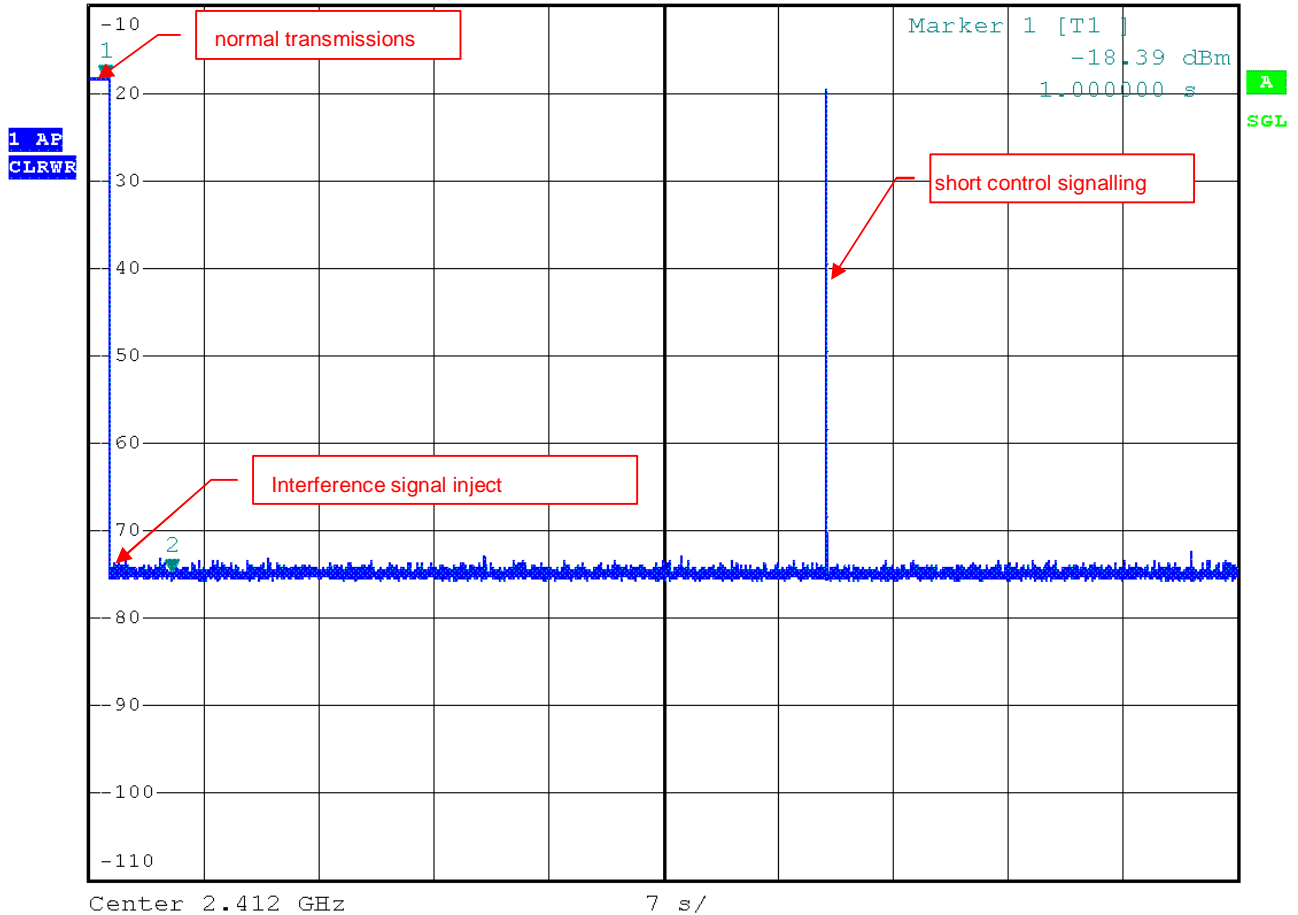

(The test plot was presents representative mode (11g Ch01) in report)



802.11n (40MHz) CH03 2422 MHz



RBW 10 MHz    Marker 2 [T1 ]  
 \*VBW 10 MHz                                -74.15 dBm  
 Ref -10 dBm                                \*Att 0 dB                                SWT 70 s                                5.000000 s

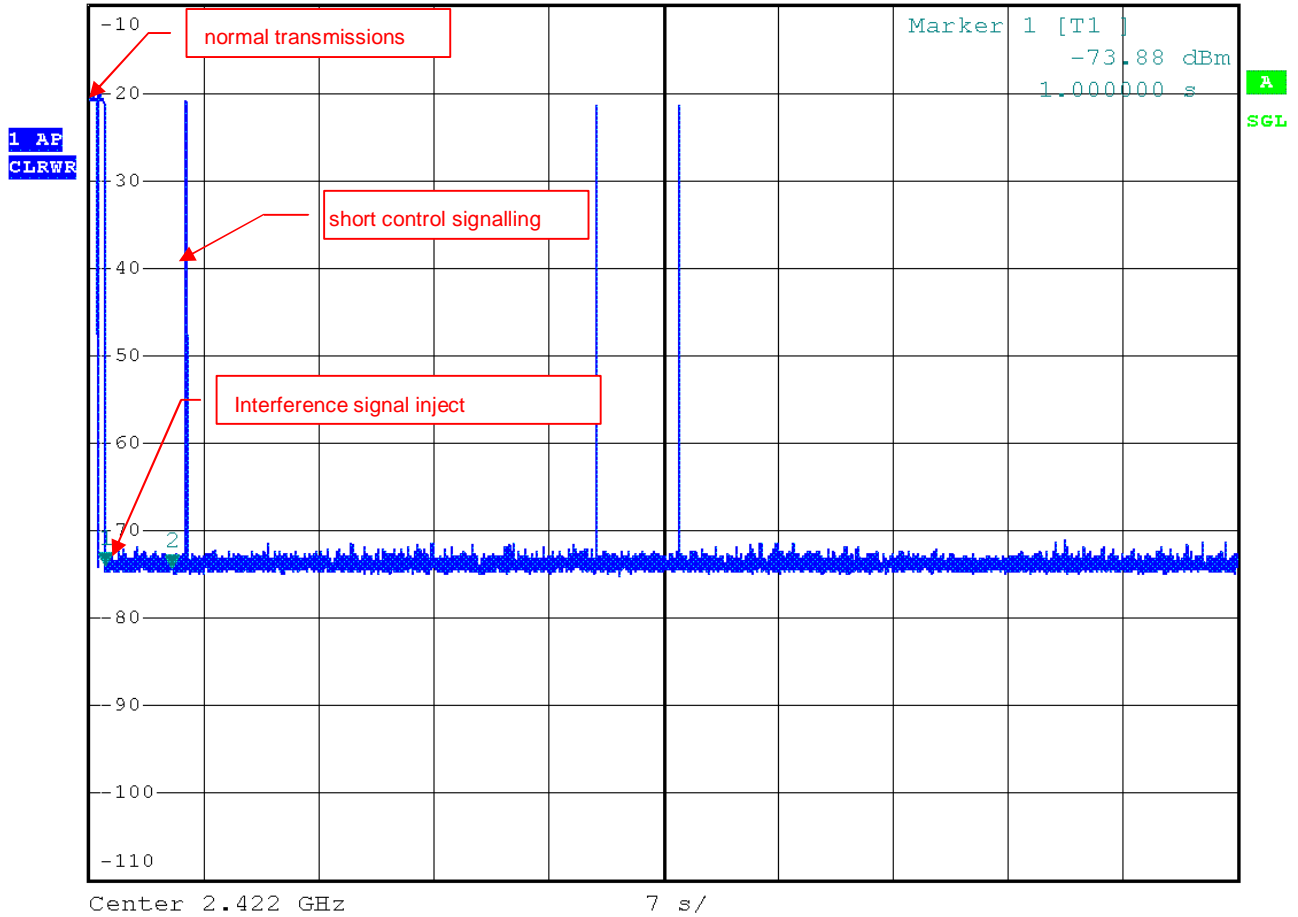

(The test plot was presents representative mode (11n (40MHz) Ch03) in report)

### 4.3.7.2 The Channel Occupancy Time Result

#### Operating Frequency Bands and Mode of EUT

Operational Mode	Operating Frequency Low Channel (MHz)	The Channel Occupancy Time (ms)	Minimum Idle Period (ms)	Test Result
802.11b	2412	1.299	0.23	Pass
802.11g	2412	0.249	0.056	Pass
802.11n (20MHz)	2412	0.881	0.1	Pass
802.11n (40MHz)	2422	1.945	0.12	Pass

#### 802.11b mode

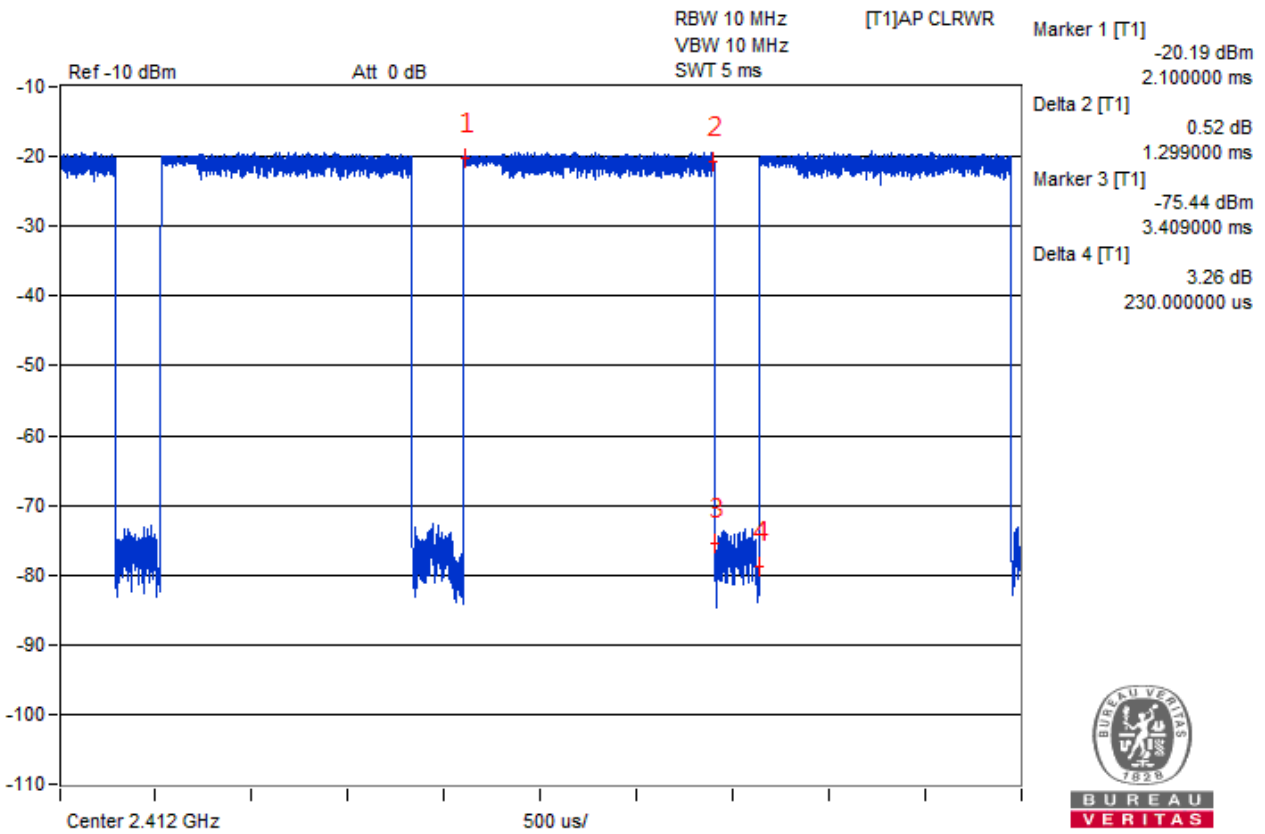



### 802.11g mode

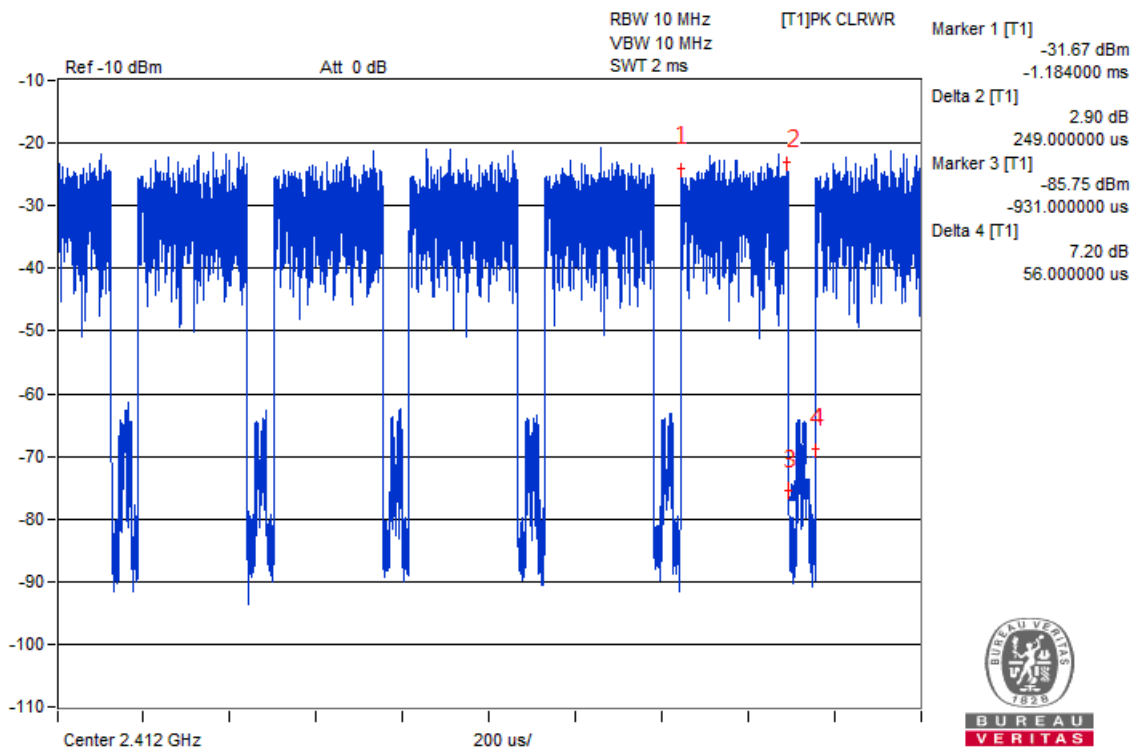



BUREAU  
VERITAS

### 802.11n (20MHz) mode

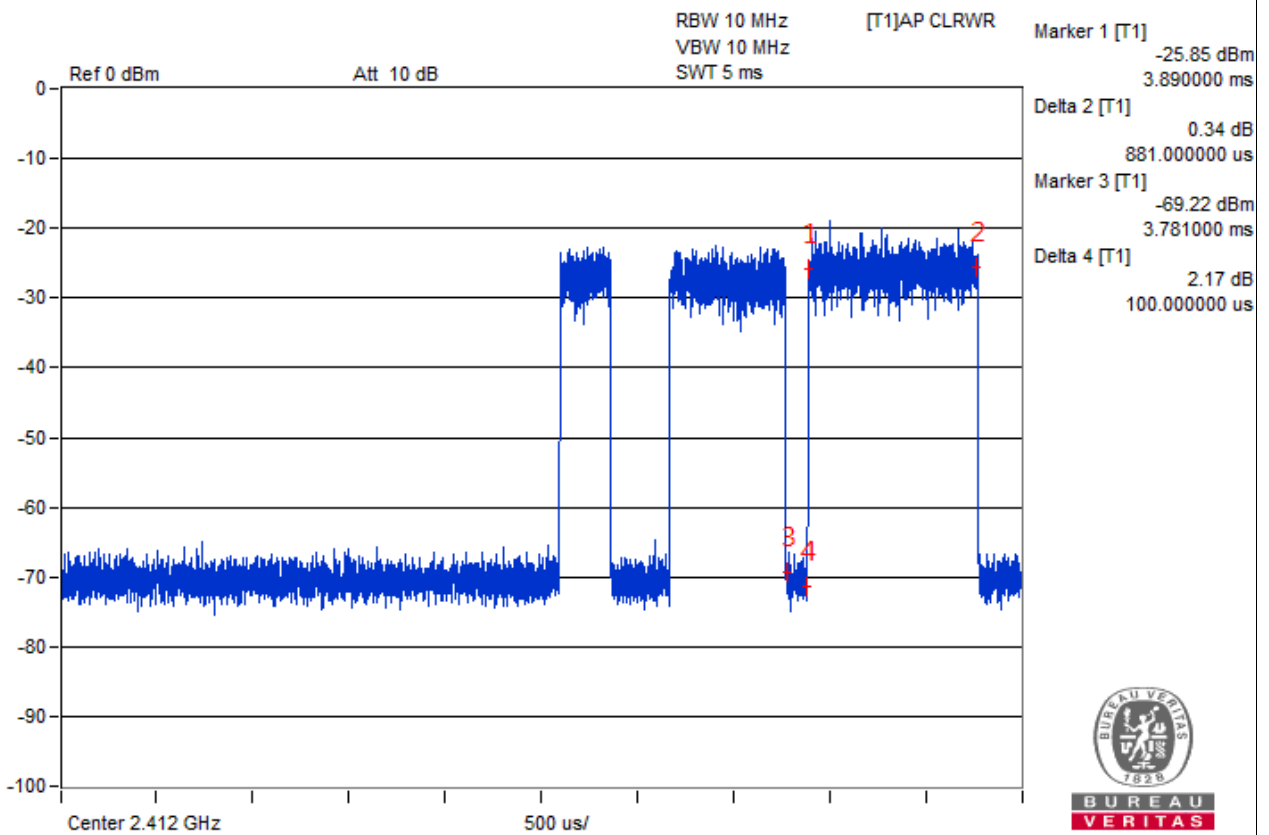

**802.11n (40MHz) mode**

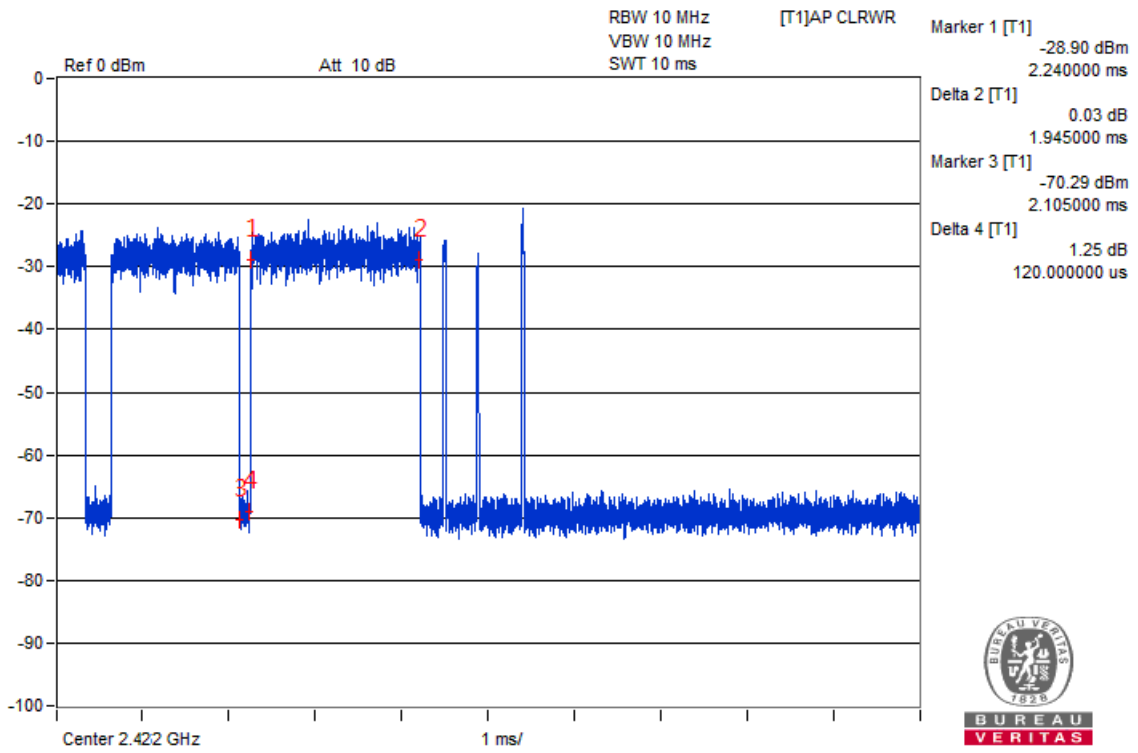

### 4.3.7.3 Short Control Signalling Transmissions Result

802.11b

#### Short Control Signalling Transmission Result

The SCST limit is 5ms

The SCST total on time is 0.364375 ms < SCST limit



Ref -10 dBm      \*Att 0 dB      RBW 10 MHz      Delta 2 [T1 ]  
 \*VBW 10 MHz      -1.59 dB  
 SWT 50 ms      364.375000 µs

1 AF  
VIEW

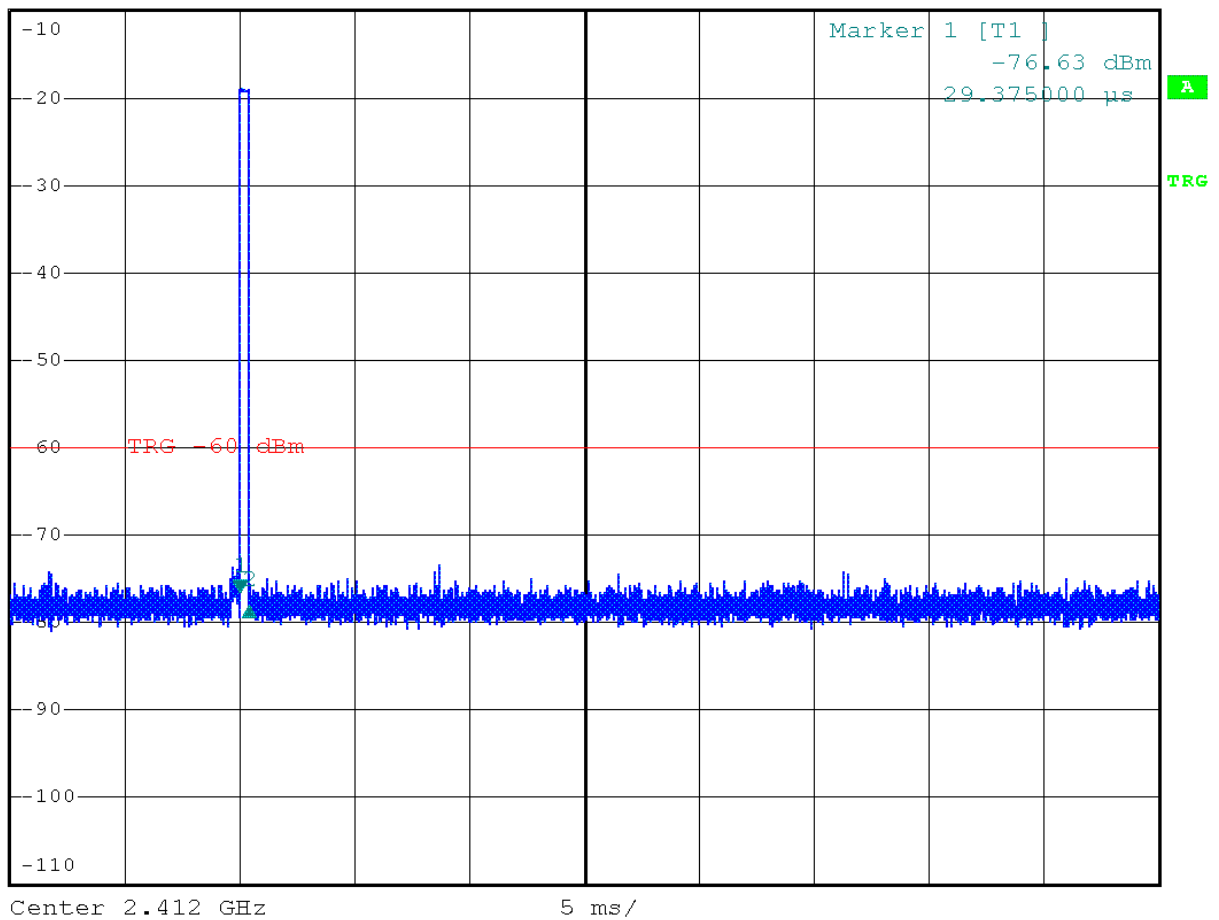

The short control signalling transmission length

802.11g

**Short Control Signalling Transmission Result**

The SCST limit is 5ms

The SCST total on time is 0.9ms < SCST limit



Ref -10 dBm      \*Att 0 dB      RBW 10 MHz      Delta 2 [T1 ]  
 \*VBW 10 MHz      0.67 dB  
 SWT 50 ms      900.000000 µs

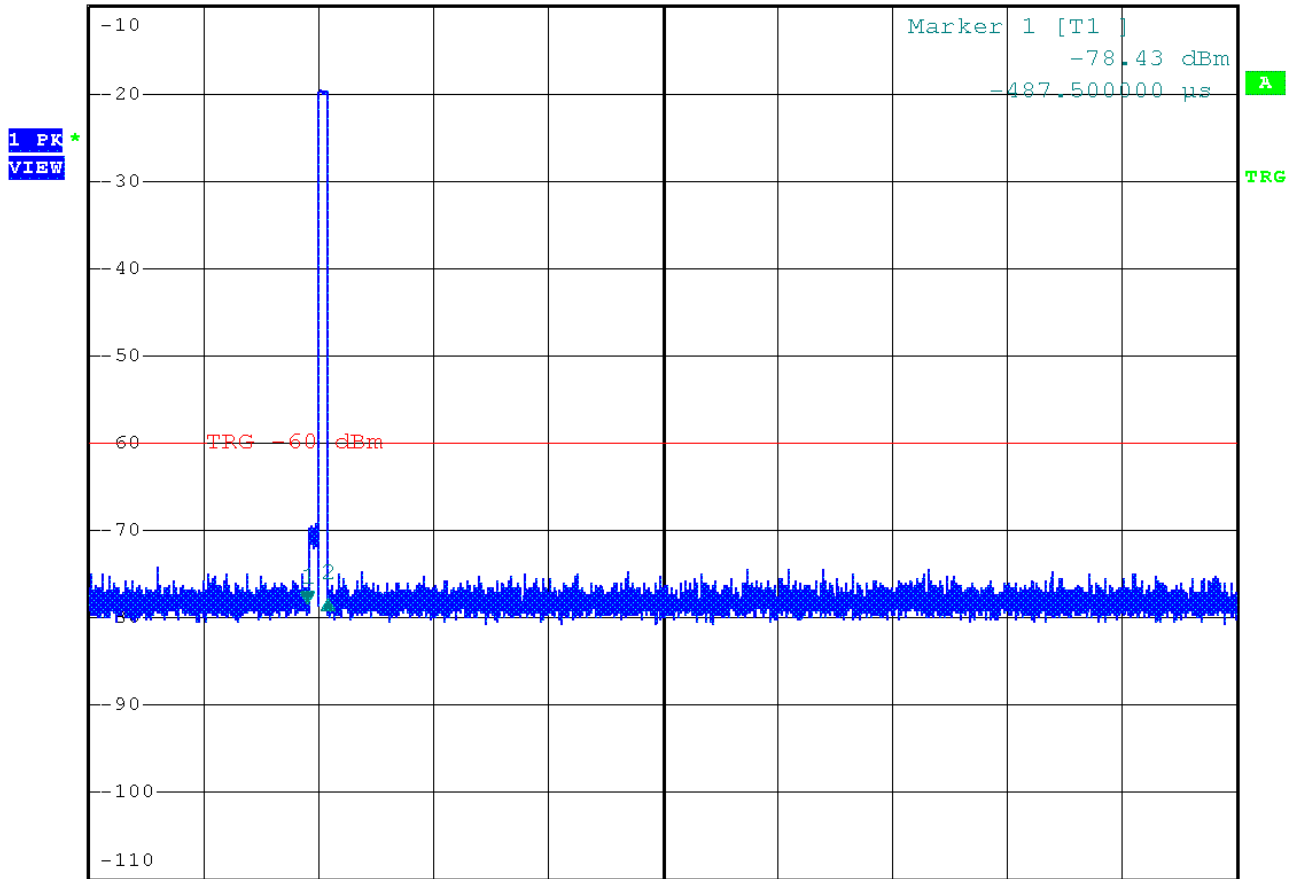

Center 2.412 GHz

5 ms/

The short control signalling transmission length

802.11n (20MHz)

**Short Control Signalling Transmission Result**

The SCST limit is 5ms

The SCST total on time is 0.2875ms < SCST limit



Ref -10 dBm      \*Att 0 dB      RBW 10 MHz      Delta 2 [T1 ]  
 \*VBW 10 MHz      -0.34 dB  
 SWT 50 ms      287.500000 µs

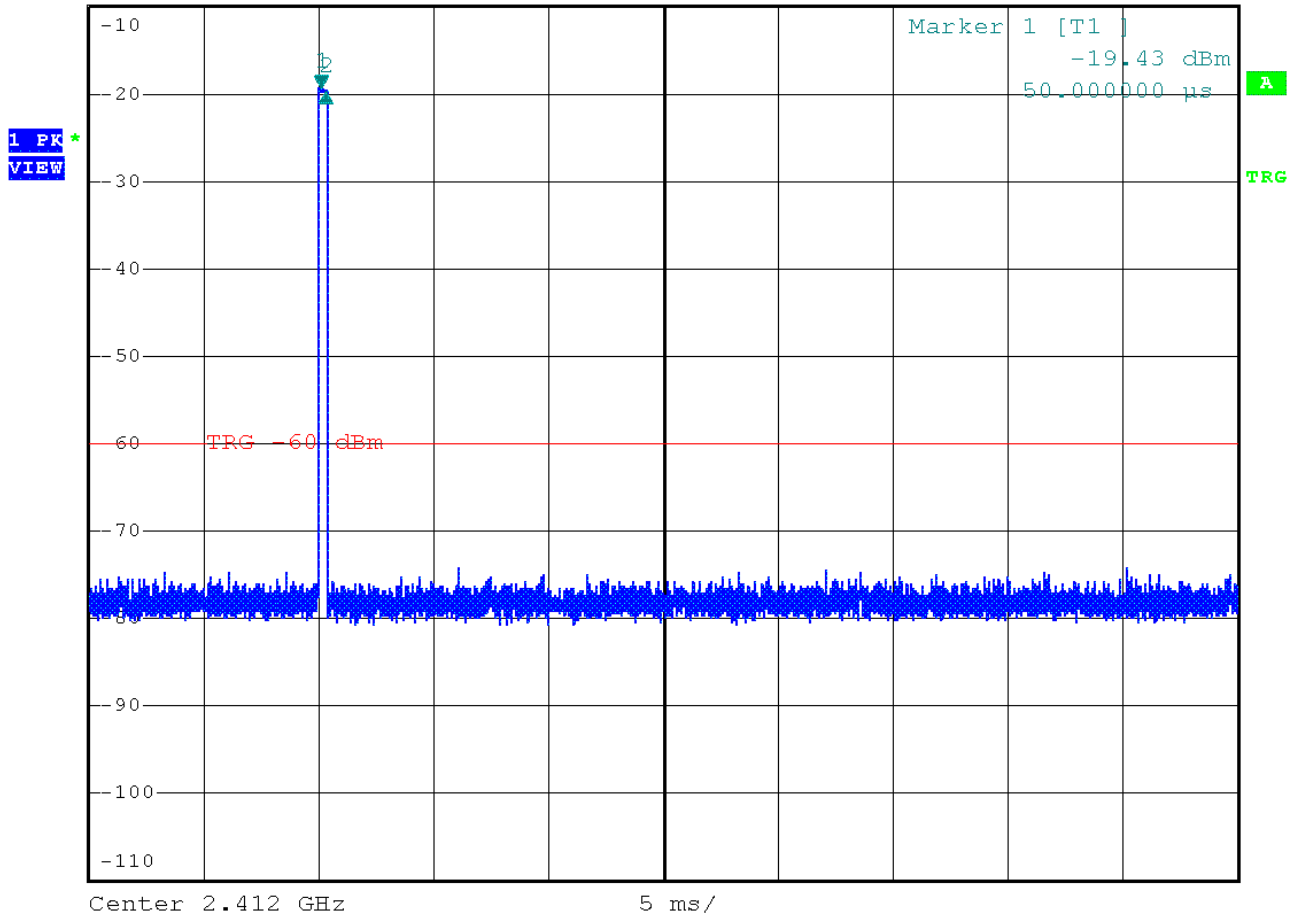

The short control signalling transmission length

802.11n (40MHz)

Short Control Signalling Transmission Result

The SCST limit is 5ms

The SCST total on time is 0.2125ms < SCST limit



Ref -10 dBm      \*Att 0 dB      RBW 10 MHz      Delta 2 [T1 ]  
 \*VBW 10 MHz      -0.15 dB  
 SWT 50 ms      212.500000 µs

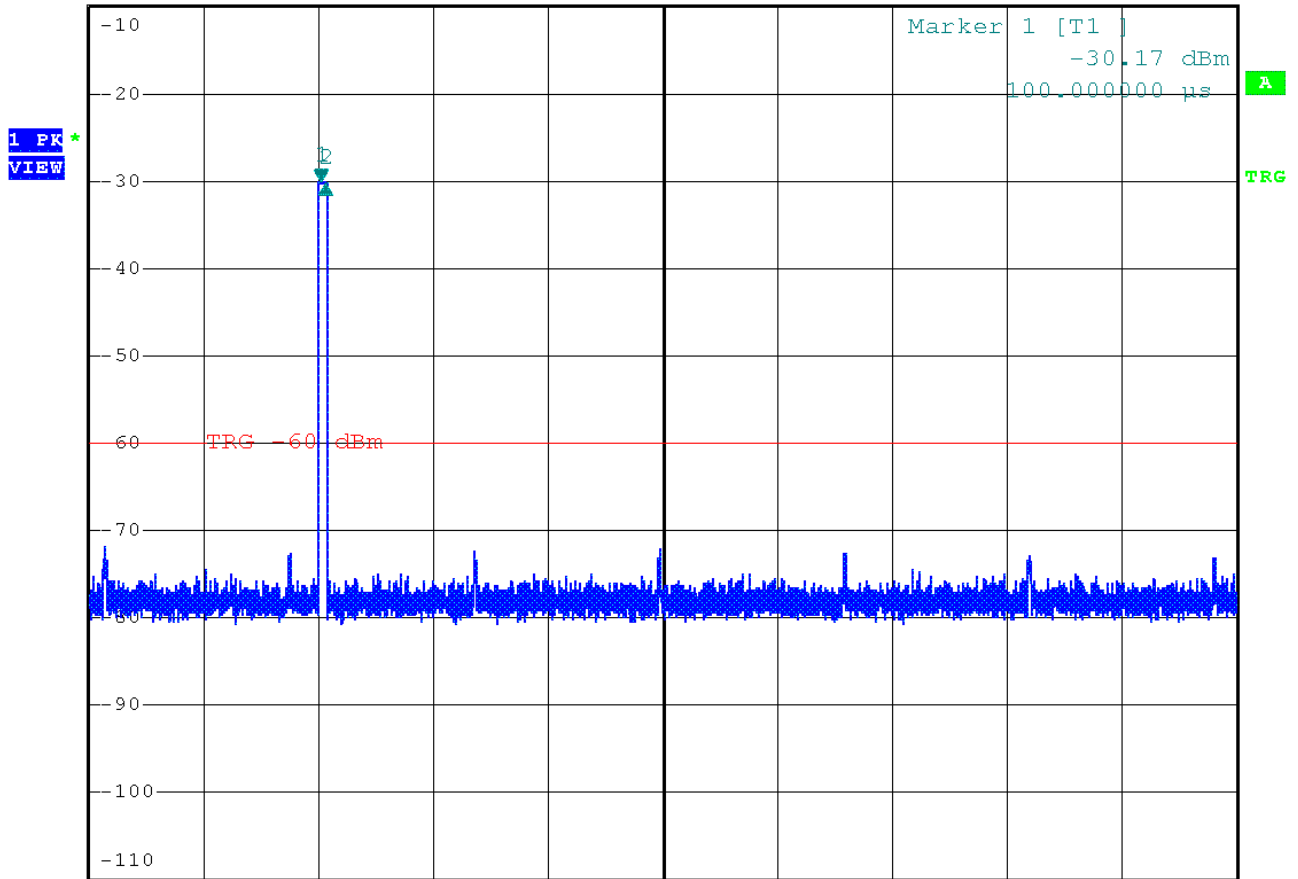

The short control signalling transmission length

#### 4.4 Occupied Channel Bandwidth

##### 4.4.1 Limit of Occupied Channel Bandwidth

Condition		Limit
All types of equipment		Shall fall completely within the band 2400 to 2483.5 MHz.
Additional requirement	For non-adaptive using wide band modulations other than FHSS system and e.i.r.p >10dBm.	Less than 20MHz
	For non-adaptive Frequency Hopping system and e.i.r.p >10dBm.	Less than 5MHz

##### 4.4.2 Test Procedure

Refer to chapter 5.3.8.2 of EN 300 328 V1.9.1.

Measurement	
<input checked="" type="checkbox"/> Conducted measurement	<input type="checkbox"/> Radiated measurement

##### 4.4.3 Deviation from Test Standard

No deviation.

##### 4.4.4 Test Setup

The measurement was performed at normal environmental conditions only. This measurement was performed at the lowest and the highest channel. The equipment was configured to operate under its worst case situation with respect to output power. In case of conducted measurements the transmitter shall be connected to the measuring equipment via a suitable attenuator. Controlling software has been activated to set the EUT on specific status.

#### 4.4.5 Test Results

##### 802.11b

Channel	Channel Frequency (MHz)	Occupied Bandwidth (MHz)	Measured Frequencies		Limit	Pass/Fail
			F <sub>L</sub> (MHz)	F <sub>H</sub> (MHz)		
1	2412	14.95	2404.58	2419.53	F <sub>L</sub> > 2400 MHz and F <sub>H</sub> < 2483.5 MHz	Pass
13	2472	14.96	2464.56	2479.52		Pass

##### 802.11g

Channel	Channel Frequency (MHz)	Occupied Bandwidth (MHz)	Measured Frequencies		Limit	Pass/Fail
			F <sub>L</sub> (MHz)	F <sub>H</sub> (MHz)		
1	2412	16.48	2403.76	2420.24	F <sub>L</sub> > 2400 MHz and F <sub>H</sub> < 2483.5 MHz	Pass
13	2472	16.48	2463.76	2480.24		Pass

##### 802.11n (20MHz)

Channel	Channel Frequency (MHz)	Occupied Bandwidth (MHz)	Measured Frequencies		Limit	Pass/Fail
			F <sub>L</sub> (MHz)	F <sub>H</sub> (MHz)		
1	2412	17.63	2403.18	2420.81	F <sub>L</sub> > 2400 MHz and F <sub>H</sub> < 2483.5 MHz	Pass
13	2472	17.68	2463.12	2480.8		Pass

##### 802.11n (40MHz)

Channel	Channel Frequency (MHz)	Occupied Bandwidth (MHz)	Measured Frequencies		Limit	Pass/Fail
			F <sub>L</sub> (MHz)	F <sub>H</sub> (MHz)		
3	2422	36.32	2403.92	2440.24	F <sub>L</sub> > 2400 MHz and F <sub>H</sub> < 2483.5 MHz	Pass
11	2462	36.48	2443.76	2480.24		Pass

Note: F<sub>L</sub> is the lowest frequency of the 99% occupied bandwidth of power envelope.  
 F<sub>H</sub> is the highest frequency of the 99% occupied bandwidth of power envelope.

## 4.5 Transmitter Unwanted Emissions in the Out-of-band Domain

### 4.5.1 Limits of Transmitter Unwanted Emissions in the Out-of-band Domain

Condition	Limit
Under all test conditions	The transmitter unwanted emissions in the out-of-band domain but outside the allocated band, shall not exceed the values provided by the mask in below figure.

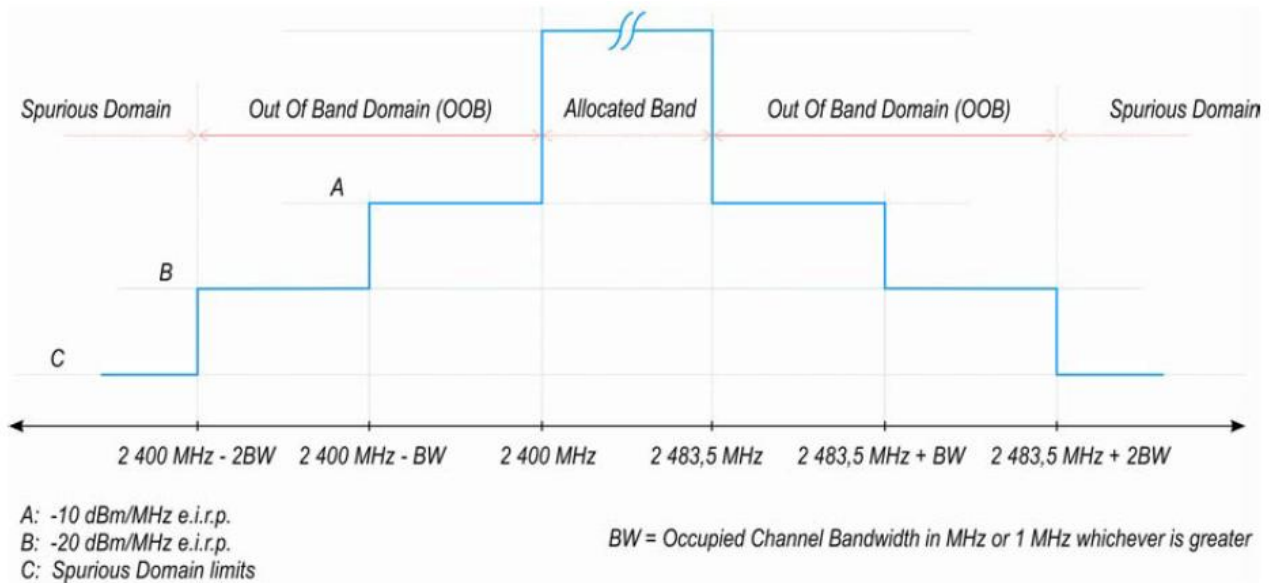

### 4.5.2 Test Procedure

Refer to chapter 5.3.9.2 of EN 300 328 V1.9.1.

Measurement Method	
<input checked="" type="checkbox"/> Conducted measurement	<input type="checkbox"/> Radiated measurement

### 4.5.3 Deviation from Test Standard

No deviation

### 4.5.4 Test Setup

The measurement was performed at normal environmental conditions only. This measurement was performed at the lowest and the highest channel. The equipment was configured to operate under its worst case situation with respect to output power. In case of conducted measurements the transmitter shall be connected to the measuring equipment via a suitable attenuator. The frequency has to be recorded for the right and left end above threshold of highest and lowest channel respectively.

#### 4.5.5 Test Results

##### 802.11b

Channel Frequency		2412 MHz				2472 MHz			
Test Condition		OOB Emission (MHz)				OOB Emission (MHz)			
		2385.05 ~ 2400		2370.1 ~ 2385.05		2483.5 ~ 2498.46		2498.46 ~ 2513.42	
		Freq. (MHz)	Power (dBm/ MHz)	Freq. (MHz)	Power (dBm/ MHz)	Freq. (MHz)	Power (dBm/ MHz)	Freq. (MHz)	Power (dBm/ MHz)
T <sub>nom</sub> +25°C	V <sub>nom</sub> (V)	2400.00	-30.72	2385.05	-46.31	2483.50	-29.46	2498.46	-45.33
Limit (dBm/MHz)		-10.00		-20.00		-10.00		-20.00	
Pass/Fail		Pass		Pass		Pass		Pass	

##### 802.11g

Channel Frequency		2412 MHz				2472 MHz			
Test Condition		OOB Emission (MHz)				OOB Emission (MHz)			
		2383.52 ~ 2400		2367.04 ~ 2383.52		2483.5 ~ 2499.98		2499.98 ~ 2516.46	
		Freq. (MHz)	Power (dBm/ MHz)	Freq. (MHz)	Power (dBm/ MHz)	Freq. (MHz)	Power (dBm/ MHz)	Freq. (MHz)	Power (dBm/ MHz)
T <sub>nom</sub> +25°C	V <sub>nom</sub> (V)	2400.00	-22.96	2383.52	-45.34	2483.50	-20.89	2499.98	-45.33
Limit (dBm/MHz)		-10.00		-20.00		-10.00		-20.00	
Pass/Fail		Pass		Pass		Pass		Pass	



802.11n (20MHz)

Channel Frequency		2412 MHz				2472 MHz			
Test Condition		OOB Emission (MHz)				OOB Emission (MHz)			
		2382.37 ~ 2400		2364.74 ~ 2382.37		2483.5 ~ 2501.18		2501.18 ~ 2518.86	
		Freq. (MHz)	Power (dBm/ MHz)	Freq. (MHz)	Power (dBm/ MHz)	Freq. (MHz)	Power (dBm/ MHz)	Freq. (MHz)	Power (dBm/ MHz)
T <sub>nom</sub> +25°C	V <sub>nom</sub> (V)	2400.00	-22.11	2382.37	-44.67	2483.50	-19.13	2501.18	-44.60
Limit (dBm/MHz)		-10.00		-20.00		-10.00		-20.00	
Pass/Fail		Pass		Pass		Pass		Pass	

802.11n (40MHz)

Channel Frequency		2422 MHz				2462 MHz			
Test Condition		OOB Emission (MHz)				OOB Emission (MHz)			
		2363.68 ~ 2400		2327.36 ~ 2363.68		2483.5 ~ 2519.98		2519.98 ~ 2556.46	
		Freq. (MHz)	Power (dBm/ MHz)	Freq. (MHz)	Power (dBm/ MHz)	Freq. (MHz)	Power (dBm/ MHz)	Freq. (MHz)	Power (dBm/ MHz)
T <sub>nom</sub> +25°C	V <sub>nom</sub> (V)	2400.00	-30.24	2363.68	-46.16	2483.50	-26.25	2519.98	-46.11
Limit (dBm/MHz)		-10.00		-20.00		-10.00		-20.00	
Pass/Fail		Pass		Pass		Pass		Pass	

## 4.6 Transmitter Spurious Emissions

### 4.6.1 Limits of Transmitter Spurious Emissions

Frequency Range	Maximum Power Limit	Bandwidth
30 MHz to 47 MHz	-36dBm	100kHz
47 MHz to 74 MHz	-54dBm	100kHz
74 MHz to 87,5 MHz	-36dBm	100kHz
87,5 MHz to 118 MHz	-54dBm	100kHz
118 MHz to 174 MHz	-36dBm	100kHz
174 MHz to 230 MHz	-54dBm	100kHz
230 MHz to 470 MHz	-36dBm	100kHz
470 MHz to 862 MHz	-54dBm	100kHz
862 MHz to 1 GHz	-36dBm	100kHz
1GHz ~ 12.75GHz	-30dBm	1MHz

### 4.6.2 Test Procedure

Refer to chapter 5.3.10.2 of EN 300 328 V1.9.1.

Measurement Method	
<input type="checkbox"/> Conducted measurement	<input checked="" type="checkbox"/> Radiated measurement
<p><u>For Conducted measurement:</u></p> <p>The level of unwanted emissions shall be measured as their power in a specified load (conducted spurious emissions) and their effective radiated power when radiated by the cabinet or structure of the equipment with the antenna connector(s) terminated by a specified load (cabinet radiation).</p>	
<p><u>Conducted measurement (For equipment with multiple transmit chains):</u></p> <p><input type="checkbox"/> Option 1: The results for each of the transmit chains for the corresponding 1MHz segments shall be added and compared with the limits.</p> <p><input type="checkbox"/> Option 2: The results for each of the transmit chains shall be individually compared with the limits after these limits have been reduced by <math>10 \times \log(N)</math> (number of active transmit chains)</p>	

### 4.6.3 Deviation from Test Standard

No deviation.

### 4.6.4 Test Setup

1. For the actual test configuration, please refer to the related Item in this test report (Photographs of the Test Configuration).
2. The equipment was configured to operate under its worst case situation with respect to output power.
3. The measurement was performed at normal environmental conditions only. Controlling software has been activated to set the EUT on specific status.
4. This measurement was performed at the lowest and the highest channel.

#### 4.6.5 Test Results

#### BELOW 1GHz WORST-CASE DATA

#### 802.11b

<b>SPURIOUS EMISSION FREQUENCY RANGE</b>	30MHz ~ 1GHz	<b>OPERATING CHANNEL</b>	1
--	--------------	--------------------------	---

SPURIOUS EMISSION LEVEL				
Frequency (MHz)	Antenna Polarization	Level (dBm)	Limit (dBm)	Margin (dB)
53.40	H	-71.73	-54.00	-17.73
59.95	V	-66.75	-54.00	-12.75
82.50	V	-63.26	-36.00	-27.26
115.72	H	-72.13	-54.00	-18.13
499.96	V	-67.97	-54.00	-13.97
501.66	H	-71.73	-54.00	-17.73
599.87	H	-62.55	-54.00	-8.55
600.00	V	-63.99	-54.00	-9.99
699.91	V	-65.55	-54.00	-11.55
714.09	H	-66.14	-54.00	-12.14
799.94	H	-68.39	-54.00	-14.39
800.06	V	-69.07	-54.00	-15.07

**ABOVE 1GHz WORST-CASE DATA**
**802.11b**

<b>SPURIOUS EMISSION FREQUENCY RANGE</b>	1GHz ~ 12.75GHz	<b>OPERATING CHANNEL</b>	1, 13
--	-----------------	--------------------------	-------

<b>SPURIOUS EMISSION LEVEL</b>					
<b>Channel</b>	<b>Frequency (MHz)</b>	<b>Antenna Polarization</b>	<b>Level (dBm)</b>	<b>Limit (dBm)</b>	<b>Margin (dB)</b>
1	4824.08	V	-44.52	-30.00	-14.52
	4824.10	H	-45.86	-30.00	-15.86
13	4943.80	H	-47.29	-30.00	-17.29
	4944.00	V	-48.64	-30.00	-18.64

## Receiver Parameters

### 4.7 Receiver Spurious Radiation

#### 4.7.1 Limit of Receiver Spurious Radiation

Frequency Range	Maximum Power Limit	Bandwidth
30 MHz ~ 1 GHz	-57dBm	100kHz
1 GHz ~ 12.75 GHz	-47dBm	1MHz

#### 4.7.2 Test Procedure

Refer to chapter 5.3.11.2 of EN 300 328 V1.9.1.

Measurement Method	
<input type="checkbox"/> Conducted measurement	<input checked="" type="checkbox"/> Radiated measurement
<p><u>For Conducted measurement:</u></p> <p>The level of unwanted emissions shall be measured as their power in a specified load (conducted spurious emissions) and their effective radiated power when radiated by the cabinet or structure of the equipment with the antenna connector(s) terminated by a specified load (cabinet radiation).</p>	
<p><u>Conducted measurement (For equipment with multiple transmit chains):</u></p> <p><input type="checkbox"/> Option 1: The results for each of the transmit chains for the corresponding 1MHz segments shall be added and compared with the limits.</p> <p><input type="checkbox"/> Option 2: The results for each of the transmit chains shall be individually compared with the limits after these limits have been reduced by <math>10 \times \log(N)</math> (number of active transmit chains)</p>	

#### 4.7.3 Deviation from Test Standard

No deviation.

#### 4.7.4 Test Setup

1. For the actual test configuration, please refer to the related Item in this test report (Photographs of the Test Configuration).
2. Testing was performed when the equipment was in a receive-only mode.
3. The measurement was performed at normal environmental conditions only. Controlling software has been activated to set the EUT on specific status.
4. This measurement was performed at the lowest and the highest channel.

#### 4.7.5 Test Results

##### RX BELOW 1GHz WORST-CASE DATA

<b>SPURIOUS EMISSION FREQUENCY RANGE</b>	30MHz ~ 1GHz	<b>OPERATING CHANNEL</b>	1
--	--------------	--------------------------	---

SPURIOUS EMISSION LEVEL				
Frequency (MHz)	Antenna Polarization	Level (dBm)	Limit (dBm)	Margin (dB)
52.80	H	-72.31	-57.00	-15.31
82.50	V	-62.99	-57.00	-5.99
114.87	H	-71.58	-57.00	-14.58
254.56	V	-79.27	-57.00	-22.27
391.45	H	-77.13	-57.00	-20.13
500.09	V	-68.42	-57.00	-11.42
599.87	V	-63.27	-57.00	-6.27
600.36	H	-64.65	-57.00	-7.65
700.15	V	-66.67	-57.00	-9.67
800.18	H	-69.04	-57.00	-12.04
959.99	V	-69.77	-57.00	-12.77
960.23	H	-63.67	-57.00	-6.67

**RX ABOVE 1GHz DATA**

<b>SPURIOUS EMISSION FREQUENCY RANGE</b>	1GHz ~ 12.75GHz	<b>OPERATING CHANNEL</b>	1, 13
--	-----------------	--------------------------	-------

<b>SPURIOUS EMISSION LEVEL</b>					
<b>Channel</b>	<b>Frequency (MHz)</b>	<b>Antenna Polarization</b>	<b>Level (dBm)</b>	<b>Limit (dBm)</b>	<b>Margin (dB)</b>
1	4824.01	V	-55.84	-47.00	-8.84
	4824.03	H	-56.27	-47.00	-9.27
13	4943.99	V	-55.95	-47.00	-8.95
	4944.02	H	-56.48	-47.00	-9.48

## 4.8 Receiver Blocking

### 4.8.1 Limit of Receiver Blocking

Adaptive equipment using wide band modulations other than FHSS, shall comply with the requirements defined in non-LBT based DAA or LBT based DAA in the presence of a blocking signal with characteristics as provided in below table.

Equipment Type (LBT / Non- LBT)	Wanted signal Mean Power from Companion Device	Blocking Signal Frequency (MHz)	Blocking Signal Power (dBm)	Type of Interfering Signal
LBT	sufficient to maintain the link (see note 2)	2 395 or 2 488.5 (see note 1)	-35	CW
Non-LBT	-30 dBm			

NOTE 1: The highest blocking frequency shall be used for testing the lowest operating hopping frequency, while the lowest blocking frequency shall be used for testing the highest hopping frequency.

NOTE 2: A typical value which can be used in most cases is -50 dBm/MHz.

### 4.8.2 Test Procedure

Refer to chapter 5.3.7.2.1. of EN 300 328 V1.9.1.

Measurement Method	
<input checked="" type="checkbox"/> Conducted measurement	<input type="checkbox"/> Radiated measurement

### 4.8.3 Deviation from Test Standard

No deviation.

#### 4.8.4 Test Setup Configuration

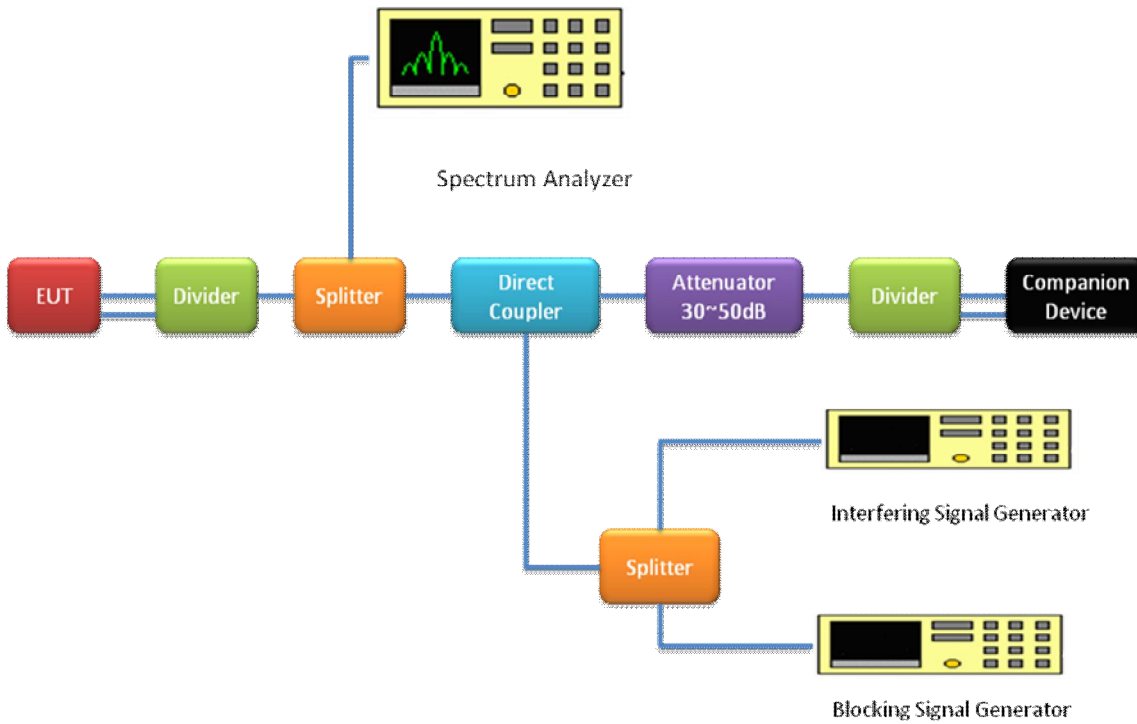

#### 4.8.5 Test Results

- Not applicable to non-adaptive equipment or adaptive equipment operating in a non-adaptive mode
- Not applicable due to the RF Output power is less than 10 dBm e.i.r.p.
- Refer to below test result

#### 802.11b

Channel	Channel Frequency (MHz)	Wanted Signal Mean Power from Companion Device (dBm/MHz)	Blocking Signal Frequency (MHz)	Blocking Signal Power (dBm)	Pass/Fail
1	2412	-50	2488.5	-30	Pass
13	2472	-50	2395	-30	Pass

#### 802.11g

Channel	Channel Frequency (MHz)	Wanted Signal Mean Power from Companion Device (dBm/MHz)	Blocking Signal Frequency (MHz)	Blocking Signal Power (dBm)	Pass/Fail
1	2412	-50	2488.5	-30	Pass
13	2472	-50	2395	-30	Pass

#### 802.11n (20MHz)

Channel	Channel Frequency (MHz)	Wanted Signal Mean Power from Companion Device (dBm/MHz)	Blocking Signal Frequency (MHz)	Blocking Signal Power (dBm)	Pass/Fail
1	2412	-50	2488.5	-30	Pass
13	2472	-50	2395	-30	Pass

#### 802.11n (40MHz)

Channel	Channel Frequency (MHz)	Wanted Signal Mean Power from Companion Device (dBm/MHz)	Blocking Signal Frequency (MHz)	Blocking Signal Power (dBm)	Pass/Fail
3	2422	-50	2488.5	-30	Pass
11	2462	-50	2395	-30	Pass

## 5 Photographs of the Test Configuration

### TX / RX SPURIOUS EMISSION TEST

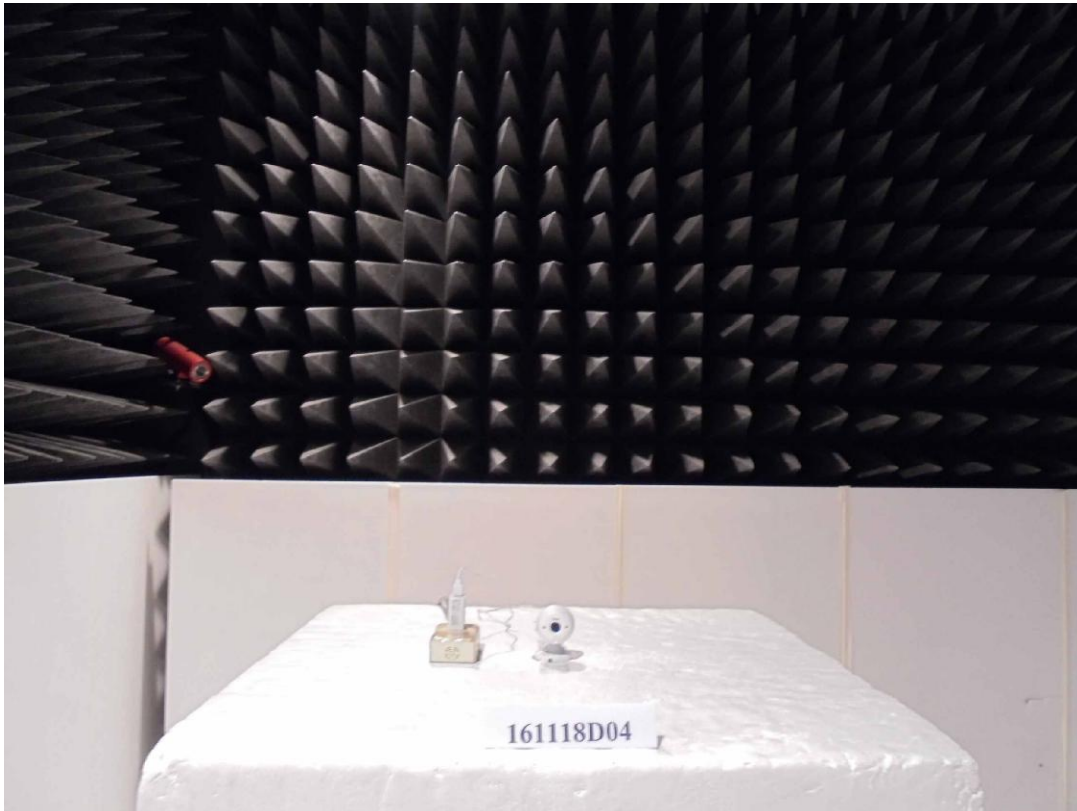

### TX / RX SPURIOUS EMISSION TEST

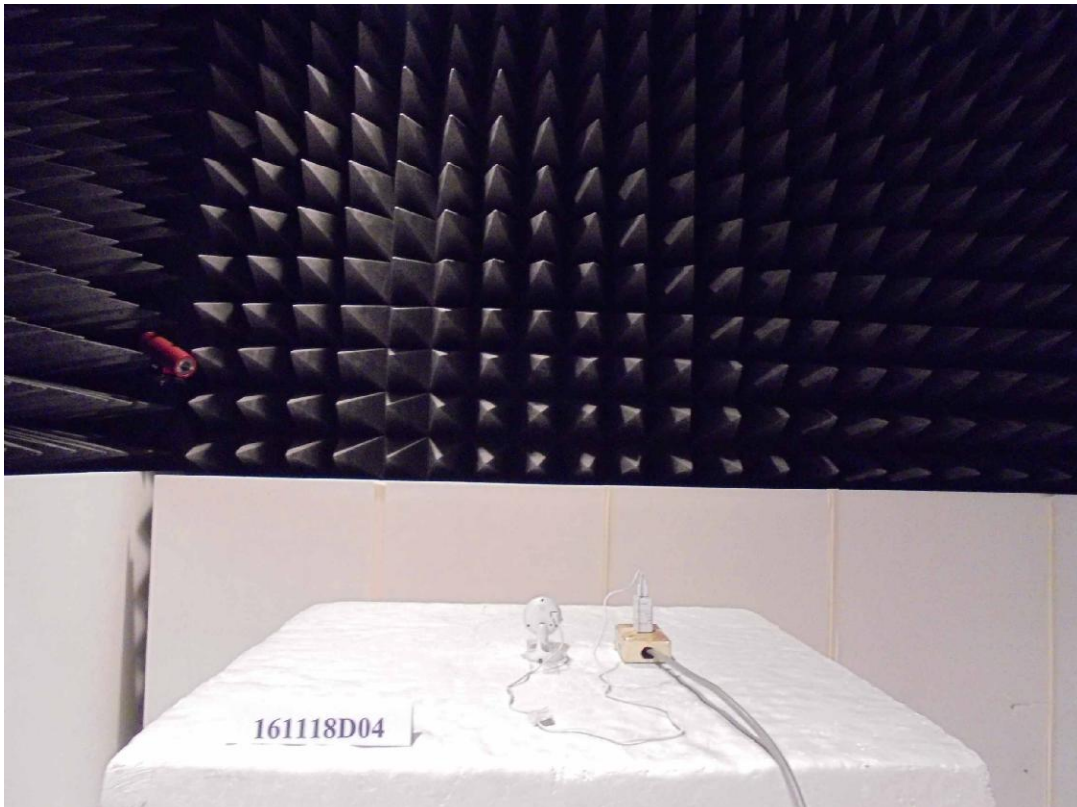

## Appendix - Information on the Testing Laboratories

We, Bureau Veritas Consumer Products Services (H.K.) Ltd., Taoyuan Branch, were founded in 1988 to provide our best service in EMC, Radio, Telecom and Safety consultation. Our laboratories are accredited and approved according to ISO/IEC 17025.

If you have any comments, please feel free to contact us at the following:

**Linko EMC/RF Lab**

Tel: 886-2-26052180

Fax: 886-2-26051924

**Hsin Chu EMC/RF/Telecom Lab**

Tel: 886-3-6668565

Fax: 886-3-6668323

**Hwa Ya EMC/RF/Safety Lab**

Tel: 886-3-3183232

Fax: 886-3-3270892

**Email:** [service.adt@tw.bureauveritas.com](mailto:service.adt@tw.bureauveritas.com)

**Web Site:** [www.bureauveritas-adt.com](http://www.bureauveritas-adt.com)

The address and road map of all our labs can be found in our web site also.

--- END ---