



FCC SDoC Test Report

Issued date: Jul. 05, 2019

Project No.: 19Q052009

Product : Network Camera

Model : SD9362-EH V2

Applicant : VIVOTEK INC.

Address : 6F, No.192, Lien-Cheng Rd., Chung-Ho , New Taipei City, 235,
Taiwan, R.O.C.

Report No: WD-EF-R-190417-A0

According to

47 CFR FCC Part 15, Subpart B, Class A
ICES-003: 2016 Issue 6, Class A

ANSI C63.4: 2014

Authorized Signatory :  / Ken Huang



Wendell Industrial Co., Ltd
Wendell Electrical Testing Lab.

Add: 6F/6F-1, No.188, Baoqiao Rd., Xindian Dist., New Taipei City 23145, Taiwan R.O.C.



Table of Contents

1	Certification	5
1.1	Summary of Test Result	6
2	Test Configuration of Equipment Under Test	7
2.1	Test Facility	7
2.2	Measurement Uncertainty	8
2.2.1	Conducted Emission test	8
2.2.2	Radiated Emission test	8
3	Generation Information	9
3.1	Description of EUT	9
3.2	Description of Test Modes	10
3.3	EUT Operating Condition	11
3.4	Description of Support Unit.....	12
3.5	Configuration of System Under Test	13
4	Emission Test	14
4.1	Conducted Emission Measurement (Frequency Range 150 KHz-30MHz)	14
4.1.1	Limit of Conducted Emission Measurement	14
4.1.2	Test Instrument	15
4.1.3	Test Procedure	16
4.1.4	Deviation from Test Standard.....	16
4.1.5	Test Setup	17
4.1.6	Test Result	18
4.1.7	Photographs of Test Configuration	22
4.2	Radiated Emission Measurement	24
4.2.1	Limits of Radiated Emission Measurement	24
4.2.2	Test Instrument	26
4.2.3	Test Procedure	27
4.2.4	Deviation from Test Standard.....	27
4.2.5	Test Setup	28
4.2.6	Test Result	29
4.2.7	Photographs of Test Configuration	41



History of this test report

Report No.	Issue date	Description
WD-EF-R-190417-A0	Jul. 05, 2019	Initial Issue

Declaration

This report is for your exclusive use. Any copying or replication of this report to or for any other person or entity, or use of our name or trademark, is permitted only with our prior written permission. This report sets forth our findings solely with respect to the test samples identified herein. The results set forth in this report are not indicative or representative of the quality or characteristics of the lot from which a test sample was taken or any similar or identical product unless specifically and expressly noted. Our report includes all of the tests requested by you and the results thereof based upon the information that you provided to us.



History of supplementary report

Report No.	Issue date	Description
WD-EF-R-190417-A0	Jul. 05, 2019	Original report

Declaration

This report is for your exclusive use. Any copying or replication of this report to or for any other person or entity, or use of our name or trademark, is permitted only with our prior written permission. This report sets forth our findings solely with respect to the test samples identified herein. The results set forth in this report are not indicative or representative of the quality or characteristics of the lot from which a test sample was taken or any similar or identical product unless specifically and expressly noted. Our report includes all of the tests requested by you and the results thereof based upon the information that you provided to us.



1 Certification

Product: Network Camera

Brand Name: VIVOTEK

Model: SD9362-EH V2

Applicant: VIVOTEK INC.

Tested: Jun. 12 ~ Jun. 14, 2019

Standard: 47 CFR FCC Part 15, Subpart B, Class A

ICES-003: 2016 Issue 6, Class A

ANSI C63.4: 2014

The above equipment (Model: SD9362-EH V2) has been tested by **Wendell Electrical Testing Lab.**, and found compliance with the requirement of the above standards. The test record, data evaluation and Equipment Under Test (EUT) configurations represented herein are true and accurate accounts of the measurements of the sample's EMC characteristics under the conditions specified in this report.

Please note that the measurement uncertainty are provided for informational purpose only and are not used in determining the Pass/Fail results.



1.1 Summary of Test Result

The EUT has been tested according to the following specifications:

Emission				
Standard	Test Item	Limit	Result	Remark
47 CFR FCC Part 15, Subpart B	Conducted disturbance at mains terminals	Class A	Pass	Meets the requirements
ICES-003	Radiated disturbance	Class A	Pass	Meets the requirements

Note: Test record contained in the referenced test report relate only to the EUT sample and test item.



2 Test Configuration of Equipment Under Test

2.1 Test Facility

Conducted disturbance at mains terminals Test

W01: 5F-1, No.188, Baoqiao Rd., Xindian Dist., New Taipei City 23145, Taiwan (R.O.C.)

Radiated emission (9*6*6 Chamber) and Conducted disturbance at mains terminals Tests

W06: No.67-9, Shimen Rd., Tucheng Dist., New Taipei City 23654, Taiwan (R.O.C.)

ACCREDITATIONS

The laboratories are accredited and approved by the TAF according to ISO/IEC 17025.



2.2 Measurement Uncertainty

The measurement instrumentation uncertainty consideration contained in CISPR 16-4-2.

This uncertainty represents an expanded uncertainty expressed at approximately the 95% confidence level using a coverage factor of $k=2$.

Please note that the measurement uncertainty are provided for informational purpose only and are not used in determining the Pass/Fail results.

2.2.1 Conducted Emission test

Test Site	Measurement Freq. Range	dB (U_{cispr})	Note
W01	150 kHz ~ 30 MHz	2.43	N/A
W06	150 kHz ~ 30 MHz	2.52	N/A

2.2.2 Radiated Emission test

Test Site	Measurement Freq. Range	Ant	dB (U_{cispr})	Note
W06	30 MHz ~ 200 MHz	V	3.16	N/A
	30 MHz ~ 200 MHz	H	2.46	N/A
	200 MHz ~ 1000 MHz	V	4.72	N/A
	200 MHz ~ 1000 MHz	H	3.01	N/A
	1 GHz ~ 6 GHz	V	5.04	N/A
	1 GHz ~ 6 GHz	H	4.92	N/A
	6 GHz ~ 18 GHz	V	5.22	N/A
	6 GHz ~ 18 GHz	H	5.16	N/A
	18 GHz ~ 40 GHz	V	4.68	N/A
	18 GHz ~ 40 GHz	H	4.92	N/A



3 Generation Information

3.1 Description of EUT

Product	Network Camera
Brand	VIVOTEK
Model	SD9362-EH V2
Applicant	VIVOTEK INC.
Received date	May 21, 2019
EUT Power Rating	24 Vac (from AC-AC adapter) or 24 Vdc (from AC-DC adapter) or 55Vdc (from PoE)
Model Differences	N/A
Operating System	N/A
Data Cable Supplied	N/A
Accessory Device	N/A
I/O Port	Please refer to the User's Manual

Note:

1. The EUT's highest operating frequency is 1866MHz. Therefore the radiated emission is tested up to 10GHz.

3.2 Description of Test Modes

For conducted emission, the EUT has been pre-tested under the following test modes, and **test mode 1 and 4** was the worst case for final test.

Test Mode	Test Condition
1	AC-AC Adapter - night mode
2	AC-AC Adapter - day mode
3	AC-DC Adapter - night mode
4	AC-DC Adapter - day mode

For radiated emission, the EUT has been pre-tested under the following test modes, and **test mode 1 and 3 and 5** was the worst case for final test.

Test Mode	Test Condition
1	AC-AC Adapter - night mode
2	AC-AC Adapter - day mode
3	AC-DC Adapter - night mode
4	AC-DC Adapter - day mode
5	PoE - night mode
6	PoE - day mode

Test results are presented in the report as below.

Test Result	Test Condition
Conducted emission test	
A	AC-AC Adapter - night mode
B	AC-DC Adapter - day mode
Radiated emission 30MHz ~ 1GHz test	
A	AC-AC Adapter - night mode
B	AC-DC Adapter - night mode
C	PoE - night mode
Radiated emission above 1GHz test	
A	AC-AC Adapter - night mode
B	AC-DC Adapter - night mode
C	PoE - night mode

3.3 EUT Operating Condition

Mode A & B

- a. Placed the EUT on the test table.
- b. Prepare server PC to act as a communication partner and placed it outside of testing area.
- c. The EUT was connected to the server PC with LAN cable.
- d. The communication partner sent data to EUT by command "ping" via LAN.
- e. The EUT sent video signal to server PC via LAN cable.
- f. The server PC show IPCAM's image on browser.
- g. The Microphone sent voice signal to EUT.
- h. The EUT sent voice signal to earphone.
- i. The EUT write data with Micro SD card.

Mode C

- a. Placed the EUT on the test table.
- b. Prepare server PC and PoE injector to act as a communication partner and placed it outside of testing area.
- c. The EUT was connected to the server PC via LAN and PoE.
- d. The communication partner sent data to EUT by command "ping" via LAN.
- e. The EUT sent video signal to server PC via LAN cable.
- f. The server PC show IPCAM's image on browser.
- g. The Microphone sent voice signal to EUT.
- h. The EUT sent voice signal to earphone.
- j. The EUT write data with Micro SD card.



3.4 Description of Support Unit

The EUT has been conducted testing with other necessary accessories or support units.

Item	Equipment	Brand	Model No.	Serial No.	FCC ID	Data Cable	Power Cord	Remark
1	Desktop PC	DELL	D19M	N/A	PPD-QCN FA335	20m non-shielded CAT.5E RJ45 cable (Mode A & B) 1m non-shielded CAT.5E RJ45 cable (Mode C)	1.8m non-shielded cable	-
2	POE	CISCO	MA-INJ-4	N/A	N/A	20m non-shielded CAT.5E RJ45 cable	1.8m non-shielded cable	Supplied by client
3	Earphone & Microphone	E-books	E-EPA057	N/A	N/A	1.4m non-shielded cable	N/A	-
4	MicroSD Card	ADATA	16GB	N/A	N/A	N/A	N/A	-
5	adapter	N/A	TAA66-2403 500E	N/A	N/A	1m non-shielded cable	1.8m non-shielded cable	Supplied by client
6	adapter	N/A	TAA66-2403 500AU	N/A	N/A	1m non-shielded cable	1.8m non-shielded cable	Supplied by client
7	adapter	MW	MDR-60-24	N/A	N/A	1m non-shielded cable	1.8m non-shielded cable	Supplied by client
8	Grounding cable	N/A	N/A	N/A	N/A	1m non-shielded cable	N/A	-

- Note:**
1. The core(s) is(are) originally attached to the cable(s).
 2. Item 1-2 acted as communication partners to transfer data.
 3. The EUT uses the follow adapter and POE:

AC-AC Adapter (Support Unit)	
Model	TAA66-2403500AU
Input Power	120Vac, 60Hz
Output Power	24Vac, 3.5A, 87W
Power line	Input: 1.8m non-shielded cable Output: 1m non-shielded cable

AC-DC Adapter (Support Unit)	
Brand	MW
Model	MDR-60-24
Input Power	100-240Vac, 50/60Hz, 1.8A
Output Power	24Vdc, 2.5A
Power line	Input: 1.8m non-shielded cable Output: 1m non-shielded cable

PoE injector (Support Unit)	
Brand	CISCO
Model	MA-INJ-4
Input Power	100-240Vac, 50/60Hz, 0.67A
Output Power	55Vdc, 0.6A

3.5 Configuration of System Under Test

Mode A & B

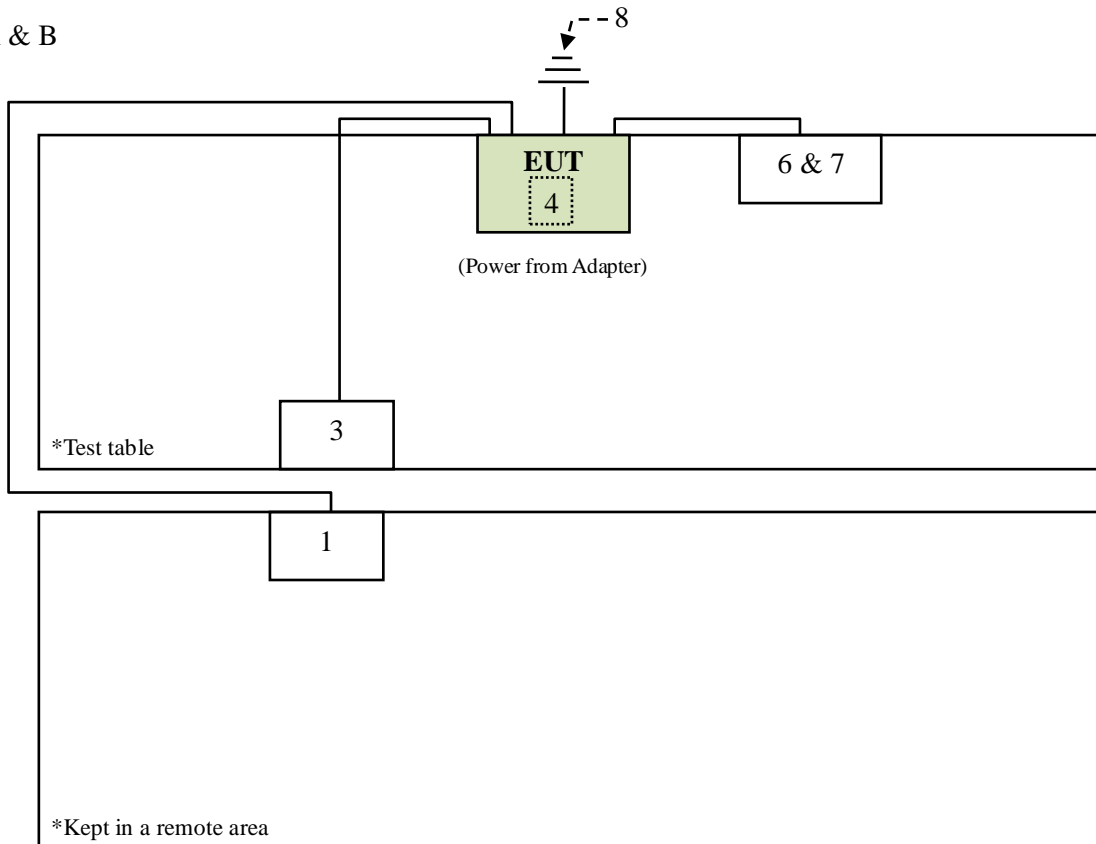

Mode C

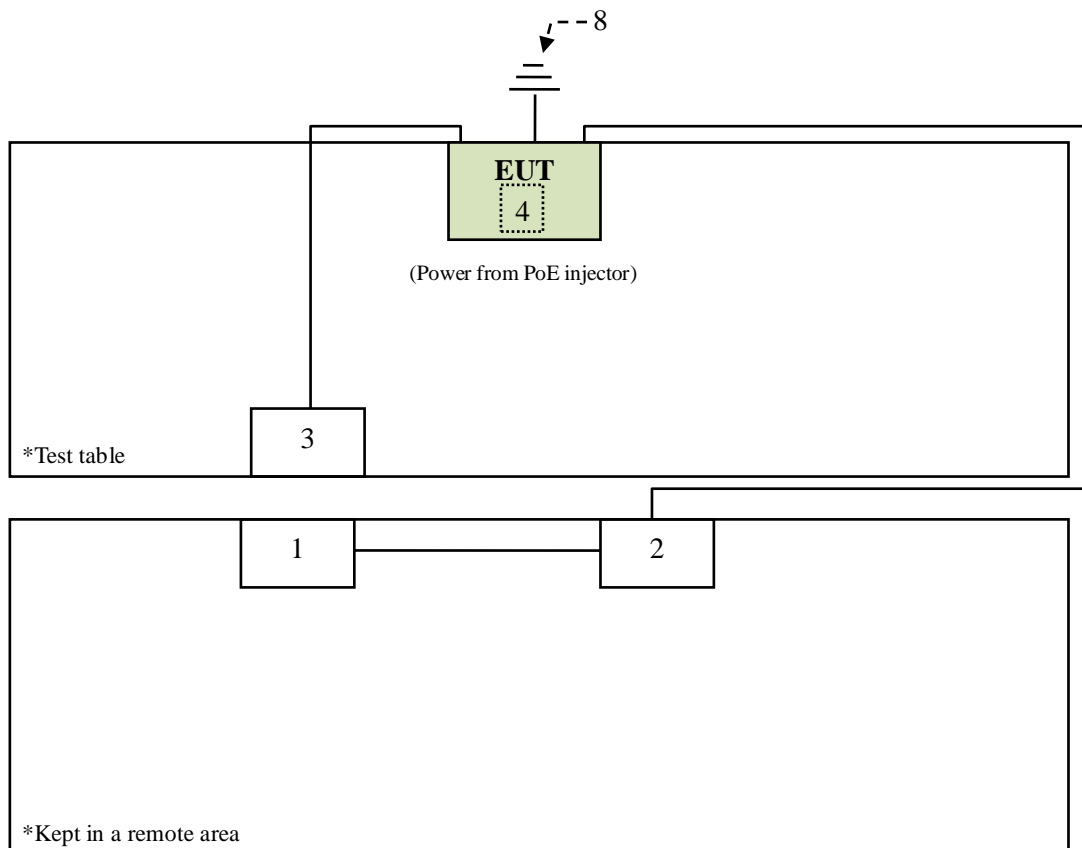



4 Emission Test

4.1 Conducted Emission Measurement (Frequency Range 150 KHz-30MHz)

4.1.1 Limit of Conducted Emission Measurement

Frequency (MHz)	Class A (dBuV)		Class B (dBuV)	
	Quasi-peak	Average	Quasi-peak	Average
0.15 to 0.5	79	66	66 to 56	56 to 46
0.50 to 5.0	73	60	56	46
5.0 to 30.0	73	60	60	50

- Note:**
1. The lower limit shall apply at the transition frequencies.
 2. The limit decreases in line with the logarithm of the frequency in the range of 0.15 to 0.50 MHz.
 3. Detector function in the form: PK = Peak, QP = Quasi Peak, AV = Average
 4. The test result calculated as following:
Measurement Value = Reading Level + Correct Factor
Correction Factor = Insertion loss of LISN + Cable loss + Transient Limiter (If use)
Margin Level = Measurement Value –Limit Value



4.1.2 Test Instrument

Test Site: W01-CE					
Item	Equipment	Manufacturer	Model	Meter No.	Calibration Date
1	TWO-LINE V-NETWORK	R&S	ENV216	CT-1-025-1	Apr. 29, 2019
2	Pulse limiter	R&S®	ESH3-Z2	CT-2-015	Apr. 25, 2019
3	EMI Test Receiver	R&S	ESCI	CT-1-024	Apr. 24, 2019
4	V-LISN	Schwarzbeck	NSLK8127	CT-1-104-1	Apr. 30, 2019
5	Test Cable	Marvelous Microwave Inc	200200.400LL .500A	CT-10-048-1	Apr. 25, 2019
6	50ohm Termination	N/A	N/A	CT-1-065-1	Apr. 25, 2019
7	Measurement Software	EZ-EMC	Ver: FA-03A	CT-3-012	No calibration request

Note: 1. The calibration interval of the above test instruments is 12 months.

Test Site: W06-CE					
Item	Equipment	Manufacturer	Model	Meter No.	Calibration Date
1	TWO-LINE V-NETWORK	R&S	ENV216	CT-1-025-2	May 20, 2019
2	Transient Limiter	Electro Metrics	EM-7600	CT-1-026	May 16, 2019
3	EMI Test Receiver	R&S	ESR3	CT-1-103	May 16, 2019
4	V-LISN	Schwarzbeck	NSLK8127RC	CT-1-104-1RC	May 20, 2019
5	Test Cable	EMCI	EMCCFD300-BM-BM-5000	CT-1-107-2	May 16, 2019
6	50ohm Termination	HUBER+SUHNE R	N/A	CT-1-109-1	May 13, 2019
7	Measurement Software	EZ-EMC	Ver: FA-03A	CT-3-012	No calibration request

Note: 1. The calibration interval of the above test instruments is 12 months.



4.1.3 Test Procedure

- a. The EUT was placed 0.8 meter height wooden table from the horizontal ground plane with EUT being connected to power source through a line impedance stabilization network (LISN). The LISN at least be 80 cm from nearest chassis of EUT.
- b. The line impedance stabilization network (LISN) provides 50 ohm/50uH of coupling impedance for the measuring instrument. All other support equipments powered from additional LISN(s).
- c. Interrelating cables that hang closer than 40 cm to the ground plane shall be folded back and forth in the center forming a bundle. All I/O cables were positioned to simulate typical usage.
- d. All I/O cables that are not connected to a peripheral shall be bundle in the center. The end of the cable may be terminated, if required, using the correct terminating impedance. The overall length shall not exceed 1 m.
- e. The EMI test receiver connected to LISN powering the EUT. The actual test configuration, please refer to EUT test photos.
- f. The receiver scanned from 150kHz to 30MHz for emissions in each of test modes. A scan was taken on both power lines, Line and Neutral, recording at least six highest emissions.
- g. The EUT and cable configuration of the above highest emission levels were recorded. The test data of the worst case was recorded.

4.1.4 Deviation from Test Standard

No deviation

4.1.5 Test Setup

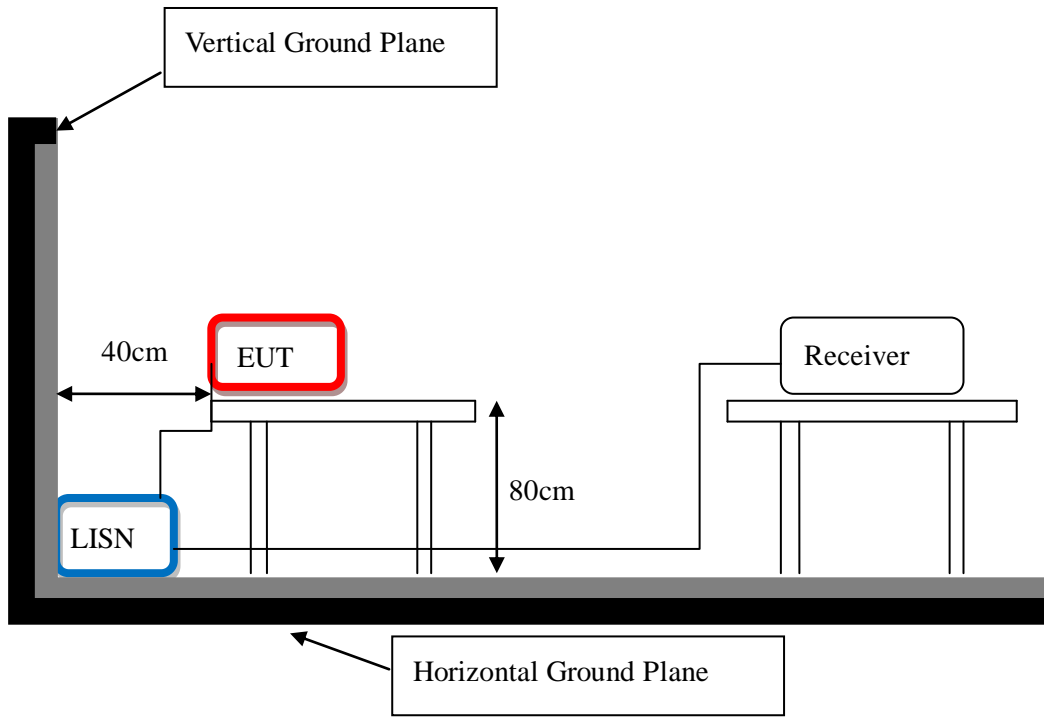

Note: Please refer to 4.1.7 for the actual test configuration.



4.1.6 Test Result

Test Voltage	120Vac, 60Hz	Frequency Range	0.15-30 MHz
Environmental Conditions	23°C, 68% RH	6dB Bandwidth	9 kHz
Test Date	2019/06/12	Phase	L
Tested by	Duncan Cheng	Test Site	W06
Test Mode	A		

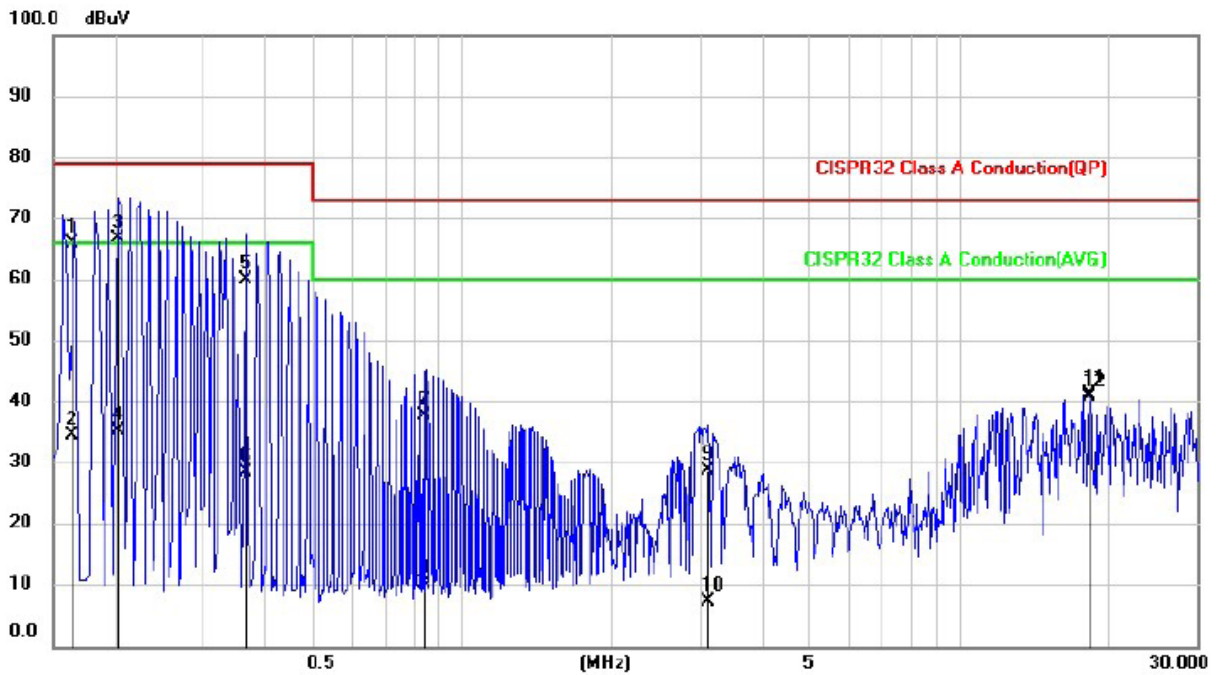

No.	Frequency (MHz)	Reading Level (dBUV)	Correct Factor (dB)	Measurement (dBUV)	Limit (dBUV)	Margin (dB)	Detector
1	0.1628	56.15	9.81	65.96	79.00	-13.04	QP
2	0.1628	24.51	9.81	34.32	66.00	-31.68	AVG
3	0.2017	56.82	9.81	66.63	79.00	-12.37	QP
4	0.2017	25.33	9.81	35.14	66.00	-30.86	AVG
5	0.3681	50.05	9.81	59.86	79.00	-19.14	QP
6	0.3681	18.55	9.81	28.36	66.00	-37.64	AVG
7	0.8407	27.84	9.83	37.67	73.00	-35.33	QP
8	0.8407	0.26	9.83	10.09	60.00	-49.91	AVG
9	3.1227	18.83	9.92	28.75	73.00	-44.25	QP
10	3.1227	-2.89	9.92	7.03	60.00	-52.97	AVG
11	18.2433	30.88	10.25	41.13	73.00	-31.87	QP
12	18.2433	30.45	10.25	40.70	60.00	-19.30	AVG

Remark: 1. QP = Quasi Peak, AVG = Average
 2. Correction Factor = Insertion loss of LISN + Cable loss + Transient Limiter (If use)
 3. Measurement Value = Reading Level + Correct Factor
 4. Margin Level = Measurement Value - Limit Value



Test Voltage	120Vac, 60Hz	Frequency Range	0.15-30 MHz
Environmental Conditions	23°C, 68% RH	6dB Bandwidth	9 kHz
Test Date	2019/06/12	Phase	N
Tested by	Duncan Cheng	Test Site	W06
Test Mode	A		

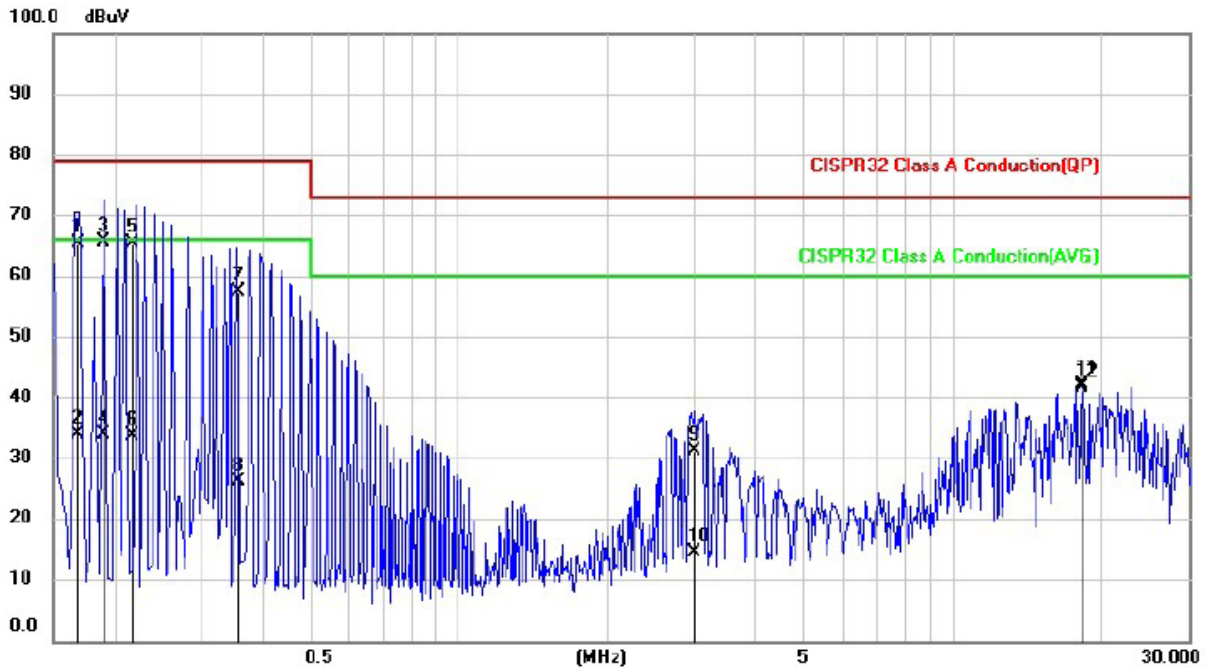

No.	Frequency (MHz)	Reading Level (dBuV)	Correct Factor (dB)	Measurement (dBuV)	Limit (dBuV)	Margin (dB)	Detector
1	0.1689	55.71	9.79	65.50	79.00	-13.50	QP
2	0.1689	23.99	9.79	33.78	66.00	-32.22	AVG
3	0.1911	55.89	9.79	65.68	79.00	-13.32	QP
4	0.1911	24.15	9.79	33.94	66.00	-32.06	AVG
5	0.2176	55.68	9.79	65.47	79.00	-13.53	QP
6	0.2176	23.96	9.79	33.75	66.00	-32.25	AVG
7	0.3558	47.63	9.79	57.42	79.00	-21.58	QP
8	0.3558	16.37	9.79	26.16	66.00	-39.84	AVG
9	2.9680	21.14	9.90	31.04	73.00	-41.96	QP
10	2.9680	4.38	9.90	14.28	60.00	-45.72	AVG
11	18.2433	32.00	10.19	42.19	73.00	-30.81	QP
12	18.2433	31.43	10.19	41.62	60.00	-18.38	AVG

Remark: 1. QP = Quasi Peak, AVG = Average
 2. Correction Factor = Insertion loss of LISN + Cable loss + Transient Limiter (If use)
 3. Measurement Value = Reading Level + Correct Factor
 4. Margin Level = Measurement Value - Limit Value



Test Voltage	120Vac, 60Hz	Frequency Range	0.15-30 MHz
Environmental Conditions	23°C, 68% RH	6dB Bandwidth	9 kHz
Test Date	2019/06/13	Phase	L
Tested by	Duncan Cheng	Test Site	W06
Test Mode	B		

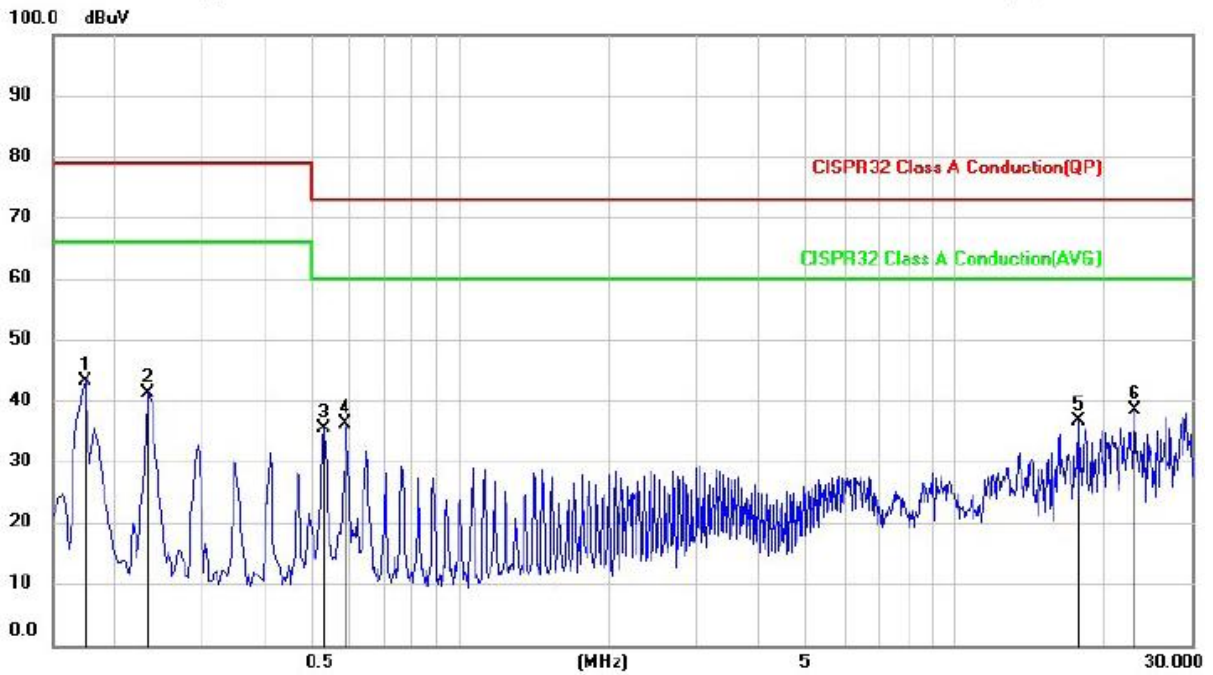

No.	Frequency (MHz)	Reading Level (dBuV)	Correct Factor (dB)	Measurement (dBuV)	Limit (dBuV)	Margin (dB)	Detector
1	0.1740	33.41	9.81	43.22	79.00	-35.78	peak
2	0.2340	31.29	9.81	41.10	79.00	-37.90	peak
3	0.5299	25.62	9.81	35.43	73.00	-37.57	peak
4	0.5860	26.24	9.82	36.06	73.00	-36.94	peak
5	17.6940	26.30	10.24	36.54	73.00	-36.46	peak
6	23.1299	28.04	10.37	38.41	73.00	-34.59	peak

Remark: 1. QP = Quasi Peak, AVG = Average
 2. Correction Factor = Insertion loss of LISN + Cable loss + Transient Limiter (If use)
 3. Measurement Value = Reading Level + Correct Factor
 4. Margin Level = Measurement Value - Limit Value



Test Voltage	120Vac, 60Hz	Frequency Range	0.15-30 MHz
Environmental Conditions	23°C, 68% RH	6dB Bandwidth	9 kHz
Test Date	2019/06/13	Phase	N
Tested by	Duncan Cheng	Test Site	W06
Test Mode	B		

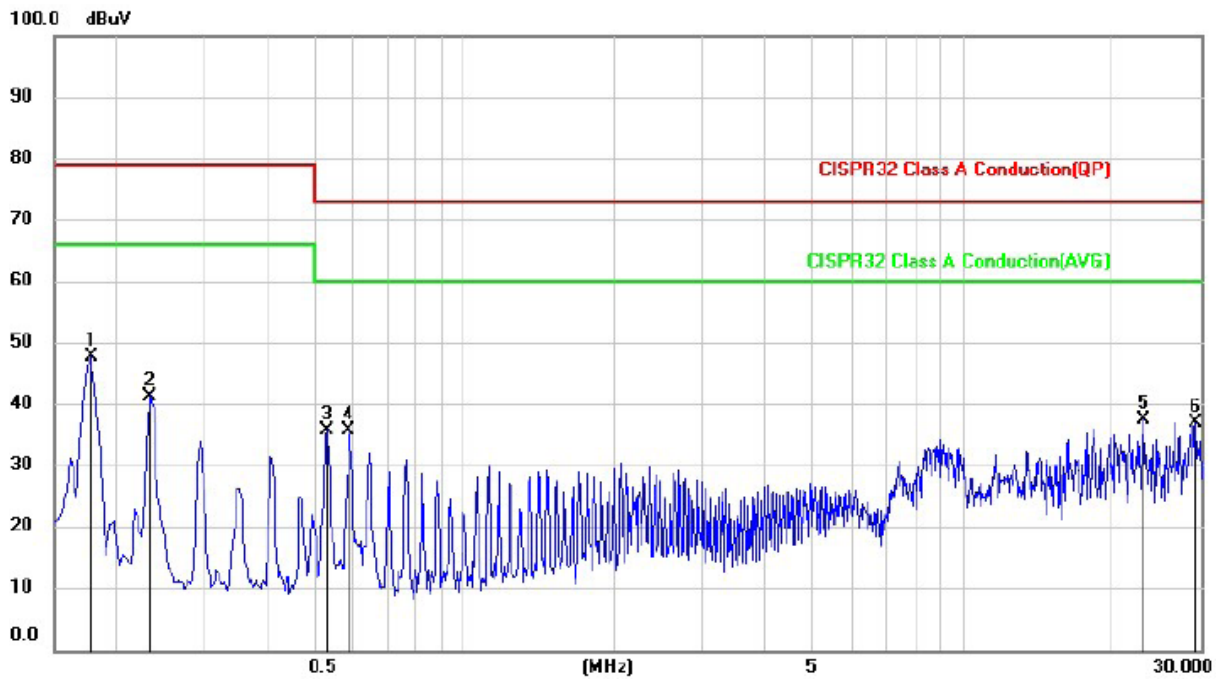

No.	Frequency (MHz)	Reading Level (dBuV)	Correct Factor (dB)	Measurement (dBuV)	Limit (dBuV)	Margin (dB)	Detector
1	0.1780	37.82	9.79	47.61	79.00	-31.39	peak
2	0.2340	31.33	9.79	41.12	79.00	-37.88	peak
3	0.5299	25.85	9.79	35.64	73.00	-37.36	peak
4	0.5860	25.78	9.79	35.57	73.00	-37.43	peak
5	23.1299	26.99	10.30	37.29	73.00	-35.71	peak
6	29.2340	26.41	10.46	36.87	73.00	-36.13	peak

Remark: 1. QP = Quasi Peak, AVG = Average
 2. Correction Factor = Insertion loss of LISN + Cable loss + Transient Limiter (If use)
 3. Measurement Value = Reading Level + Correct Factor
 4. Margin Level = Measurement Value - Limit Value

4.1.7 Photographs of Test Configuration

Mode A

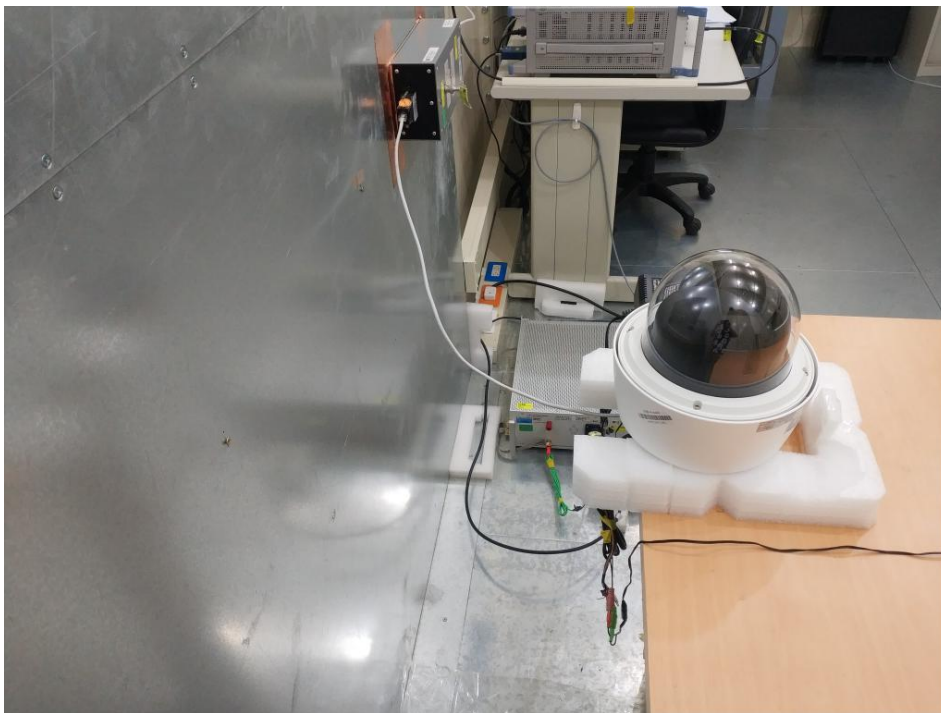

Mode B

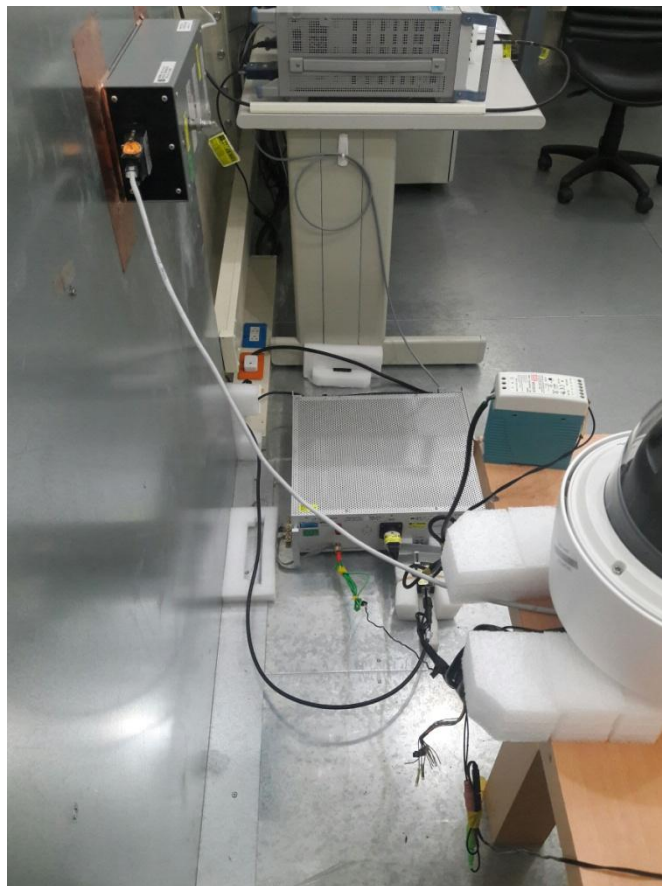



4.2 Radiated Emission Measurement

4.2.1 Limits of Radiated Emission Measurement

Radiated Frequency range 30 MHz to 1000 MHz

Radiated Emissions Limits at 10 meters				
Frequencies (MHz)	FCC 15B/ ICES-003		CISPR 22	
	Class A (dB μ V/m)	Class B (dB μ V/m)	Class A (dB μ V/m)	Class B (dB μ V/m)
30-88	39	29.5	40	30
88-216	43.5	33.1		
216-230	46.4	35.6		
230-960			47	37
960-1000	49.5	43.5		

Radiated Emissions Limits at 3 meters				
Frequencies (MHz)	FCC 15B/ ICES-003		CISPR 22	
	Class A (dB μ V/m)	Class B (dB μ V/m)	Class A (dB μ V/m)	Class B (dB μ V/m)
30-88	49.5	40	50.5	40.5
88-216	54	43.5		
216-230	56.9	46		
230-960			57.5	47.5
960-1000	60	54		

Note: 1. The lower limit shall apply at the transition frequency.

2. Detector function in the form: PK = Peak, QP = Quasi Peak, AV = Average

3. The test result calculated as following:

Measurement Value = Reading Level + Correct Factor

Correction Factor = Antenna factor + Cable loss (Antenna to preamplifier) - preamplifier Gain
+ Cable loss (preamplifier to receiver)

Margin Level = Measurement Value - Limit Value



Radiated Frequency range above 1 GHz

Radiated Emissions Limits at 10 meters						
Frequencies (MHz)	FCC 15B/ ICES-003				CISPR 22	
	Class A (dBµV/m)		Class B (dBµV/m)		Class A (dBµV/m)	Class B (dBµV/m)
	Peak	Average	Peak	Average		
1000-3000	69.5	49.5	63.5	43.5	Not defined	Not defined
Above 3000						

Radiated Emissions Limits at 3meters								
Frequencies (MHz)	FCC 15B/ ICES-003				CISPR 22			
	Class A (dBµV/m)		Class B (dBµV/m)		Class A (dBµV/m)		Class B (dBµV/m)	
	Peak	Average	Peak	Average	Peak	Average	Peak	Average
1000-3000	80	60	74	54	76	56	70	50
Above 3000					80	60	74	54

- Note:**
- The lower limit shall apply at the transition frequency.
 - Detector function in the form: PK = Peak, QP = Quasi Peak, AV = Average
 - The test result calculated as following:
 Measurement Value = Reading Level + Correct Factor
 Correction Factor = Antenna factor + Cable loss (Antenna to preamplifier) - preamplifier Gain + Cable loss (preamplifier to receiver)
 Margin Level = Measurement Value - Limit Value

Frequency Range (For unintentional radiators)

Highest frequency generated or used in the device or on which the device operates or tunes (MHz)	Upper frequency of measurement range (MHz)
Below 1.705	30
1.705-108	1000
108-500	2000
500-1000	5000
Above 1000	5th harmonic of the highest frequency or 40GHz, whichever is lower



4.2.2 Test Instrument

Test Site: W06-966					
Item	Equipment	Manufacturer	Model	Meter No.	Calibration Date
1	Horn Antenna	Schwarzbeck	BBHA 9120D	CT-9-031	Oct. 09, 2018
2	Horn Antenna	Schwarzbeck	BBHA 9170	CT-9-032	Oct. 11, 2018
3	Bilog Antenna	Schwarzbeck	VULB 9168	CT-9-027-2	Oct. 19, 2018
4	EXA Signal Analyzer	Keysight	N9010A	CT-1-093	Apr. 19, 2019
5	EMI Test Receiver	Keysight	N9038A	CT-9-029	Dec. 05, 2018
6	Preamplifier	EMEC	EMC330	CT-9-024	Oct. 16, 2018
7	Preamplifier	EMCI	EMC051845SE	CT-9-012	Oct. 11, 2018
8	Preamplifier	EMCI	EMC184045SE	CT-9-013	Oct. 10, 2018
9	Test Cable	EMEC	EM-CB400	CT-9-001-1	Oct. 18, 2018
10	Test Cable	EMEC	EM-CB400	CT-9-001-2	Oct. 18, 2018
11	Test Cable	EMEC	EM-CB400	CT-9-001-3	Oct. 18, 2018
12	Test Cable	HUBER+SUHNER	SF102	CT-9-002-1	Oct. 10, 2018
13	Test Cable	EMEC	EMC102-KM-KM-600	CT-9-020	Oct. 10, 2018
14	Test Cable	EMEC	EMC102-KM-KM-3000	CT-9-021-1	Oct. 10, 2018
15	Measurement Software	EZ-EMC	Ver : FA-03A2 RE	CT-3-012	No calibration request

Note: 1. The calibration interval of the above test instruments is 12 months.



4.2.3 Test Procedure

- a. The EUT was placed on the top of a turntable 0.8 meters above the ground at a 3 m 966 chamber or 10 m open area test site. The table was rotated 360 degrees to determine the position of the high radiation emissions.
- b. The height of the test antenna shall vary between 1 m to 4 m. Both vertical and horizontal polarizations of the antenna were set to make the measurement.
- c. The EUT was set up as per the test configuration to simulate typical usage per the user's manual. All I/O cables were positioned to simulate typical usage. The actual test configuration, please refer to EUT test photos.
- d. The initial step in collecting radiated emission data is a Spectrum Mode scanning the measurement frequency range.

Below 1GHz:

Reading in which marked as QP or Peak means measurements by using Spectrum Mode with detector RBW=120kHz.

If the Spectrum Mode measured peak value compliance with and lower than Quasi Peak Limit, the EUT shall be deemed to meet QP Limits.

Above 1GHz:

Reading in which marked as Peak & AVG means measurements by using Spectrum Mode with setting in RBW=1MHz.

If the Spectrum Mode measured value compliance with the Peak Limits and lower than AVG Limits, the EUT shall be deemed to meet both Peak and AVG Limits.

- e. Emission frequency and amplitude were recorded, recording at least six highest emissions. The EUT and cable configuration of the above highest emission levels were recorded. The test data of the worst case was recorded.

4.2.4 Deviation from Test Standard

No deviation

4.2.5 Test Setup

< Radiated Emissions Frequency: 30 MHz to 1000 MHz >

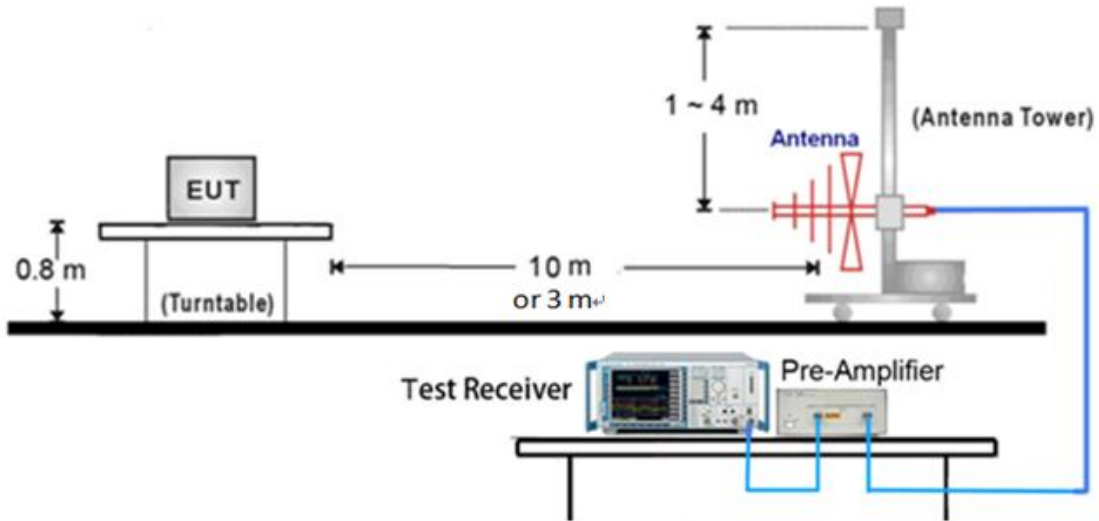

< Radiated Emissions Frequency: above 1GHz >

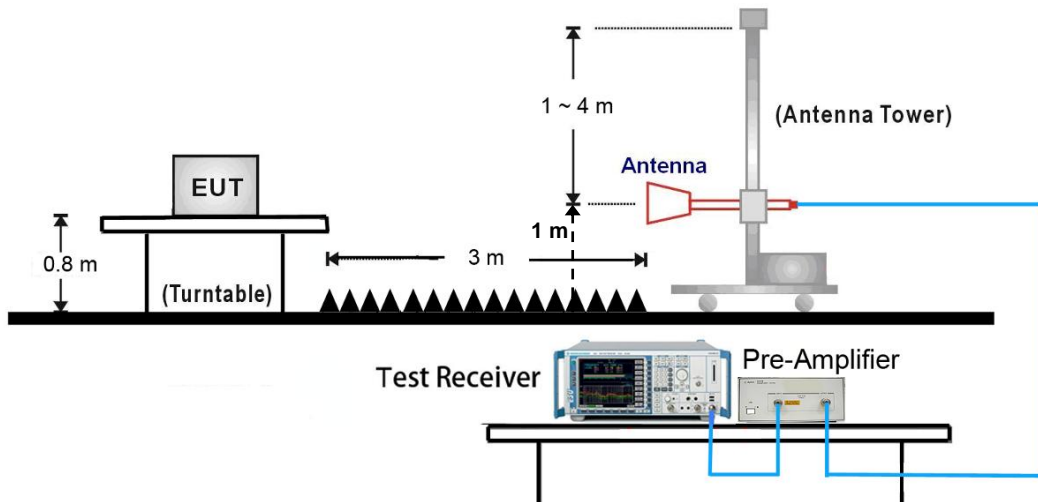

Note:

- (1) Please refer to the 4.2.7 for the actual test configuration.
- (2) The formula of measured value as: $\text{Test Result} = \text{Reading} + \text{Correction Factor}$
- (3) Detector function in the form: PK = Peak, QP = Quasi Peak, AV = Average
- (4) The test result calculated as following:
 $\text{Measurement Value} = \text{Reading Level} + \text{Correct Factor}$
 $\text{Correct Factor} = \text{Antenna Factor} + \text{Cable Loss} - \text{Amplifier Gain (if use)}$
 $\text{Margin Level} = \text{Measurement Value} - \text{Limit Value}$



4.2.6 Test Result

Test Voltage	120Vac, 60Hz	Frequency Range	30 – 1000 MHz
Environmental Conditions	26°C, 69% RH	6dB Bandwidth	120 kHz
Test Date	2019/06/12	Test Distance	3m
Tested by	Karwin Kao	Polarization	Vertical
Test Site	W06	Test Mode	A

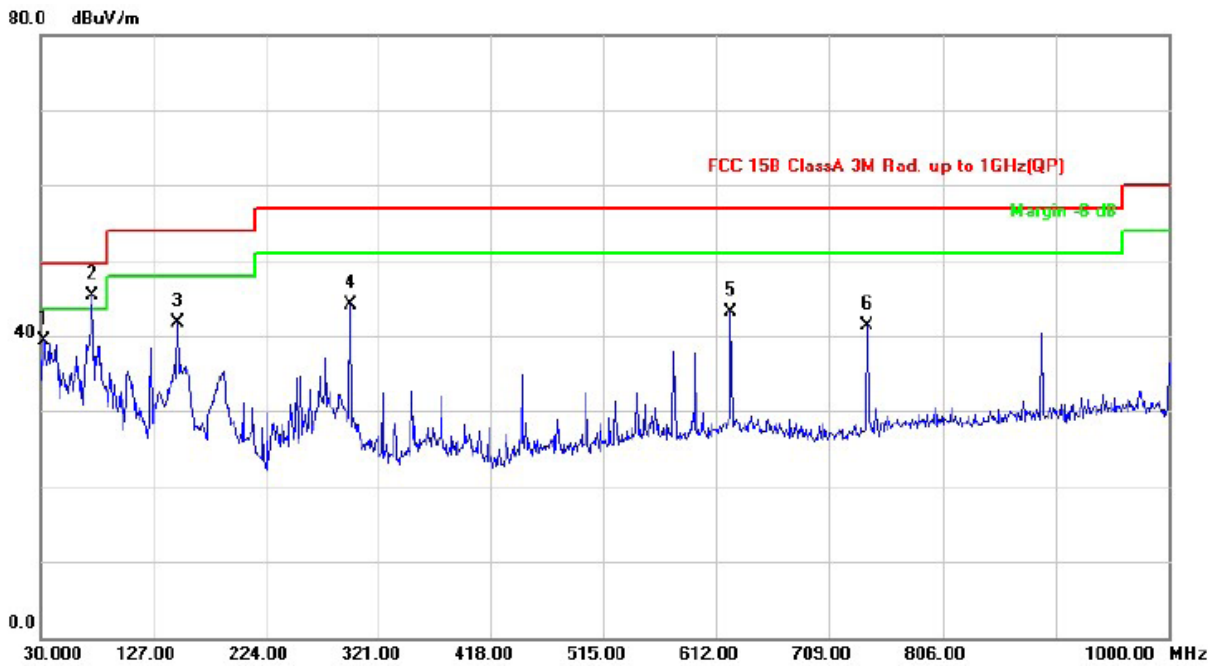

No.	Frequency (MHz)	Reading Level (dBuV)	Correct Factor (dB/m)	Measurement (dBuV/m)	Limit (dBuV/m)	Margin (dB)	Detector	Antenna Height (cm)	Table Degree (degree)
1	32.9099	50.01	-10.64	39.37	49.50	-10.13	peak	100	360
2	74.6200	58.61	-13.22	45.39	49.50	-4.11	peak	100	220
3	148.3400	51.70	-9.90	41.80	54.00	-12.20	peak	100	180
4	296.7500	53.38	-9.20	44.18	56.90	-12.72	peak	138	360
5	624.6100	44.83	-1.68	43.15	56.90	-13.75	peak	100	180
6	741.9800	41.20	0.18	41.38	56.90	-15.52	peak	200	287

Remark: 1. QP = Quasi Peak
 2. Correction Factor = Antenna factor + Cable loss (Antenna to preamplifier) - preamplifier Gain + Cable loss (preamplifier to receiver)
 3. Measurement Value = Reading Level + Correct Factor
 4. Margin Level = Measurement Value - Limit Value



Test Voltage	120Vac, 60Hz	Frequency Range	30 – 1000 MHz
Environmental Conditions	26°C, 69% RH	6dB Bandwidth	120 kHz
Test Date	2019/06/12	Test Distance	3m
Tested by	Karwin Kao	Polarization	Horizontal
Test Site	W06	Test Mode	A

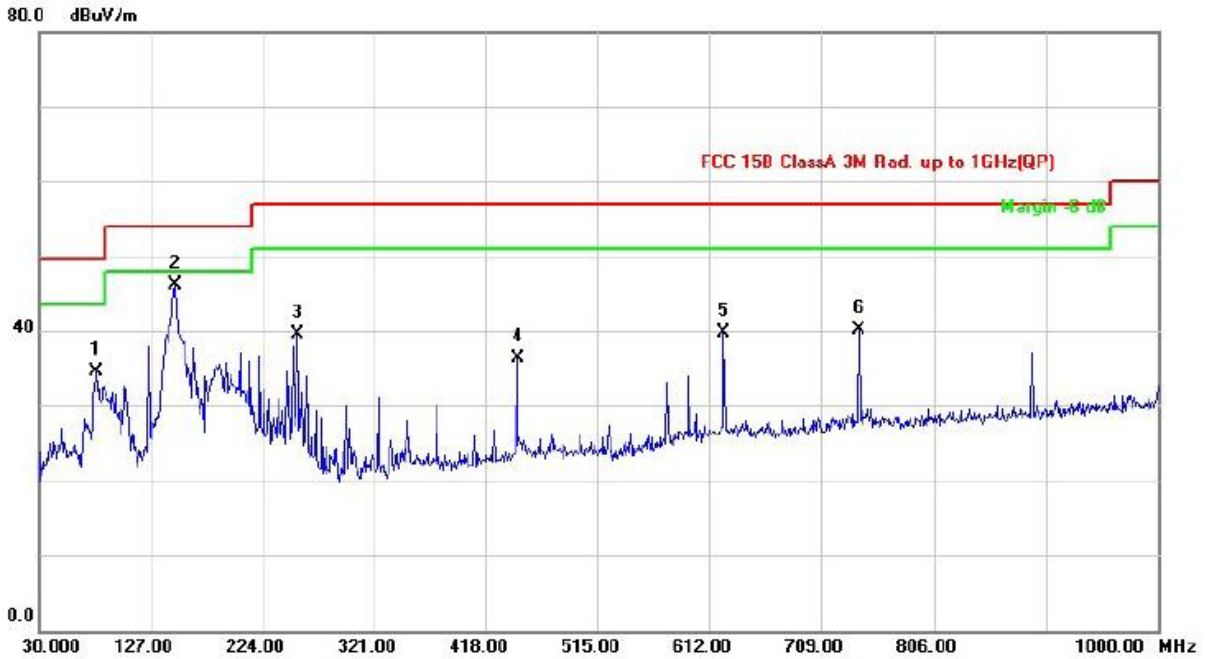

No.	Frequency (MHz)	Reading Level (dBuV)	Correct Factor (dB/m)	Measurement (dBuV/m)	Limit (dBuV/m)	Margin (dB)	Detector	Antenna Height (cm)	Table Degree (degree)
1	79.4700	48.75	-14.33	34.42	49.50	-15.08	peak	200	63
2	148.3400	56.00	-9.90	46.10	54.00	-7.90	peak	200	102
3	254.0700	50.17	-10.67	39.50	56.90	-17.40	peak	100	307
4	445.1600	41.51	-5.29	36.22	56.90	-20.68	peak	112	360
5	624.6100	41.35	-1.68	39.67	56.90	-17.23	peak	200	53
6	741.9800	39.90	0.18	40.08	56.90	-16.82	peak	200	347

Remark: 1. QP = Quasi Peak
 2. Correction Factor = Antenna factor + Cable loss (Antenna to preamplifier) - preamplifier Gain + Cable loss (preamplifier to receiver)
 3. Measurement Value = Reading Level + Correct Factor
 4. Margin Level = Measurement Value - Limit Value



Test Voltage	120Vac, 60Hz	Frequency Range	1 – 10GHz
Environmental Conditions	26°C, 69% RH	6dB Bandwidth	1MHz
Test Date	2019/06/12	Test Distance	3m
Tested by	Karwin Kao	Polarization	Vertical
Test Site	W06	Test Mode	A

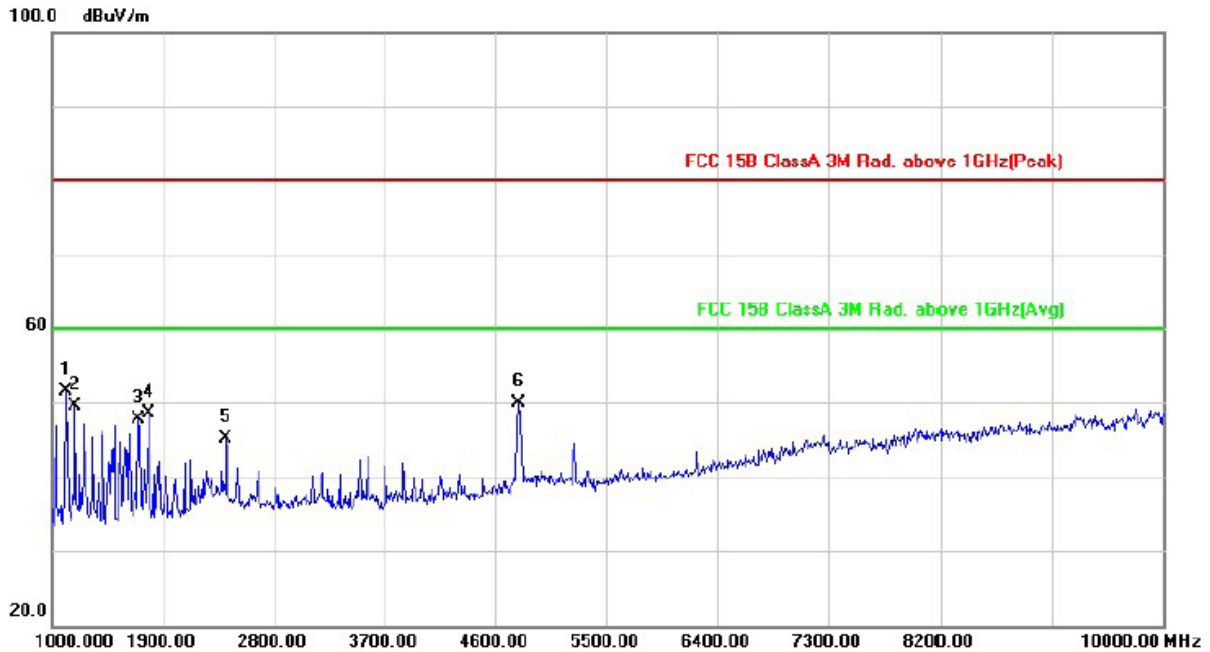

No.	Frequency (MHz)	Reading Level (dBuV)	Correct Factor (dB/m)	Measurement (dBuV/m)	Limit (dBuV/m)	Margin (dB)	Detector	Antenna Height (cm)	Table Degree (degree)
1	1108.000	71.91	-20.35	51.56	80.00	-28.44	peak	100	307
2	1189.000	68.35	-18.82	49.53	80.00	-30.47	peak	100	229
3	1702.000	65.90	-18.23	47.67	80.00	-32.33	peak	175	360
4	1783.000	66.41	-17.88	48.53	80.00	-31.47	peak	175	360
5	2413.000	58.37	-13.29	45.08	80.00	-34.92	peak	200	356
6	4780.000	58.70	-8.70	50.00	80.00	-30.00	peak	200	317

Remark: 1. peak = Peak, AVG = Average
 2. Correction Factor = Antenna factor + Cable loss (Antenna to preamplifier) - preamplifier Gain + Cable loss (preamplifier to receiver)
 3. Measurement Value = Reading Level + Correct Factor
 4. Margin Level = Measurement Value - Limit Value



Test Voltage	120Vac, 60Hz	Frequency Range	1 – 10GHz
Environmental Conditions	26°C, 69% RH	6dB Bandwidth	1MHz
Test Date	2019/06/12	Test Distance	3m
Tested by	Karwin Kao	Polarization	Horizontal
Test Site	W06	Test Mode	A

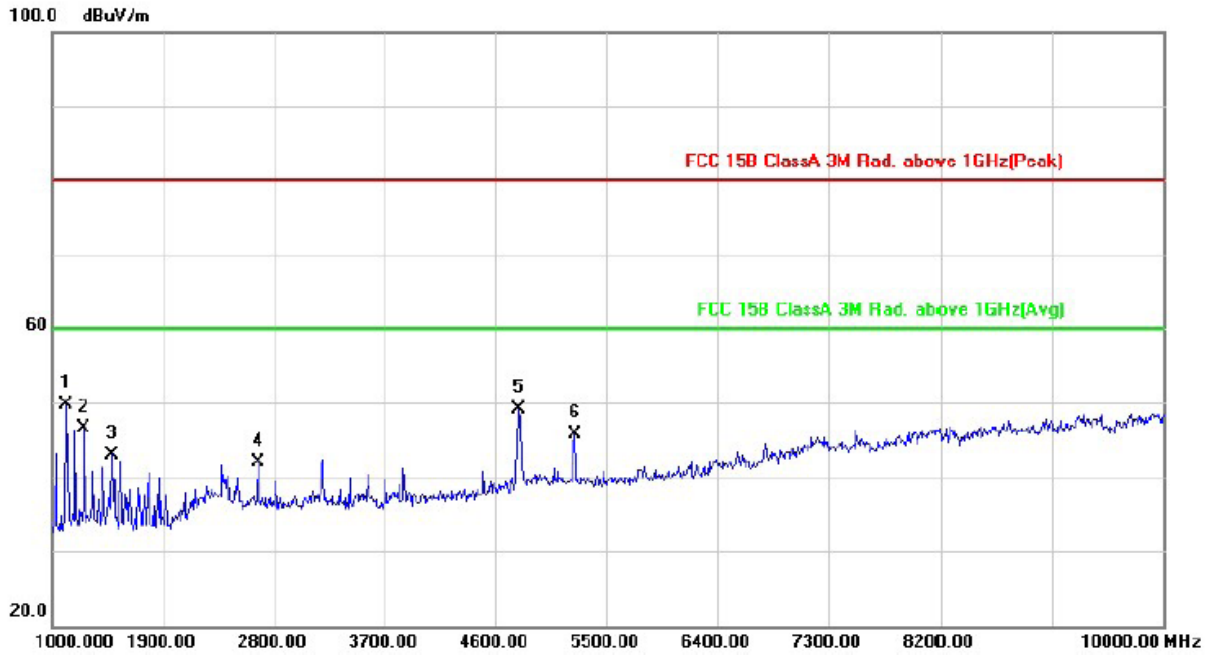

No.	Frequency (MHz)	Reading Level (dBuV)	Correct Factor (dB/m)	Measurement (dBuV/m)	Limit (dBuV/m)	Margin (dB)	Detector	Antenna Height (cm)	Table Degree (degree)
1	1117.000	69.84	-20.23	49.61	80.00	-30.39	peak	200	277
2	1261.000	64.28	-17.75	46.53	80.00	-33.47	peak	200	267
3	1486.000	60.80	-17.96	42.84	80.00	-37.16	peak	200	151
4	2674.000	55.21	-13.40	41.81	80.00	-38.19	peak	200	277
5	4789.000	57.74	-8.69	49.05	80.00	-30.95	peak	200	43
6	5239.000	53.99	-8.27	45.72	80.00	-34.28	peak	200	122

- Remark:**
1. peak = Peak, AVG = Average
 2. Correction Factor = Antenna factor + Cable loss (Antenna to preamplifier) - preamplifier Gain + Cable loss (preamplifier to receiver)
 3. Measurement Value = Reading Level + Correct Factor
 4. Margin Level = Measurement Value - Limit Value



Test Voltage	120Vac, 60Hz	Frequency Range	30 – 1000 MHz
Environmental Conditions	26°C, 69% RH	6dB Bandwidth	120 kHz
Test Date	2019/06/13	Test Distance	3m
Tested by	Karwin Kao	Polarization	Vertical
Test Site	W06	Test Mode	B

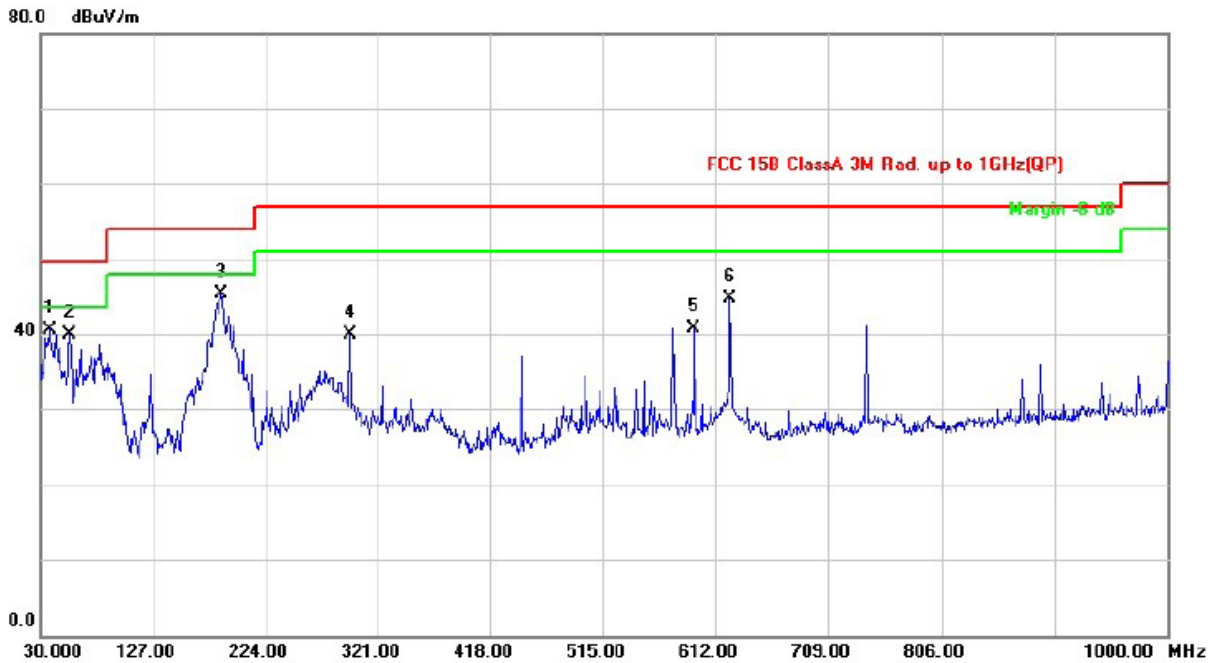

No.	Frequency (MHz)	Reading Level (dBuV)	Correct Factor (dB/m)	Measurement (dBuV/m)	Limit (dBuV/m)	Margin (dB)	Detector	Antenna Height (cm)	Table Degree (degree)
1	37.7599	50.67	-10.07	40.60	49.50	-8.90	peak	101	360
2	55.2199	49.48	-9.66	39.82	49.50	-9.68	peak	100	33
3	185.1999	57.20	-11.80	45.40	54.00	-8.60	peak	100	233
4	296.7500	49.08	-9.20	39.88	56.90	-17.02	peak	200	0
5	593.5700	42.89	-2.11	40.78	56.90	-16.12	peak	200	212
6	624.6100	46.46	-1.68	44.78	56.90	-12.12	peak	100	214

Remark: 1. QP = Quasi Peak
 2. Correction Factor = Antenna factor + Cable loss (Antenna to preamplifier) - preamplifier Gain + Cable loss (preamplifier to receiver)
 3. Measurement Value = Reading Level + Correct Factor
 4. Margin Level = Measurement Value - Limit Value



Test Voltage	120Vac, 60Hz	Frequency Range	30 – 1000 MHz
Environmental Conditions	26°C, 69% RH	6dB Bandwidth	120 kHz
Test Date	2019/06/13	Test Distance	3m
Tested by	Karwin Kao	Polarization	Horizontal
Test Site	W06	Test Mode	B

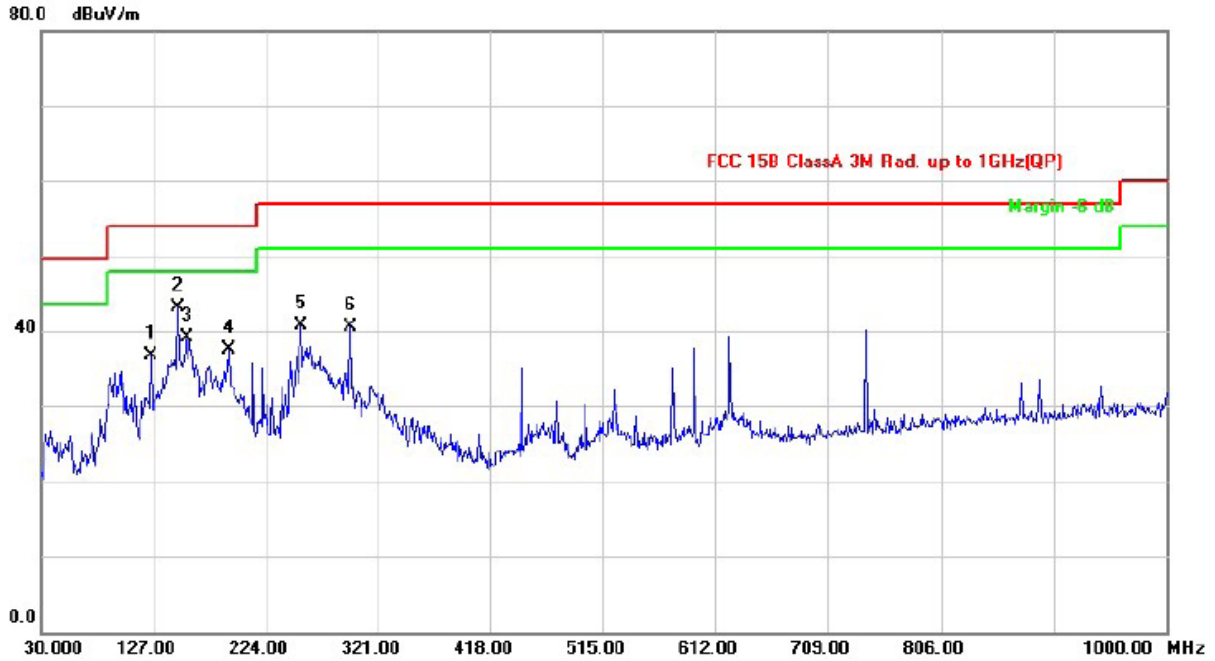

No.	Frequency (MHz)	Reading Level (dBuV)	Correct Factor (dB/m)	Measurement (dBuV/m)	Limit (dBuV/m)	Margin (dB)	Detector	Antenna Height (cm)	Table Degree (degree)
1	125.0600	48.58	-11.91	36.67	54.00	-17.33	peak	200	71
2	148.3400	52.96	-9.90	43.06	54.00	-10.94	peak	200	80
3	156.0999	48.82	-9.80	39.02	54.00	-14.98	peak	200	80
4	191.9900	49.78	-12.36	37.42	54.00	-16.58	peak	200	99
5	254.0699	51.32	-10.67	40.65	56.90	-16.25	peak	100	60
6	296.7500	49.74	-9.20	40.54	56.90	-16.36	peak	100	251

Remark:

1. QP = Quasi Peak
2. Correction Factor = Antenna factor + Cable loss (Antenna to preamplifier) - preamplifier Gain + Cable loss (preamplifier to receiver)
3. Measurement Value = Reading Level + Correct Factor
4. Margin Level = Measurement Value - Limit Value



Test Voltage	120Vac, 60Hz	Frequency Range	1 – 10GHz
Environmental Conditions	26°C, 69% RH	6dB Bandwidth	1MHz
Test Date	2019/06/14	Test Distance	3m
Tested by	Karwin Kao	Polarization	Vertical
Test Site	W06	Test Mode	B

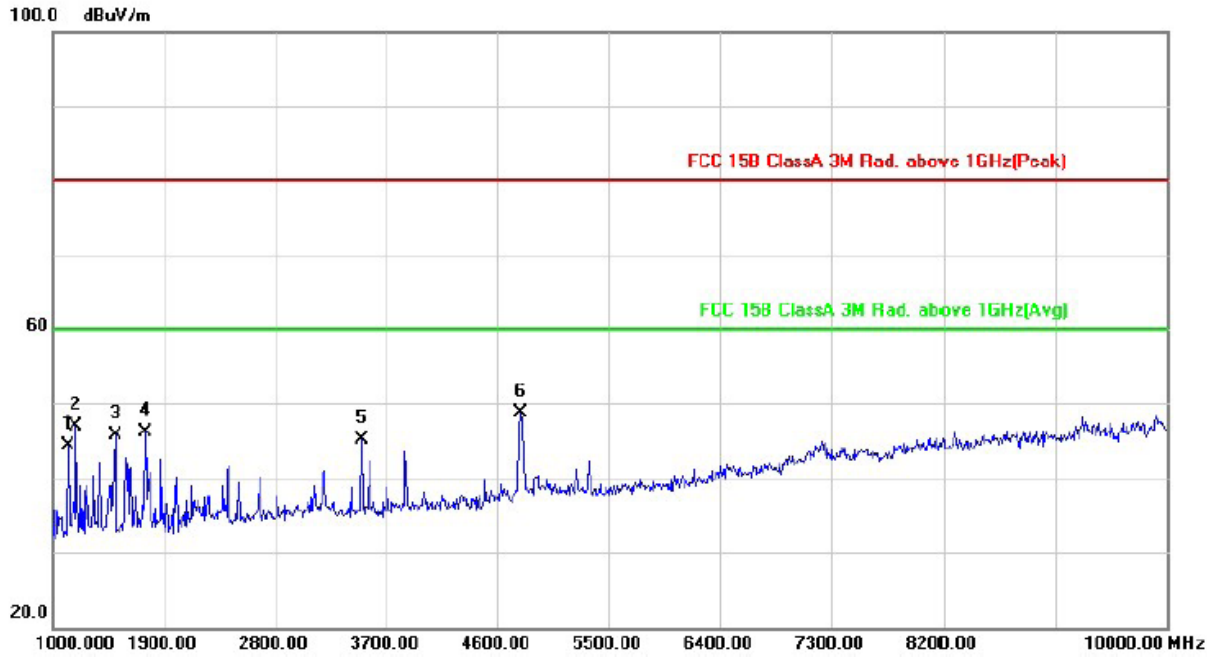

No.	Frequency (MHz)	Reading Level (dBuV)	Correct Factor (dB/m)	Measurement (dBuV/m)	Limit (dBuV/m)	Margin (dB)	Detector	Antenna Height (cm)	Table Degree (degree)
1	1126.000	65.71	-21.51	44.20	80.00	-35.80	peak	200	213
2	1189.000	67.17	-20.22	46.95	80.00	-33.05	peak	101	360
3	1504.000	65.09	-19.45	45.64	80.00	-34.36	peak	200	175
4	1747.000	65.61	-19.48	46.13	80.00	-33.87	peak	200	356
5	3502.000	58.81	-13.64	45.17	80.00	-34.83	peak	200	99
6	4789.000	58.52	-9.83	48.69	80.00	-31.31	peak	200	327

Remark: 1. peak = Peak, AVG = Average
 2. Correction Factor = Antenna factor + Cable loss (Antenna to preamplifier) - preamplifier Gain + Cable loss (preamplifier to receiver)
 3. Measurement Value = Reading Level + Correct Factor
 4. Margin Level = Measurement Value - Limit Value



Test Voltage	120Vac, 60Hz	Frequency Range	1 – 10GHz
Environmental Conditions	26°C, 69% RH	6dB Bandwidth	1MHz
Test Date	2019/06/14	Test Distance	3m
Tested by	Karwin Kao	Polarization	Horizontal
Test Site	W06	Test Mode	B

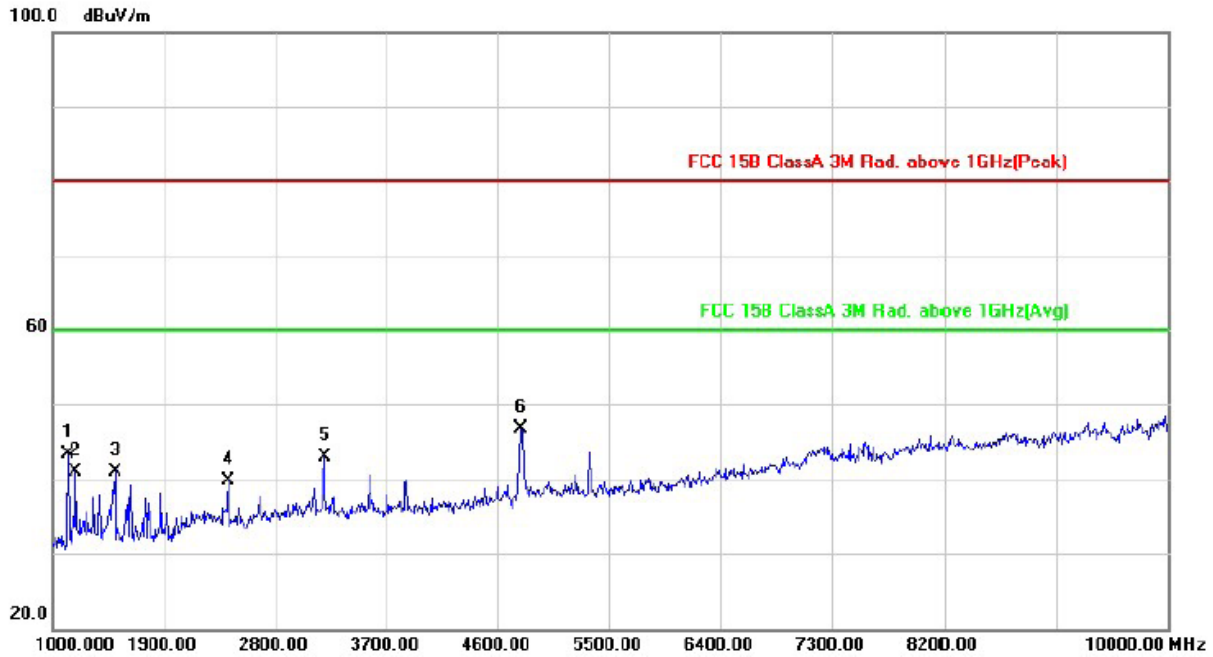

No.	Frequency (MHz)	Reading Level (dBuV)	Correct Factor (dB/m)	Measurement (dBuV/m)	Limit (dBuV/m)	Margin (dB)	Detector	Antenna Height (cm)	Table Degree (degree)
1	1126.000	64.82	-21.51	43.31	80.00	-36.69	peak	200	185
2	1189.000	61.14	-20.22	40.92	80.00	-39.08	peak	200	166
3	1504.000	60.40	-19.45	40.95	80.00	-39.05	peak	100	328
4	2422.000	55.94	-16.21	39.73	80.00	-40.27	peak	200	99
5	3196.000	56.78	-13.95	42.83	80.00	-37.17	peak	100	51
6	4789.000	56.50	-9.83	46.67	80.00	-33.33	peak	100	299

Remark: 1. peak = Peak, AVG = Average
 2. Correction Factor = Antenna factor + Cable loss (Antenna to preamplifier) - preamplifier Gain + Cable loss (preamplifier to receiver)
 3. Measurement Value = Reading Level + Correct Factor
 4. Margin Level = Measurement Value - Limit Value



Test Voltage	55Vdc	Frequency Range	30 – 1000 MHz
Environmental Conditions	26°C, 69% RH	6dB Bandwidth	120 kHz
Test Date	2019/06/12	Test Distance	3m
Tested by	Karwin Kao	Polarization	Vertical
Test Site	W06	Test Mode	C

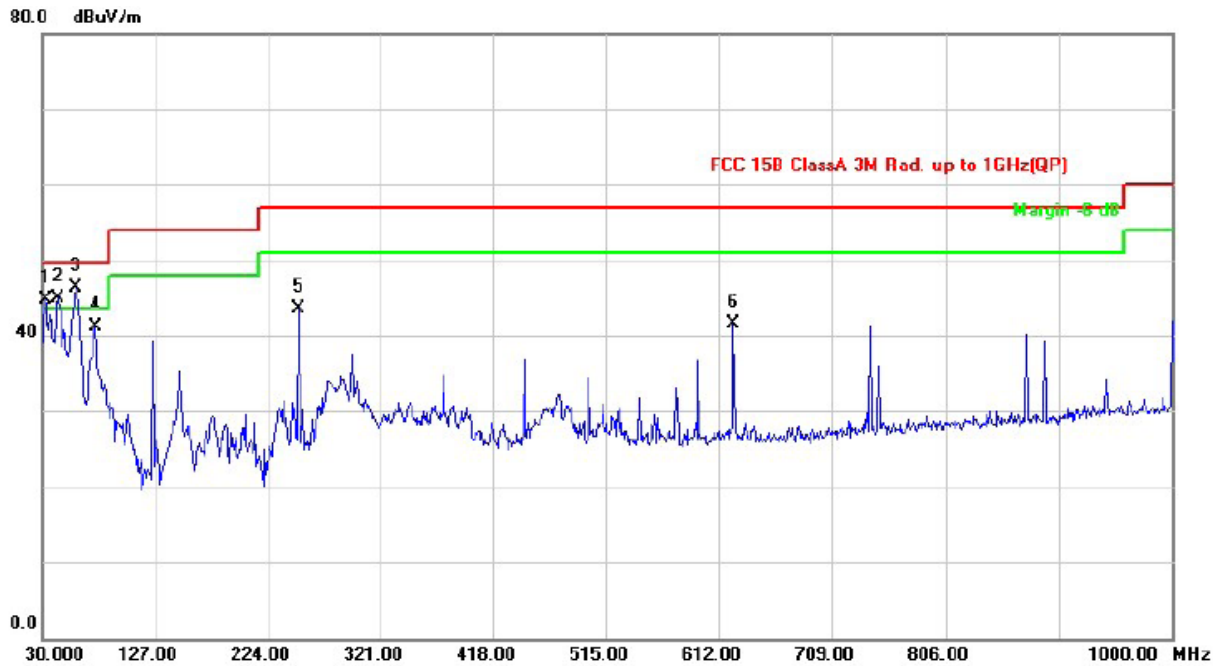

No.	Frequency (MHz)	Reading Level (dBuV)	Correct Factor (dB/m)	Measurement (dBuV/m)	Limit (dBuV/m)	Margin (dB)	Detector	Antenna Height (cm)	Table Degree (degree)
1	32.9099	55.42	-10.64	44.78	49.50	-4.72	peak	100	152
2	43.5799	54.39	-9.49	44.90	49.50	-4.60	peak	100	24
3	59.1000	56.39	-10.14	46.25	49.50	-3.25	peak	100	220
4	75.5899	54.52	-13.42	41.10	49.50	-8.40	peak	100	142
5	250.1899	54.32	-10.75	43.57	56.90	-13.33	peak	200	160
6	624.6100	43.27	-1.68	41.59	56.90	-15.31	peak	100	171

- Remark:**
1. QP = Quasi Peak
 2. Correction Factor = Antenna factor + Cable loss (Antenna to preamplifier) - preamplifier Gain + Cable loss (preamplifier to receiver)
 3. Measurement Value = Reading Level + Correct Factor
 4. Margin Level = Measurement Value - Limit Value



Test Voltage	55Vdc	Frequency Range	30 – 1000 MHz
Environmental Conditions	26°C, 69% RH	6dB Bandwidth	120 kHz
Test Date	2019/06/12	Test Distance	3m
Tested by	Karwin Kao	Polarization	Horizontal
Test Site	W06	Test Mode	C

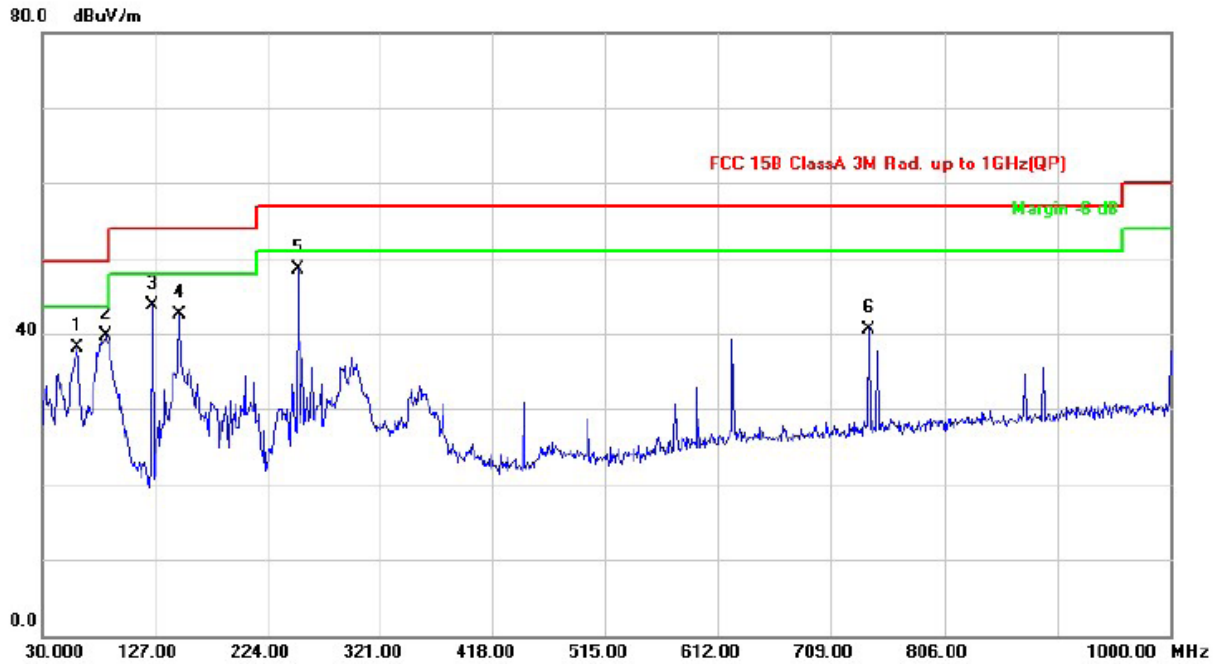

No.	Frequency (MHz)	Reading Level (dBuV)	Correct Factor (dB/m)	Measurement (dBuV/m)	Limit (dBuV/m)	Margin (dB)	Detector	Antenna Height (cm)	Table Degree (degree)
1	60.0700	48.21	-10.15	38.06	49.50	-11.44	peak	100	199
2	84.3200	54.95	-15.33	39.62	49.50	-9.88	peak	200	259
3	125.0600	55.63	-11.91	43.72	54.00	-10.28	peak	200	278
4	148.3400	52.39	-9.90	42.49	54.00	-11.51	peak	200	92
5	250.1900	59.34	-10.75	48.59	56.90	-8.31	peak	100	287
6	741.9800	40.29	0.18	40.47	56.90	-16.43	peak	100	199

Remark:

1. QP = Quasi Peak
2. Correction Factor = Antenna factor + Cable loss (Antenna to preamplifier) - preamplifier Gain + Cable loss (preamplifier to receiver)
3. Measurement Value = Reading Level + Correct Factor
4. Margin Level = Measurement Value - Limit Value



Test Voltage	55Vdc	Frequency Range	1 – 10GHz
Environmental Conditions	26°C, 69% RH	6dB Bandwidth	1MHz
Test Date	2019/06/13	Test Distance	3m
Tested by	Karwin Kao	Polarization	Vertical
Test Site	W06	Test Mode	C

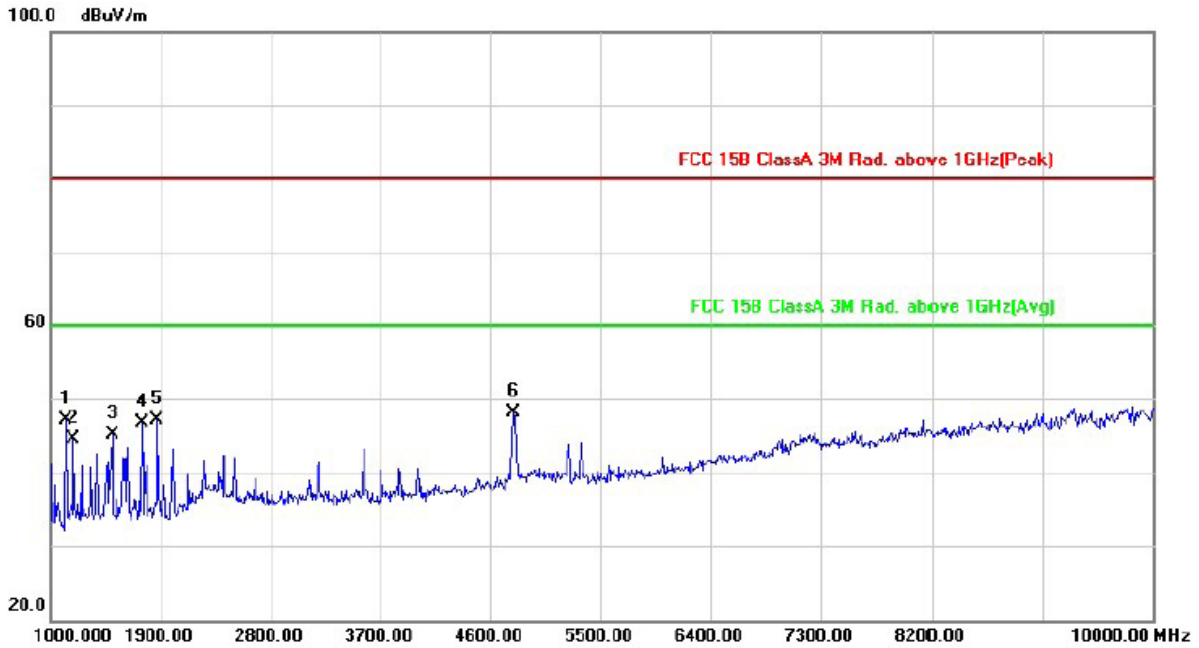

No.	Frequency (MHz)	Reading Level (dBuV)	Correct Factor (dB/m)	Measurement (dBuV/m)	Limit (dBuV/m)	Margin (dB)	Detector	Antenna Height (cm)	Table Degree (degree)
1	1126.000	67.22	-20.11	47.11	80.00	-32.89	peak	100	150
2	1189.000	63.37	-18.82	44.55	80.00	-35.45	peak	100	238
3	1504.000	63.09	-18.05	45.04	80.00	-34.96	peak	200	123
4	1747.000	64.72	-18.08	46.64	80.00	-33.36	peak	200	356
5	1873.000	64.65	-17.52	47.13	80.00	-32.87	peak	200	181
6	4789.000	56.74	-8.69	48.05	80.00	-31.95	peak	200	123

Remark: 1. peak = Peak, AVG = Average
 2. Correction Factor = Antenna factor + Cable loss (Antenna to preamplifier) - preamplifier Gain + Cable loss (preamplifier to receiver)
 3. Measurement Value = Reading Level + Correct Factor
 4. Margin Level = Measurement Value - Limit Value



Test Voltage	55Vdc	Frequency Range	1 – 10GHz
Environmental Conditions	26°C, 69% RH	6dB Bandwidth	1MHz
Test Date	2019/06/13	Test Distance	3m
Tested by	Karwin Kao	Polarization	Horizontal
Test Site	W06	Test Mode	C

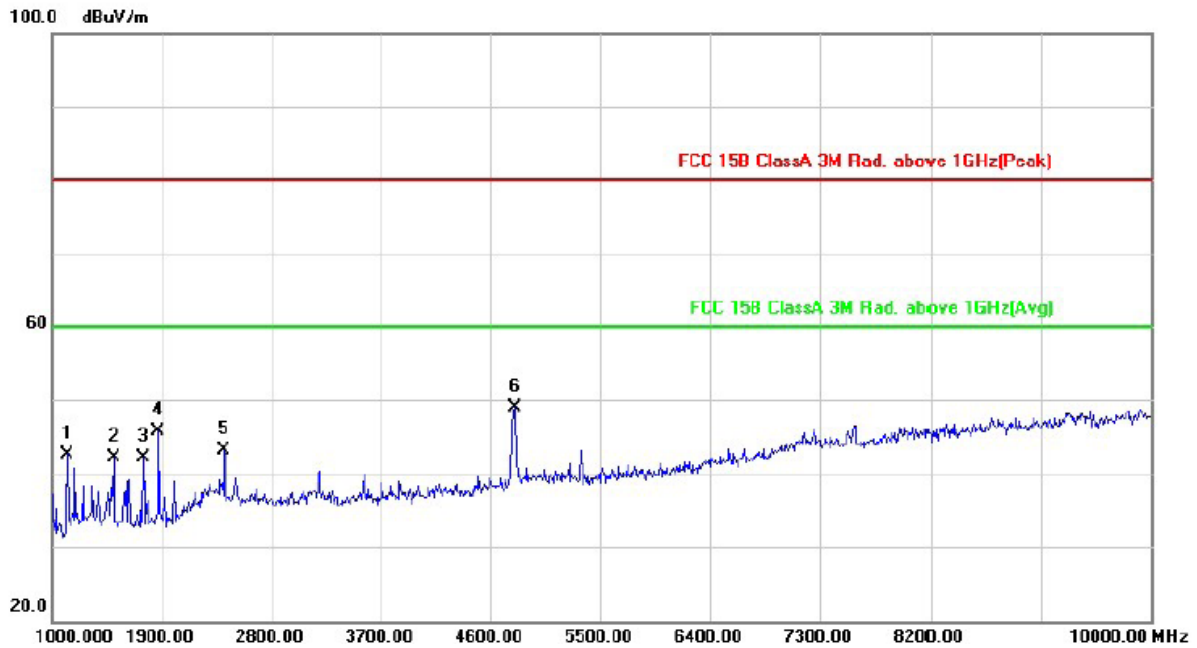

No.	Frequency (MHz)	Reading Level (dBuV)	Correct Factor (dB/m)	Measurement (dBuV/m)	Limit (dBuV/m)	Margin (dB)	Detector	Antenna Height (cm)	Table Degree (degree)
1	1126.000	62.71	-20.11	42.60	80.00	-37.40	peak	200	81
2	1504.000	60.10	-18.05	42.05	80.00	-37.95	peak	100	259
3	1747.000	60.13	-18.08	42.05	80.00	-37.95	peak	200	314
4	1873.000	63.22	-17.52	45.70	80.00	-34.30	peak	100	141
5	2413.000	56.32	-13.29	43.03	80.00	-36.97	peak	100	190
6	4798.000	57.48	-8.67	48.81	80.00	-31.19	peak	100	200

Remark: 1. peak = Peak, AVG = Average
 2. Correction Factor = Antenna factor + Cable loss (Antenna to preamplifier) - preamplifier Gain + Cable loss (preamplifier to receiver)
 3. Measurement Value = Reading Level + Correct Factor
 4. Margin Level = Measurement Value - Limit Value

4.2.7 Photographs of Test Configuration

Radiated Emission Test (30MHz~1GHz) Mode A

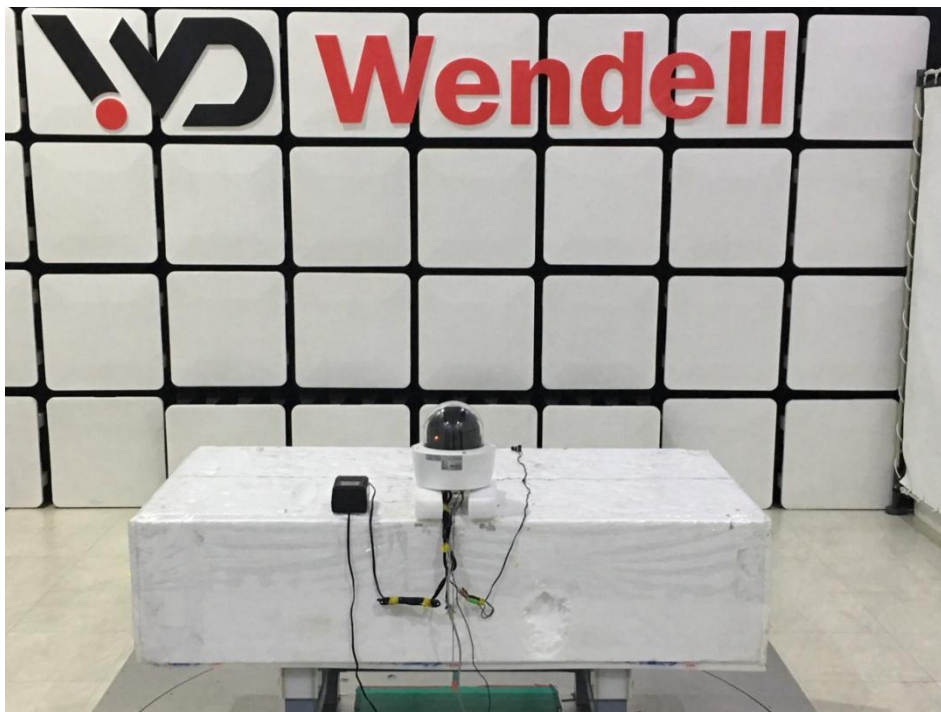

Mode B

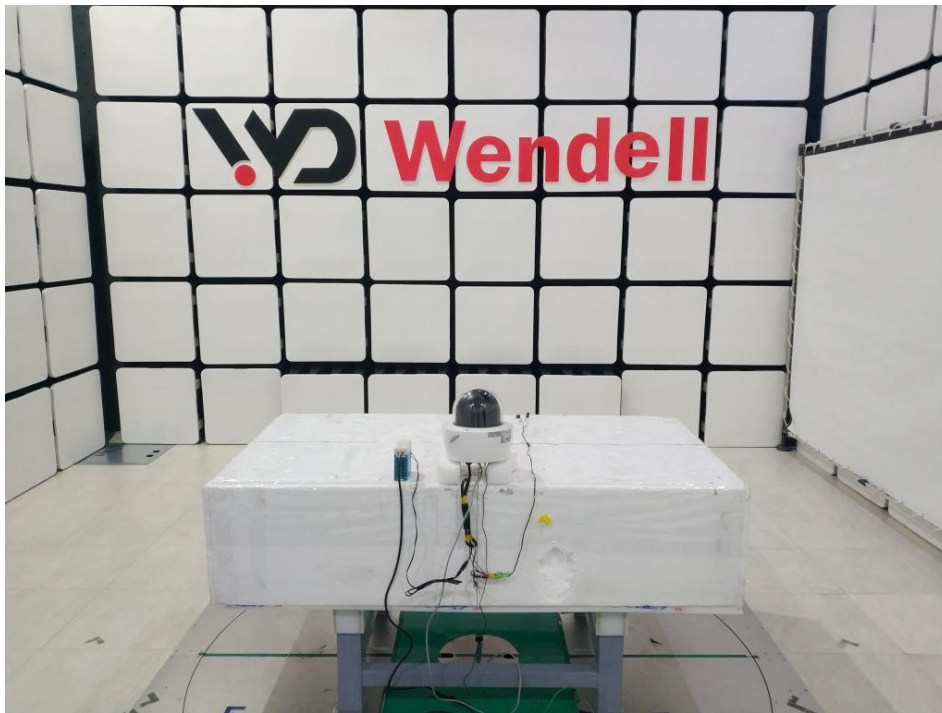

Mode C



Radiated Emission Test (Above 1GHz)
Mode A

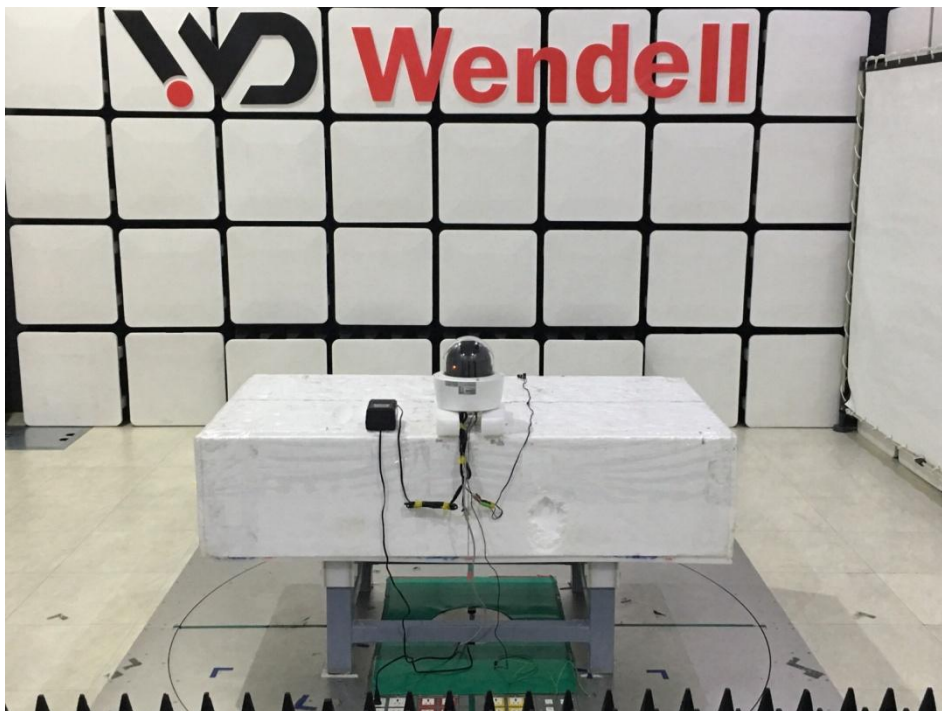
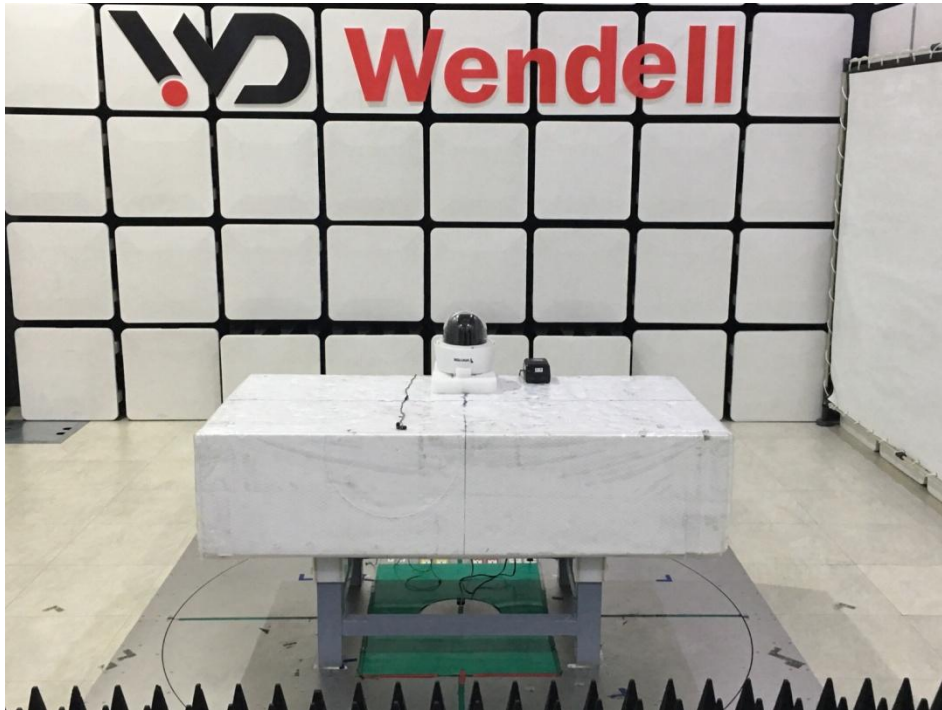

Mode B

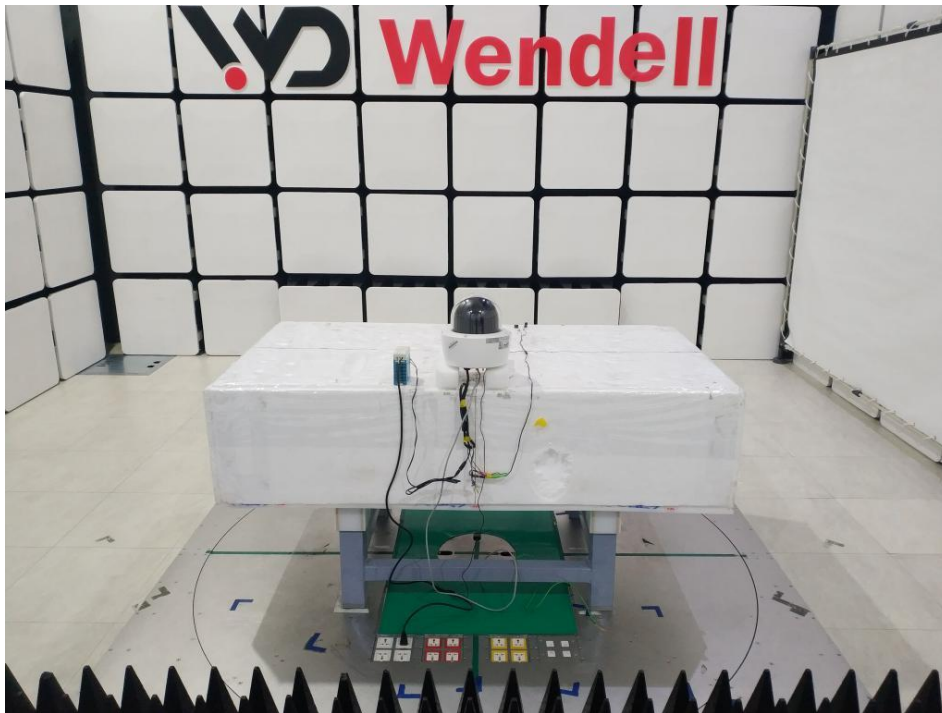
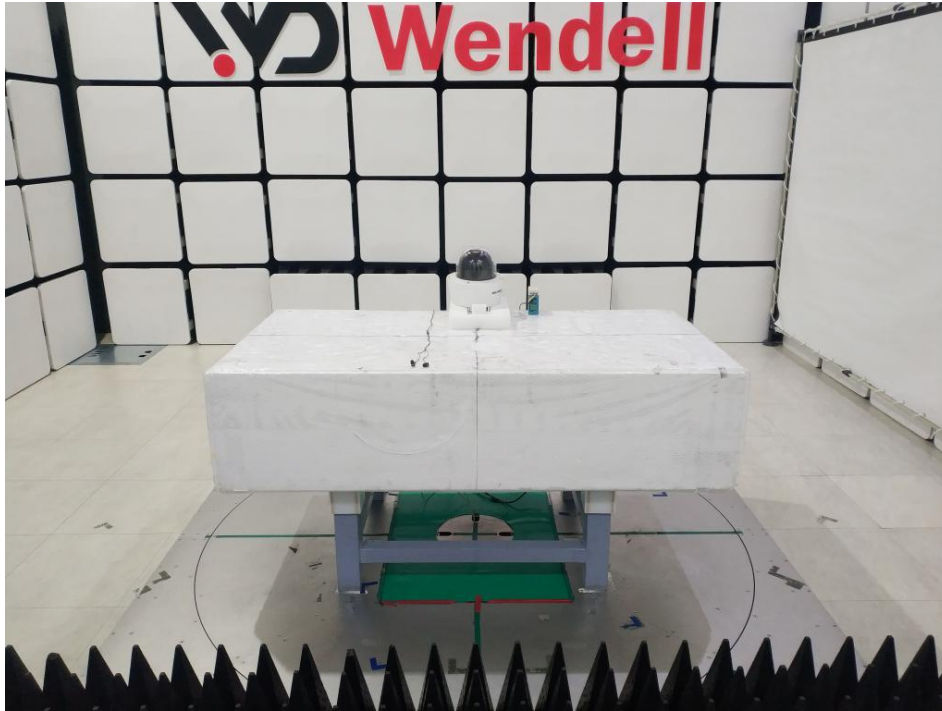

Mode C

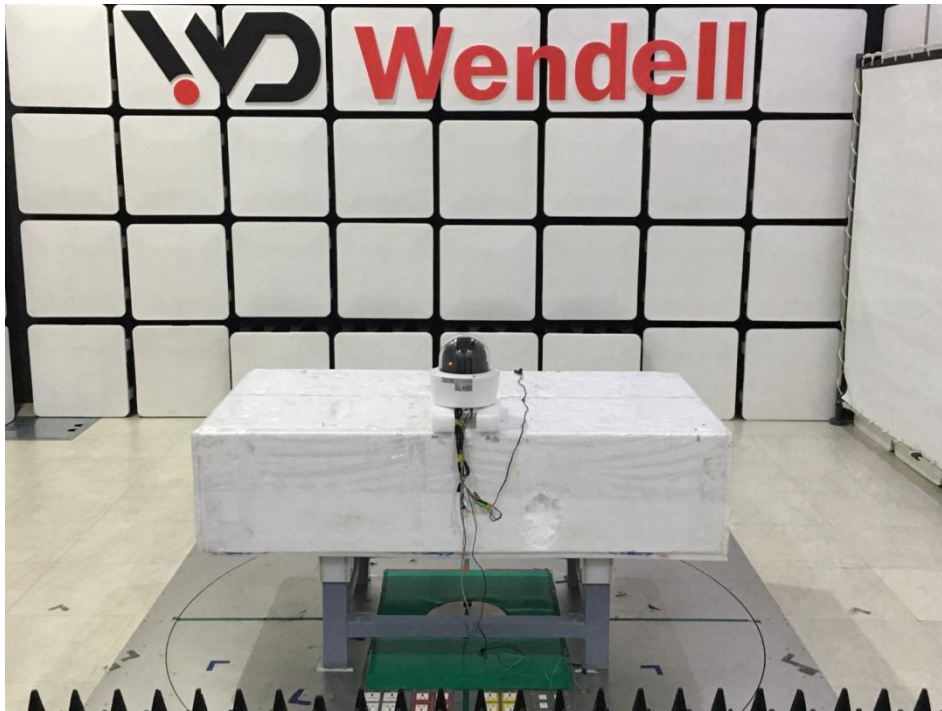
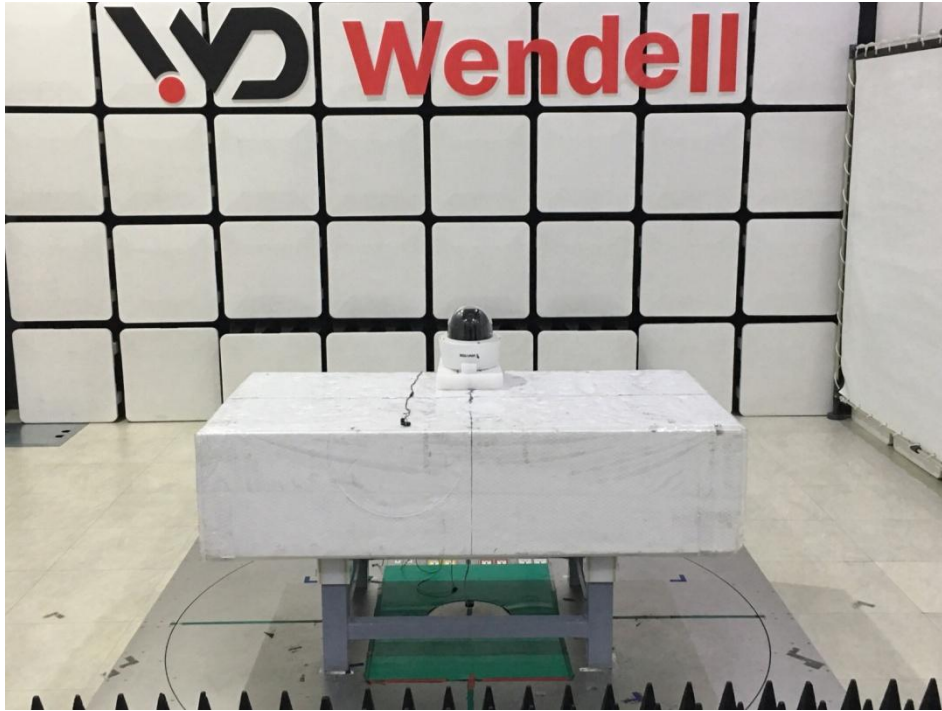

< End Page >