

CE Test Report

Product Name : Network Camera
Model No. : FE9182-H, FE9382-EHV

Applicant : VIVOTEK INC.
Address : 6F, No.192, Lien-Cheng Rd., Chung-Ho , New Taipei City,
235, Taiwan, R.O.C.

Date of Receipt : 2016/08/16
Issued Date : 2016/09/02
Report No. : 1680369R-ITCEP01V00
Report Version : V1.0



The test results relate only to the samples tested.

The test results shown in the test report are traceable to the national/international standard through the calibration of the equipment and evaluated measurement uncertainty herein.

This report must not be used to claim product endorsement by TAF or any agency of the government.

The test report shall not be reproduced without the written approval of QuieTek Corporation.

Test Report

Issued Date : 2016/09/02
Report No. : 1680369R-ITCEP01V00



Product Name : Network Camera
Applicant : VIVOTEK INC.
Address : 6F, No.192, Lien-Cheng Rd., Chung-Ho , New Taipei City, 235,
Taiwan, R.O.C.
Manufacturer : VIVOTEK INC.
Model No. : FE9182-H, FE9382-EHV
EUT Rated Voltage : DC 12V, By PoE
EUT Test Voltage : DC 12V, By PoE
Trade Name : VIVOTEK
Applicable Standard : EN 55022: 2010+AC: 2011, Class B
EN 55032: 2012+AC: 2013
EN 55024: 2010+A1: 2015
CISPR 22: 2008
CISPR 24: 2010
AS/NZS CISPR 22: 2009+A1: 2010
Test Result : Complied
Performed Location : Quietek Corporation (Linkou Laboratory)
No.5-22, Ruishukeng, Linkou Dist., New Taipei City 24451,
Taiwan, R.O.C.
TEL:+866-2-8601-3788 / FAX:+886-2-8601-3789

Documented By : Jessie Ciou
(Adm. Assistant / Jessie Ciou)

Reviewed By : Eddie Tseng
(Engineer / Eddie Tseng)

Approved By : Vincent Lin
(Director / Vincent Lin)

Laboratory Information

We, **Quietek Corporation**, are an independent EMC and safety consultancy that was established the whole facility in our laboratories. The test facility has been accredited/accepted (audited or listed) by the following related bodies in compliance with ISO 17025, EN 45001 and specified testing scopes:

Taiwan R.O.C.	:	BSMI, NCC, TAF
Norway	:	DNV
USA	:	FCC
Japan	:	VCCI

The related certificate for our laboratories about the test site and management system can be downloaded from Quietek Corporation's Web Site : <http://www.quietek.com/chinese/about/certificates.aspx?bval=5>

The address and introduction of Quietek Corporation's laboratories can be founded in our Web site : <http://www.quietek.com/>

If you have any comments, Please don't hesitate to contact us. Our contact information is as below:

HsinChu Testing Laboratory :

No.75-2, 3rd Lin, Wangye Keng, Yonghxing Tsuen, Qionglin Shiang, Hsinchu County 307, Taiwan, R.O.C.

TEL:+886-3-592-8858 / FAX:+886-3-592-8859 E-Mail : service@quietek.com

LinKou Testing Laboratory :

No.5-22, Ruishukeng, Linkou Dist., New Taipei City 24451, Taiwan, R.O.C.

TEL : 886-2-8601-3788 / FAX : 886-2-8601-3789 E-Mail : service@quietek.com

Suzhou (China) Testing Laboratory :

No. 99 Hongye Rd., Suzhou Industrial Park Loufeng Hi-Tech Development Zone., Suzhou,China.

TEL : +86-512-6251-5088 / FAX : +86-512-6251-5098 E-Mail : service@quietek.com

TABLE OF CONTENTS

Description	Page
1. General Information	7
1.1. EUT Description.....	7
1.2. Mode of Operation	7
1.3. Tested System Details	8
1.4. Configuration of Tested System	9
1.5. EUT Exercise Software.....	11
2. Technical Test	12
2.1. Summary of Test Result.....	12
2.2. List of Test Equipment	13
2.3. Measurement Uncertainty.....	15
2.4. Test Environment.....	17
3. Conducted Emission (Main Terminals).....	18
3.1. Test Specification	18
3.2. Test Setup.....	18
3.3. Limit.....	19
3.4. Test Procedure	20
3.5. Deviation from Test Standard.....	20
3.6. Test Result.....	21
3.7. Test Photograph	27
4. Conducted Emissions (Telecommunication Ports).....	29
4.1. Test Specification	29
4.2. Test Setup.....	29
4.3. Limit.....	30
4.4. Test Procedure	31
4.5. Deviation from Test Standard.....	31
4.6. Test Result.....	32
4.7. Test Photograph	44
5. Radiated Emission.....	47
5.1. Test Specification	47
5.2. Test Setup.....	47
5.3. Limit.....	49
5.4. Test Procedure	51
5.5. Deviation from Test Standard.....	51
5.6. Test Result.....	52
5.7. Test Photograph	60

- 6. Electrostatic Discharge 63
 - 6.1. Test Specification 63
 - 6.2. Test Setup..... 63
 - 6.3. Limit..... 63
 - 6.4. Test Procedure 64
 - 6.5. Deviation from Test Standard 64
 - 6.6. Test Result 65
 - 6.7. Test Photograph 67
 - 6.8. EUT to dot photo for ESD test 68
- 7. Radiated Susceptibility 70
 - 7.1. Test Specification 70
 - 7.2. Test Setup..... 70
 - 7.3. Limit..... 70
 - 7.4. Test Procedure 71
 - 7.5. Deviation from Test Standard 71
 - 7.6. Test Result 72
 - 7.7. Test Photograph 74
- 8. Electrical Fast Transient/Burst 80
 - 8.1. Test Specification 80
 - 8.2. Test Setup..... 80
 - 8.3. Limit..... 80
 - 8.4. Test Procedure 81
 - 8.5. Deviation from Test Standard 81
 - 8.6. Test Result 82
 - 8.7. Test Photograph 84
- 9. Surge 86
 - 9.1. Test Specification 86
 - 9.2. Test Setup..... 86
 - 9.3. Limit..... 86
 - 9.4. Test Procedure 87
 - 9.5. Deviation from Test Standard 87
 - 9.6. Test Result 88
 - 9.7. Test Photograph 90
- 10. Conducted Susceptibility 92
 - 10.1. Test Specification 92
 - 10.2. Test Setup..... 92
 - 10.3. Limit..... 93
 - 10.4. Test Procedure 93

- 10.5. Deviation from Test Standard..... 93
- 10.6. Test Result..... 94
- 10.7. Test Photograph 96
- 11. Power Frequency Magnetic Field 98
- 11.1. Test Specification 98
- 11.2. Test Setup..... 98
- 11.3. Limit..... 98
- 11.4. Test Procedure 98
- 11.5. Deviation from Test Standard..... 98
- 11.6. Test Result..... 99
- 11.7. Test Photograph 101
- 12. Attachment 102
- EUT Photograph..... 102

1. General Information

1.1. EUT Description

Product Name	Network Camera
Trade Name	VIVOTEK
Model No.	FE9182-H, FE9382-EHV

1.2. Mode of Operation

Quietek has verified the construction and function in typical operation. All the test modes were carried out with the EUT in normal operation, which was shown in this test report and defined as:

Pre-Test Mode	
Mode 1: FE9382-EHV, DC	
Mode 2: FE9382-EHV, PoE	
Mode 3: FE9182-H, DC	
Mode 4: FE9182-H, PoE	
Final Test Mode	
Emission	Mode 1: FE9382-EHV, DC Mode 2: FE9382-EHV, PoE
Immunity	Mode 1: FE9382-EHV, DC Mode 2: FE9382-EHV, PoE

1.3. Tested System Details

The types for all equipments, plus descriptions of all cables used in the tested system (including inserted cards) are:

Test Mode		Mode 1			
Product		Manufacturer	Model No.	Serial No.	Power Cord
1	Notebook PC	DELL	E5530	24QPXW1	Non-Shielded, 0.8m
2	Microphone & Earphone	Ergotech	E201	N/A	N/A

Test Mode		Mode 2			
Product		Manufacturer	Model No.	Serial No.	Power Cord
1	POE	N/A	N/A	N/A	N/A
2	Notebook PC	DELL	E5530	24QPXW1	Non-Shielded, 0.8m
3	Microphone & Earphone	Ergotech	E201	N/A	N/A

1.4. Configuration of Tested System

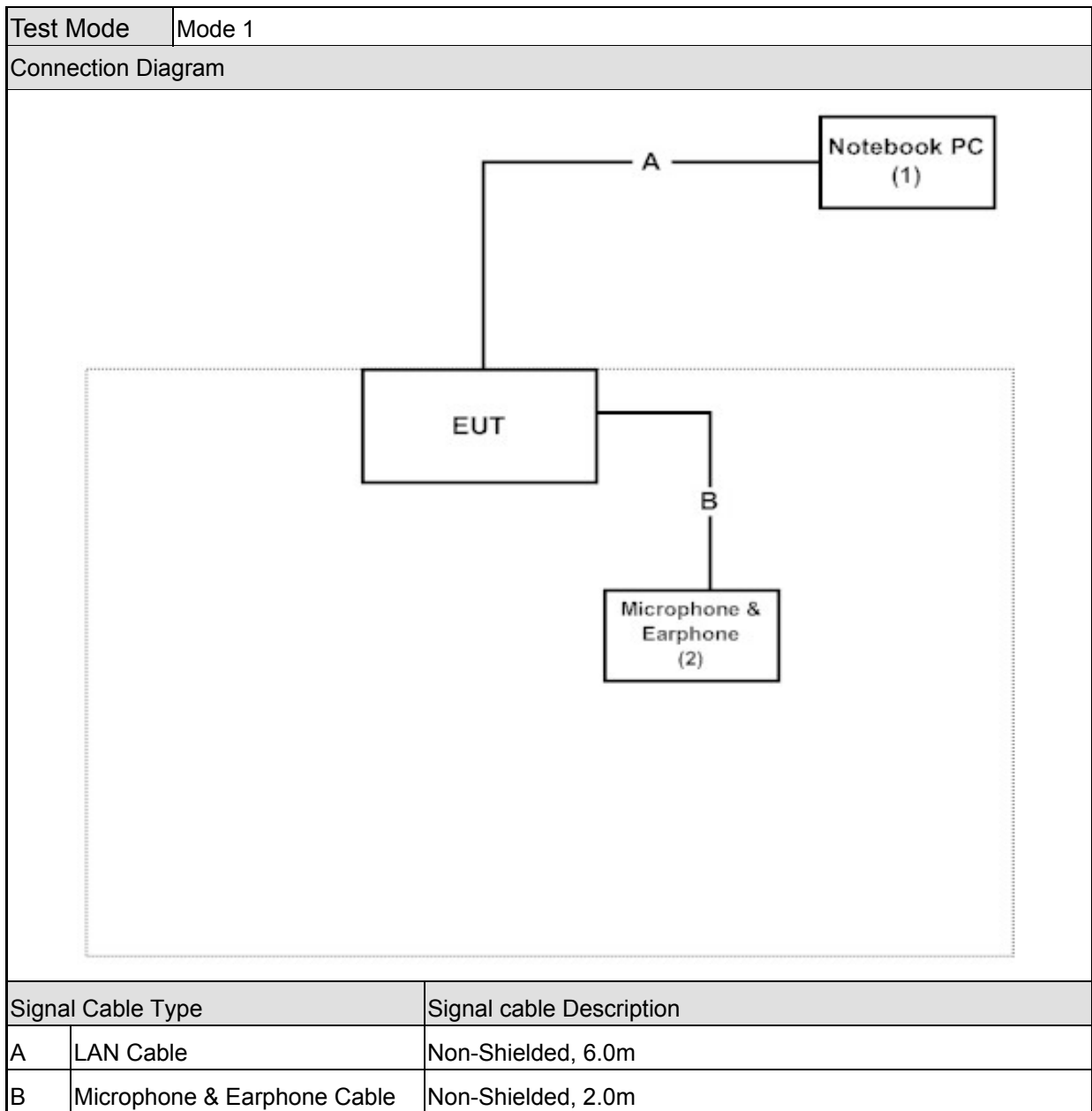

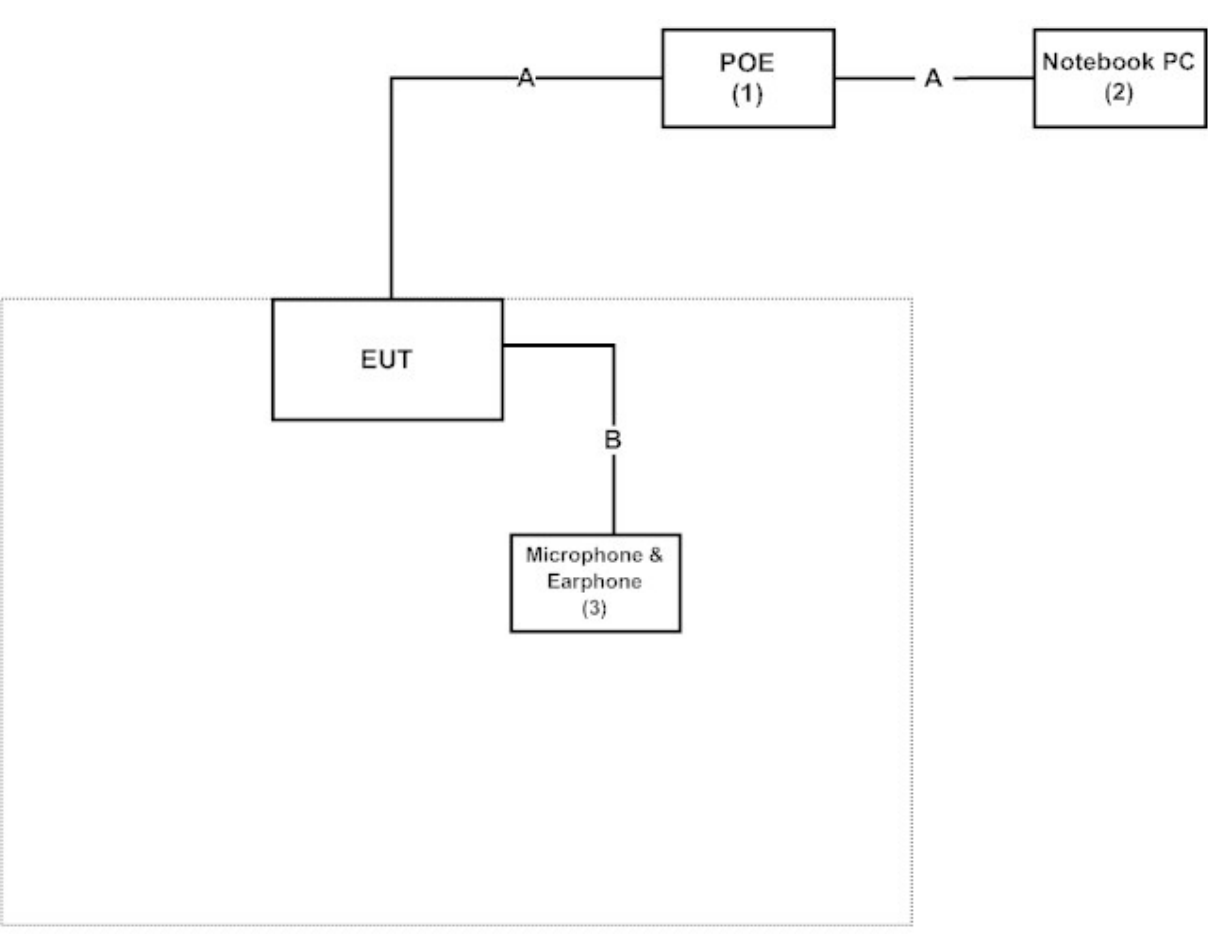
Test Mode	Mode 2	
Connection Diagram		
 <pre> graph TD EUT[EUT] --- A --- POE1[POE (1)] POE1 --- A --- NotebookPC[Notebook PC (2)] EUT --- B --- ME[Microphone & Earphone (3)] </pre>		
Signal Cable Type		Signal cable Description
A	LAN Cable	Non-Shielded, 6.0m, two PCS.
B	Microphone & Earphone Cable	Non-Shielded, 2.0m

1.5. EUT Exercise Software

1	Setup the EUT and simulators as shown on 1.4.
2	Turn on the power of all equipment.
3	The EUT will start to operate and display the video figure from the signal source.
4	The EUT will display “video figure” on monitor.
5	SD card works while the EUT is recording.
6	Repeat the above procedure (3) to (5).

2. Technical Test

2.1. Summary of Test Result

- No deviations from the test standards
 Deviations from the test standards as below description:

Emission			
Performed Item	Normative References	Test Performed	Deviation
Conducted Emission	EN 55022: 2010+AC: 2011 EN 55032: 2012+AC: 2013 AS/NZS CISPR 22: 2009+A1: 2010	Yes	No
Impedance Stabilization Network	EN 55022: 2010+AC: 2011 EN 55032: 2012+AC: 2013 AS/NZS CISPR 22: 2009+A1: 2010	Yes	No
Radiated Emission	EN 55022: 2010+AC: 2011 EN 55032: 2012+AC: 2013 AS/NZS CISPR 22: 2009+A1: 2010	Yes	No
Power Harmonics	EN 61000-3-2: 2014	No	No
Voltage Fluctuation and Flicker	EN 61000-3-3: 2013	No	No

Immunity			
Performed Item	Normative References	Test Performed	Deviation
Electrostatic Discharge	IEC 61000-4-2 Ed. 2.0: 2008	Yes	No
Radiated susceptibility	IEC 61000-4-3 Ed. 3.2: 2010	Yes	No
Electrical fast transient/burst	IEC 61000-4-4 Ed. 3.0: 2012	Yes	No
Surge	IEC 61000-4-5 Ed. 3.0: 2014	Yes	No
Conducted susceptibility	IEC 61000-4-6 Ed. 4.0: 2013	Yes	No
Power frequency magnetic field	IEC 61000-4-8 Ed. 2.0: 2009	Yes	No
Voltage dips and interruption	IEC 61000-4-11 Ed. 2.0: 2004	No	No

2.2. List of Test Equipment

Conducted Emission / SR1

Instrument	Manufacturer	Type No.	Serial No	Cal. Date
EMI Test Receiver	R&S	ESCS 30	100367	2015/12/21
LISN	R&S	ENV216	100085	2016/01/21
LISN	R&S	ESH3-Z5	836679/023	2016/07/12
Coaxial Cable	QTK(Arnist)	RG 400	LC016-RG	2016/06/23

Impedance Stabilization Network / SR1

Instrument	Manufacturer	Type No.	Serial No	Cal. Date
Capacitive Voltage Probe	Schaffner	CVP2200A	18331	2015/10/30
EMI Test Receiver	R&S	ESCS 30	100367	2015/12/21
LISN	R&S	ENV216	100085	2016/01/21
LISN	R&S	ESH3-Z5	836679/023	2016/07/12
RF Current Probe	FCC	F-65 10KHz~1GHz	198	2015/11/03
Coaxial Cable	QTK(Arnist)	RG 400	LC016-RG	2016/06/23
Coupling Decoupling Network	Teseq	CDN ST08A	33998	2016/08/31
Coupling Decoupling Network	Teseq	CDN T800	30303	2016/04/01
BALANCED TELECOM ISN	FCC	FCC-TLISN-T2-02	20316	2016/08/09

Radiated Emission / Site1

Instrument	Manufacturer	Type No.	Serial No	Cal. Date
Bilog Antenna	Schaffner Chase	CBL6112B	2905	2016/06/11
EMI Test Receiver	R&S	ESCS 30	100121	2016/04/23
Coaxial Cable	QTK(Arnist)	RG 214	LC001-RG	2016/06/14
Coaxial signal switch	Arnist	MP59B	6200436229	2016/06/14
Site1 NSA	QTK	N/A	N/A	2016/06/14

Radiated Emission / CB7

Instrument	Manufacturer	Type No.	Serial No	Cal. Date
EMI Test Receiver	R&S	ESU26	100433	2016/09/03
Horn Antenna	SCHWARZBECK	9120D	576	2015/11/25
Pre-Amplifier	COM-POWER	PAM-118	443019	2016/07/19
CB7 VSWR	QTK	N/A	N/A	2016/06/24

Electrostatic Discharge / SR6

Instrument	Manufacturer	Type No.	Serial No	Cal. Date
ESD Simulator System	Noiseken	ESS-B3011	ESS1233479	2016/02/25
ESD GUN	Noiseken	GT-30R	ESS1233499	2016/02/25
Horizontal Coupling Plane(HCP)	QuieTek	HCP AL50	N/A	N/A
Vertical Coupling Plane(VCP)	QuieTek	VCP AL50	N/A	N/A

Radiated susceptibility / CB5

Instrument	Manufacturer	Type No.	Serial No	Cal. Date
Signal Generator	R&S	SMB100A	106404	2016/05/19
Power Meter	R&S	NRVD(P.M)	100219	2016/05/23
Biconilog Antenna	EMCO	3149	00071675	N/A
Power Amplifier	A&R	30S1G3	309453	N/A
Power Amplifier	SCHAFFNER	CBA9413B	4020	N/A
uniform field calibration	QTK	N/A	N/A	2016/05/19

Electrical fast transient/burst / SR6

Instrument	Manufacturer	Type No.	Serial No	Cal. Date
EMS TEST System	TESEQ	NSG 3060	1685	2016/06/29

Surge / SR6

Instrument	Manufacturer	Type No.	Serial No	Cal. Date
EMS TEST System	TESEQ	NSG 3060	1685	2016/06/29

Conducted susceptibility / SR6

Instrument	Manufacturer	Type No.	Serial No	Cal. Date
TESEQ RF-Generator	TESEQ	NSG 4070B-30	37490	2016/01/26

Power frequency magnetic field / SR3

Instrument	Manufacturer	Type No.	Serial No	Cal. Date
AC Power Source (Harmonic)	TESEQ	NSG 1007-5	1530A00015	2016/08/18
Magnetic Loop Coil	Schaffner	INA 702	160	2016/07/28
Magnetic Loop Coil	TESEQ	INA 703	2007	2016/09/02

2.3. Measurement Uncertainty

Conducted Emission

The measurement uncertainty is evaluated as ± 2.26 dB.

Impedance Stabilization Network

The measurement uncertainty is evaluated as ± 2.26 dB.

Radiated Emission

The measurement uncertainty is evaluated as ± 3.19 dB.

Electrostatic Discharge

As what is concluded in the document from Note2 of clause 5.4.6.2 of ISO/IEC 17025, the requirements for measurement uncertainty in ESD testing are deemed to have been satisfied, and the testing is reported in accordance with the relevant ESD standards. The immunity test signal from the ESD system meet the required specifications in IEC 61000-4-2 through the calibration report with the calibrated uncertainty for the waveform of current and timing as being 2.5 % and 6%.

Radiated susceptibility

As what is concluded in the document from Note2 of clause 5.4.6.2 of ISO/IEC 17025, the requirements for measurement uncertainty in RS testing are deemed to have been satisfied, and the testing is reported in accordance with the relevant RS standards. The immunity test signal from the RS system meet the required specifications in IEC 61000-4-3 through the calibration for the uniform field strength and monitoring for the test level with the uncertainty evaluation report for the electrical field strength as being 3.57 dB.

Electrical fast transient/burst

As what is concluded in the document from Note2 of clause 5.4.6.2 of ISO/IEC 17025, the requirements for measurement uncertainty in EFT/Burst testing are deemed to have been satisfied, and the testing is reported in accordance with the relevant EFT/Burst standards. The immunity test signal from the EFT/Burst system meet the required specifications in IEC 61000-4-4 through the calibration report with the calibrated uncertainty for the waveform of voltage and timing as being 8.4 % and 4.7%.

Surge

As what is concluded in the document from Note2 of clause 5.4.6.2 of ISO/IEC 17025, the requirements for measurement uncertainty in Surge testing are deemed to have been satisfied, and the testing is reported in accordance with the relevant Surge standards. The immunity test signal from the Surge system meet the required specifications in IEC 61000-4-5 through the calibration report with the calibrated uncertainty for the waveform of voltage and timing as being 4.1 % and 3.9%.

Conducted susceptibility

As what is concluded in the document from Note2 of clause 5.4.6.2 of ISO/IEC 17025, the requirements for measurement uncertainty in CS testing are deemed to have been satisfied, and the testing is reported in accordance with the relevant CS standards. The immunity test signal from the CS system meet the required specifications in IEC 61000-4-6 through the calibration for unmodulated signal and monitoring for the test level with the uncertainty evaluation report for the injected modulated signal level through CDN and EM Clamp/Direct Injection as being 2.0 dB and 2.61 dB.

Power frequency magnetic field

As what is concluded in the document from Note2 of clause 5.4.6.2 of ISO/IEC 17025, the requirements for measurement uncertainty in PFM testing are deemed to have been satisfied, and the testing is reported in accordance with the relevant PFM standards. The immunity test signal from the PFM system meet the required specifications in IEC 61000-4-8 through the calibration report with the calibrated uncertainty for the Gauss Meter to verify the output level of magnetic field strength as being 1.0 %.

2.4. Test Environment

Performed Item	Items	Required	Actual
Conducted Emission	Temperature (°C)	15-35	26.3
	Humidity (%RH)	25-75	62
	Barometric pressure (mbar)	860-1060	950-1000
Impedance Stabilization Network	Temperature (°C)	15-35	26.3
	Humidity (%RH)	25-75	62
	Barometric pressure (mbar)	860-1060	950-1000
Radiated Emission	Temperature (°C)	15-35	26.3
	Humidity (%RH)	25-75	62
	Barometric pressure (mbar)	860-1060	950-1000
Electrostatic Discharge	Temperature (°C)	15-35	27
	Humidity (%RH)	30-60	56
	Barometric pressure (mbar)	860-1060	950-1000
Radiated susceptibility	Temperature (°C)	15-35	28
	Humidity (%RH)	25-75	54
	Barometric pressure (mbar)	860-1060	950-1000
Electrical fast transient/burst	Temperature (°C)	15-35	27
	Humidity (%RH)	25-75	54
	Barometric pressure (mbar)	860-1060	950-1000
Surge	Temperature (°C)	15-35	27
	Humidity (%RH)	10-75	54
	Barometric pressure (mbar)	860-1060	950-1000
Conducted susceptibility	Temperature (°C)	15-35	27
	Humidity (%RH)	25-75	56
	Barometric pressure (mbar)	860-1060	950-1000
Power frequency magnetic field	Temperature (°C)	15-35	28
	Humidity (%RH)	25-75	54
	Barometric pressure (mbar)	860-1060	950-1000

3. Conducted Emission (Main Terminals)

3.1. Test Specification

According to EMC Standard : EN 55022 and AS/NZS CISPR 22 and EN 55032

3.2. Test Setup

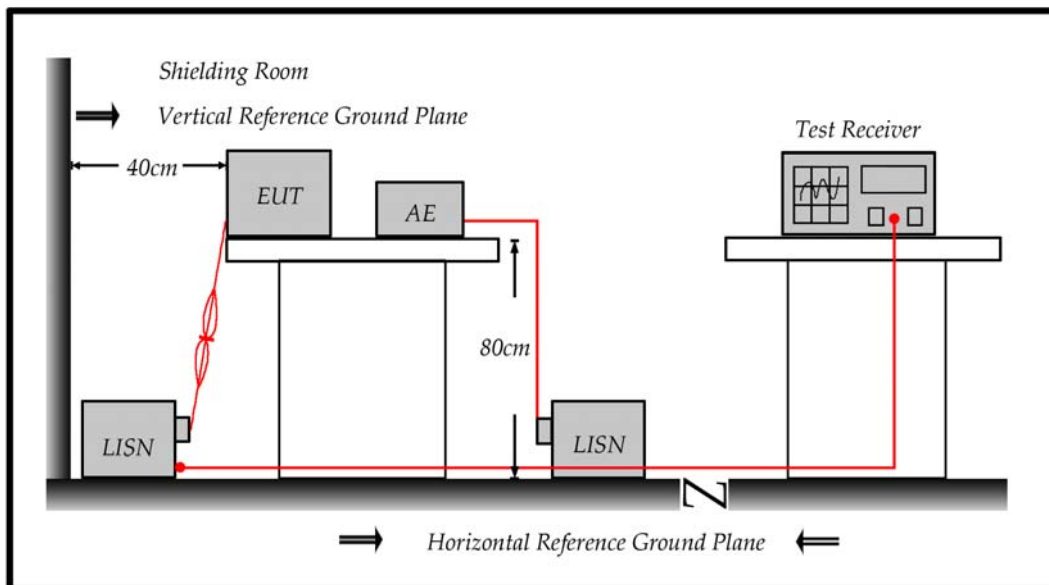
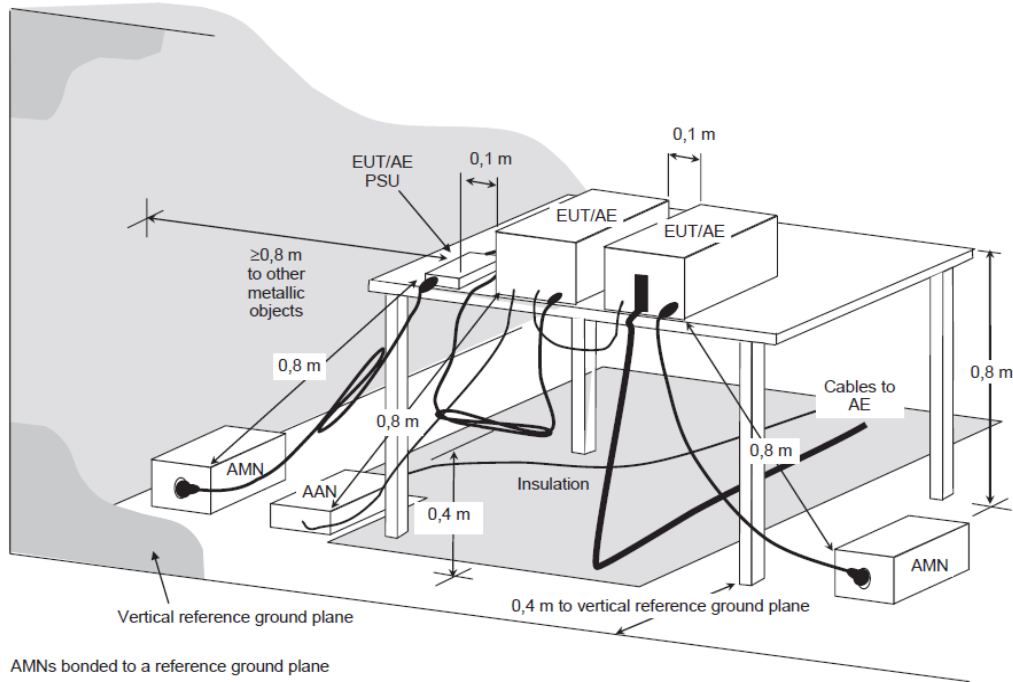

3.3. Limit

Applicable to AC mains power ports			
Frequency range MHz	Coupling device	Detector type/ Bandwidth	Class B limits dB(μV)
0.15 – 0.5	AMN	Quasi Peak / 9 KHz	66 – 56
0.5 – 5			56
Q5 – 30			60
0.15 – 0.5	AMN	Average / 9 KHz	56 – 46
0.5 – 5			46
5 – 30			50

Both apply across the entire frequency range.

Remarks:

If the limits for the average detector are met when using the quasi-peak detector, then the limits for the measurement with the average detector are considered to be met.

Limits		
Frequency (MHz)	QP (dBuV)	AV (dBuV)
0.15 - 0.50	66 - 56	56 – 46
0.50-5.0	56	46
5.0 - 30	60	50

Remarks: In the above table, the tighter limit applies at the band edges.

3.4. Test Procedure

The EUT and simulators are connected to the main power through a line impedance stabilization network (L.I.S.N.). This provides a 50 ohm /50uH coupling impedance for the measuring equipment. The peripheral devices are also connected to the main power through a LISN that provides a 50ohm/50uH coupling impedance with 50ohm termination.

(Please refers to the block diagram of the test setup and photographs.)

Both sides of A.C. line are checked for maximum conducted interference. In order to find the maximum emission, the relative positions of equipment and all of the interface cables must be changed on conducted measurement.

Conducted emissions were invested over the frequency range from 0.15MHz to 30MHz using a receiver bandwidth of 9kHz.

3.5. Deviation from Test Standard

No deviation.

3.6. Test Result

Site : SR1	Time : 2016/08/19 - 16:45
Limit : CISPR_B_00M_QP	Margin : 10
EUT : Network Camera	Probe : ENV216_L1 - Line1
Power : AC 230V/50Hz to DC 12V	Note : Mode 1

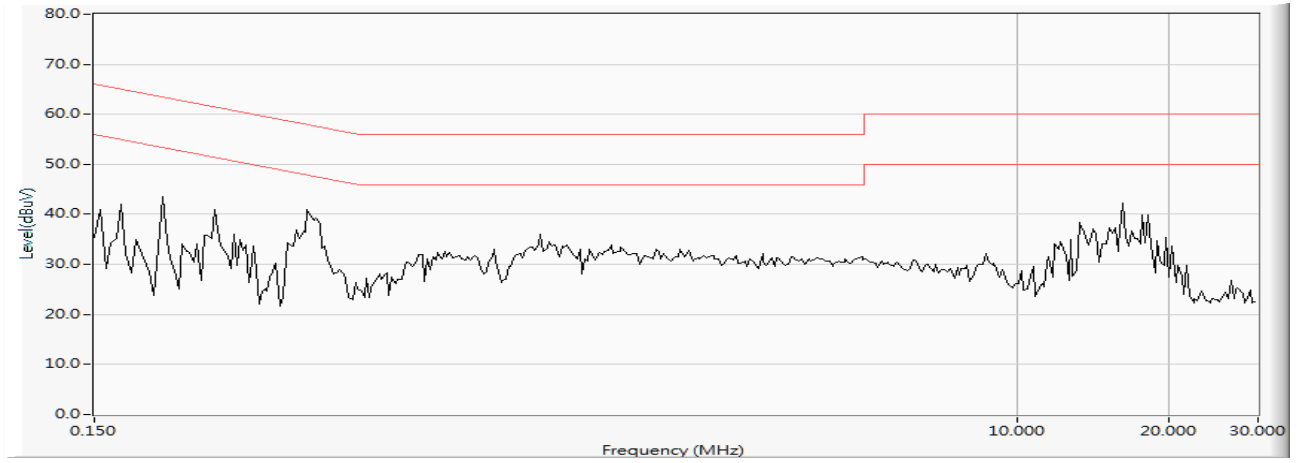

Site : SR1	Time : 2016/08/19 - 16:46
Limit : CISPR_B_00M_QP	Margin : 0
EUT : Network Camera	Probe : ENV216_L1 - Line1
Power : AC 230V/50Hz to DC 12V	Note : Mode 1

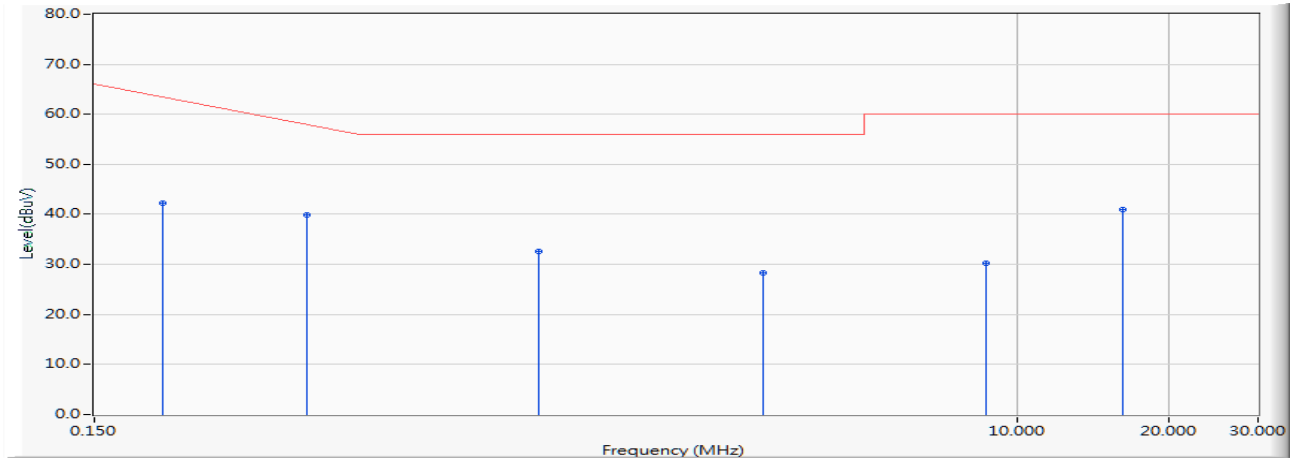

		Frequency (MHz)	Correct Factor (dB)	Reading Level (dBuV)	Measure Level (dBuV)	Margin (dB)	Limit (dBuV)	Detector Type
1		0.205	9.696	32.460	42.156	-22.273	64.429	QUASIPeAK
2		0.396	9.702	30.110	39.812	-19.159	58.971	QUASIPeAK
3		1.138	9.726	22.870	32.596	-23.404	56.000	QUASIPeAK
4		3.146	9.789	18.580	28.369	-27.631	56.000	QUASIPeAK
5		8.716	9.929	20.390	30.319	-29.681	60.000	QUASIPeAK
6	*	16.228	10.071	30.990	41.061	-18.939	60.000	QUASIPeAK

Note:

1. All Reading Levels are Quasi-Peak and average value.
2. " * ", means this data is the worst emission level.
3. Measurement Level = Reading Level + Correct Factor

Site : SR1	Time : 2016/08/19 - 16:46
Limit : CISPR_B_00M_AV	Margin : 0
EUT : Network Camera	Probe : ENV216_L1 - Line1
Power : AC 230V/50Hz to DC 12V	Note : Mode 1

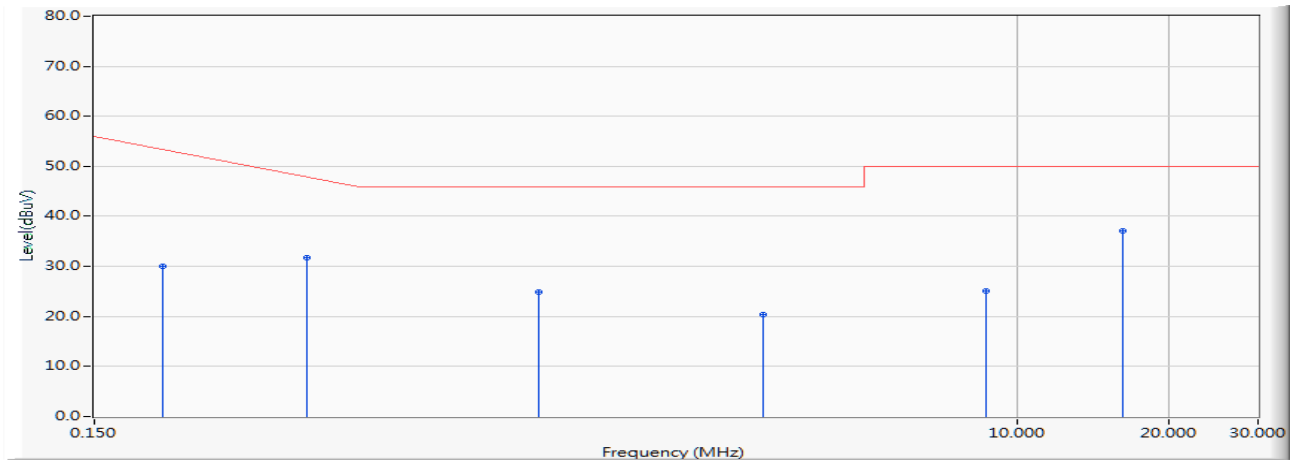

		Frequency (MHz)	Correct Factor (dB)	Reading Level (dBuV)	Measure Level (dBuV)	Margin (dB)	Limit (dBuV)	Detector Type
1		0.205	9.696	20.390	30.086	-24.343	54.429	AVERAGE
2		0.396	9.702	21.970	31.672	-17.299	48.971	AVERAGE
3		1.138	9.726	15.210	24.936	-21.064	46.000	AVERAGE
4		3.146	9.789	10.660	20.449	-25.551	46.000	AVERAGE
5		8.716	9.929	15.240	25.169	-24.831	50.000	AVERAGE
6	*	16.228	10.071	26.970	37.041	-12.959	50.000	AVERAGE

Note:

1. All Reading Levels are Quasi-Peak and average value.
2. " * ", means this data is the worst emission level.
3. Measurement Level = Reading Level + Correct Factor

Site : SR1	Time : 2016/08/19 - 16:52
Limit : CISPR_B_00M_QP	Margin : 10
EUT : Network Camera	Probe : ENV216_N - Line2
Power : AC 230V/50Hz to DC 12V	Note : Mode 1

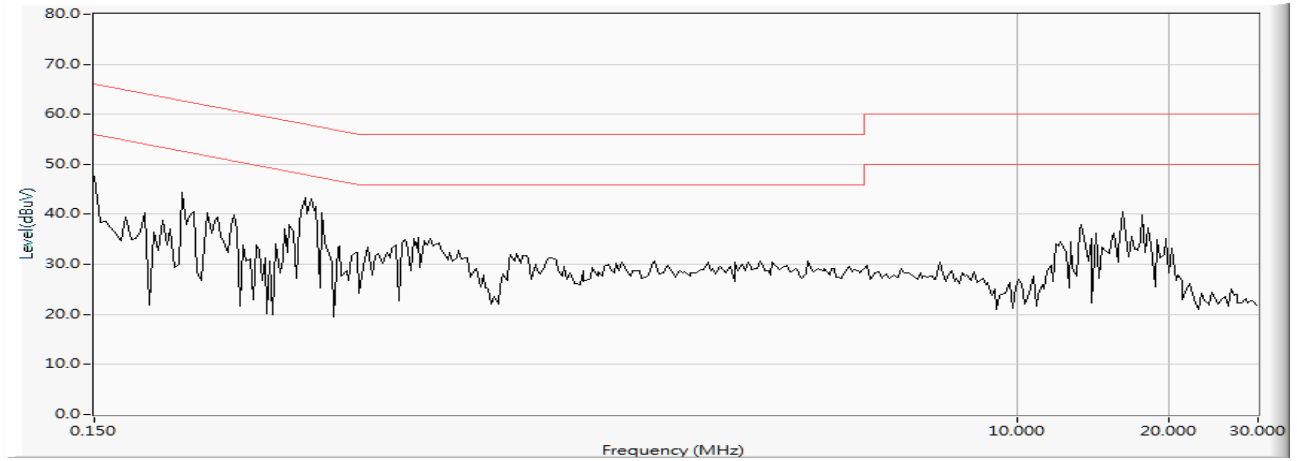

Site : SR1	Time : 2016/08/19 - 16:53
Limit : CISPR_B_00M_QP	Margin : 0
EUT : Network Camera	Probe : ENV216_N - Line2
Power : AC 230V/50Hz to DC 12V	Note : Mode 1

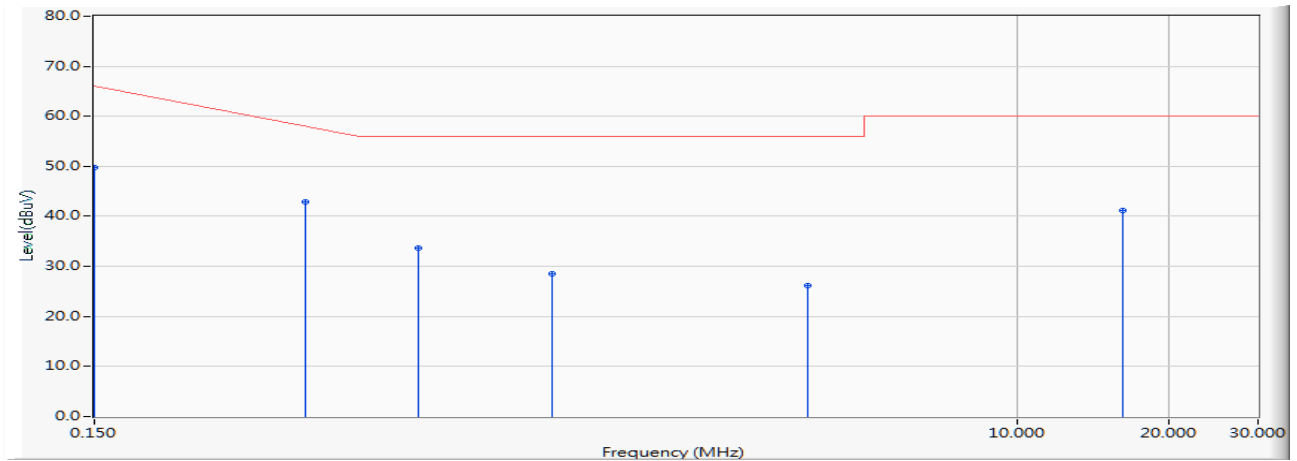

		Frequency (MHz)	Correct Factor (dB)	Reading Level (dBuV)	Measure Level (dBuV)	Margin (dB)	Limit (dBuV)	Detector Type
1		0.150	9.707	39.950	49.657	-16.343	66.000	QUASIPeAK
2	*	0.392	9.692	33.300	42.992	-16.094	59.086	QUASIPeAK
3		0.654	9.701	24.010	33.711	-22.289	56.000	QUASIPeAK
4		1.205	9.718	18.900	28.618	-27.382	56.000	QUASIPeAK
5		3.857	9.795	16.470	26.265	-29.735	56.000	QUASIPeAK
6		16.228	10.171	30.920	41.091	-18.909	60.000	QUASIPeAK

Note:

1. All Reading Levels are Quasi-Peak and average value.
2. " * ", means this data is the worst emission level.
3. Measurement Level = Reading Level + Correct Factor

Site : SR1	Time : 2016/08/19 - 16:53
Limit : CISPR_B_00M_AV	Margin : 0
EUT : Network Camera	Probe : ENV216_N - Line2
Power : AC 230V/50Hz to DC 12V	Note : Mode 1

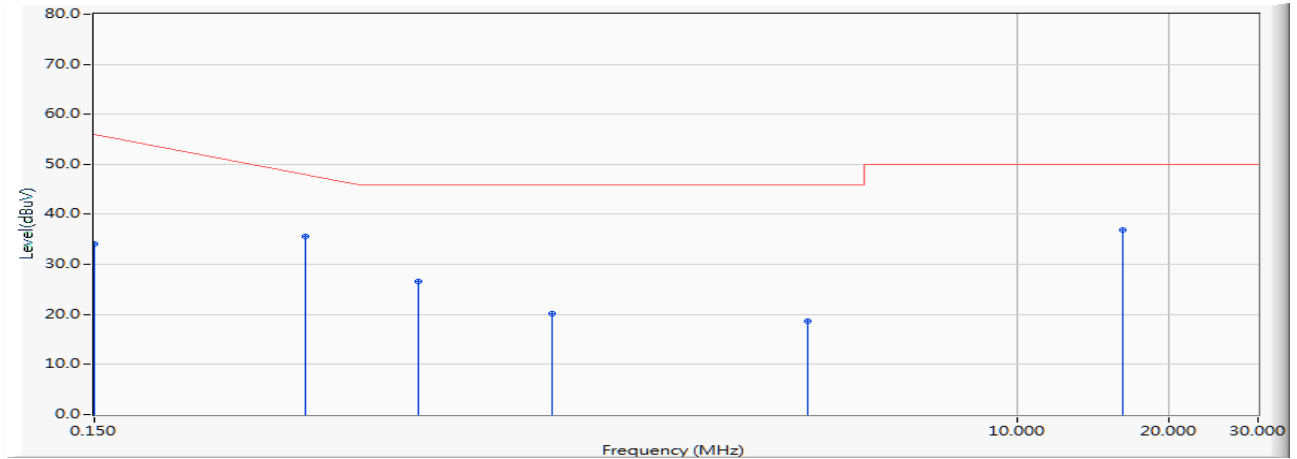

		Frequency (MHz)	Correct Factor (dB)	Reading Level (dBuV)	Measure Level (dBuV)	Margin (dB)	Limit (dBuV)	Detector Type
1		0.150	9.707	24.420	34.127	-21.873	56.000	AVERAGE
2		0.392	9.692	25.910	35.602	-13.484	49.086	AVERAGE
3		0.654	9.701	17.000	26.701	-19.299	46.000	AVERAGE
4		1.205	9.718	10.460	20.178	-25.822	46.000	AVERAGE
5		3.857	9.795	8.820	18.615	-27.385	46.000	AVERAGE
6	*	16.228	10.171	26.790	36.961	-13.039	50.000	AVERAGE

Note:

1. All Reading Levels are Quasi-Peak and average value.
2. " * ", means this data is the worst emission level.
3. Measurement Level = Reading Level + Correct Factor

3.7. Test Photograph

Test Mode : Mode 1: FE9382-EHV, DC

Description : Front View of Conducted Test



Test Mode : Mode 1: FE9382-EHV, DC

Description : Back View of Conducted Test



Test Mode : Mode 1: FE9382-EHV, DC

Description : Back View of Conducted Test



4. Conducted Emissions (Telecommunication Ports)

4.1. Test Specification

According to EMC Standard : EN 55022 and AS/NZS CISPR 22 and EN 55032

4.2. Test Setup

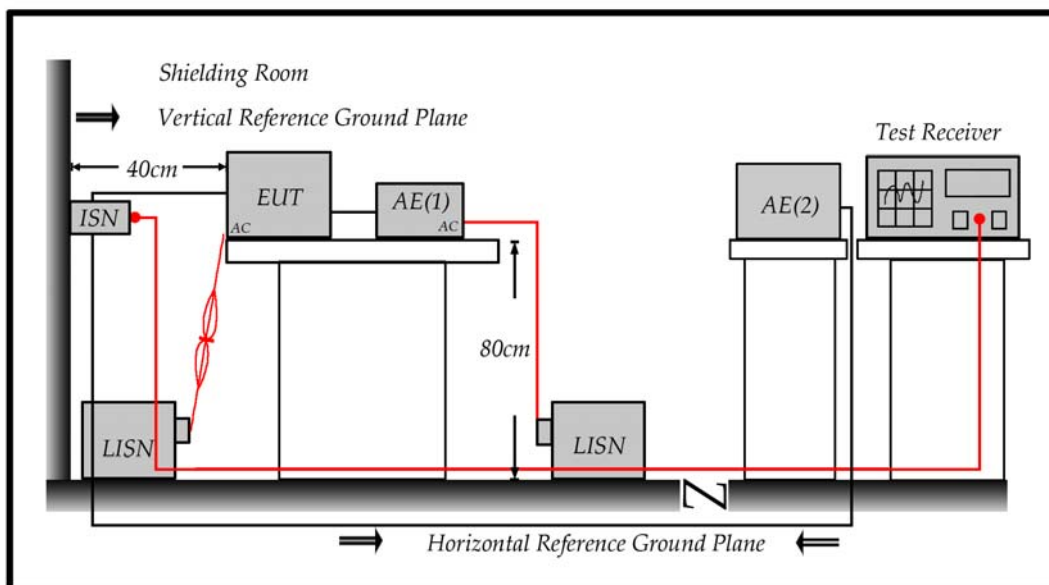
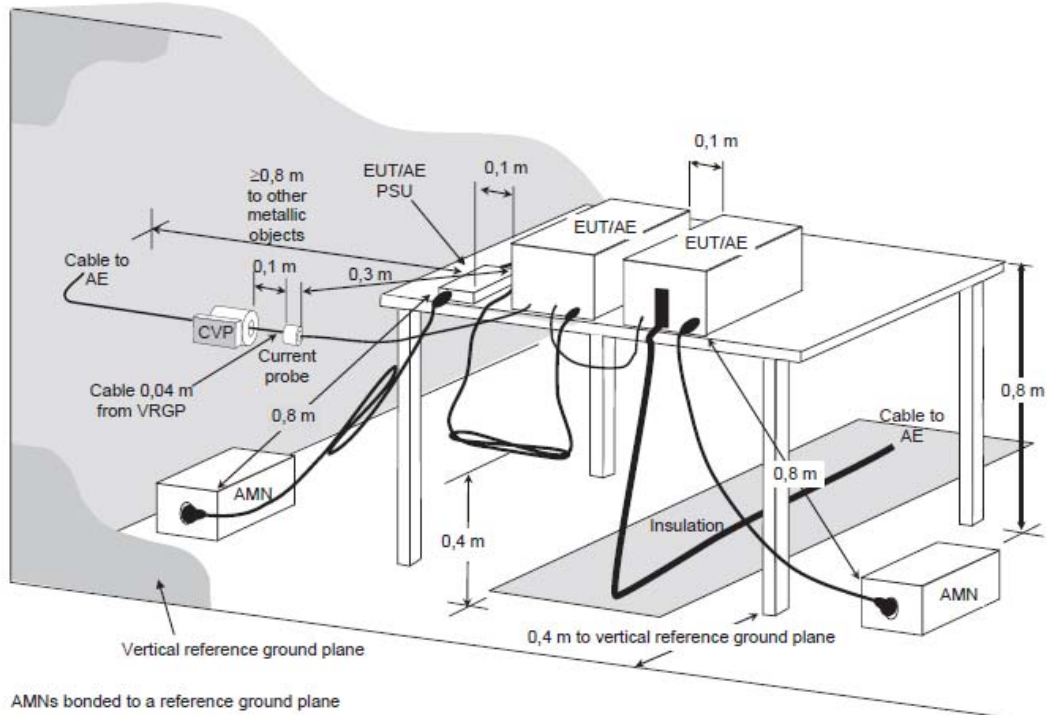

4.3. Limit

Applicable to					
1. wired network ports					
2. optical fibre port with metallic shield or tension members					
3. antenna ports					
Frequency range MHz	Coupling device	Detector type/ Bandwidth	Class B voltage limits dB(μ V)	Class B current limits dB(μ A)	
0.15 – 0.5	AAN	Quasi Peak / 9 KHz	84 – 74	N / A	
0.5 – 30			74		
0.15 – 0.5	AAN	Average / 9 KHz	74 – 64		
0.5 – 30			64		
0.15 – 0.5	CVP	Quasi Peak / 9 KHz	84 – 74		40 – 30
0.5 – 30	And current probe		74		30
0.15 – 0.5	CVP	Average / 9 KHz	74 – 64	30 – 20	
0.5 – 30			And current probe	64	20
0.15 – 0.5	Current Probe	Quasi Peak / 9 KHz	N / A	40 – 30	
0.5 – 30				30	
0.15 – 0.5	Current Probe	Average / 9 KHz		30 – 20	
0.5 – 30				20	

The choice of coupling device and measurement procedure is defined in EN55032:2012 Annex C.

Screened ports including TV broadcast receiver tuner ports are tested with a common-mode impedance of 150 Ω . This is typically accomplished with the screen terminated by 150 Ω to earth.

AC mains ports that also have the function of a wired network port shall meet the limits given in EN55032:2012+AC 2013 Table A.9.

The test shall cover the entire frequency range.

The application of the voltage and/or current limits is dependent on the measurement procedure used. Refer to EN55032:2012+AC 2013 Table C.1 for applicability.

Testing is required at only one EUT supply voltage and frequency.

Applicable to ports listed above and intended to connect to cables longer than 3 m

Limits		
Frequency (MHz)	QP (dBuV)	AV (dBuV)
0.15 - 0.50	84 – 74	74 – 64
0.50 - 30	74	64

Remarks:

The limit decreases linearly with the logarithm of the frequency in the range 0.15 MHz~0.50 MHz.

4.4. Test Procedure

Telecommunication Port:

The mains voltage shall be supplied to the EUT via the LISN when the measurement of telecommunication port is performed. The common mode disturbances at the telecommunication port shall be connected to the ISN, which is 150 ohm impedance.

Both alternative cables are tested related to the LCL requested. The measurement range is from 150kHz to 30MHz. The bandwidth of measurement is set to 9kHz.

The 75dB LCL ISN is used for cat. 6 cable, the 65dB LCL ISN is used for cat. 5 cable, 55dB LCL ISN is used for cat. 3.

4.5. Deviation from Test Standard

No deviation.

4.6. Test Result

Site : SR1	Time : 2016/08/19 - 16:40
Limit : ISN_Voltage_B_00M_QP	Margin : 10
EUT : Network Camera	Probe : TESEQ_T8 - Line1
Power : AC 230V/50Hz to DC 12V	Note : Mode 1,ISN 10M

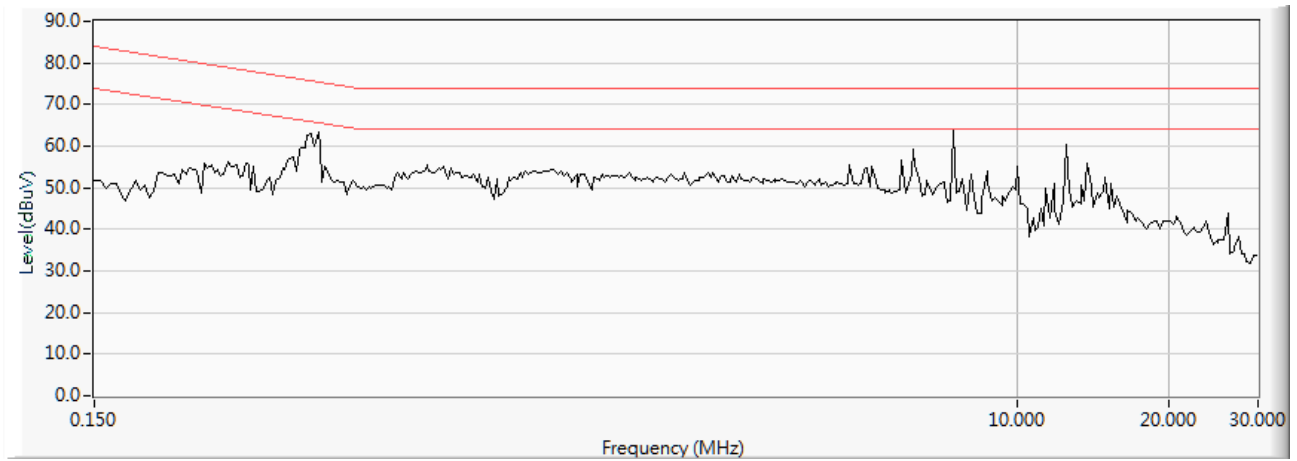

Site : SR1	Time : 2016/08/19 - 16:41
Limit : ISN_Voltage_B_00M_QP	Margin : 0
EUT : Network Camera	Probe : TESEQ_T8 - Line1
Power : AC 230V/50Hz to DC 12V	Note : Mode 1,ISN 10M

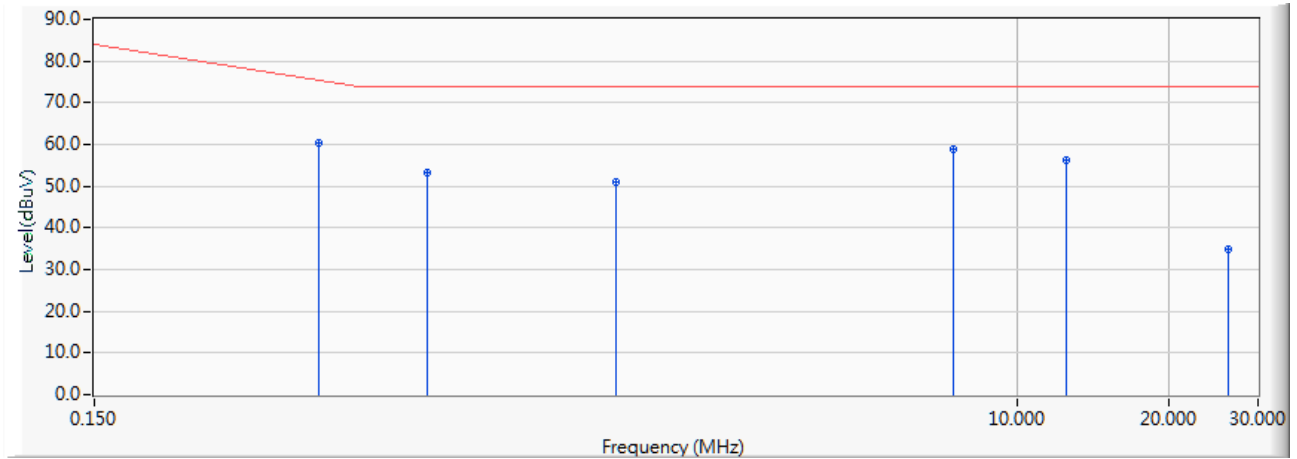

		Frequency (MHz)	Correct Factor (dB)	Reading Level (dBuV)	Measure Level (dBuV)	Margin (dB)	Limit (dBuV)	Detector Type
1		0.416	9.835	50.720	60.555	-15.845	76.400	QUASIPeAK
2		0.685	9.787	43.560	53.347	-20.653	74.000	QUASIPeAK
3		1.611	9.701	41.250	50.951	-23.049	74.000	QUASIPeAK
4	*	7.498	9.704	49.220	58.924	-15.076	74.000	QUASIPeAK
5		12.502	9.810	46.360	56.170	-17.830	74.000	QUASIPeAK
6		26.248	10.266	24.540	34.806	-39.194	74.000	QUASIPeAK

Note:

1. All Reading Levels are Quasi-Peak and average value.
2. " * ", means this data is the worst emission level.
3. Measurement Level = Reading Level + Correct Factor

Site : SR1	Time : 2016/08/19 - 16:41
Limit : ISN_Voltage_B_00M_AV	Margin : 0
EUT : Network Camera	Probe : TESEQ_T8 - Line1
Power : AC 230V/50Hz to DC 12V	Note : Mode 1,ISN 10M

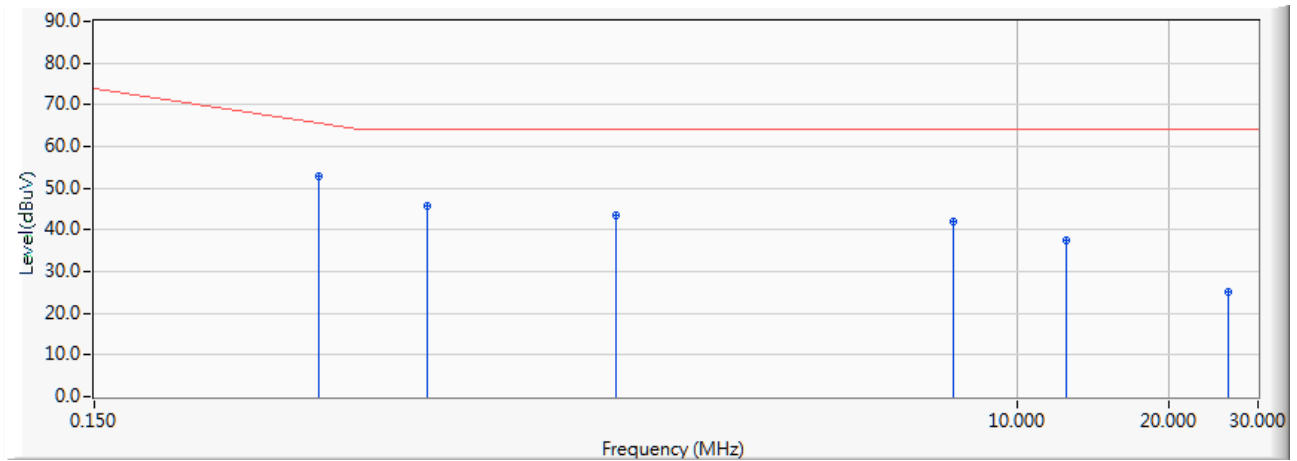

		Frequency (MHz)	Correct Factor (dB)	Reading Level (dBuV)	Measure Level (dBuV)	Margin (dB)	Limit (dBuV)	Detector Type
1	*	0.416	9.835	43.130	52.965	-13.435	66.400	AVERAGE
2		0.685	9.787	36.000	45.787	-18.213	64.000	AVERAGE
3		1.611	9.701	33.620	43.321	-20.679	64.000	AVERAGE
4		7.498	9.704	32.110	41.814	-22.186	64.000	AVERAGE
5		12.502	9.810	27.790	37.600	-26.400	64.000	AVERAGE
6		26.248	10.266	14.720	24.986	-39.014	64.000	AVERAGE

Note:

1. All Reading Levels are Quasi-Peak and average value.
2. " * ", means this data is the worst emission level.
3. Measurement Level = Reading Level + Correct Factor

Site : SR1	Time : 2016/08/19 - 16:42
Limit : ISN_Voltage_B_00M_QP	Margin : 10
EUT : Network Camera	Probe : TESEQ_T8 - Line1
Power : AC 230V/50Hz to DC 12V	Note : Mode 1,ISN 100M

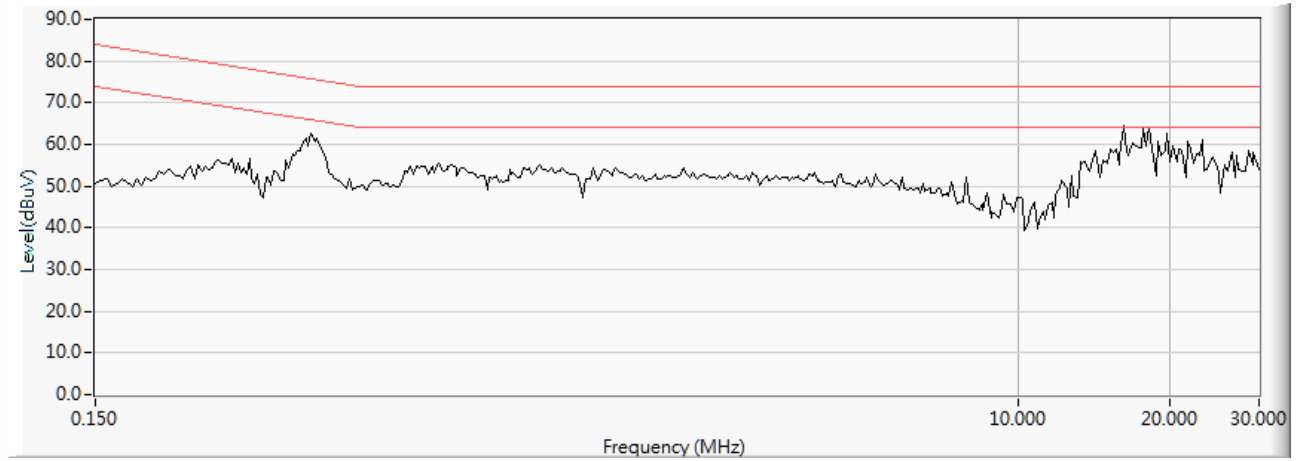

Site : SR1	Time : 2016/08/19 - 16:44
Limit : ISN_Voltage_B_00M_QP	Margin : 0
EUT : Network Camera	Probe : TESEQ_T8 - Line1
Power : AC 230V/50Hz to DC 12V	Note : Mode 1,ISN 100M

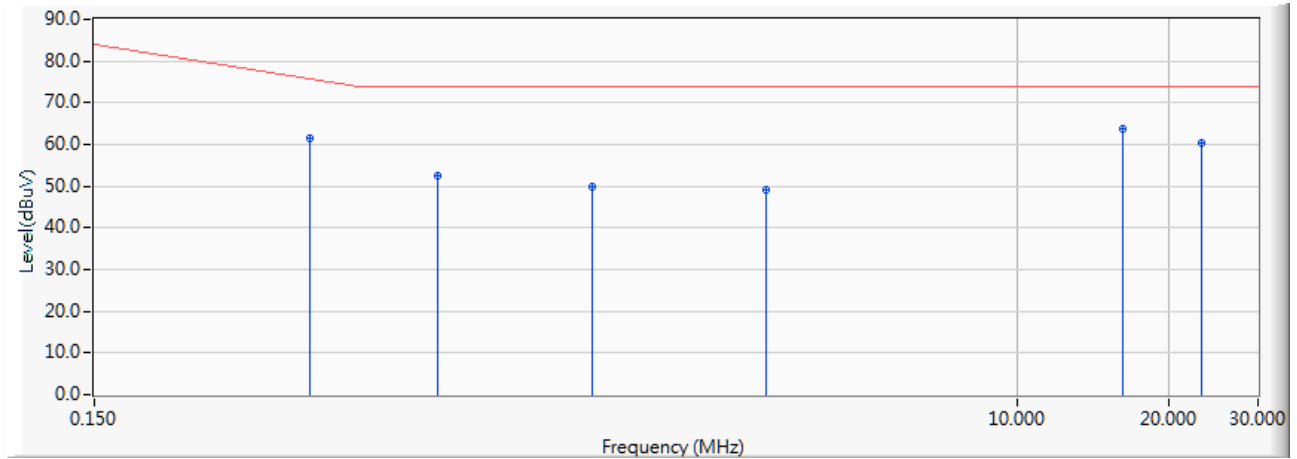

		Frequency (MHz)	Correct Factor (dB)	Reading Level (dBuV)	Measure Level (dBuV)	Margin (dB)	Limit (dBuV)	Detector Type
1		0.400	9.844	51.480	61.325	-15.532	76.857	QUASIPeAK
2		0.716	9.754	42.820	52.573	-21.427	74.000	QUASIPeAK
3		1.451	9.706	40.240	49.946	-24.054	74.000	QUASIPeAK
4		3.193	9.669	39.590	49.259	-24.741	74.000	QUASIPeAK
5	*	16.228	9.911	53.670	63.581	-10.419	74.000	QUASIPeAK
6		23.130	10.115	50.360	60.475	-13.525	74.000	QUASIPeAK

Note:

1. All Reading Levels are Quasi-Peak and average value.
2. " * ", means this data is the worst emission level.
3. Measurement Level = Reading Level + Correct Factor

Site : SR1	Time : 2016/08/19 - 16:44
Limit : ISN_Voltage_B_00M_AV	Margin : 0
EUT : Network Camera	Probe : TESEQ_T8 - Line1
Power : AC 230V/50Hz to DC 12V	Note : Mode 1,ISN 100M

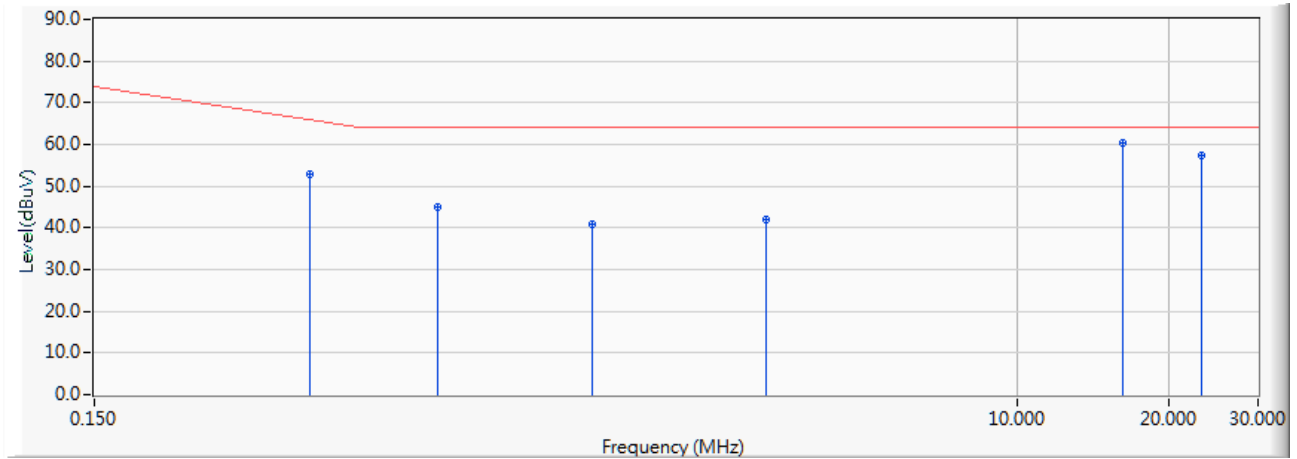

	Frequency (MHz)	Correct Factor (dB)	Reading Level (dBuV)	Measure Level (dBuV)	Margin (dB)	Limit (dBuV)	Detector Type
1	0.400	9.844	43.000	52.845	-14.012	66.857	AVERAGE
2	0.716	9.754	35.420	45.173	-18.827	64.000	AVERAGE
3	1.451	9.706	31.090	40.796	-23.204	64.000	AVERAGE
4	3.193	9.669	32.280	41.949	-22.051	64.000	AVERAGE
5	* 16.228	9.911	50.620	60.531	-3.469	64.000	AVERAGE
6	23.130	10.115	47.170	57.285	-6.715	64.000	AVERAGE

Note:

1. All Reading Levels are Quasi-Peak and average value.
2. " * ", means this data is the worst emission level.
3. Measurement Level = Reading Level + Correct Factor

Site : SR1	Time : 2016/08/19 - 17:33
Limit : ISN_Voltage_B_00M_QP	Margin : 10
EUT : Network Camera	Probe : TESEQ_T8 - Line1
Power : PoE	Note : Mode 2,ISN 10M

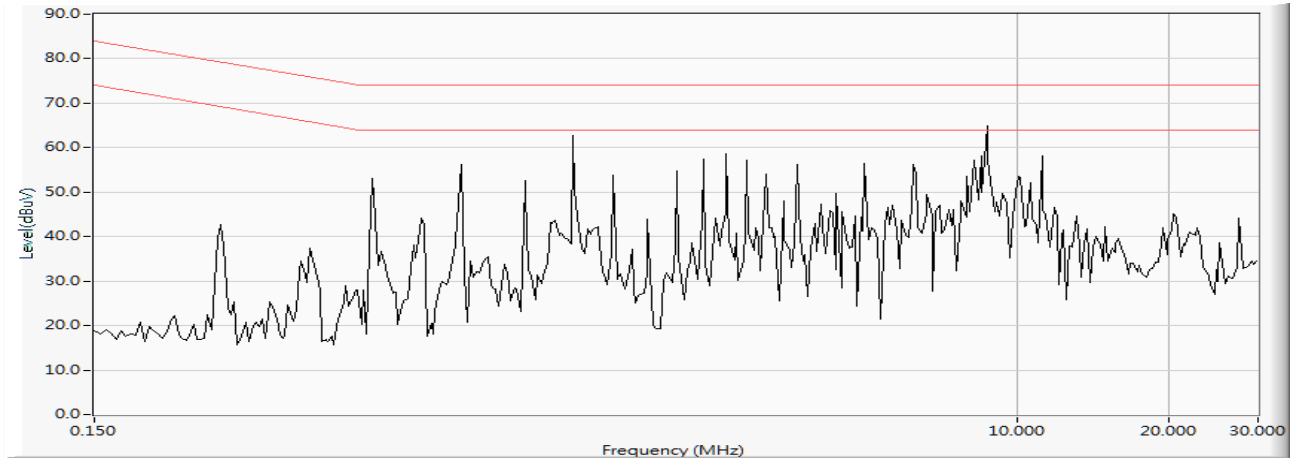

Site : SR1	Time : 2016/08/19 - 17:34
Limit : ISN_Voltage_B_00M_QP	Margin : 0
EUT : Network Camera	Probe : TESEQ_T8 - Line1
Power : PoE	Note : Mode 2,ISN 10M

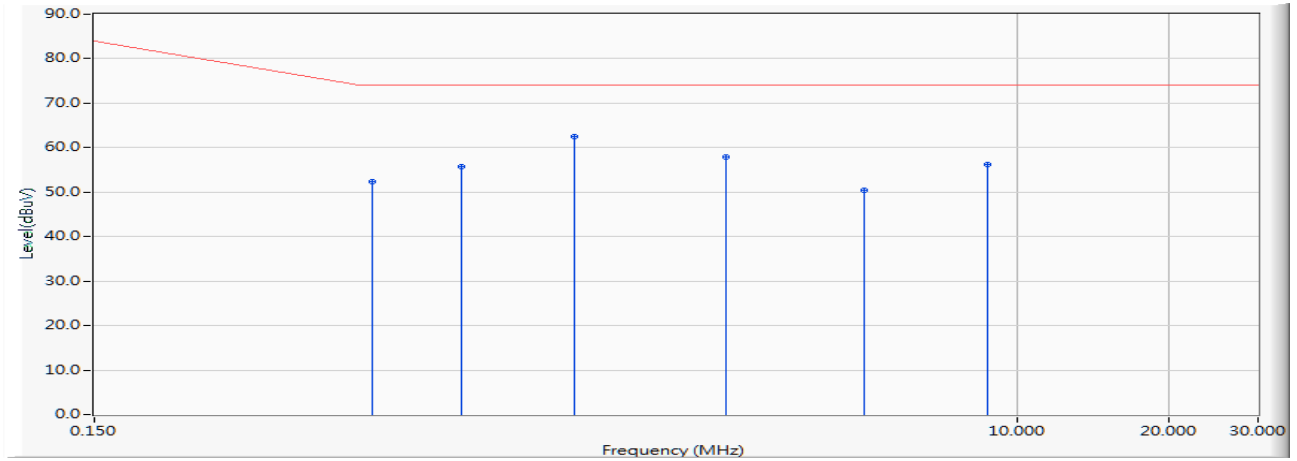

		Frequency (MHz)	Correct Factor (dB)	Reading Level (dBuV)	Measure Level (dBuV)	Margin (dB)	Limit (dBuV)	Detector Type
1		0.533	9.866	42.520	52.386	-21.614	74.000	QUASIPeAK
2		0.798	9.745	46.080	55.825	-18.175	74.000	QUASIPeAK
3	*	1.330	9.712	52.670	62.382	-11.618	74.000	QUASIPeAK
4		2.662	9.674	48.130	57.804	-16.196	74.000	QUASIPeAK
5		5.002	9.681	40.670	50.351	-23.649	74.000	QUASIPeAK
6		8.752	9.729	46.460	56.189	-17.811	74.000	QUASIPeAK

Note:

1. All Reading Levels are Quasi-Peak and average value.
2. " * ", means this data is the worst emission level.
3. Measurement Level = Reading Level + Correct Factor

Site : SR1	Time : 2016/08/19 - 17:34
Limit : ISN_Voltage_B_00M_AV	Margin : 0
EUT : Network Camera	Probe : TESEQ_T8 - Line1
Power : PoE	Note : Mode 2,ISN 10M

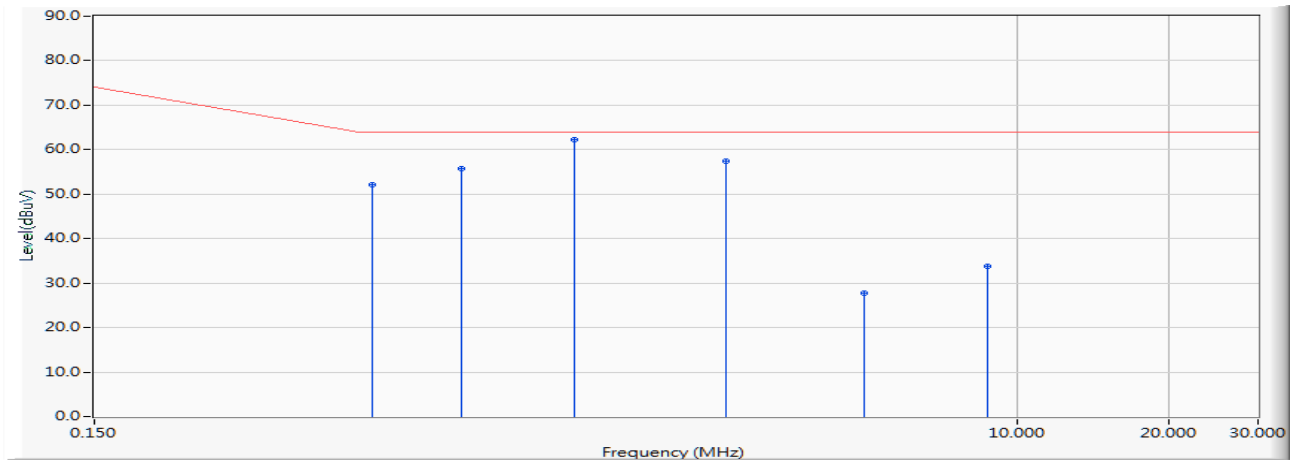

		Frequency (MHz)	Correct Factor (dB)	Reading Level (dBuV)	Measure Level (dBuV)	Margin (dB)	Limit (dBuV)	Detector Type
1		0.533	9.866	42.350	52.216	-11.784	64.000	AVERAGE
2		0.798	9.745	46.000	55.745	-8.255	64.000	AVERAGE
3	*	1.330	9.712	52.600	62.312	-1.688	64.000	AVERAGE
4		2.662	9.674	47.680	57.354	-6.646	64.000	AVERAGE
5		5.002	9.681	18.180	27.861	-36.139	64.000	AVERAGE
6		8.752	9.729	24.010	33.739	-30.261	64.000	AVERAGE

Note:

1. All Reading Levels are Quasi-Peak and average value.
2. " * ", means this data is the worst emission level.
3. Measurement Level = Reading Level + Correct Factor

Site : SR1	Time : 2016/08/19 - 17:35
Limit : ISN_Voltage_B_00M_QP	Margin : 10
EUT : Network Camera	Probe : TESEQ_T8 - Line1
Power : PoE	Note : Mode 2,ISN 100M

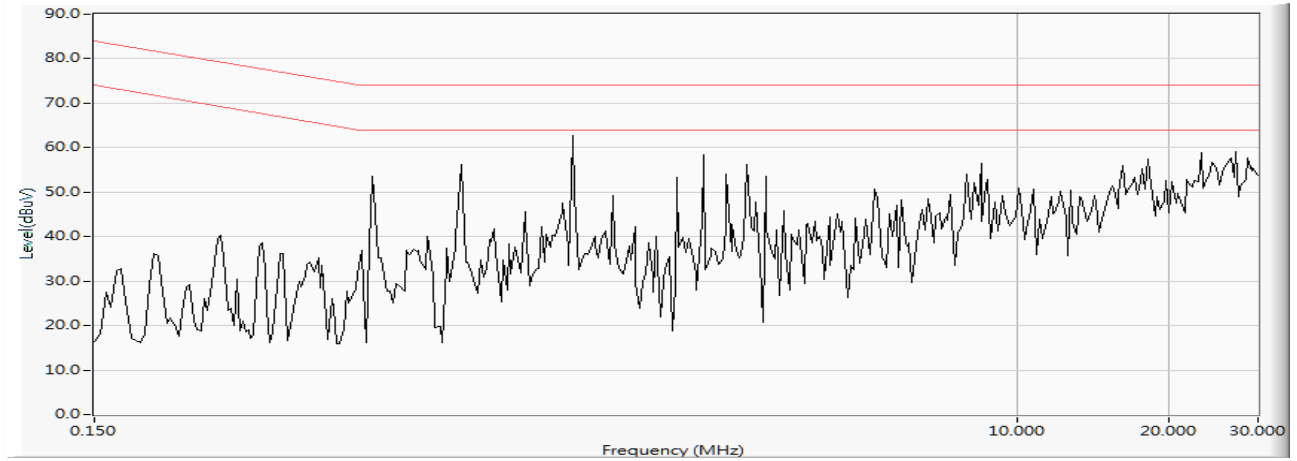

Site : SR1	Time : 2016/08/19 - 17:36
Limit : ISN_Voltage_B_00M_QP	Margin : 0
EUT : Network Camera	Probe : TESEQ_T8 - Line1
Power : PoE	Note : Mode 2,ISN 100M

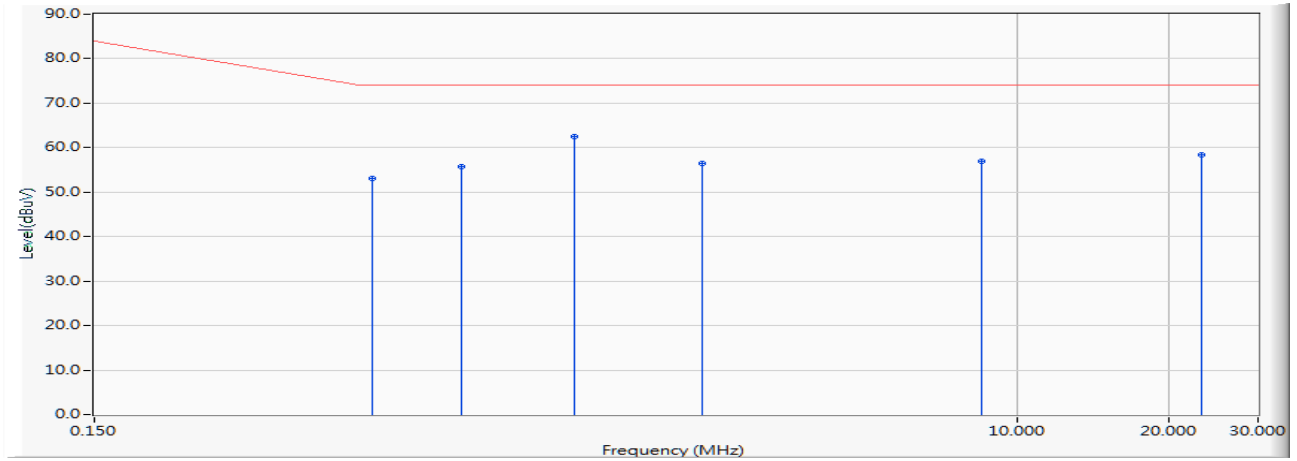

		Frequency (MHz)	Correct Factor (dB)	Reading Level (dBuV)	Measure Level (dBuV)	Margin (dB)	Limit (dBuV)	Detector Type
1		0.533	9.866	43.160	53.026	-20.974	74.000	QUASIPeAK
2		0.798	9.745	46.040	55.785	-18.215	74.000	QUASIPeAK
3	*	1.330	9.712	52.730	62.442	-11.558	74.000	QUASIPeAK
4		2.396	9.682	46.790	56.472	-17.528	74.000	QUASIPeAK
5		8.517	9.726	47.200	56.926	-17.074	74.000	QUASIPeAK
6		23.127	10.115	48.170	58.285	-15.715	74.000	QUASIPeAK

Note:

1. All Reading Levels are Quasi-Peak and average value.
2. " * ", means this data is the worst emission level.
3. Measurement Level = Reading Level + Correct Factor

Site : SR1	Time : 2016/08/19 - 17:36
Limit : ISN_Voltage_B_00M_AV	Margin : 0
EUT : Network Camera	Probe : TESEQ_T8 - Line1
Power : PoE	Note : Mode 2,ISN 100M

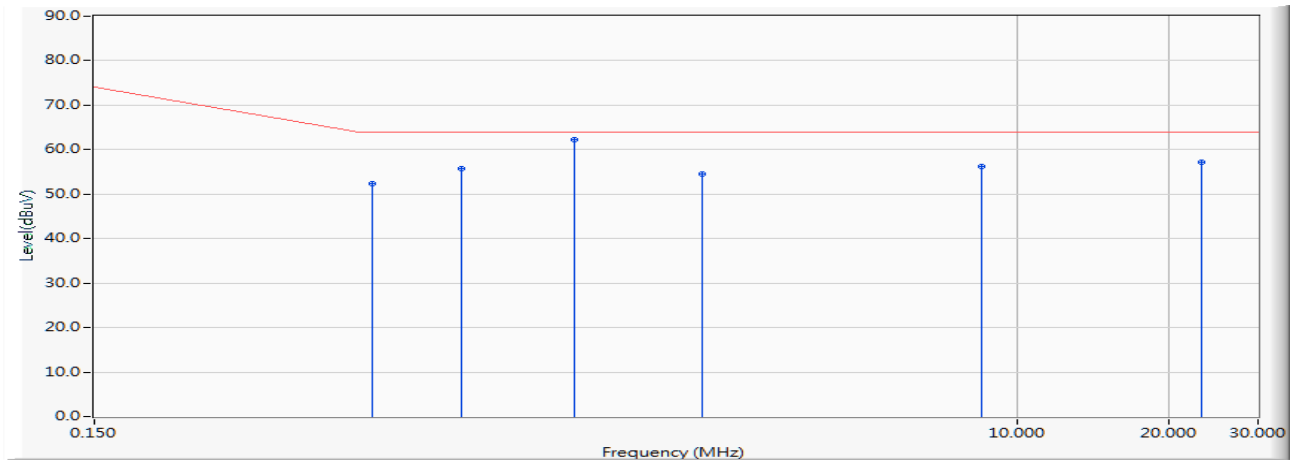

		Frequency (MHz)	Correct Factor (dB)	Reading Level (dBuV)	Measure Level (dBuV)	Margin (dB)	Limit (dBuV)	Detector Type
1		0.533	9.866	42.510	52.376	-11.624	64.000	AVERAGE
2		0.798	9.745	46.000	55.745	-8.255	64.000	AVERAGE
3	*	1.330	9.712	52.650	62.362	-1.638	64.000	AVERAGE
4		2.396	9.682	44.960	54.642	-9.358	64.000	AVERAGE
5		8.517	9.726	46.480	56.206	-7.794	64.000	AVERAGE
6		23.127	10.115	47.020	57.135	-6.865	64.000	AVERAGE

Note:

1. All Reading Levels are Quasi-Peak and average value.
2. " * ", means this data is the worst emission level.
3. Measurement Level = Reading Level + Correct Factor

4.7. Test Photograph

Test Mode : Mode 1: FE9382-EHV, DC

Description : Front View of ISN Test



Test Mode : Mode 1: FE9382-EHV, DC

Description : Back View of ISN Test



Test Mode : Mode 1: FE9382-EHV, DC

Description : Back View of ISN Test



Test Mode : Mode 2: FE9382-EHV, PoE

Description : Front View of ISN Test



Test Mode : Mode 2: FE9382-EHV, PoE

Description : Back View of ISN Test



Test Mode : Mode 2: FE9382-EHV, PoE

Description : Back View of ISN Test



5. Radiated Emission

5.1. Test Specification

According to EMC Standard : EN 55022 and AS/NZS CISPR 22 and EN55032

5.2. Test Setup

Under 1GHz Test Setup

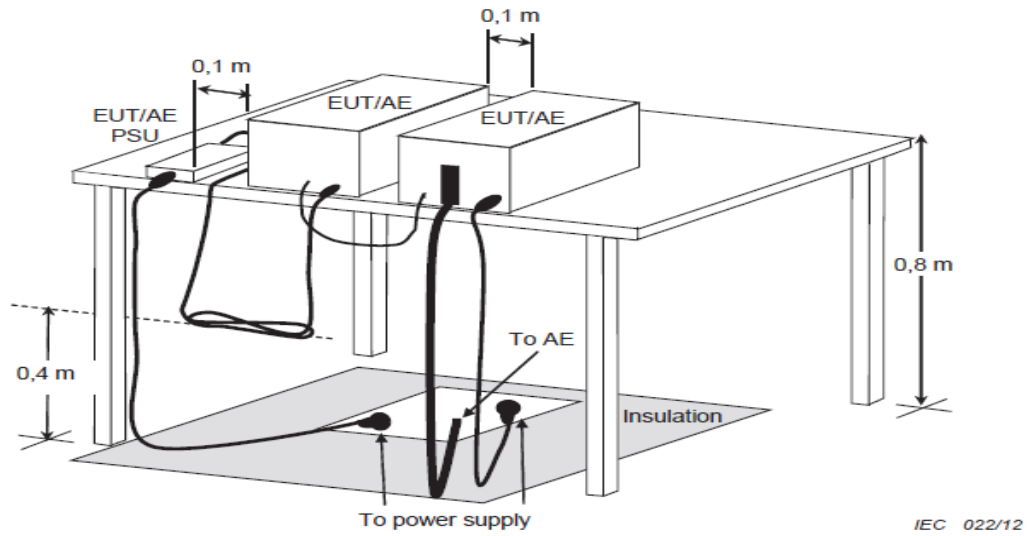

Under 1GHz Test Setup:

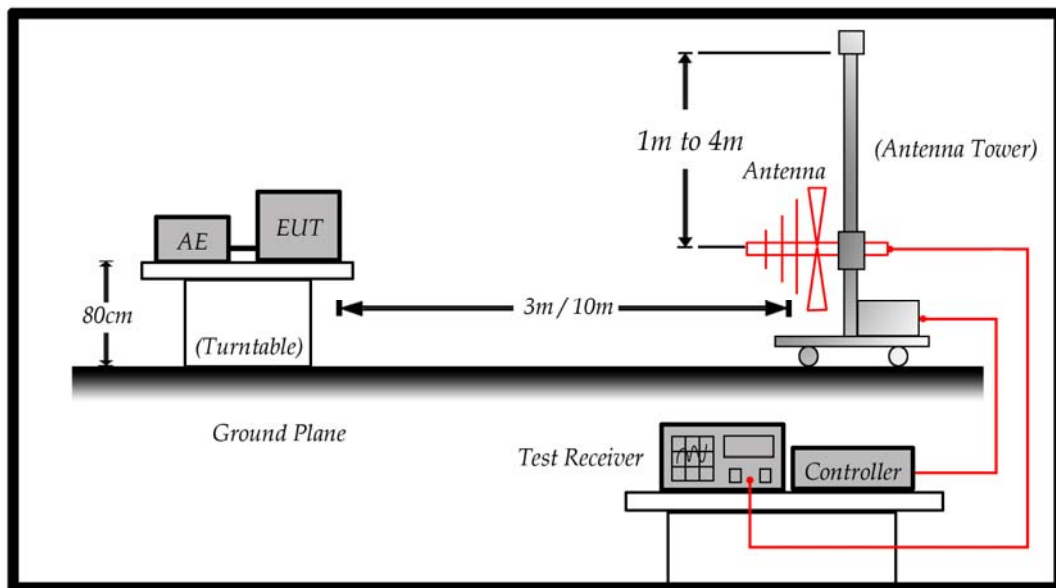

Above 1GHz Test Setup:

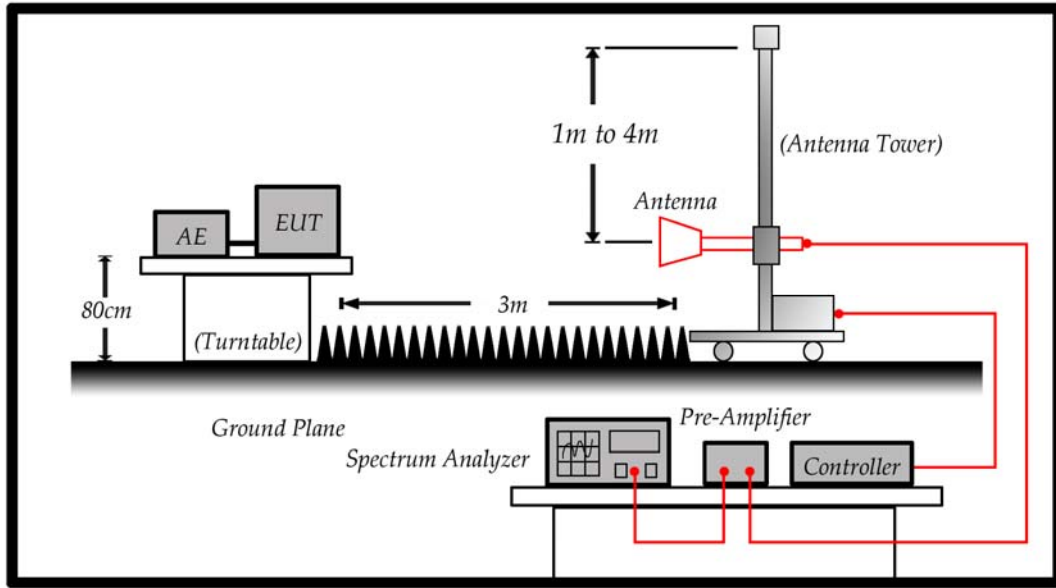

5.3. Limit

Radiated emissions at frequencies up to 1 GHz
for Class B equipment

Frequency range MHz	Measurement		Class B limits dB(µV/m)
	Distance m	Detector type/ Bandwidth	OATS / SAC
30-230	10	Quasi Peak / 120 KHz	30
230-1000			37
30-230	3		40
230-1000			47
Apply only 3m or 10m across the entire frequency range			

Radiated emissions at frequencies above 1 GHz
for Class B equipment

Frequency range MHz	Measurement		Class B limits dB(µV/m)
	Distance m	Detector type/ Bandwidth	OATS / SAC
1000-3000	3	Average / 1 MHz	50
3000-6000			54
1000-3000		Peak / 1 MHz	70
3000-6000			74
Both apply across the frequency range from 1000 MHz to the highest required frequency of measurement derived from			

Limits		
Frequency (MHz)	Distance (m)	dBuV/m
30 – 230	10	30
230 – 1000	10	37

Limits			
Frequency (GHz)	Distance (m)	Peak (dBuV/m)	Average (dBuV/m)
1 – 3	3	70	50
3 – 6	3	74	54

Remark:

1. The tighter limit shall apply at the edge between two frequency bands.
2. Distance refers to the distance in meters between the measuring instrument antenna and the closed point of any part of the device or system.

Highest frequency generated or used in the device or on which the device operates or tunes (MHz)	Upper frequency of measurement range (MHz)
Below 108	1000
108 – 500	2000
500 – 1000	5000
Above 1000	5 th harmonic of the highest frequency or 6 GHz, whichever is lower

5.4. Test Procedure

The EUT and its simulators are placed on a turn table which is 0.8 meter above ground. The turn table can rotate 360 degrees to determine the position of the maximum emission level. The EUT was positioned such that the distance from antenna to the EUT was 3/10 meters. The antenna can move up and down between 1 meter and 4 meters to find out the maximum emission level.

Both horizontal and vertical polarization of the antenna are set on measurement. In order to find the maximum emission, all of the interface cables must be manipulated on radiated measurement.

Radiated emissions were investigated over the frequency range from 30MHz to 1GHz using a receiver bandwidth of 120kHz and above 1GHz using a receiver bandwidth of 1MHz.

30MHz to 1GHz Radiated was performed at an antenna to EUT distance of 10 meters.

Above 1GHz Radiated was performed at an antenna to EUT distance of 3 meters.

It is placed with absorb on the ground between EUT and Antenna.

5.5. Deviation from Test Standard

No deviation.

5.6. Test Result

Site : Site1	Time : 2016/08/18 - 07:19
Limit : CISPR_B_10M_QP	Margin : 6
EUT : Network Camera	Probe : Site1_CBL6112_10M_1506 - HORIZONTAL
Power : AC 230V/50Hz to DC 12V to DC 12V	Note : Mode 1

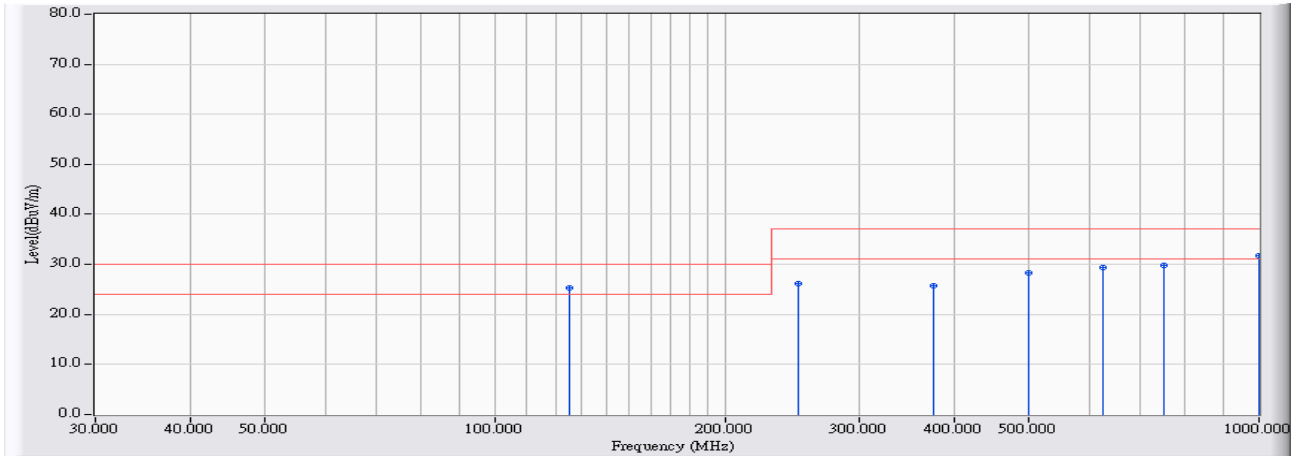

		Frequency (MHz)	Correct Factor (dB)	Reading Level (dBuV)	Measure Level (dBuV/m)	Margin (dB)	Limit (dBuV/m)	Detector Type
1	*	124.994	14.342	10.973	25.315	-4.685	30.000	QUASPEAK
2		249.994	15.846	10.286	26.132	-10.868	37.000	QUASPEAK
3		374.994	19.397	6.410	25.807	-11.193	37.000	QUASPEAK
4		499.995	22.371	5.887	28.258	-8.742	37.000	QUASPEAK
5		625.002	24.418	4.992	29.410	-7.590	37.000	QUASPEAK
6		750.001	26.020	3.790	29.810	-7.190	37.000	QUASPEAK
7		999.992	29.600	2.108	31.708	-5.292	37.000	QUASPEAK

Note:

1. All Readings below 1GHz are Quasi-Peak, above are performed with peak and/or average measurements as necessary.
2. " * ", means this data is the worst emission level.
3. Measurement Level = Reading Level + Correct Factor

Site : Site1	Time : 2016/08/18 - 07:40
Limit : CISPR_B_10M_QP	Margin : 6
EUT : Network Camera	Probe : Site1_CBL6112_10M_1506 - VERTICAL
Power : AC 230V/50Hz to DC 12V to DC 12V	Note : Mode 1

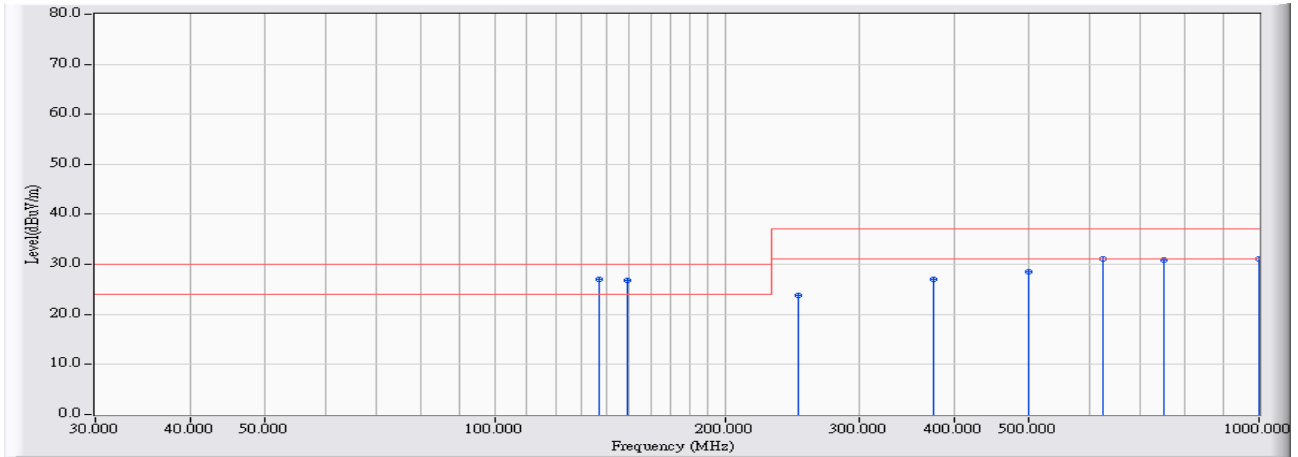

		Frequency (MHz)	Correct Factor (dB)	Reading Level (dBuV)	Measure Level (dBuV/m)	Margin (dB)	Limit (dBuV/m)	Detector Type
1	*	137.201	13.815	13.106	26.921	-3.079	30.000	QUASIPeAK
2		148.991	12.986	13.831	26.817	-3.183	30.000	QUASIPeAK
3		250.004	15.846	8.015	23.861	-13.139	37.000	QUASIPeAK
4		374.991	19.397	7.733	27.130	-9.870	37.000	QUASIPeAK
5		499.995	22.371	6.194	28.565	-8.435	37.000	QUASIPeAK
6		624.994	24.418	6.706	31.124	-5.876	37.000	QUASIPeAK
7		749.992	26.020	4.842	30.862	-6.138	37.000	QUASIPeAK
8		999.999	29.600	1.466	31.066	-5.934	37.000	QUASIPeAK

Note:

1. All Readings below 1GHz are Quasi-Peak, above are performed with peak and/or average measurements as necessary.
2. " * ", means this data is the worst emission level.
3. Measurement Level = Reading Level + Correct Factor

Site : site1	Time : 2016/08/18 - 05:29
Limit : CISPR_B_10M_QP	Margin : 6
EUT : Network Camera	Probe : Site1_CBL6112_10M_1506 - HORIZONTAL
Power : PoE	Note : Mode 2

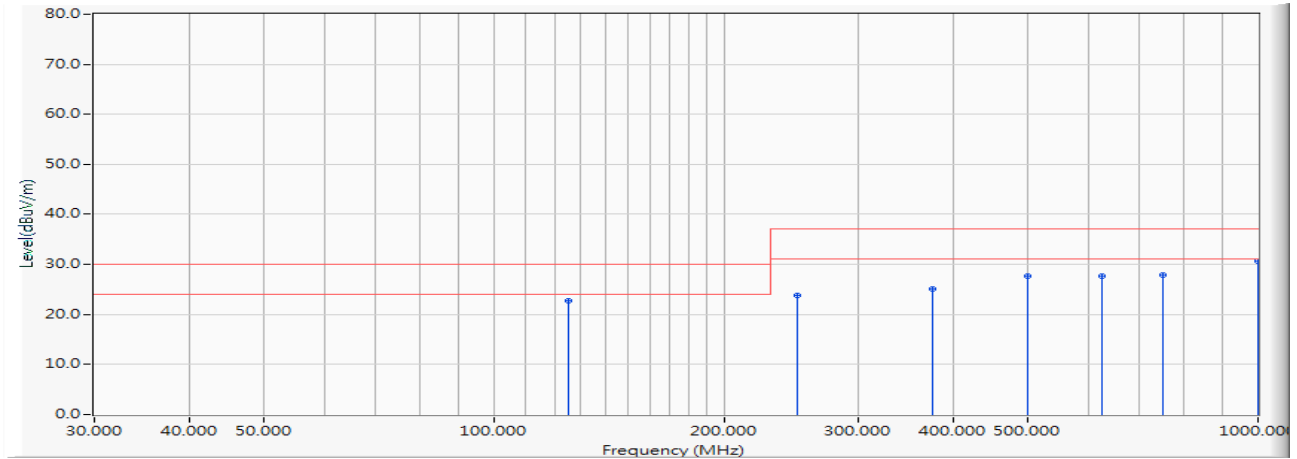

	Frequency (MHz)	Correct Factor (dB)	Reading Level (dBuV)	Measure Level (dBuV/m)	Margin (dB)	Limit (dBuV/m)	Detector Type
1	125.000	14.342	8.400	22.742	-7.258	30.000	QUASIPeAK
2	250.000	15.846	7.900	23.746	-13.254	37.000	QUASIPeAK
3	375.000	19.397	5.800	25.197	-11.803	37.000	QUASIPeAK
4	500.000	22.371	5.200	27.571	-9.429	37.000	QUASIPeAK
5	625.000	24.418	3.300	27.718	-9.282	37.000	QUASIPeAK
6	750.000	26.020	1.900	27.920	-9.080	37.000	QUASIPeAK
7	* 1000.000	29.600	1.100	30.700	-6.300	37.000	QUASIPeAK

Note:

1. All Readings below 1GHz are Quasi-Peak, above are performed with peak and/or average measurements as necessary.
2. " * ", means this data is the worst emission level.
3. Measurement Level = Reading Level + Correct Factor

Site : site1	Time : 2016/08/18 - 05:53
Limit : CISPR_B_10M_QP	Margin : 6
EUT : Network Camera	Probe : Site1_CBL6112_10M_1506 - VERTICAL
Power : PoE	Note : Mode 2

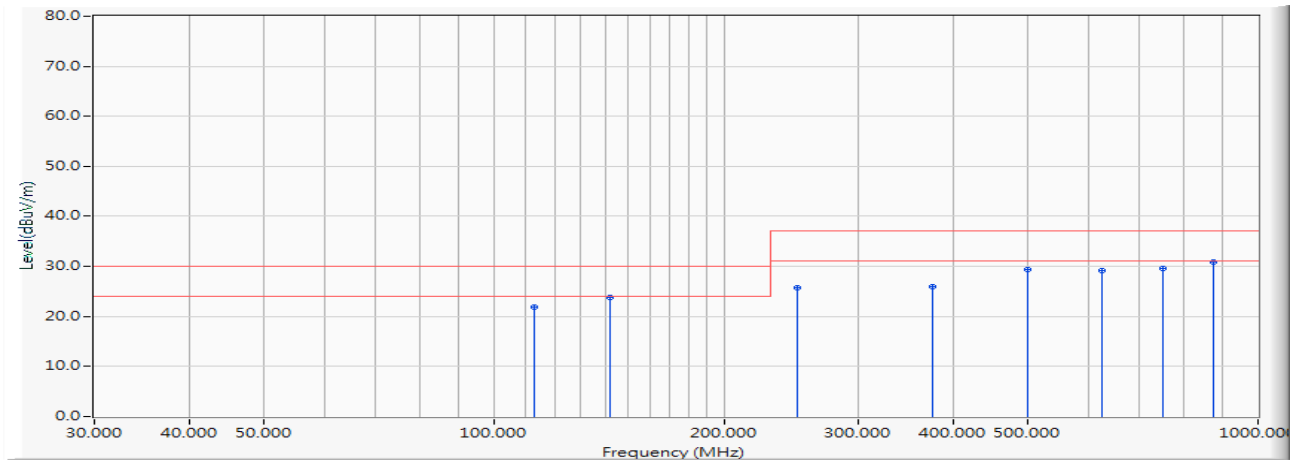

	Frequency (MHz)	Correct Factor (dB)	Reading Level (dBuV)	Measure Level (dBuV/m)	Margin (dB)	Limit (dBuV/m)	Detector Type
1	113.045	14.378	7.600	21.978	-8.022	30.000	QUASIPeAK
2	141.902	13.551	10.300	23.851	-6.149	30.000	QUASIPeAK
3	250.000	15.846	9.900	25.746	-11.254	37.000	QUASIPeAK
4	375.000	19.397	6.600	25.997	-11.003	37.000	QUASIPeAK
5	500.000	22.371	7.000	29.371	-7.629	37.000	QUASIPeAK
6	625.000	24.418	4.800	29.218	-7.782	37.000	QUASIPeAK
7	750.000	26.020	3.600	29.620	-7.380	37.000	QUASIPeAK
8	* 875.000	27.541	3.400	30.941	-6.059	37.000	QUASIPeAK

Note:

1. All Readings below 1GHz are Quasi-Peak, above are performed with peak and/or average measurements as necessary.
2. " * ", means this data is the worst emission level.
3. Measurement Level = Reading Level + Correct Factor

Site: CB7	Time: 2016/08/19 - 01:30
Limit: EN55022_B_(Above_1G)	Margin: 0
Probe: CB7_Horn_9120D_1511	Polarity: Horizontal
EUT: Network Camera	Power: AC 230V/50Hz to DC 12V
Note: Mode 1	

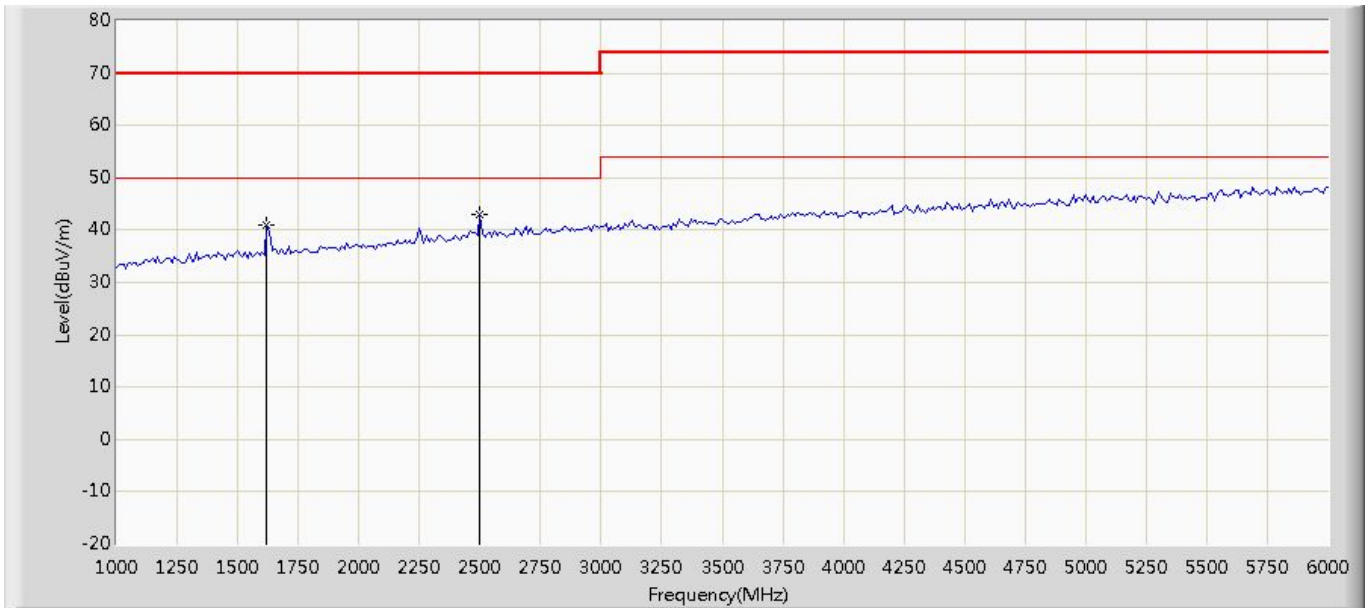

No	Flag	Mark	Frequency (MHz)	Measure Level (dBuV/m)	Reading Level (dBuV)	Over Limit (dB)	Limit (dBuV/m)	Factor	Type
1			1620.000	41.050	37.527	-28.950	70.000	3.523	PK
2		*	2500.000	42.970	36.097	-27.030	70.000	6.873	PK

Note:

1. All Readings below 1GHz are Quasi-Peak, above are performed with peak and/or average measurements as necessary.
2. " * ", means this data is the worst emission level.
3. Measurement Level = Reading Level + Factor(Probe+Cable-Amp).

Site: CB7	Time: 2016/08/19 - 01:30
Limit: EN55022_B_(Above_1G)	Margin: 0
Probe: CB7_Horn_9120D_1511	Polarity: Vertical
EUT: Network Camera	Power: AC 230V/50Hz to DC 12V
Note: Mode 1	

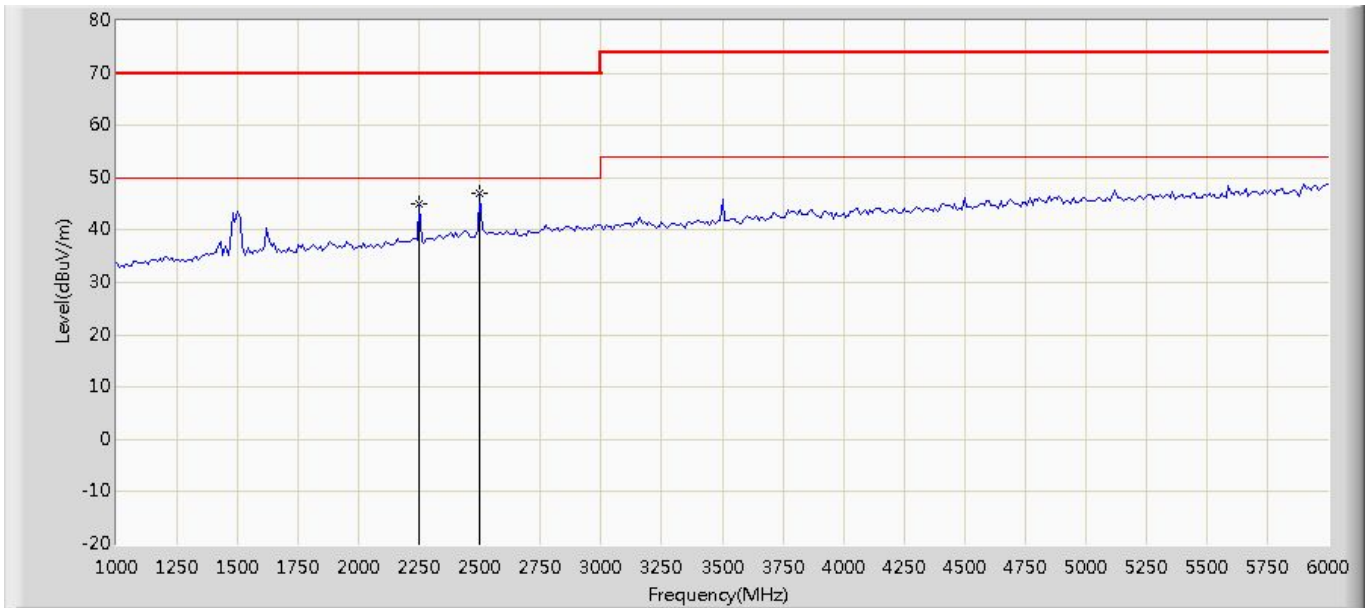

No	Flag	Mark	Frequency (MHz)	Measure Level (dBuV/m)	Reading Level (dBuV)	Over Limit (dB)	Limit (dBuV/m)	Factor	Type
1			2250.000	44.895	38.966	-25.105	70.000	5.929	PK
2		*	2500.000	46.917	40.044	-23.083	70.000	6.873	PK

Note:

1. All Readings below 1GHz are Quasi-Peak, above are performed with peak and/or average measurements as necessary.
2. " * ", means this data is the worst emission level.
3. Measurement Level = Reading Level + Factor(Probe+Cable-Amp).

Site: CB7	Time: 2016/08/19 - 01:32
Limit: EN55022_B_(Above_1G)	Margin: 0
Probe: CB7_Horn_9120D_1511	Polarity: Horizontal
EUT: Network Camera	Power: POE
Note: Mode 2	

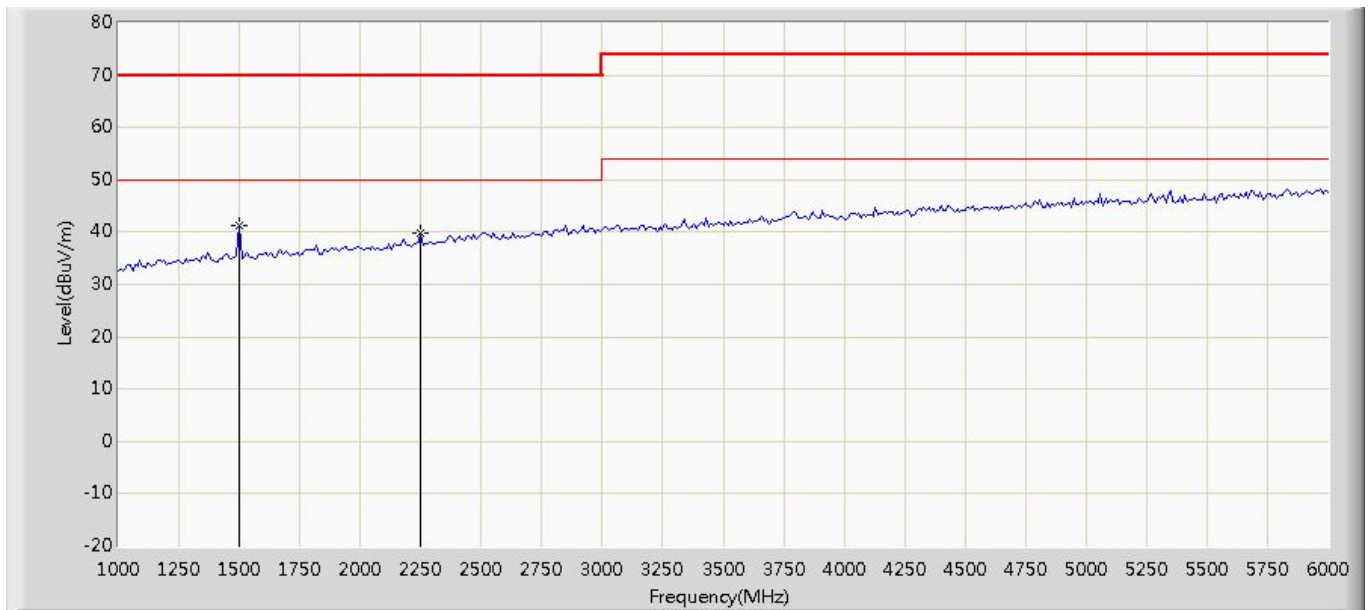

No	Flag	Mark	Frequency (MHz)	Measure Level (dBuV/m)	Reading Level (dBuV)	Over Limit (dB)	Limit (dBuV/m)	Factor	Type
1		*	1500.000	41.391	38.287	-28.609	70.000	3.104	PK
2			2250.000	39.719	33.790	-30.281	70.000	5.929	PK

Note:

1. All Readings below 1GHz are Quasi-Peak, above are performed with peak and/or average measurements as necessary.
2. " * ", means this data is the worst emission level.
3. Measurement Level = Reading Level + Factor(Probe+Cable-Amp).

Site: CB7	Time: 2016/08/19 - 01:32
Limit: EN55022_B_(Above_1G)	Margin: 0
Probe: CB7_Horn_9120D_1511	Polarity: Vertical
EUT: Network Camera	Power: POE
Note: Mode 2	

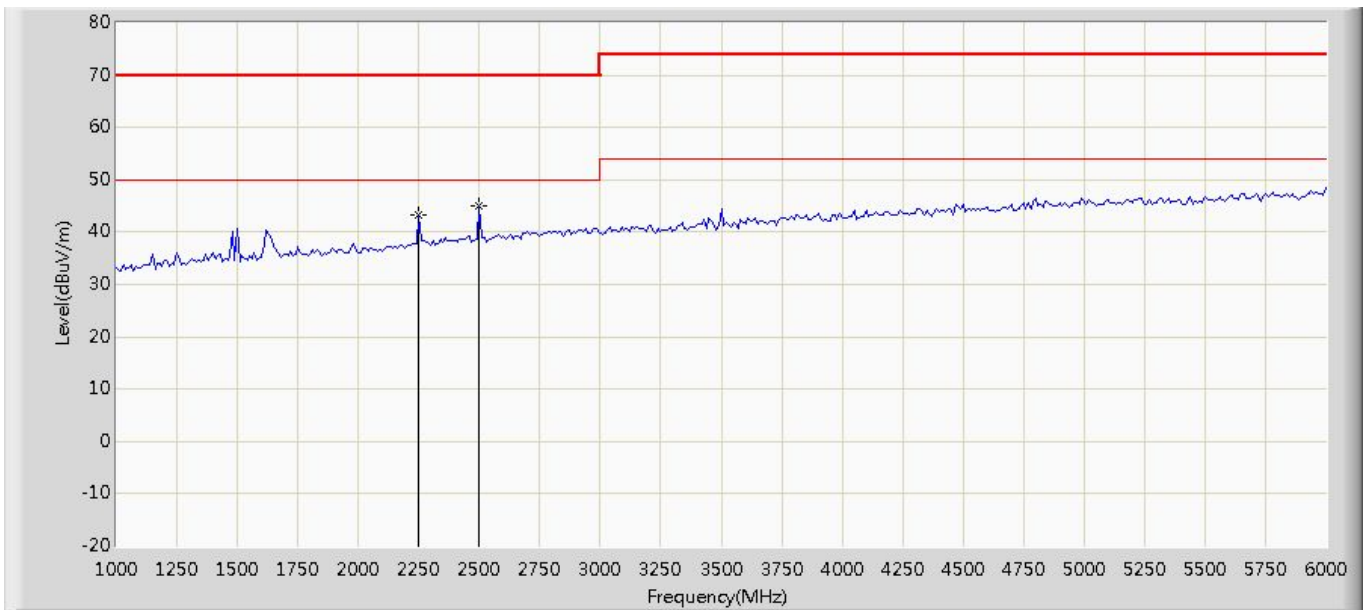

No	Flag	Mark	Frequency (MHz)	Measure Level (dBuV/m)	Reading Level (dBuV)	Over Limit (dB)	Limit (dBuV/m)	Factor	Type
1			2250.000	43.201	37.272	-26.799	70.000	5.929	PK
2		*	2500.000	44.927	38.054	-25.073	70.000	6.873	PK

Note:

1. All Readings below 1GHz are Quasi-Peak, above are performed with peak and/or average measurements as necessary.
2. " * ", means this data is the worst emission level.
3. Measurement Level = Reading Level + Factor(Probe+Cable-Amp).

5.7. Test Photograph

Test Mode : Mode 1: FE9382-EHV, DC

Description : Front View of Radiated Test



Test Mode : Mode 1: FE9382-EHV, DC

Description : Back View of Radiated Test



Test Mode : Mode 1: FE9382-EHV, DC

Description : Front View of High Frequency Radiated Test



Test Mode : Mode 2: FE9382-EHV, PoE

Description : Front View of Radiated Test



Test Mode : Mode 2: FE9382-EHV, PoE

Description : Back View of Radiated Test



Test Mode : Mode 2: FE9382-EHV, PoE

Description : Front View of High Frequency Radiated Test

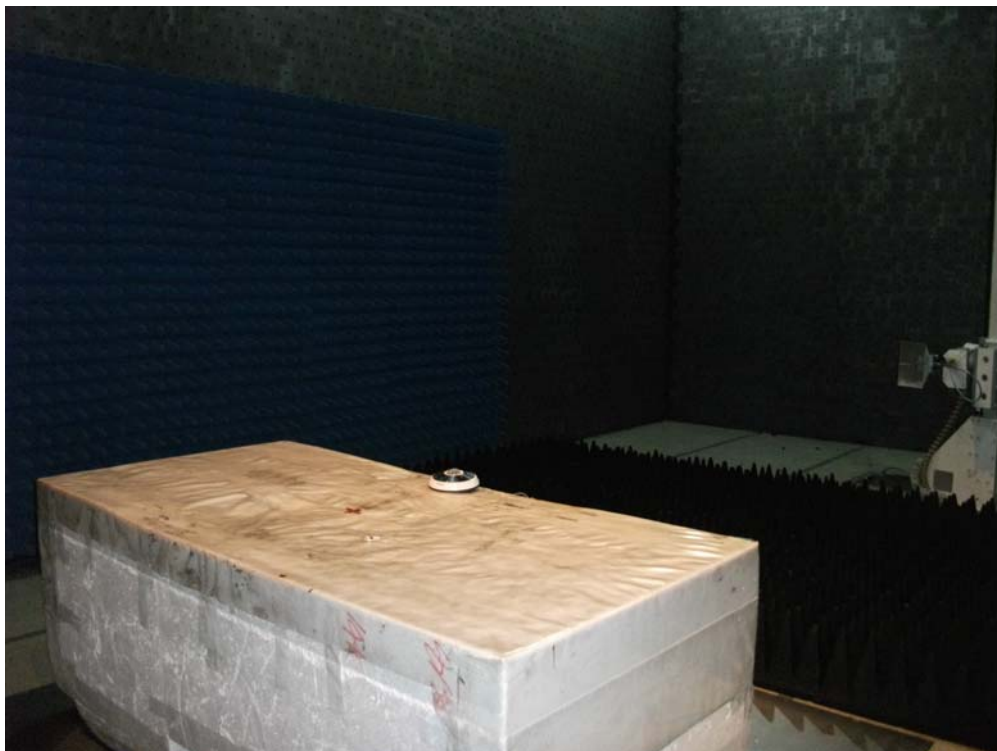

6. Electrostatic Discharge

6.1. Test Specification

According to Standard : IEC 61000-4-2

6.2. Test Setup

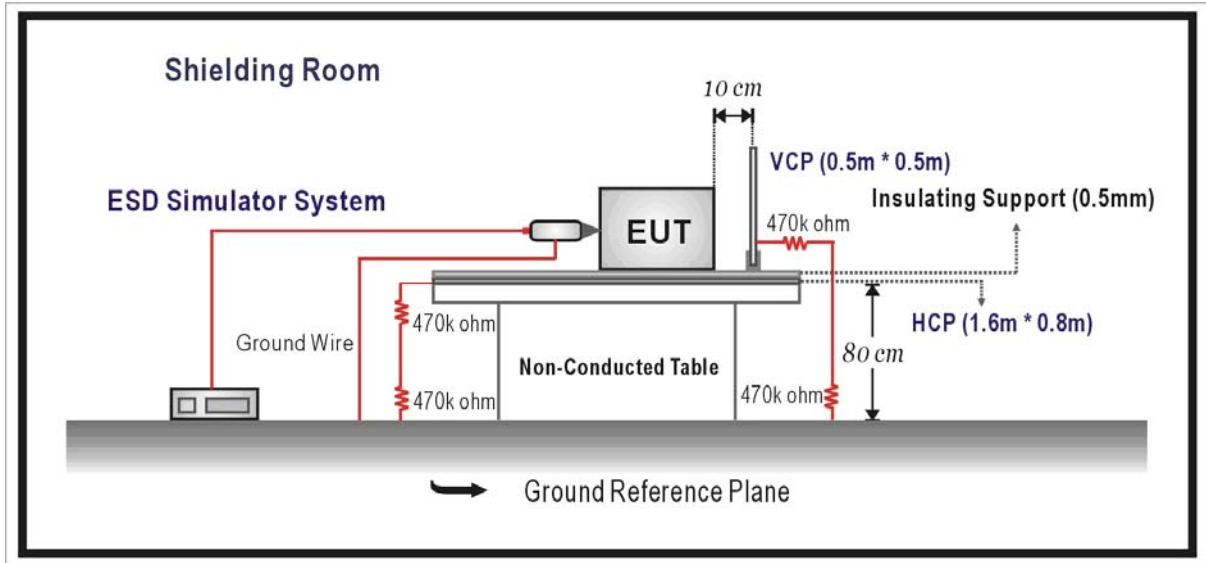

6.3. Limit

Item	Environmental Phenomena	Units	Test Specification	Performance Criteria
Enclosure Port				
	Electrostatic Discharge	kV(Charge Voltage)	±8 Air Discharge ±4 Contact Discharge	B

6.4. Test Procedure

Direct application of discharges to the EUT:

Contact discharge was applied only to conductive surfaces of the EUT.

Air discharges were applied only to non-conductive surfaces of the EUT.

During the test, it was performed with single discharges. For the single discharge time between successive single discharges will be keep longer 1 second. It was at least ten single discharges with positive and negative at the same selected point.

Indirect application of discharges to the EUT:

Vertical Coupling Plane (VCP):

The coupling plane, of dimensions 0.5m x 0.5m, is placed parallel to, and positioned at a distance 0.1m from, the EUT, with the Discharge Electrode touching the coupling plane.

The four faces of the EUT will be performed with electrostatic discharge. It was at least ten single discharges with positive and negative at the same selected point.

Horizontal Coupling Plane (HCP):

The coupling plane is placed under to the EUT. The generator shall be positioned vertically at a distance of 0.1m from the EUT, with the Discharge Electrode touching the coupling plane.

It was at least ten single discharges with positive and negative at the same selected point.

6.5. Deviation from Test Standard

No deviation.

6.6. Test Result

Product	Network Camera		
Test Item	Electrostatic Discharge		
Test Mode	Mode 1: FE9382-EHV, DC		
Date of Test	2016/08/29	Test Site	No.6 Shielded Room

Item	Amount of Discharge	Voltage	Required Criteria	Complied To Criteria (A,B,C)	Results
Air Discharge	10	+8kV	B	B	Pass
	10	-8kV	B	B	Pass
Contact Discharge	25	+4kV	B	A	Pass
	25	-4kV	B	A	Pass
Indirect Discharge (HCP)	25	+4kV	B	A	Pass
	25	-4kV	B	A	Pass
Indirect Discharge (VCP)	25	+4kV	B	A	Pass
	25	-4kV	B	A	Pass

Note:

The testing performed is from lowest level up to the highest level as required by standard, but only highest level is shown on the report.

NR: No Requirement

- Meet criteria A: Operate as intended during and after the test
- Meet criteria B: Operate as intended after the test
- Meet criteria C: Loss/Error of function
- Additional Information
 - EUT stopped operation and could / could not be reset by operator at ____ kV.
 - No false alarms or other malfunctions were observed during or after the test.

Remark:

The Contact discharges were applied at least total 200 discharges at a minimum of four test points.

Product	Network Camera		
Test Item	Electrostatic Discharge		
Test Mode	Mode 2: FE9382-EHV, PoE		
Date of Test	2016/08/29	Test Site	No.6 Shielded Room

Item	Amount of Discharge	Voltage	Required Criteria	Complied To Criteria (A,B,C)	Results
Air Discharge	10	+8kV	B	B	Pass
	10	-8kV	B	B	Pass
Contact Discharge	25	+4kV	B	A	Pass
	25	-4kV	B	A	Pass
Indirect Discharge (HCP)	25	+4kV	B	A	Pass
	25	-4kV	B	A	Pass
Indirect Discharge (VCP)	25	+4kV	B	A	Pass
	25	-4kV	B	A	Pass

Note:

The testing performed is from lowest level up to the highest level as required by standard, but only highest level is shown on the report.

NR: No Requirement

- Meet criteria A: Operate as intended during and after the test
- Meet criteria B: Operate as intended after the test
- Meet criteria C: Loss/Error of function
- Additional Information
 - EUT stopped operation and could / could not be reset by operator at ____ kV.
 - No false alarms or other malfunctions were observed during or after the test.

Remark:

The Contact discharges were applied at least total 200 discharges at a minimum of four test points.

6.7. Test Photograph

Test Mode : Mode 1: FE9382-EHV, DC

Description : ESD Test Setup



Test Mode : Mode 2: FE9382-EHV, PoE

Description : ESD Test Setup



6.8. EUT to dot photo for ESD test
Test dot : (Air Discharge)



Test dot : (Air Discharge)



Test dot: (Contact Discharge)



7. Radiated Susceptibility

7.1. Test Specification

According to Standard : IEC 61000-4-3

7.2. Test Setup

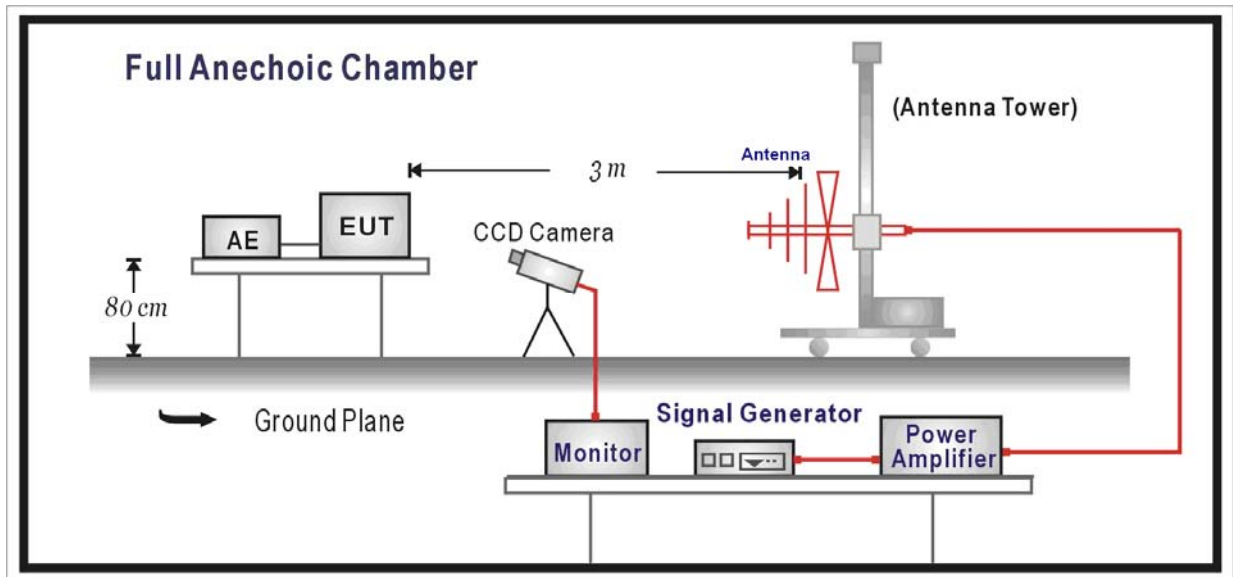

7.3. Limit

Item	Environmental Phenomena	Units	Test Specification	Performance Criteria
Enclosure Port				
	Radio-Frequency Electromagnetic Field Amplitude Modulated	MHz V/m(Un-modulated, rms) % AM (1kHz)	80-1000 3 80	A

7.4. Test Procedure

The EUT and load, which are placed on a table that is 0.8 meter above ground, are placed with one coincident with the calibration plane such that the distance from antenna to the EUT was 3 meters.

Both horizontal and vertical polarization of the antenna and four sides of the EUT are set on measurement.

In order to judge the EUT performance, a CCD camera is used to monitor EUT screen.

All the scanning conditions are as follows:

Condition of Test	Remarks
1. Field Strength	3 V/m Level 2
2. Radiated Signal	AM 80% Modulated with 1kHz
3. Scanning Frequency	80MHz - 1000MHz
4. Dwell Time	3 Seconds
5. Frequency step size Δf :	1%
6. The rate of Swept of Frequency	1.5×10^{-3} decades/s

7.5. Deviation from Test Standard

No deviation.

7.6. Test Result

Product	Network Camera		
Test Item	Radiated susceptibility		
Test Mode	Mode 1: FE9382-EHV, DC		
Date of Test	2016/08/26	Test Site	Chamber5

Frequency (MHz)	Position (Angle)	Polarity (H or V)	Field Strength (V/m)	Required Criteria	Complied To Criteria (A,B,C)	Results
80-1000	0°	H	3	A	A	PASS
80-1000	0°	V	3	A	A	PASS
80-1000	90°	H	3	A	A	PASS
80-1000	90°	V	3	A	A	PASS
80-1000	180°	H	3	A	A	PASS
80-1000	180°	V	3	A	A	PASS
80-1000	270°	H	3	A	A	PASS
80-1000	270°	V	3	A	A	PASS

Note:

The testing performed is from lowest level up to the highest level as required by standard, but only highest level is shown on the report.

- Meet criteria A: Operate as intended during and after the test
- Meet criteria B: Operate as intended after the test
- Meet criteria C: Loss/Error of function
- Additional Information
 - There was no observable degradation in performance.
 - EUT stopped operation and could / could not be reset by operator at _____ V/m at frequency _____MHz.
- No false alarms or other malfunctions were observed during or after the test.

Product	Network Camera		
Test Item	Radiated susceptibility		
Test Mode	Mode 2: FE9382-EHV, PoE		
Date of Test	2016/08/26	Test Site	Chamber5

Frequency (MHz)	Position (Angle)	Polarity (H or V)	Field Strength (V/m)	Required Criteria	Complied To Criteria (A,B,C)	Results
80-1000	0°	H	3	A	A	PASS
80-1000	0°	V	3	A	A	PASS
80-1000	90°	H	3	A	A	PASS
80-1000	90°	V	3	A	A	PASS
80-1000	180°	H	3	A	A	PASS
80-1000	180°	V	3	A	A	PASS
80-1000	270°	H	3	A	A	PASS
80-1000	270°	V	3	A	A	PASS

Note:

The testing performed is from lowest level up to the highest level as required by standard, but only highest level is shown on the report.

- Meet criteria A: Operate as intended during and after the test
- Meet criteria B: Operate as intended after the test
- Meet criteria C: Loss/Error of function
- Additional Information
 - There was no observable degradation in performance.
 - EUT stopped operation and could / could not be reset by operator at _____ V/m at frequency _____MHz.
- No false alarms or other malfunctions were observed during or after the test.

7.7. Test Photograph

Test Mode : Mode 1: FE9382-EHV, DC

Description : Radiated Susceptibility Test Setup



Test Mode : Mode 1: FE9382-EHV, DC

Description : Radiated Susceptibility Test Setup



Test Mode : Mode 1: FE9382-EHV, DC
Description : Radiated Susceptibility Test Setup



Test Mode : Mode 1: FE9382-EHV, DC
Description : Radiated Susceptibility Test Setup



Test Mode : Mode 1: FE9382-EHV, DC
Description : Radiated Susceptibility Test Setup



Test Mode : Mode 1: FE9382-EHV, DC
Description : Radiated Susceptibility Test Setup



Test Mode : Mode 2: FE9382-EHV, PoE
Description : Radiated Susceptibility Test Setup



Test Mode : Mode 2: FE9382-EHV, PoE
Description : Radiated Susceptibility Test Setup



Test Mode : Mode 2: FE9382-EHV, PoE
Description : Radiated Susceptibility Test Setup



Test Mode : Mode 2: FE9382-EHV, PoE
Description : Radiated Susceptibility Test Setup



Test Mode : Mode 2: FE9382-EHV, PoE
Description : Radiated Susceptibility Test Setup



Test Mode : Mode 2: FE9382-EHV, PoE
Description : Radiated Susceptibility Test Setup

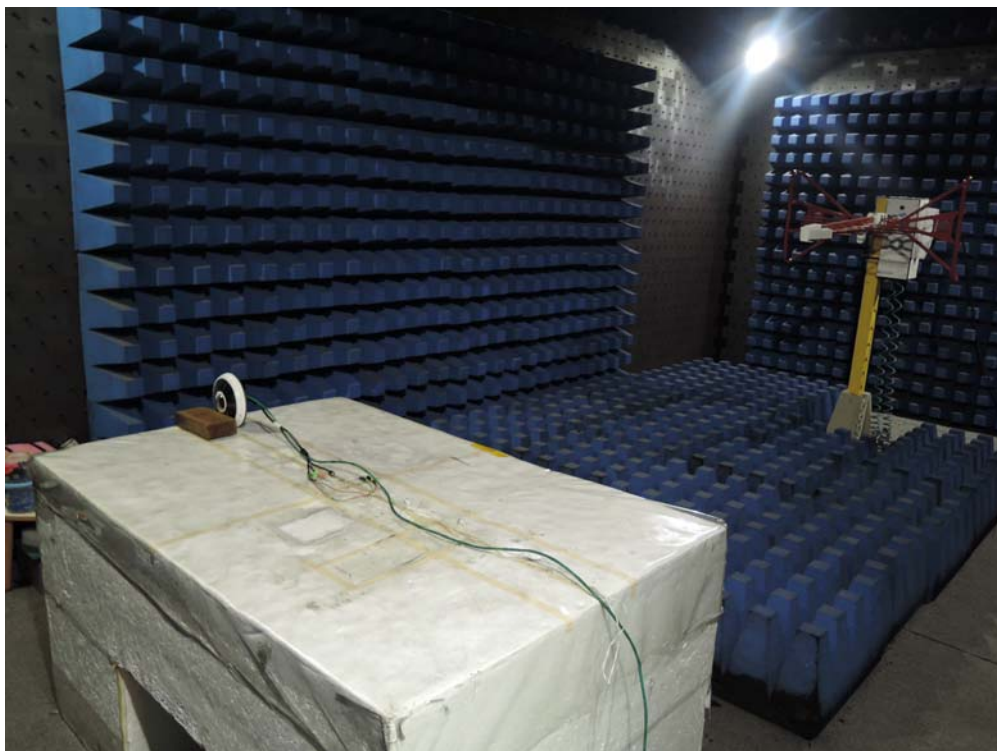

8. Electrical Fast Transient/Burst

8.1. Test Specification

According to Standard : IEC 61000-4-4

8.2. Test Setup

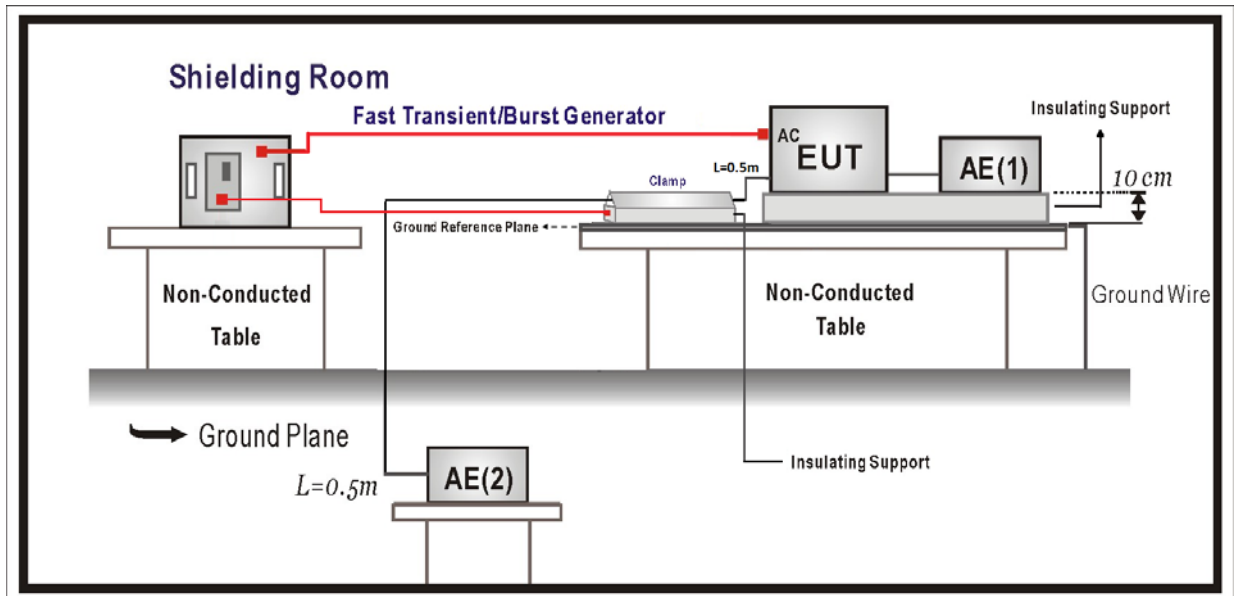

8.3. Limit

Item	Environmental Phenomena	Units	Test Specification	Performance Criteria
I/O and communication ports				
	Fast Transients Common Mode	kV (Peak) Tr/Th ns Rep. Frequency kHz	± 0.5 5/50 5	B
Input DC Power Ports				
	Fast Transients Common Mode	kV (Peak) Tr/Th ns Rep. Frequency kHz	± 0.5 5/50 5	B
Input AC Power Ports				
	Fast Transients Common Mode	kV (Peak) Tr/Th ns Rep. Frequency kHz	± 1 5/50 5	B

8.4. Test Procedure

The EUT is placed on a table that is 0.8 meter height. A ground reference plane is placed on the table, and uses a 0.1m insulation between the EUT and ground reference plane.

The minimum area of the ground reference plane is 1m*1m, and 0.65mm thick min, and projected beyond the EUT by at least 0.1m on all sides.

Test on I/O and communication ports:

The EFT interference signal is through a coupling clamp device couples to the signal and control lines of the EUT with burst noise for 1 minute.

Test on power supply ports:

The EUT is connected to the power mains through a coupling device that directly couples the EFT/B interference signal.

Each of the Line and Neutral conductors is impressed with burst noise for 1 minute.

The length of the signal and power lines between the coupling device and the EUT is 0.5m.

8.5. Deviation from Test Standard

No deviation.

8.6. Test Result

Product	Network Camera		
Test Item	Electrical fast transient/burst		
Test Mode	Mode 1: FE9382-EHV, DC		
Date of Test	2016/08/30	Test Site	No.6 Shielded Room

Inject Line	Polarity	Voltage kV	Inject Time (Second)	Inject Method	Required Criteria	Complied to Criteria	Result
L	±	0.5kV	60	Direct	B	A	PASS
N	±	0.5kV	60	Direct	B	A	PASS
L-N	±	0.5kV	60	Direct	B	A	PASS
LAN	±	0.5kV	60	Clamp	B	A	PASS

Note:

The testing performed is from lowest level up to the highest level as required by standard, but only highest level is shown on the report.

- Meet criteria A : Operate as intended during and after the test
- Meet criteria B : Operate as intended after the test
- Meet criteria C : Loss/Error of function
- Additional Information
 - EUT stopped operation and could / could not be reset by operator at _____ kV of Line _____.
- No false alarms or other malfunctions were observed during or after the test.

Product	Network Camera		
Test Item	Electrical fast transient/burst		
Test Mode	Mode 2: FE9382-EHV, PoE		
Date of Test	2016/08/30	Test Site	No.6 Shielded Room

Inject Line	Polarity	Voltage kV	Inject Time (Second)	Inject Method	Required Criteria	Complied to Criteria	Result
LAN	±	0.5kV	60	Clamp	B	A	PASS

Note:

The testing performed is from lowest level up to the highest level as required by standard, but only highest level is shown on the report.

- Meet criteria A : Operate as intended during and after the test
- Meet criteria B : Operate as intended after the test
- Meet criteria C : Loss/Error of function
- Additional Information
 - EUT stopped operation and could / could not be reset by operator at _____ kV of Line _____.
- No false alarms or other malfunctions were observed during or after the test.

8.7. Test Photograph

Test Mode : Mode 1: FE9382-EHV, DC

Description : EFT/B Test Setup



Test Mode : Mode 1: FE9382-EHV, DC

Description : EFT/B Test Setup-Clamp



Test Mode : Mode 2: FE9382-EHV, PoE

Description : EFT/B Test Setup-Clamp



9. Surge

9.1. Test Specification

According to Standard : IEC 61000-4-5

9.2. Test Setup

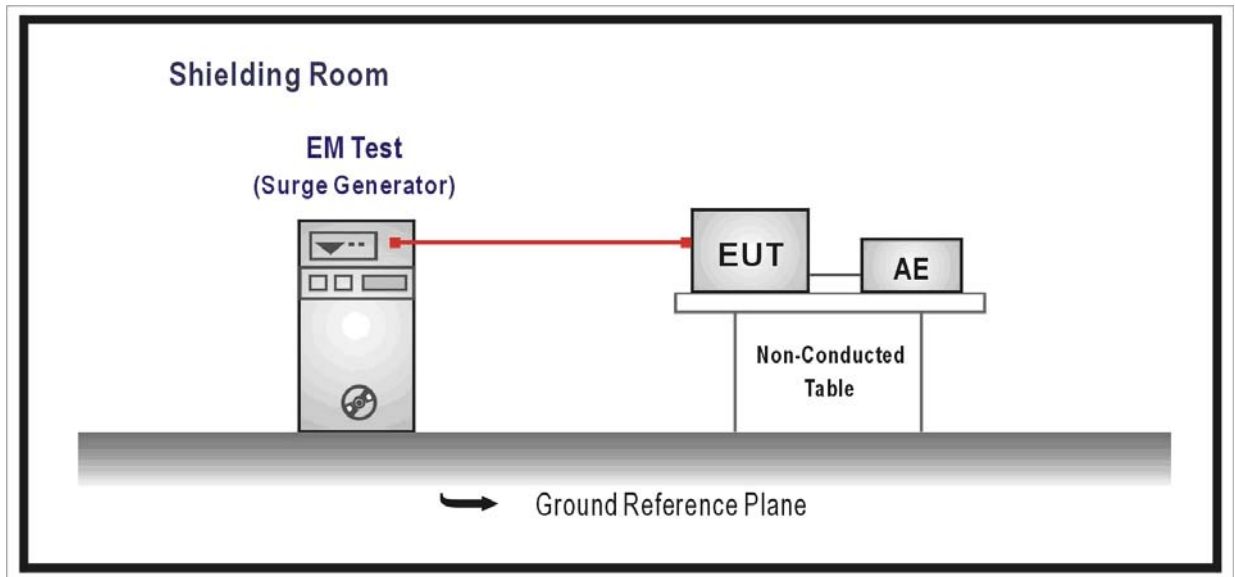

9.3. Limit

Item	Environmental Phenomena	Units	Test Specification	Performance Criteria
Signal Ports and Telecommunication Ports(See 1) and 2))				
	Surges Line to Ground	Tr/Th us kV	10/700 ± 1	C
Input DC Power Ports				
	Surges Line to Ground	Tr/Th us kV	1.2/50 (8/20) ± 0.5	B
AC Input and AC Output Power Ports				
	Surges Line to Line Line to Ground	Tr/Th us kV kV	1.2/50 (8/20) ± 1 ± 2	B

Notes:

- 1) Applicable only to ports which according to the manufacturer's specification may connect directly to outdoor cables.
- 2) Where the coupling network for the 10/700 μ s waveform affects the functioning of high speed data ports, the test shall be carried out using a 1,2/50 (8/20) μ s waveform and appropriate coupling network.

9.4. Test Procedure

The EUT and its load are placed on a table that is 0.8 meter above a metal ground plane measured 1m*1m min. and 0.65mm thick min. And projected beyond the EUT by at least 0.1m on all sides. The length of power cord between the coupling device and the EUT shall be 2m or less.

For Input and Output AC Power or DC Input and DC Output Power Ports:

The EUT is connected to the power mains through a coupling device that directly couples the Surge interference signal.

The surge noise shall be applied synchronized to the voltage phase at 0⁰, 90⁰, 180⁰, 270⁰ and the peak value of the a.c. voltage wave. (Positive and negative)

Each of Line-Earth and Line-Line is impressed with a sequence of five surge voltages with interval of 1 min.

9.5. Deviation from Test Standard

No deviation.

9.6. Test Result

Product	Network Camera		
Test Item	Surge		
Test Mode	Mode 1: FE9382-EHV, DC		
Date of Test	2016/08/30	Test Site	No.6 Shielded Room

Inject Line	Polarity	Voltage kV	Angle	Time Interval (Second)	Inject Method	Required Criteria	Complied to Criteria	Result
Line to Ground	±	0.5kV	--	60	Direct	B	A	PASS
LAN (Line to Ground)	±	1kV	--	60	Direct	B	A	PASS

Note:

The testing performed is from lowest level up to the highest level as required by standard, but only highest level is shown on the report.

- Meet criteria A : Operate as intended during and after the test
- Meet criteria B : Operate as intended after the test
- Meet criteria C : Loss/Error of function
- Additional Information
 - EUT stopped operation and could / could not be reset by operator at _____ kV of Line _____.
- No false alarms or other malfunctions were observed during or after the test.

Product	Network Camera		
Test Item	Surge		
Test Mode	Mode 2: FE9382-EHV, PoE		
Date of Test	2016/08/30	Test Site	No.6 Shielded Room

Inject Line	Polarity	Voltage kV	Angle	Time Interval (Second)	Inject Method	Required Criteria	Complied to Criteria	Result
LAN (Line to Ground)	±	1kV	--	60	Direct	B	A	PASS

Note:

The testing performed is from lowest level up to the highest level as required by standard, but only highest level is shown on the report.

- Meet criteria A : Operate as intended during and after the test
- Meet criteria B : Operate as intended after the test
- Meet criteria C : Loss/Error of function
- Additional Information
 - EUT stopped operation and could / could not be reset by operator at _____ kV of Line _____.
- No false alarms or other malfunctions were observed during or after the test.

9.7. Test Photograph

Test Mode : Mode 1: FE9382-EHV, DC

Description : SURGE Test Setup



Test Mode : Mode 1: FE9382-EHV, DC

Description : SURGE Test Setup-LAN



Test Mode : Mode 2: FE9382-EHV, PoE

Description : SURGE Test Setup-LAN



10. Conducted Susceptibility

10.1. Test Specification

According to Standard : IEC 61000-4-6

10.2. Test Setup

CDN Inject Method

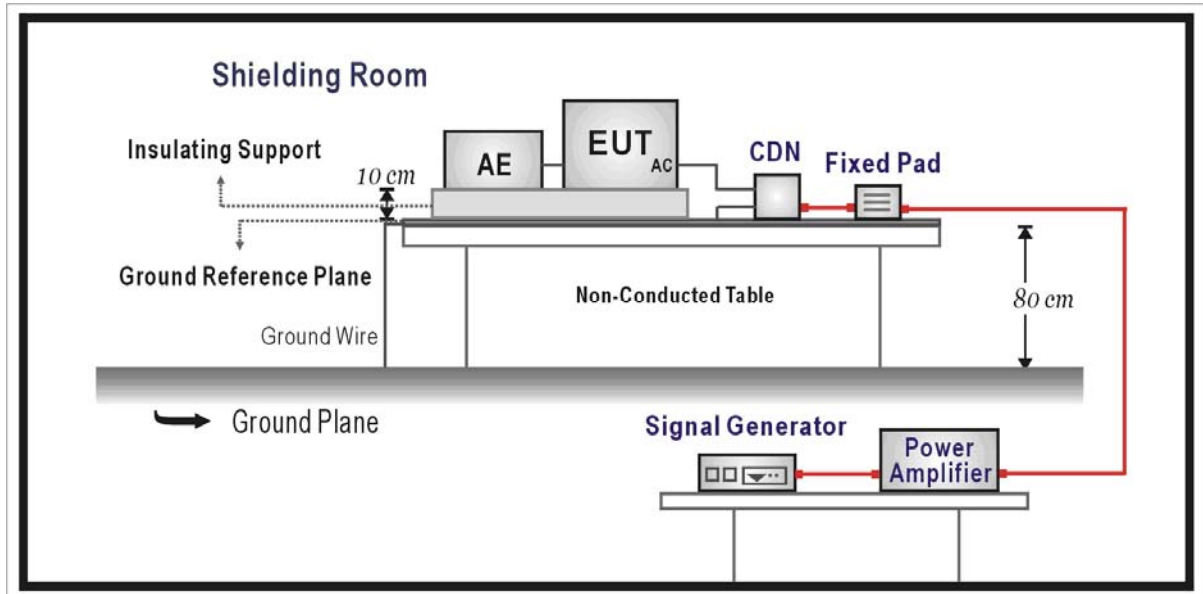

EM Clamp Inject Method

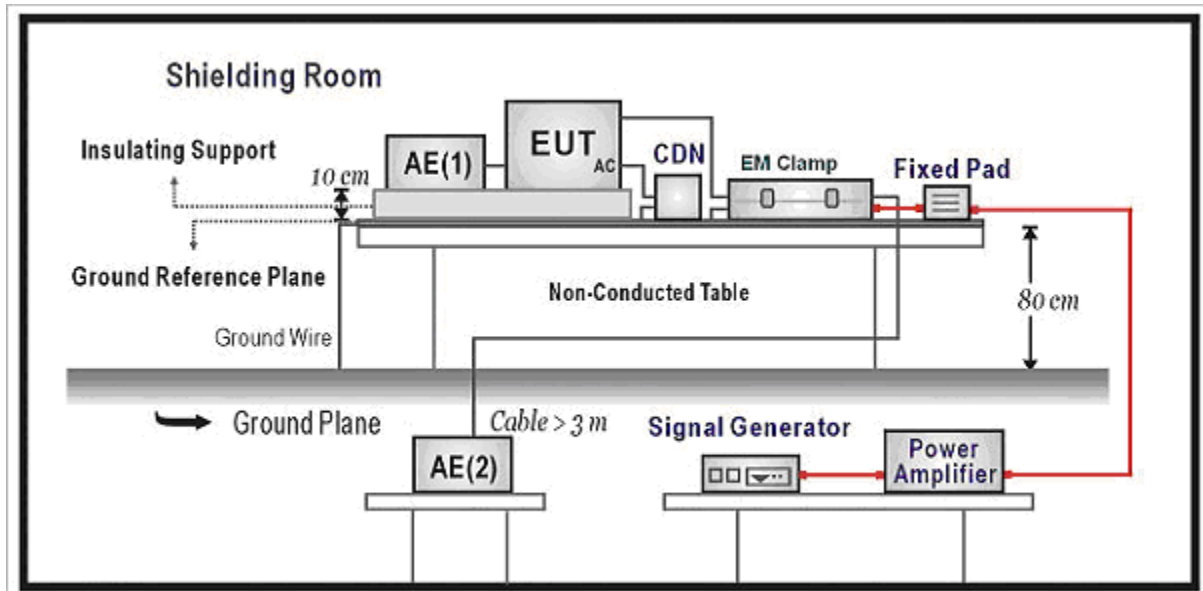

10.3. Limit

Item	Environmental Phenomena	Units	Test Specification	Performance Criteria
Signal Ports and Telecommunication Ports				
	Radio-Frequency Continuous Conducted	MHz V (rms, Un-modulated) % AM (1kHz)	0.15-80 3 80	A
Input DC Power Ports				
	Radio-Frequency Continuous Conducted	MHz V (rms, Un-modulated) % AM (1kHz)	0.15-80 3 80	A
Input AC Power Ports				
	Radio-Frequency Continuous Conducted	MHz V (rms, Un-modulated) % AM (1kHz)	0.15-80 3 80	A

10.4. Test Procedure

The EUT are placed on a table that is 0.8 meter height, and a Ground reference plane on the table, EUT are placed upon table and use a 10cm insulation between the EUT and Ground reference plane.

For Signal Ports and Telecommunication Ports

The disturbance signal is through a coupling and decoupling networks (CDN) or EM-clamp device couples to the signal and Telecommunication lines of the EUT.

For Input DC and AC Power Ports

The EUT is connected to the power mains through a coupling and decoupling networks for power supply lines. And directly couples the disturbances signal into EUT.

Used CDN-M2 for two wires or CDN-M3 for three wires.

All the scanning conditions are as follows:

Condition of Test	Remarks
1. Field Strength	130dBuV(3V) Level 2
2. Radiated Signal	AM 80% Modulated with 1kHz
3. Scanning Frequency	0.15MHz – 80MHz
4. Dwell Time	3 Seconds
5. Frequency step size Δf :	1%
6. The rate of Swept of Frequency	1.5×10^{-3} decades/s

10.5. Deviation from Test Standard

No deviation.

10.6. Test Result

Product	Network Camera		
Test Item	Conducted susceptibility		
Test Mode	Mode 1: FE9382-EHV, DC		
Date of Test	2016/08/29	Test Site	No.6 Shielded Room

Frequency Range (MHz)	Voltage Applied dBuV(V)	Inject Method	Tested Port of EUT	Required Criteria	Performance Criteria Complied To	Result
0.15~80	130 (3V)	CDN	DC IN	A	A	PASS
0.15~80	130 (3V)	CDN	LAN	A	A	PASS

Note:

The testing performed is from lowest level up to the highest level as required by standard, but only highest level is shown on the report.

- Meet criteria A : Operate as intended during and after the test
- Meet criteria B : Operate as intended after the test
- Meet criteria C : Loss/Error of function
- Additional Information
 - EUT stopped operation and could / could not be reset by operator at _____ dBuV(V) at frequency _____MHz.
 - No false alarms or other malfunctions were observed during or after the test. The acceptance criteria were met, and the EUT passed the test.

Product	Network Camera		
Test Item	Conducted susceptibility		
Test Mode	Mode 2: FE9382-EHV, PoE		
Date of Test	2016/08/29	Test Site	No.6 Shielded Room

Frequency Range (MHz)	Voltage Applied dBuV(V)	Inject Method	Tested Port of EUT	Required Criteria	Performance Criteria Complied To	Result
0.15~80	130 (3V)	CDN	LAN	A	A	PASS

Note:

The testing performed is from lowest level up to the highest level as required by standard, but only highest level is shown on the report.

- Meet criteria A : Operate as intended during and after the test
- Meet criteria B : Operate as intended after the test
- Meet criteria C : Loss/Error of function
- Additional Information
 - EUT stopped operation and could / could not be reset by operator at _____ dBuV(V) at frequency _____MHz.
 - No false alarms or other malfunctions were observed during or after the test. The acceptance criteria were met, and the EUT passed the test.

10.7. Test Photograph

Test Mode : Mode 1: FE9382-EHV, DC

Description : Conducted Susceptibility Test Setup



Test Mode : Mode 1: FE9382-EHV, DC

Description : Conducted Susceptibility Test Setup-CDN



Test Mode : Mode 2: FE9382-EHV, PoE

Description : Conducted Susceptibility Test Setup-CDN



11. Power Frequency Magnetic Field

11.1. Test Specification

According to Standard : IEC 61000-4-8

11.2. Test Setup

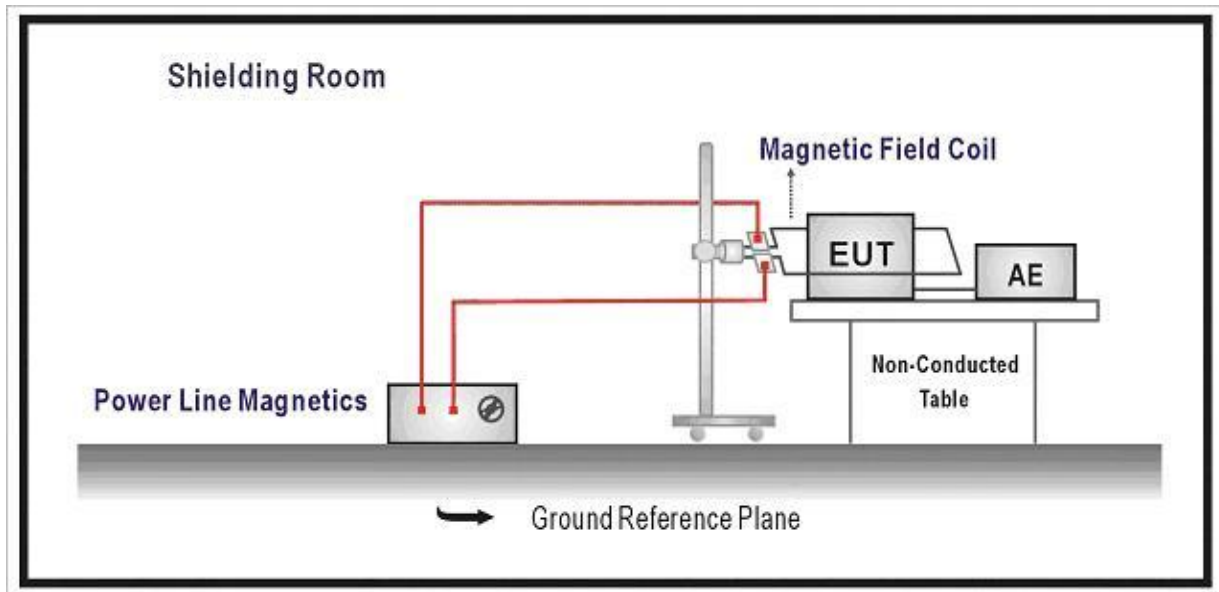

11.3. Limit

Item	Environmental Phenomena	Units	Test Specification	Performance Criteria
Enclosure Port				
	Power-Frequency Magnetic Field	Hz A/m (r.m.s.)	50 1	A

11.4. Test Procedure

The EUT and its load are placed on a table which is 0.8 meter above a metal ground plane measured at least 1m*1m min. The test magnetic field shall be placed at central of the induction coil.

The test magnetic Field shall be applied 10 minutes by the immersion method to the EUT. And the induction coil shall be rotated by 90° in order to expose the EUT to the test field with different orientation (X, Y, Z Orientations).

11.5. Deviation from Test Standard

No deviation.

11.6. Test Result

Product	Network Camera		
Test Item	Power frequency magnetic field		
Test Mode	Mode 1: FE9382-EHV, DC		
Date of Test	2016/08/26	Test Site	No.3 Shielded Room

Polarization	Frequency (Hz)	Inject Time(s)	Magnetic Strength (A/m)	Required Performance Criteria	Performance Criteria Complied To	Test Result
X Orientation	50	60	1	A	A	PASS
Y Orientation	50	60	1	A	A	PASS
Z Orientation	50	60	1	A	A	PASS

- Meet criteria A: Operate as intended during and after the test
- Meet criteria B: Operate as intended after the test
- Meet criteria C: Loss/Error of function
- Additional Information
 - EUT stopped operation and could / could not be reset by operator at _____ kV of Line _____.
- No false alarms or other malfunctions were observed during or after the test. The acceptance criteria were met, and the EUT passed the test.

Product	Network Camera		
Test Item	Power frequency magnetic field		
Test Mode	Mode 2: FE9382-EHV, PoE		
Date of Test	2016/08/26	Test Site	No.3 Shielded Room

Polarization	Frequency (Hz)	Inject Time(s)	Magnetic Strength (A/m)	Required Performance Criteria	Performance Criteria Complied To	Test Result
X Orientation	50	60	1	A	A	PASS
Y Orientation	50	60	1	A	A	PASS
Z Orientation	50	60	1	A	A	PASS

- Meet criteria A: Operate as intended during and after the test
- Meet criteria B: Operate as intended after the test
- Meet criteria C: Loss/Error of function
- Additional Information
 - EUT stopped operation and could / could not be reset by operator at _____ kV of Line _____.
- No false alarms or other malfunctions were observed during or after the test. The acceptance criteria were met, and the EUT passed the test.

11.7. Test Photograph

Test Mode : Mode 1: FE9382-EHV, DC

Description : Power Frequency Magnetic Field Test Setup

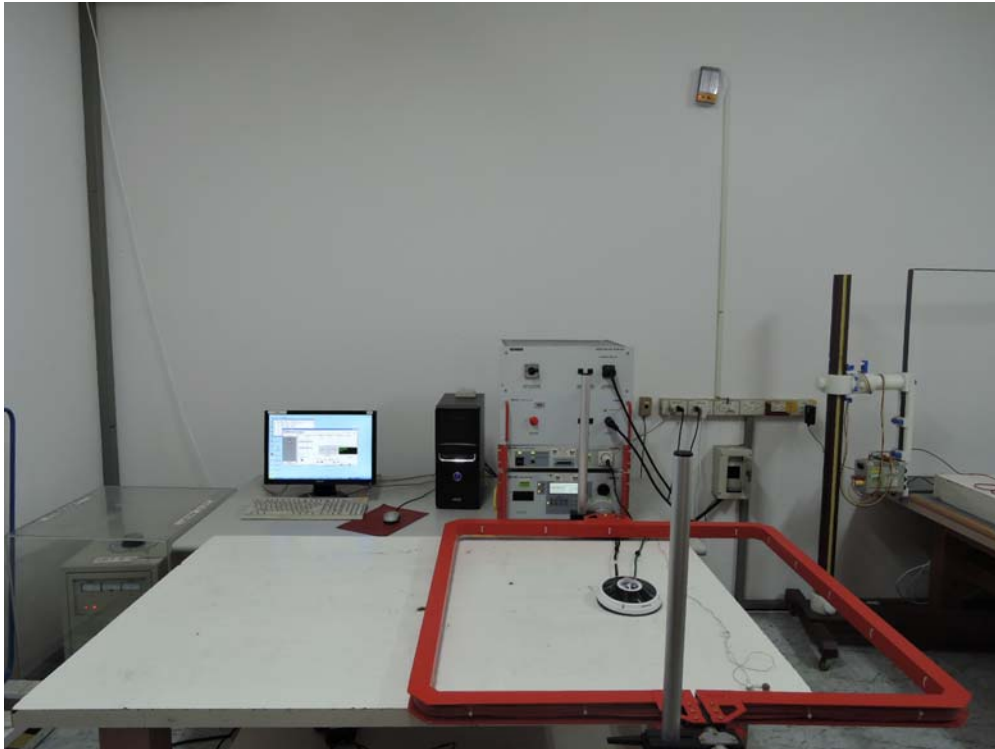

Test Mode : Mode 2: FE9382-EHV, PoE

Description : Power Frequency Magnetic Field Test Setup

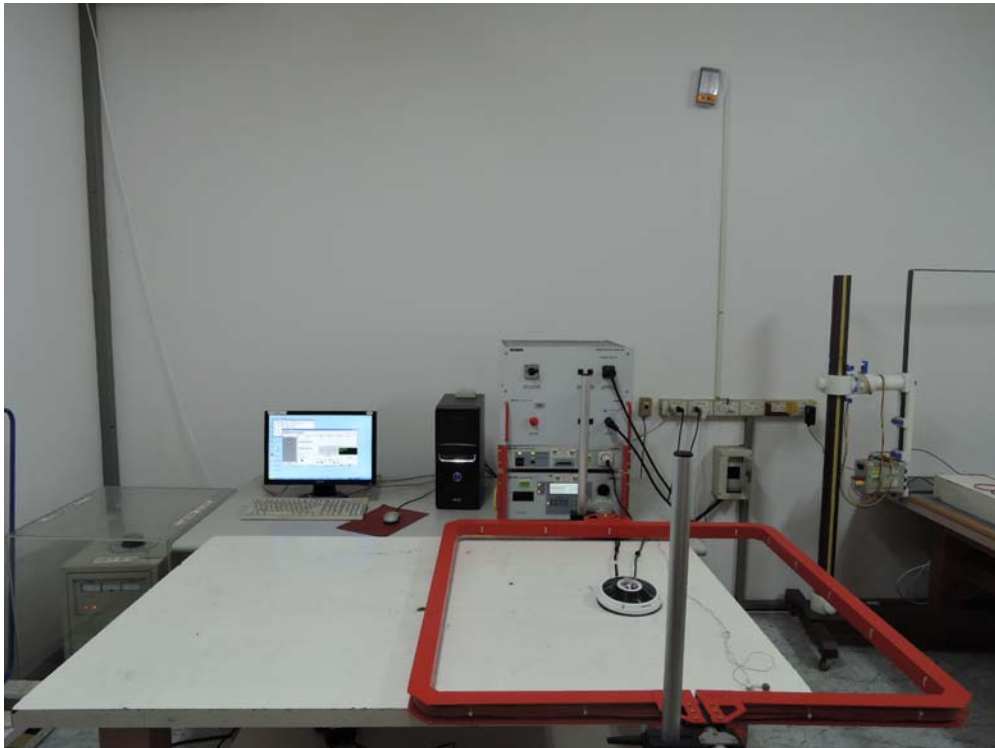

12. Attachment

➤ EUT Photograph

(1) EUT Photo



(2) EUT Photo



(3) EUT Photo



(4) EUT Photo

